

CHAPTER 4. RHEOLOGY THEORY AND EXPERIMENTAL

In the context of this thesis it is important to understand the rheology of the thermoplastic polymer, with and without the inclusion of the nanographite, in order to be able to successfully create nanographite-containing fibres.

4-1 Introduction^[1-3]

Rheology can be defined as *the science of deformation and flow of matter*, and is now recognised as an important field of scientific study. Instruments used to measure rheological properties are called rheometers. The word *Rheology* was coined by Professor Bingham of Lafayette College Indiana, and was accepted by the American Society of Rheology when it was founded in 1929.

The ability to predict and measure the rheological properties of a material is of great importance, as all materials have rheological properties. The processing of materials (injection moulding, compression moulding etc) subjects them to the laws of flow. Even during use, the materials are still subject to these laws. Considering the chemical industry, through the understanding of rheological properties, for example, in suspension polymerization, the shear rate and rheological properties of the organic phase will affect the particle size produced. Through knowledge of these properties it is possible to gain a better understanding of the best materials for use under specific process conditions, in order to achieve desired mechanical properties. In addition, the correction of faults may be easier.

It is imperative to be able to relate the molecular structure to the macroscopic rheological properties, whether considering molten plastics, suspensions or composites. Through meeting this challenge we can gain a more complete understanding of rheological properties and utilise materials better for specific applications. Information on polymer structure, most notably information on molecular weight and molecular weight distribution can be obtained from rheological measurements.

4-2 Theory^[4-8]

One of the fundamental rheological properties measured by rheometers is viscosity, which is the tendency of a liquid to resist flow as a result of internal friction. During viscous flow, mechanical energy is dissipated as heat.

In 1687 Isaac Newton published a paper where he hypothesised about a steady simple shear flow, see Figure 4-1.

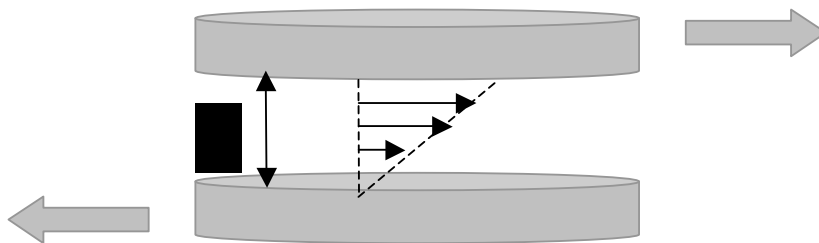

Figure 4-1– parallel plate diagram

He described two parallel plates of area, A , at 2 positions – $y = 0$ and $y = d$, with the space between them filled with a fluid which is being sheared. The upper plate moves with a relative velocity equal to U . A force, F , is required to move the top plate at this velocity. The force is directly proportional to the shear viscosity, η , of the liquid. Important quantities involved in the measurement of shear viscosity, η , are;

Shear Stress (σ)

$$\sigma = \frac{F}{A} \quad \text{Equation 4-1}$$

Shear rate ($\dot{\gamma}$);

$$\dot{\gamma} = \frac{d\gamma}{dt} = \frac{U}{D} \quad \text{Equation 4-2}$$

Shear viscosity (η) (normally referred to as viscosity);

$$\eta = \frac{\sigma}{\dot{\gamma}} \quad \text{Equation 4-3}$$

Viscosity is dependent upon shear rate, temperature, pressure and the time of shearing.

Another important consideration when defining the rheological behaviour of fluids, which must be considered, is *Newtonian* and *non-Newtonian behaviour*.

In classical mechanics the distinction between solids and liquids was assumed to be definite, with solids obeying *Hooke's Law* (1678), and liquids obeying *Newton's Law* of constant viscosity (1687). Materials which lie between these two extremes are nonetheless of significant interest. Considering a solid material; if a stress were to be exerted it would cause a deformation, which would continue until internal stresses are established to counterbalance the external stresses.

Hooke's Law states that the power of a spring is in proportion to the tension applied.

Newton's Law states that the resistance which arises as a consequence of lack of slipperiness of the liquid (where all other things are equal), is proportional to the velocity with which the parts of the liquid are separated from one another.

Most solids exhibit some degree of elastic response, where there is a complete recovery of deformation when an external stress is removed.

A Newtonian fluid is the simplest example; in this case the rate of deformation is directly proportional to the stress applied. Therefore a plot of shear stress versus shear rate is a straight line with constant slope (equal to the viscosity), which is independent of shear rate. Many fluids exhibit a non-linear response to stress, and are called non-Newtonian fluids. These materials fall somewhere between being a solid (where stress is

dependent upon instantaneous deformation) and a Newtonian fluid (where the stress depends upon the instantaneous rate of change in time of the deformation).

Many materials exhibit non-Newtonian behaviour, where a slope of shear stress versus shear rate will not be constant as the shear rate is increased. Normally the viscosity is seen to decrease as the shear rate increases, this is referred to as shear thinning behaviour. As the shear rate is increased, relaxation effects will inhibit the molecular processes responding to the applied perturbation and a lower viscosity is observed. This type of behavior is illustrated in Figure 4-2. A typical material which displays shear-thinning behaviour is molten polystyrene.

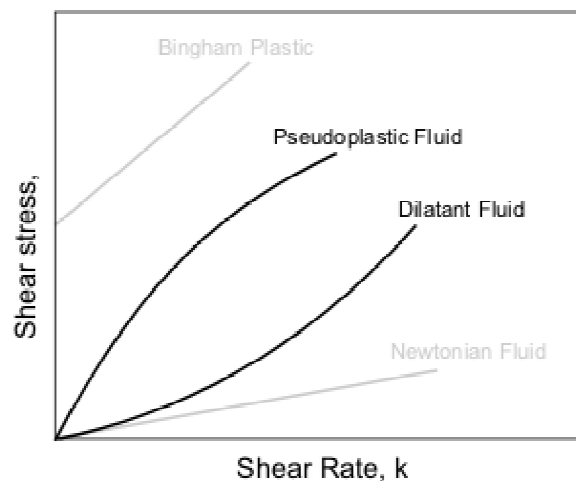

Figure 4-2 – Flow curves for many generalized Newtonian fluids

There are some instances where the viscosity increases with shear rate; such an effect is termed shear-thickening. Materials such as clay slurries behave in this way.

There are a variety of different ways in which rheological measurements can be performed; constant shear, constant strain and oscillatory shear being the most common. Which particular experiment is appropriate for a particular system depends upon the viscosity and the sensitivity to shear stress of the material.

The rheology of a fluid can be characterised by the use of a rheometer, or a rheogoniometer; although it must be stated that no one instrument can cover the full rheological spectrum. Capillary rheometers can be used to characterize non-Newtonian fluids, with high shear rates, and rotational rheometers can be fitted with several different types of geometrics depending upon the property under analysis. In this thesis the experiments pertaining to rheology are carried out on a rheometer employing parallel plate geometry.

4-3 Oscillatory Rheometry^[9,10]

Oscillatory measurements can be used to obtain data on the deformation behaviour of fluids at very low strains, and therefore on their rest structure, see Figure 4-3 for diagram of instrument

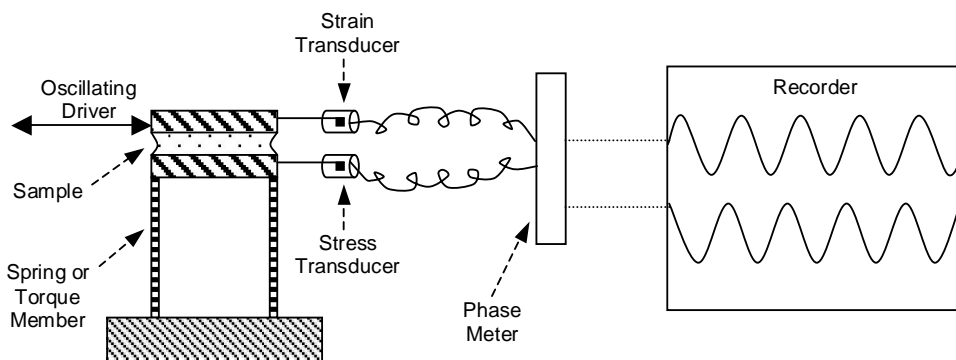

Figure 4-3 – Oscillatory Rheometer

In oscillatory rheometry a sinusoidal stress (or strain) is applied to the fluid, and the resulting sinusoidal strain (or stress) is measured.

For an elastic material an oscillating strain will have an oscillating stress response which is in phase with the strain, so δ , the phase difference between the peak value of the stress and the peak value of the strain, will be zero (as it is the strain which determines the elastic response, and this and the stress are zero at the origin). For a viscous liquid, the peak stress is out of phase by 90° . This is because the peak output stress is proportional

to the *rate of strain* (which is maximum at the origin, where the input stress is zero), see Figure 4-4.

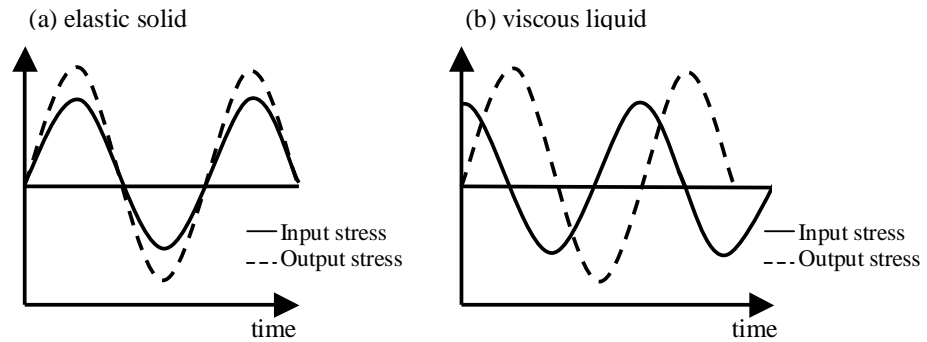

Figure 4-4 – Response Graphs

Assuming that linear viscoelasticity applies (where there exists a linear relationship between the strain and stress), the response of the target fluid under oscillation can be divided into two components – a viscous and an elastic component. The principle of the technique is to measure the phase lag and amplitudes of the input and the output signals, and use them to calculate the magnitudes of the viscous and elastic components.

Throughout, the amplitude of the deformation is assumed to be small, in order to justify the use of linear theory. There is a choice of applying either an oscillatory stress or strain, which both lead to the same information.

The elastic modulus, or storage modulus, G' , is defined as $G' = \sigma_0(\cos\delta)/\gamma_0$

where, σ = stress

γ = strain

The viscous, or loss modulus, is defined as $G'' = \sigma_0(\sin\delta)/\gamma_0$. The definitions are obtained by applying basic trigonometry to the graph in Figure 4-5.

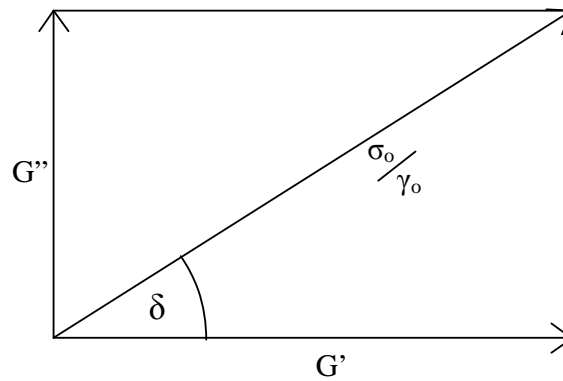

Figure 4-5 – graph from which definitions of elastic and viscous moduli are obtained^[9]

Hence, the major rheological parameters of an oscillatory flow are the viscous and elastic moduli,

$$G'(\omega) \text{ and } G''(\omega) \quad \text{Equation 4-4}$$

where ω = frequency

One has to introduce some more terms and equations in order to fully explain oscillatory rheometry. η' – the dynamic viscosity – which is equal to G''/ω . It is also necessary to introduce the complex viscosity, η^* , the size of which is given by,

$$|\eta^*| = \sqrt{\eta'^2 + \left(\frac{G'}{\omega}\right)^2} \quad \text{Equation 4-5}$$

Typical spectra for the viscous and elastic moduli, $G'(\omega)$ and $G''(\omega)$, for a typical polymer over a range of frequencies is shown in Figure 4-6. The values obtained for a particular polymer depend ultimately upon exactly where on the graph the measurement is being taken.

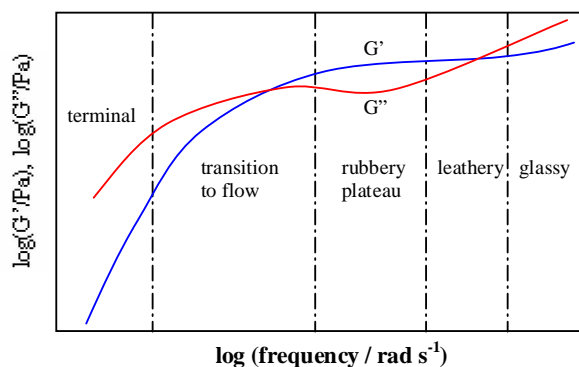

Figure 4-6 – Regions of spectra

Dynamic oscillatory experiments give rise to different information to that which is obtained from equilibrium steady state experiments. The fact that they are performed in the linear viscoelasticity region means that small deformations give rise to dynamic viscosities and moduli, which are functions of the fluid in its rest state.

4-4 Experimental

4-4-1 Polymerisation of PES-Based Co-Polymer (reaction carried out by Cytec)

The thermoplastic polymer which was primarily utilised in these studies was a commercial poly(ethersulfone) PES/PEES-based co-polymer (supplied by Cytec Engineered Materials). Details of the synthesis are proprietary but may be summarised according to the reaction schemes detailed in Section 4-4-2 and 4-4-3:

4-4-2 Formation of PEES Unit

Hydroquinone, or benzene-1,4-diol, reacts with potassium carbonate to generate O⁻ groups, which undergo a nucleophilic substitution reaction with the DCDPS to generate a PEES (polyether ether sulfone) unit.

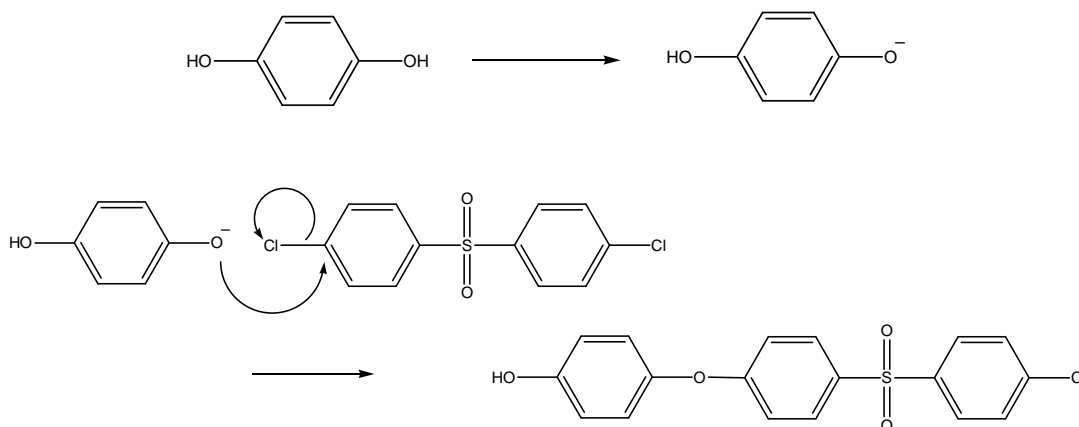

Figure 4-7 – Reaction mechanism for formation of PEES unit

4-4-3 Formation of PES Unit

Bisphenol S reacts with potassium carbonate to generate O^- groups; these undergo a nucleophilic substitution reaction with the DCDPS to generate a PES unit.

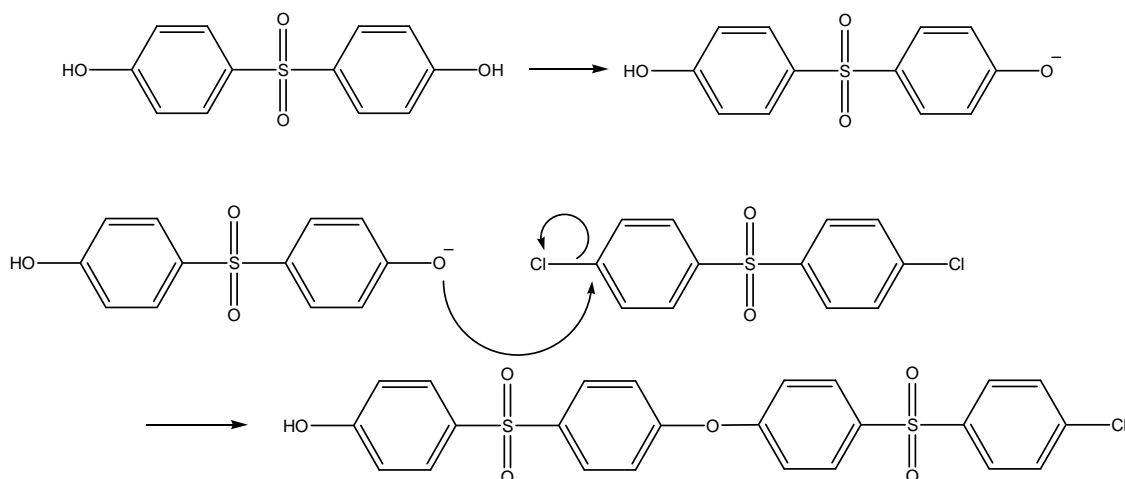

Figure 4-8 – Reaction mechanism for the formation of PES unit

The polymer builds up through these two reactions to form the copolymer shown in Figure 4-9.

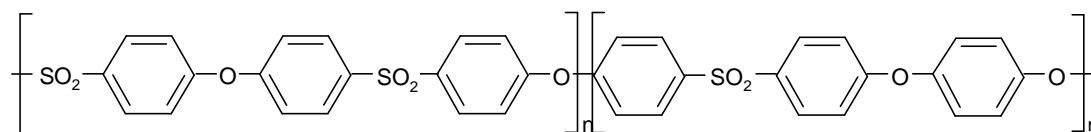

Figure 4-9 – PES/PEES copolymer

4-4-4 Radel A-100

As discussed previously the main polymer utilised in this project was a PES-based co-polymer. In addition, another commercial PES-based co-polymer, with the trade name Radel A-100, was utilised for comparison studies. The principal difference between the two materials is that the PES-based co-polymer is terminated by amine and hydroxyl while the Radel A-100 is solely chlorine terminated. The structure of the Radel A-100 PES was not disclosed by the manufacturer, but is thought to be very similar to that shown in Figure 4-9. Additionally, directly blended 10 % nanographite/ PES-based co-polymer powder samples were also utilised in this study. The discussion relating to the nanographite used in this thesis can be found in the materials section at the start of Chapter 2.

4-4-5 Rheology

The instrument used was a CSL² 500 Carri-Med rheometer. It has the capacity to heat materials from room temperature through to 400°C. A two centimetre parallel plate was used in the experiments. The compressed air (the rheometer requires a working pressure of 2 bar) and water supply were first of all switched on and the rheology program loaded. The temperature was set to 260°C, which is the mid-point of the temperatures employed and the gap was set to 250 μm. The ram was then raised and the instrument left until the set temperature was achieved. The gap was then set to zero to account for any change in the position of the plate, and the ram was again lowered. Approximately 0.1 g of sample was then placed in the centre of the plate and the ram was raised again. Once the set temperature was reached, the rheology program, Navigator, was loaded.

The software was programmed to run at five temperatures, 280, 270, 260, 250 and 240°C, and to sweep through a frequency range of 0.1-100 rad.s⁻¹. In the project, lower frequencies were also utilised by altering the program. Once the program had finished, the strain (which should remain constant throughout, on this particular instrument), stress, G', G'' and η^* values were then copied onto a floppy disc and the required graphs plotted in Excel.

All experiments were conducted in the presence of nitrogen to preclude oxidative degradation of the sample. Temperature control was satisfactory to within $\pm 1^\circ\text{C}$.

4-5 References

1. E.T. Savers, *Rheology of Polymers*. 1962, Reinhold Pub Corp, New York.
2. J.W. Goodwin, R.W. Hughes, *Rheology for Chemists: An Introduction*. 2008, RSC Publishing.
3. H.A. Barnes, J.F. Hutton, K. Walters, *An Introduction to Rheology*. 1989, Elsevier.
4. C.W. Makosko, *Rheology: Principles. Measurements and Applications*. 1994, John Wiley and Sons.
5. J. Kahovec, *Rheology of Polymer Systems*. 2001, Wiley
6. L.E. Nielsen, *Polymer Rheology*. 1977, Marcel Dekker
7. J.F. Agassant, P. Avenas, J.P. Sergent, P.J. Carreau, *Polymer Processing: Principles and Modelling*. 1991, Hanser Gardner.
8. D.G. Baird, D.I. Collias, *Polymer Processing Principles and Design*. 1998, Wiley.
9. N. Hudson, *Process Rheology Postgraduate Course Notes*, 2006
10. A.G. Fredrickson, *Principles and Applications of Rheology*. 1964, Prentice Hall.