

**Low Income Housing In Abu Dhabi
The United Arab Emirates**

Khaled H. Sedky, BSc. Architecture

**A Thesis Submitted
for the degree of Doctor of Philosophy**

**Urban Design Studies Unit
Department of Architecture and Building Science
University of Strathclyde, Glasgow
November 1994**



IMAGING SERVICES NORTH

Boston Spa, Wetherby

West Yorkshire, LS23 7BQ

www.bl.uk

BEST COPY AVAILABLE.

VARIABLE PRINT QUALITY

**ORIGINAL COPY TIGHTLY
BOUND**

To ... The United Arab Emirates

I dedicate this research work to the United Arab Emirates, and to all who would like to continue building the dam of prosperity in the fields of housing and urban design. To all my compatriots, I offer this foundation stone with all my best wishes of success.

Khaled H Sedky

10 April 1994

The copyright of this thesis belongs to the author under the terms of the United Kingdom Copyright Acts as qualified by the University of Starthclyde Regulation 3.49. Due acknowledgement must always be made of the use of any material contained in, or derived from, this thesis.

Low Income Housing In Abu Dhabi

Ph D Research

<u>Research contents</u>	I-II
* Acknowledgements	III
** Abstract	IV
*** Introduction	V-VIII
Chapter One : Conditions influencing housing in Abu Dhabi	1-29
1.1 Site conditions	
1.2 Historical conditions	
1.3 Ecological conditions	
1.4 Climatological conditions	
1.5 Socio-cultural background of the local people	
1.6 Economy and Housing policy in Abu Dhabi	
Chapter Two : Housing types & Methods of construction in Abu Dhabi	30-142
2.1 Analysis of the (social, environmental, etc. ...) feasibility of the houses built before the discovery of oil & conclusion	
2.2 Analysis of the (social, environmental, etc. ...) feasibility of the houses built after the discovery of oil & conclusion	
2.3 Post-occupancy housing survey carried out by the Planning Department of Abu Dhabi	
2.4 Conclusion	
Chapter Three : Neighbourhood patterns in Abu Dhabi	143-156
3.1 Examples for traditional neighbourhood patterns	
3.2 Examples for contemporary neighbourhood patterns	
3.3 Conclusion	
Chapter Four : Establishing the criteria of housing design in Abu Dhabi	157-169
4.1 Developing dwelling unit standards	
4.2 Developing layout parameters for groups of houses	

Chapter Five : Developing, evaluating and selecting dwelling unit layouts and groups of houses	170-213
5.1 The dwelling unit design solutions; Types I & II	
5.2 The mini-neighbourhood proposed design solution	
Chapter Six : Summary and recommendations for further research	214-218
The summary of the research work already carried out, and recommendations for further research to be carried out with the aim of originating civilisational values in buiulding the islamic cities in general and neighbourhoods in particular.	
Bibliography	219-226

A c k n o w l e d g e m e n t s

The author acknowledges a deep and enormous debt to Dr. Hildebrand W Frey for his constant and continuous supervision. His precision, understanding and concern were indispensable during the course of this research. Without perception nor preaching he was always rational in his advice, analytical in his critique, methodical in his approach and encyclopedical in his debate; on which progress in this research work has depended a lot.

Fully heartfelt recognisance of my family's and my wife's understanding of my absence when it was a must, belief in my research work, and the complete support and devotion they offered me to bring this work into reality.

The author is grateful to Dr. Abdel Rahman Makhlof, Professor Miles Danby, and Dr. Hassan Wahby for helping me define the exact aim of this research, enhance my research proposition, and guide me during my research part-time period respectively.

Most of all my thanks are due to Mr. Abdul Redah Abu El Hassan - BSc Arch., Mr. Zakarya El Nimr - BSc Eng., and Mr. Awsam Matloob- MSc Arch., for their spontaneous efforts in providing essential, precious, and important information without which this research work would have been incomplete. The author thanks Mr. Mark Currid for editing this research work.

Last but not least, I would like to thank sincerely all my colleagues for their help offers and support.

A b s t r a c t

The provision of houses for the tribal society in the Emirate of Abu Dhabi constitutes a major problem which greatly aggravates the housing problem in general.

The major cause of this problem is that the designers of housing schemes have no sufficient understanding of the tribal traditions and requirements, necessary to provide the local people with convenient dwelling units that correspond with their social behaviour pattern.

Ever since oil was discovered in Abu Dhabi, the government has developed an ambitious housing policy to serve the provision of local people with houses.

The policy has been carried out for the last 25 years, where the government decided to :-

1. design convenient dwelling units for the local people;
2. plan new neighbourhoods and supply them with a sufficient infrastructure;
3. construct the dwelling units and maintain them once the local people have become their legal owners.

The objectives of this policy were to provide the proper environment for the local people. There has been a great change in the design of housing schemes ever since this policy started. A number of foreign architects were involved in the development of a variety of low cost housing types, and inevitably their different cultural backgrounds influenced the design solutions. Many of their schemes use layouts and construction systems which contradict local behaviour patterns and climatic conditions.

During this period of 25 years Abu Dhabi has developed extensive experience in the field of housing but it is not always positive. This experience is worth registering, analysing and evaluating.

I n t r o d u c t i o n

Since the discovery of oil the government of Abu Dhabi has developed the localisation policy of its inhabitants, an intensive need of housing provision rose. The local inhabitants had to give up their old traditional houses for low income houses that the government offers them. Governmental authorities are charged to design, build and maintain convenient dwelling units for the local people. The government of Abu Dhabi simultaneously encourages the local people to increase their birth rate. Taking into consideration the lack of knowledge of foreign architects and designers in charge of this policy concerning the local inhabitants, and the absence of practical design methods and criteria based on actual local facts and constructive research work. The high rate of growth of the local people resulted in the growing need of low income houses which resulted in the acceleration of the building process. Thus led to mass construction with no time to study, analyse and feed back. Here rises the problem, an ambitious policy with sincere intentions and inconvenient results. The low income housing problem in Abu Dhabi has several dimensions, which are:

Socio-cultural

Housing designers do not take into consideration the family rate of growth, thus the dwelling unit future expansion.

Most of the low income houses are of small sizes, two bedroom houses, which do not suit local families who's average size is five persons per family (1).

The low income housing designs are not convenient for households' way of living (1), where three families (17 persons) have to live together in a two bedroom house where privacy is completely neglected by the designer (2).

Functional

The location of different spaces in the house in relation to each other does not cope with the every-day-life activities of the households.

The house different rooms are not spacious enough to accommodate the households daily activities (1).

Technical

The houses are not sound enough, where in some cases the house roof cracked and fell down on the floor all of a sudden (3). Roofs were not constructed to bear live loads eventhough being accessible, where the households had to block the stair ways with tree branches to prevent children from climbing the stairs (4). The lack of maintainence and non surveyed building contractors are most of the time the reasons behind technical problems.

Climatical

The houses being provided with window type air conditioning units, heat insulation and water proofing are absent, where roofs leek water as soon as it starts raining (4).

Urban

The absence of urban design resulted in the construction of randomly assembled and scatterly layed out housing clusters in remote areas where the lack of infrastructure obliged the households to give up their homes (1).

Due to the importance of the low income housing problem in Abu Dhabi and the urgency to help governmental authoroties and architects in charge of designing various housing types, a research in this field is a need.

The research objective

A detailed study is required to establish criteria for the design of low income housing in Abu Dhabi that would improve both the design process and the design solutions. These criteria would have to be taken into consideration before the commencement of any housing design.

The research methodology

The achievement of the research objective requires the following working stages:

1. the study of houses built in Abu Dhabi before the discovery of oil;
2. the critical analyses of available examples of low income housing types built after the discovery of oil;
3. the comparison of the results of these studies and analyses with

the results of the post-occupancy housing survey carried out by the Planning Department of Abu Dhabi, with the aim of discovering to what extent each house type has met the requirements of the local people.

As a result of these analyses, studies and comparison, a set of criteria for housing design and layout parameters of groups of houses will be established. This set of criteria will form the bases for the design of dwelling units in Abu Dhabi. A systematic design process will then be carried out to produce various dwelling unit design solutions. These dwelling units will be evaluated and unsuitable layouts will be eliminated. The remaining designs represent a collection of house types that respond to local conditions and can, therefore, be used to improve the housing situation in Abu Dhabi.

Recommendations for further research will then be made that concentrates on the layout of groups of houses in neighbourhoods, villages and towns in correspondence with traditional spatial patterns.

List of Quotations

- (1) Al'Khaleej, Newspaper, N° 3734, Monday 24, July 1989, Abu Dhabi,
p 3
- (2) ibid, N° 4244, Wednesday 19, December 1990, Abu Dhabi, p 4
- (3) ibid, N° 3740, Sunday 30, July 1989, Abu Dhabi, p 3
- (4) ibid, N° 3742, Tuesday 1, August 1989, Abu Dhabi, p 3

Chapter One

Conditions influencing housing in Abu Dhabi

In this chapter a detailed discription of the conditions influencing housing in Abu Dhabi will be carried out. These conditions are :

- 1.1 Site conditions
- 1.2 Historical conditions
- 1.3 Ecological conditions
- 1.4 Climatical conditions
- 1.5 Socio-cultural background of the local people
- 1.6 Economy and housing policy in Abu Dhabi

1 . 1 Site conditions

Abu Dhabi is one of the emirates that constitutes the United Arab Emirates. The United Arab Emirates together with its western neighbour, Qatar, and its eastern neighbour, the Sultanat of Oman, form a part of the geographical subdivision of the south easter of Arabia (1), (see Fig. 1).

The United Arab Emirates consists of seven emirates (see Fig. 2), which are :

1. Abu Dhabi
2. Dubai
3. Sharjah
4. Ra's al Khaimah
5. Fujairah
6. Umm al Qaiwain
7. Ajman

1.1.1 Location and surroundings

Abu Dhabi is by far the largest emirate, occupying approximately 87 per cent of the total U.A.E. territory (see Fig. 3). Located within latitudes 22.5 - 25 and longitudes 51 - 56 (see Fig. 2), the emirate has an area of 67,340 sq. km. (see Fig. 4) (4).

Surrounded from the north by the Gulf, Abu Dhabi has five neighbours (see Fig. 2), which are :

1. Emirate of Dubai to the north east.
2. Emirate of Sharjah to the north east.
3. Sultanat of Oman to the east.
4. Saudi Arabia to the south.
5. Qatar to the west.

The capital of Abu Dhabi, bearing the same name of the emirate, is located on an island. The island has about 16 km. of water front. Separated from the main land by a deep water channel, it is accessible by two bridges from the south cost (see Fig. 5). There are further more some two dozen islands of significance in the costal waters of the emirate, and some half a dozen sizable islands belonging to Abu Dahbi further out in the Gulf (5).

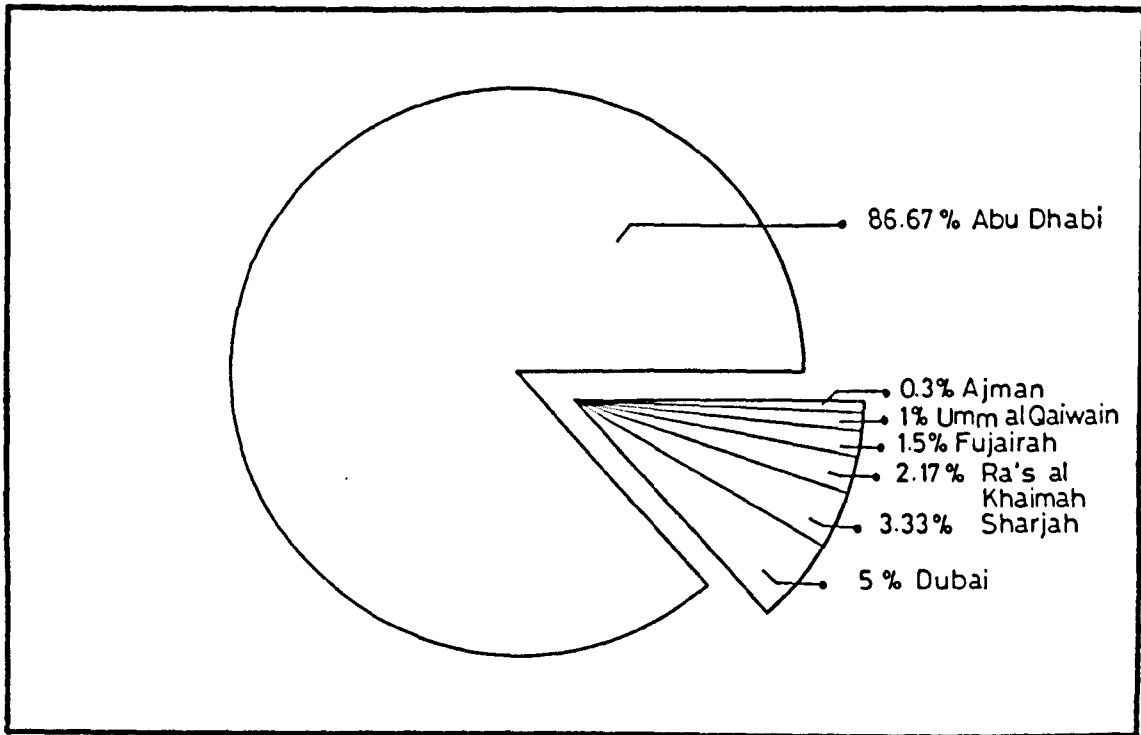

Fig. 3 : A pie chart that shows the area percentage of each emirate with respect to the whole U.A.E. area.

EMIRATE	AREA Sq.Km.	PERCENTAGE %
Abu Dhabi	67340.00	86.67
Dubai	3885.00	5.00
Sharjah	2590.00	3.33
Ra's al Khaimah	1683.50	2.17
Fujairah	1165.50	1.50
Umm al Qaiwain	777.00	1.00
Ajman	259.00	0.30
TOTAL	77,700.00	100.00

Fig. 4 : A table that shows the emirates areas and their percentages respectively.

1.1.2 Geographical features

The geographical feature that exerts a vital influence on the day-to-day life in Abu Dhabi is the desert. It forms the majority of the emirate's land. It is mostly a multitude of interlinking sand dunes (see Fig. 6), which extend from the western borders until the west side of the Hajar mountain range in the east (see Fig. 7). The extent to which the desert is habitable varies throughout Abu Dhabi's territory, depending on the availability of the fresh or brakish water.

Another geographical feature of Abu Dhabi's lands is the Sabkhah. A sabkhah is the local name of the salty mud-flats formed from dried-up lagoons. The sabkhah extends along the full length of the coast of Abu Dhabi (see Fig. 7). A sabkhah is saturated with salt and can not support any vegetation. High tide or rain turn a sabkhah, which might be passable at other times, into treacherous swamps unsafe for camel or car (5).

The Gulf faces the north part of Abu Dahbi. The whole of the Gulf is very shallow, it has a maximum depth of 50 fathoms (90 metres). The shallowness of the Gulf counts for conditions of water temperature and light which are favourable to the growth of the Pearl oysters (5). Abu Dhabi's coast is chractarised by a great number of coral reefs, sand banks and numerous low lying islands. Most of Abu Dhabi's coast is utterly flat, marsh or sandy.

Conclusion

This brief discription indicates three main predominant features of Abu Dhabi's geography : the vast area of desert reaching towards the uninhabited interior of the peninsula; the coastline which is difficult to approach both from land and sea; the sea.

These three geographical features limit the population choice for

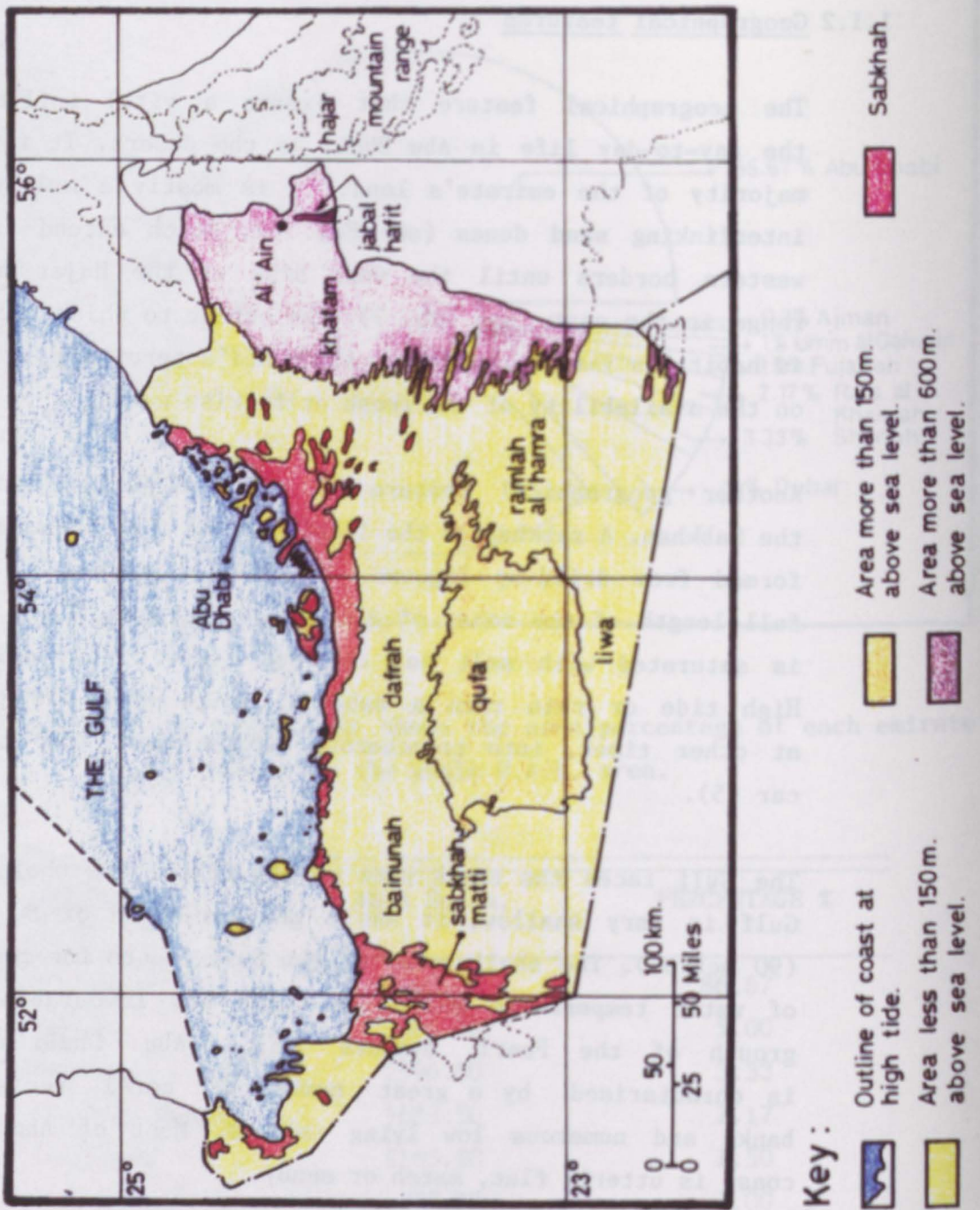

Fig. 7 : A map that shows Abu Dhabi's main geographical features (8).

establishing settlements. Thus the territory of about 67,340 sq.km. is not evenly populated, but has three sizable population centres (see Fig. 8). The majority of the emirate's 450,000 people live in the Capital on the island of Abu Dhabi, with an estimated 250,000 inhabitants. The Al'Ain area near Hafit mountain has an estimated population of 120,000 people. The Liwa oases, which have only a few permanently inhabited villages, attract a migratory population of several hundred during the hot summer months.

Due to the nature of the coastal sabkhah and the desert, communication between these three centres has been extremely difficult until recently. Abu Dhabi now is connected by a dual carriageway road 160 km. long. There is now an asphalt road to Liwa, and more roads are being constructed both across the emirate and periphery (5), (see Fig. 8).

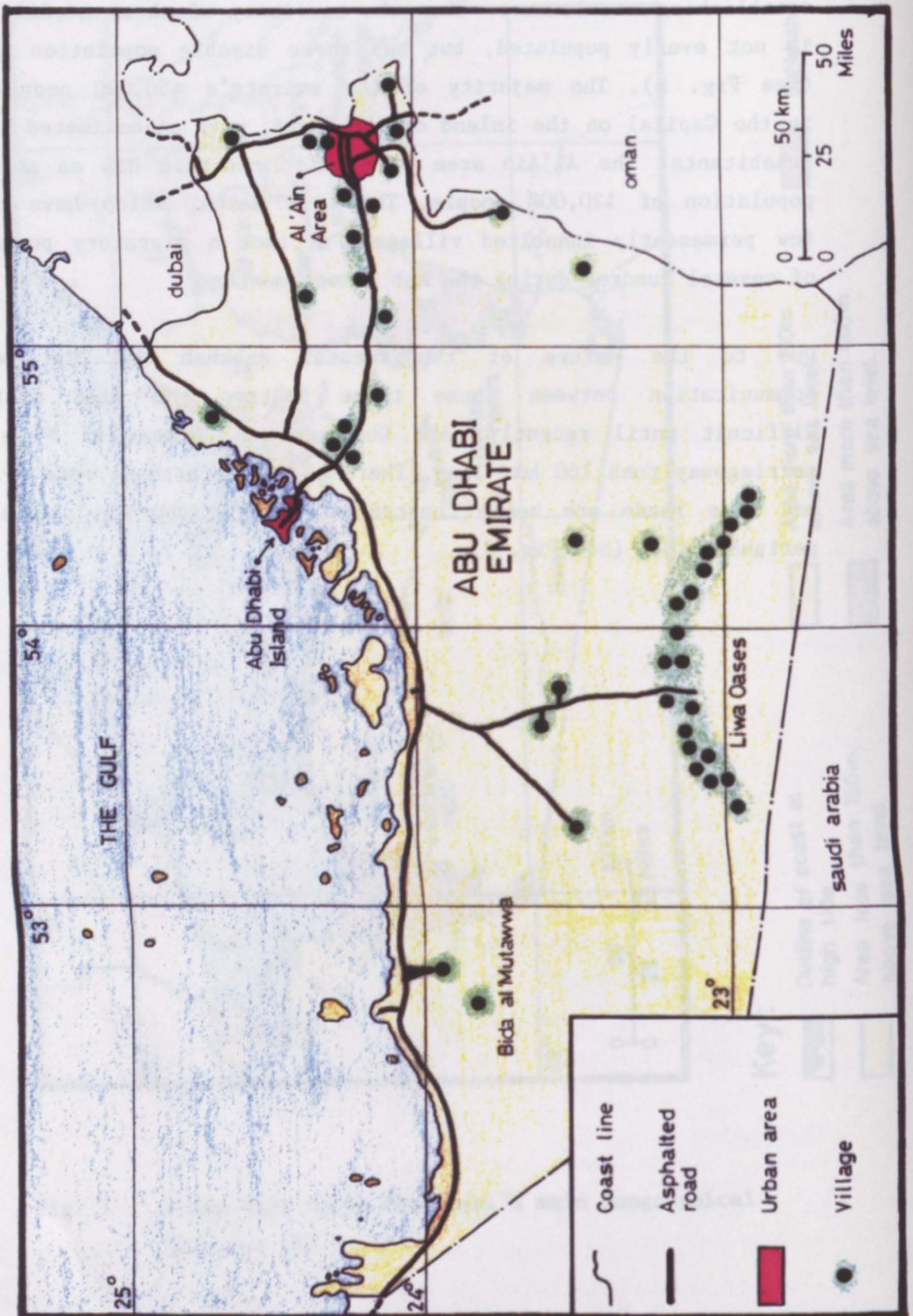

Fig. 8 : A map that shows the three main population centres of Abu Dhabi emirate (3).

1 . 2 H i s t o r i c a l c o n d i t i o n s

The recent history of Abu Dhabi demonstrates three main historical factors, which greatly influenced housing in Abu Dhabi. These three factors are :

1.2.1 Immigration of Arab merchants from the Persian coast to Dubai.

1.2.2 Discovery of oil in Abu Dhabi.

1.2.3 Abu Dhabi was one of the colonies of Great Britain.

1.2.1 Immigration of arab merchants from the Persian coast to Dubai

A large number of arab merchants were established in the Bastak district of Persia. Eventhough the greater part of Bastak is in land of Persia, it has about 55 km. of coast with a principal port called "Khamir". By the 1920's, the decline of the economic situation of the ports of southern Persia hampered the commercial activities of the arab merchants (9). Therefore, they accepted the offer of the ruler of Dubai. This offer was for them to settle down in Dubai and build themselves houses by the creek of Dubai (see Fig. 9). During this process they brought with them a new feature to the area, the wind-tower house (see Fig. 10). They are highly similar to those they inhabited in Bastak (see Fig. 11). The quarter given to the arab merchants in Dubai was given the name "al'bastakeyah". The term "al'bastakeyah" is derived from the word Bastak. This quarter became the base of influx of arab merchants who immigrated from Persia, where they introduced the wind-tower house to the neighbouring ports. Inhabitants of Abu Dhabi's coast who could afford to build more elaborate houses introduced this type of houses in Abu Dhabi. These houses were called in Abu Dhabi "biute al'sahel".

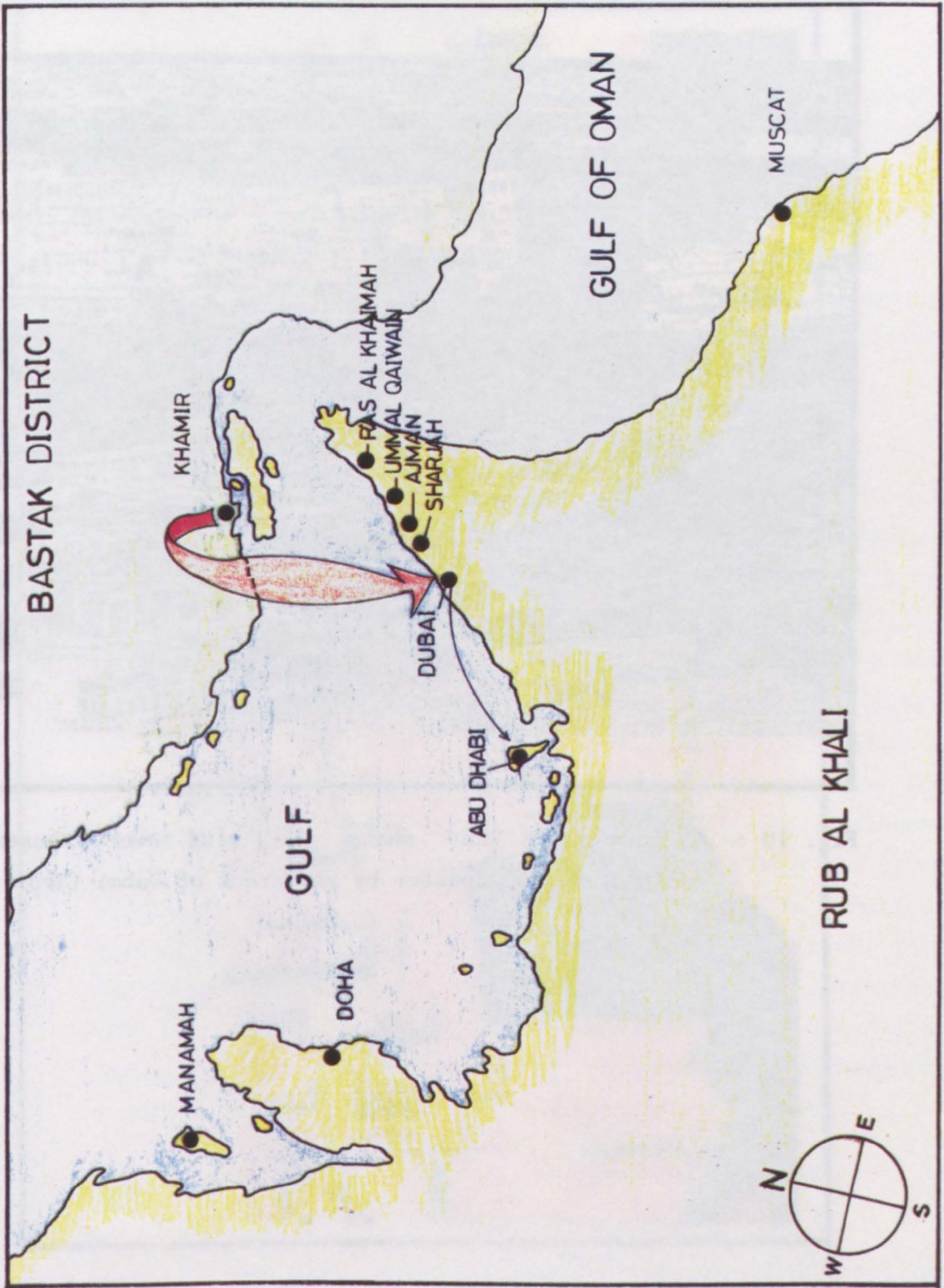

Fig. 9 : A map that shows "Khamir" in the Bastak district, from which the arab merchants emigrated to Dubai (10).

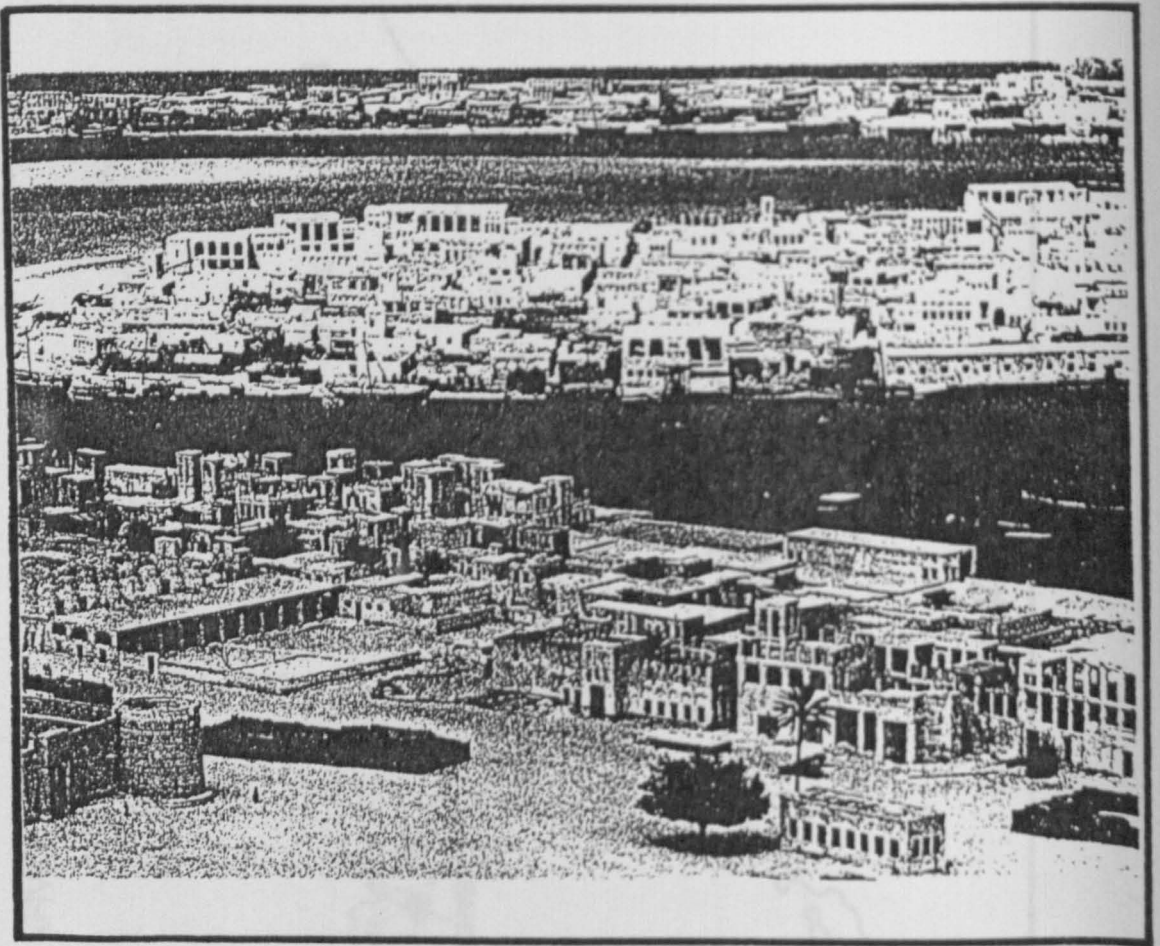

Fig. 10 : A phtograph that shows the wind-tower houses of "al'bastakeyah" quarter by the creek of Dubai (11).

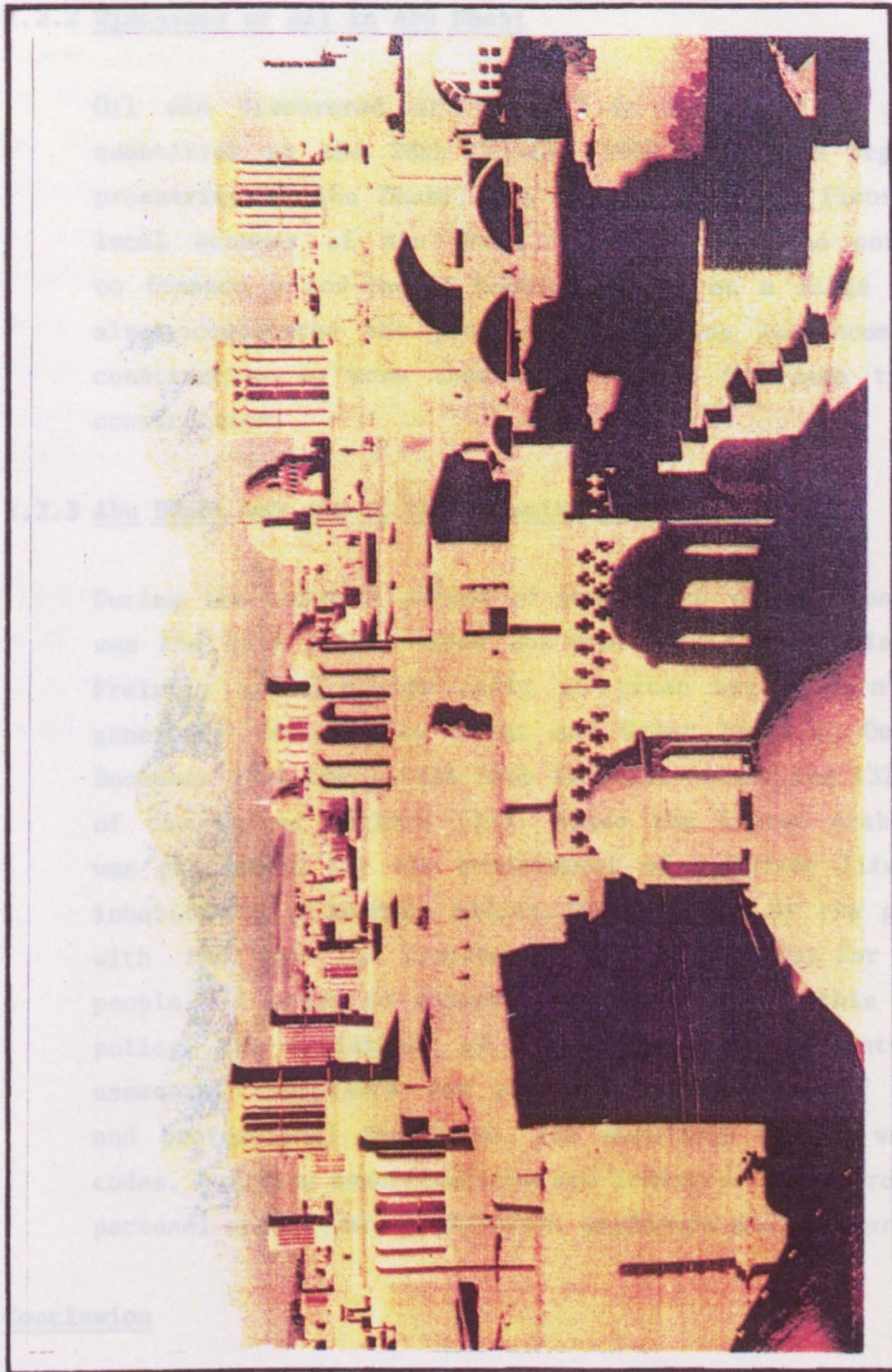

Fig. 11 : A photograph that shows the wind-tower houses in one of the cities of Persia (12).

1.2.2 Discovery of oil in Abu Dhabi

Oil was discovered at "Murban" in Abu Dhabi in commercial quantities on the 28th October 1960 (13). The beginning of prosperity in Abu Dhabi. The discovery of oil flourished the local economy of Abu Dhabi, and provided the potentiality to finance a low-income housing policy on a large scale. It also accelerated the process of building low-income houses, constructing on more than one area at the same time; mass construction.

1.2.3 Abu Dhabi was one of the colonies of Great Britain

During the colonial period of nearly 120 years, Great Britain was the only link between Abu Dhabi and the civilised world. Freindly relationships built on trust and cooperation were generated between Abu Dhabi and Great Britain. On the 9th December 1971 the United Arab Emirates became the 132nd member of the United Nations (14). Hence the United Arab Emirates was proclaimed for the achievement of a better life for its inhabitants. A housing policy, carried out by the government with the aim to provide proper environment for the local people. In order to achieve the objectives of this ambitious policy, the assistance of Great Britain was essential. This essential assistance was provided in the form of knowledge and professional personnel. The knowledge needed was design codes, building specifications and industry. Where professional personel needed were architects, engineers and builders.

Conclusion

Housing in Abu Dhabi was influenced mainly by two main civilisational currents. The first coming from Persia through Dubai before the discovery of oil. It introduced the wind-tower houses, locally called "bait al'sahel". This type of house proved through time functional efficiency and environmental adaptation. The house is built with

natural local building materials. Similar environment, society and climate helped the rapid spread of this Persian type of house in Abu Dhabi and other neighbouring areas.

The second coming from Great Britain through channels of trust, consultancy and friendship. Wherefore the assistance of Great Britain was needed to carry out an ambitious housing policy in Abu Dhabi. Different types of modern low-income houses were introduced to the local environment. Designed by foreign architects, referring to design codes based on different type of society living in a different climate. These houses are built mainly with imported building materials conforming to foreign codes. Local people complain about the inconveniency of these houses.

Moreover, various forms of foreign aid and assistance were requested in the development of the housing policy in Abu Dhabi. Thus, and inevitably other foreign civilisational backgrounds influenced the results of this policy.

1 . 3 E c o l o g i c a l c o n d i t i o n s

The severe local environment of Abu Dhabi introduces very hard living conditions. Its influence on the living creatures in the area is remarkable. A narrow range of existing natural life resources directly influences housing conditions in Abu Dhabi. This narrow range includes five main natural resources of great importance, which are :

- 1.3.1 Water resources.
- 1.3.2 Local trees.
- 1.3.3 Local domestic animals.
- 1.3.4 Coral reefs.
- 1.3.5 Oil.

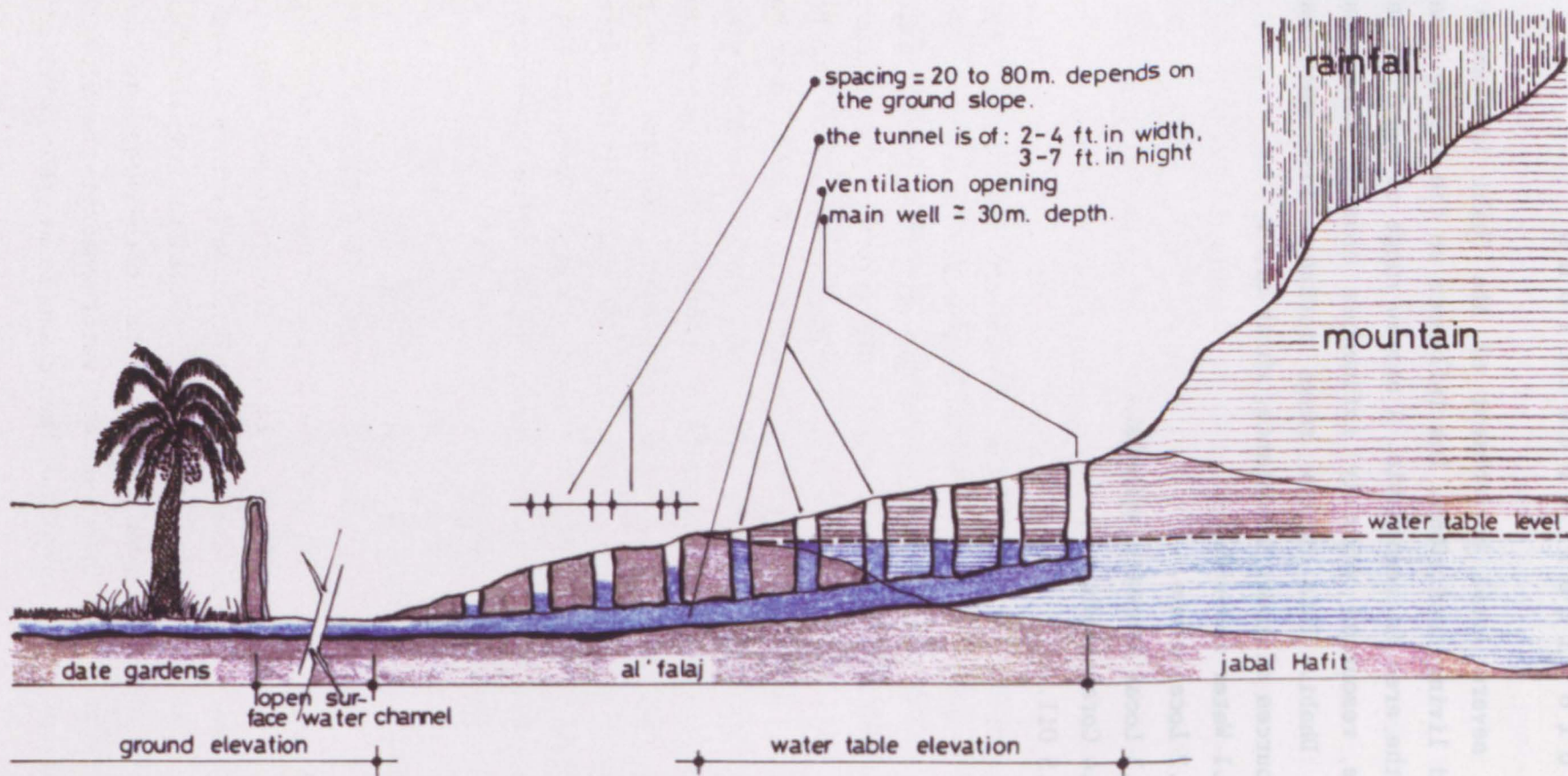

Fig. 12 : A sketch that shows a longitudinal section passing through "al-falaj" (16).

1.3.1 Water resources

Water natural resources in Abu Dhabi are of limited variety. Due to the absence of continuous main water resource such as a river or annually heavy rains, the local people depend on the underground water aquifers. Water is extracted from these aquifers by two methods, which are :

-Water wells

-Al'Aflaj

Water wells

Water wells are made by boring through strata the nature, and arrangements of which permit the permeation and accumulation of water. These wells are normally dug by hand. The underground water table in Abu Dhabi is found close to ground level by a few metres. However, it can reach sometimes to a depth of 50 - 60 metres below ground level. Water wells are of two kinds; either providing potable water or brackish water. Wells providing brackish water are found in most houses, its water is used for every day house work like cleaning, cooking and washing. Wells providing potable water are of less numbers compared with the former. They are more public rather than private, their water is used only for drinking. Water wells providing potable water can be found in Abu Dhabi island, Al'Ain area and the Liwa oases, where three main human settlements can be defined.

Al'Aflaj

The term "al'aflaj" is the plural of "al'falaj". Al'Falaj (see Fig. 12) is an age-old irrigation system, commonly used to irrigate date gardens in the several oases found in the barren sand desert of Abu Dhabi. These oases form Al'Ain area, found near the last of the Hajar mountain range called "Hafit". Al'Aflaj can irrigate more than one date garden at the same time. Through an open surface water channel the flow can be directed and regulated. The channel is then divided into

several others equal in width, where the running water of "al'falaj" reaches several date gardens. The water comes through a tunnel usually several kilometres long and originating where the elevation of the water table is higher than the elevation in the date gardens (15). "Al'Aflaj" are generally sufficient to provide a whole village with the amount of water needed for daily use. The sum of "al'aflaj" in Al'Ain area produce about 11 million gallons of water per day, sufficient for the peoples needs in the village and for irrigation (16).

1.3.2 Local plants

Local plants species, which can grow inspite of the local severe environmental conditions, are either cultivated or wild.

Cultivated

The dominating cultivated species are the date palm-trees. Plenty of date gardens are found near by permanent water resources as in Al'Ain area, Abu Dhabi and Liwa oases. The palm-trees beside providing the inhabitants with dates for consuming and trading purposes, they also form a major rich natural source of building materials. The dead tree trunks, even though very fibrous to serve for carpentary works, have always served as columns and beams in the construction of various types of local houses. The palm-tree branches, stripped of their leaves and spikes were bound together into mats. These mats form the walls and the roofs in the most common type of local houses. The leaves were used to make various household implements, such as fans, baskets, bags, food trays and their covers. The fronds were also bound together and lined with pitch to form water tanks. The fiberous bark which grows at the bottom of the tree is suitable material for weaving ropes, stuffing camel saddles, mattresses and cushions (17). It is also used as one of the main constituents forming

the houses roofs.

Wild

The local wild species are numerous. An estimated 82 different types of plants, shrubs and trees are known to the local inhabitants. Useful types are either desert or sea species.

- Desert species

Plants locally called "Al'Shenan", its latin equivalent is "Salicornia L.", are dried up and ground to form soap powder (18). Shrubs locally called "Al'Daflah", its latin equivalent is "Nerium Oleander L.", are generally used to feed camels and other domestic animals (18). Trees locally called "Al'Ghaf" and "Al'Sidr", their latin equivalents are "Prosopis Spicigera L." and "Zizyphus Spina-Christi Wild" respectively. Their leaves are used for feeding animals, and their trunks are used as poles to set up the beduin tents. They are also sold in urban centres to be used as fuel for cooking purposes (18).

- Sea species

Plants locally called "Al'Mangaroaf" grow by the coast of Abu Dhabi, between the high and the low tide limits. Its branches are used for making interweaved mats. They are used as carpets, rugs and roof lining material in various types of local houses (18).

1.3.3 Local domestic animals

A variety of about six kinds of domestic animals are raised in different areas in Abu Dhabi. Camels are raised mainly for their milk, and as a mount for the owner and his family as well as a beast of burden. The camel is the only item the beduin can sell if he needed money to buy other things. Horses were never widely used in Abu Dhabi as beasts of burden. However, a good horse has always been a precious gift between the tribes sheikhs. Donkeys are mostly used as beasts of burden. Cattle were kept in oases irrigated by "al'aflaj",

where lucerne could be grown under the palm-trees and feed them. They are kept mainly for their milk. Among the domestic animals raised by the local people of Abu Dhabi, both sheep and goats are the mainly raised by settled and beduin families. The goats are useful in many ways. Their milk is turned into curds, their hair is spun and woven into tent material and ropes. It is also knitted into socks. The goats skin is used in making water bags, and in making tent fasteners (19).

1.3.4 Coral reefs

The cost of Abu Dhabi is characterised by a large number of coral reefs. These coral reefs form a natural resource of one of the most important building material. It was used for building local houses on the island of Abu Dhabi and elsewhere by the cost of the emirate. The coral was extracted in the form of lumps, which were left to dry up in the sun of the summer season. These lumps were then cut into blocks to be used in building houses in Abu Dhabi.

1.3.5 Oil

Discovery of oil in certain geological formations under the territory of Abu Dhabi, put it on the international map. Oil served as a bridge of contacts with the rest of the world. Since an ambitious housing policy was taking place in Abu Dhabi, the international contacts provided different fields of knowledge and experience. Along with the discovery of oil which provides the financial power, the housing policy was accelerated to accommodate the maximum number of local families in the shortest period possible. A complete refuge to the foreign experience, along with the need of mass produced houses, resulted in total negligence of the housing conditions which existed before oil was discovered. The housing conditions before oil discovery were natural result of the life givens, whereas housing conditions after oil discovery are highly

influenced by the unadapted applied foreign experiences.

Conclusion

This brief description indicates a vital natural life resource which is water. The location of natural water resources, highly influenced the location choice of the building up human settlements. Three main human centres can then be recognised in Abu Dhabi, which are Abu Dhabi island, Al'Ain area and the Liwa oases. In areas like Al'Ain and the Liwa oases, the palm trees gardens provide a wide range of building materials assembled in the palm tree. Domestic animals in addition to providing milk and meat, provide hair which is woven to make the tent cloth. The several coral reefs extending along the coast of Abu Dhabi, forms a natural resource for one of the main natural building materials which is the coral blocks. One can say that, a collective sample of the forms of natural life resources in Abu Dhabi (water, local trees, domestic animals, coral reefs), forms a self sufficient housing industry. The discovery of oil induced a revolutionary rapid change in the housing policy carried out in Abu Dhabi. International contacts with the outside world, in addition to the powerful financial capabilities provided by the oil market, highly influenced the result of this policy.

1 . 4 C l i m t i c a l c o n d i t i o n s

The climatical conditions of Abu Dhabi are influenced by its geographical location (see Site conditions). The natural site conditions of Abu Dhabi induce very severe climatic conditions, which greatly influence housing in Abu Dhabi. Five main factors form the climatic character of Abu Dhabi, which are :

1.4.1 Temperature degrees

1.4.2 Humidity rates

1.4.3 Surface winds

1.4.4 Sunshine

1.4.5 Rainfall

Due to the different geographical locations of Abu Dhabi city and its rural areas, Al'Ain city and its rural areas. Local climates of both cities are going to be analysed in respect with the five preceding climatical factors.

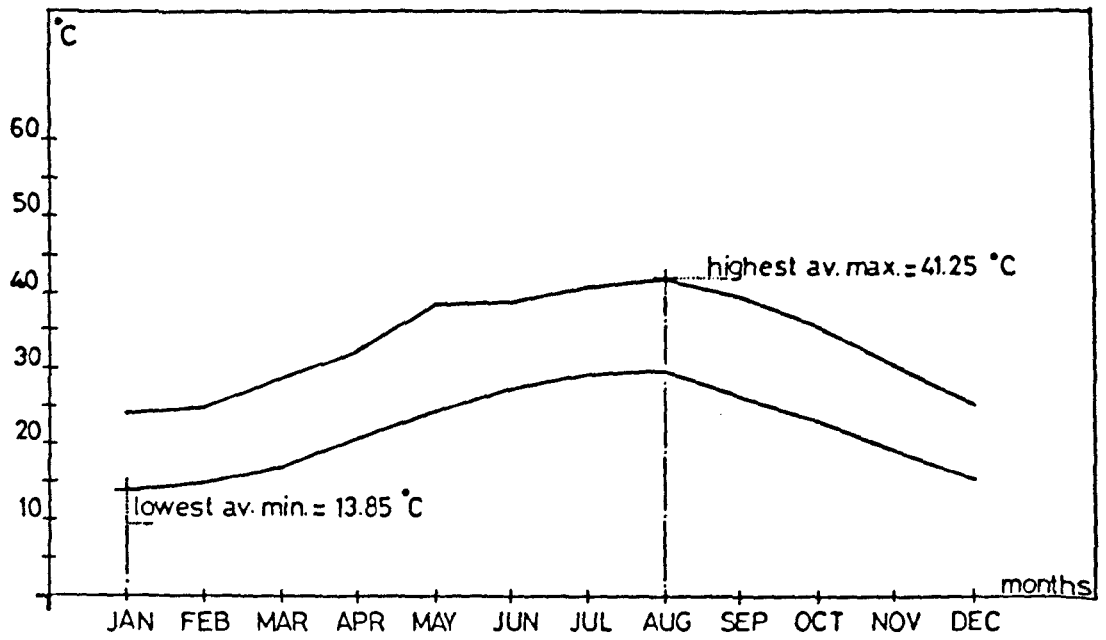

Fig. 13 : A graph that shows the recorded average minimum & maximum temperature degrees for Abu Dhabi city of the years 1985 - 1988 (20).

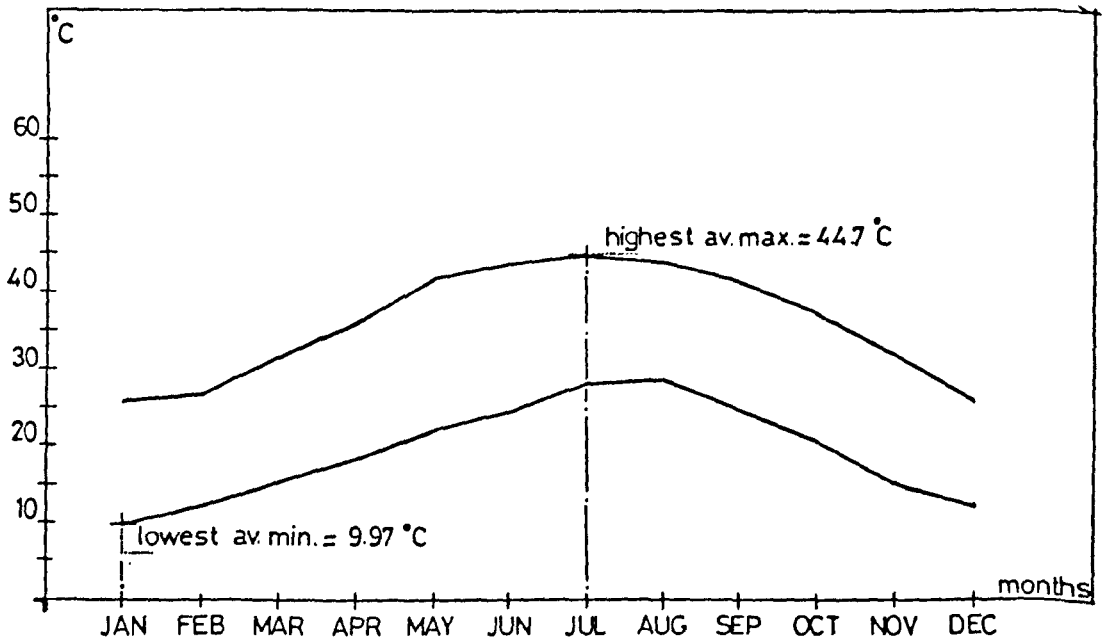

Fig. 14 : A graph that shows the recorded average minimum & maximum temperature degrees for Al'Ain city of the years 1985-1988 (20).

1.4.1 Temperature degrees

Figures 13 & 14 show the recorded average minimum & maximum temperature degrees for Abu Dhabi and Al'Ain cities, respectively. The highest average maximum temperature degree in both cities reaches above 40°C, which is extensively high. High diurnal temperature variations in both cities can be noticed. The range between daily maxima and minima may exceed 13°C in Abu Dhabi, and 20°C in Al'Ain. However, in summer nights temperature degrees may not drop below 24°C in Abu Dhabi, and 22°C in Al'Ain. High seasonal temperature between winter lows and summer highs; 27°C in Abu Dhabi and 34°C in Al'Ain. This brief description of the thermal behaviour of climate in both cities, leads to the fact that both cities are exerted to hot climate most of the year.

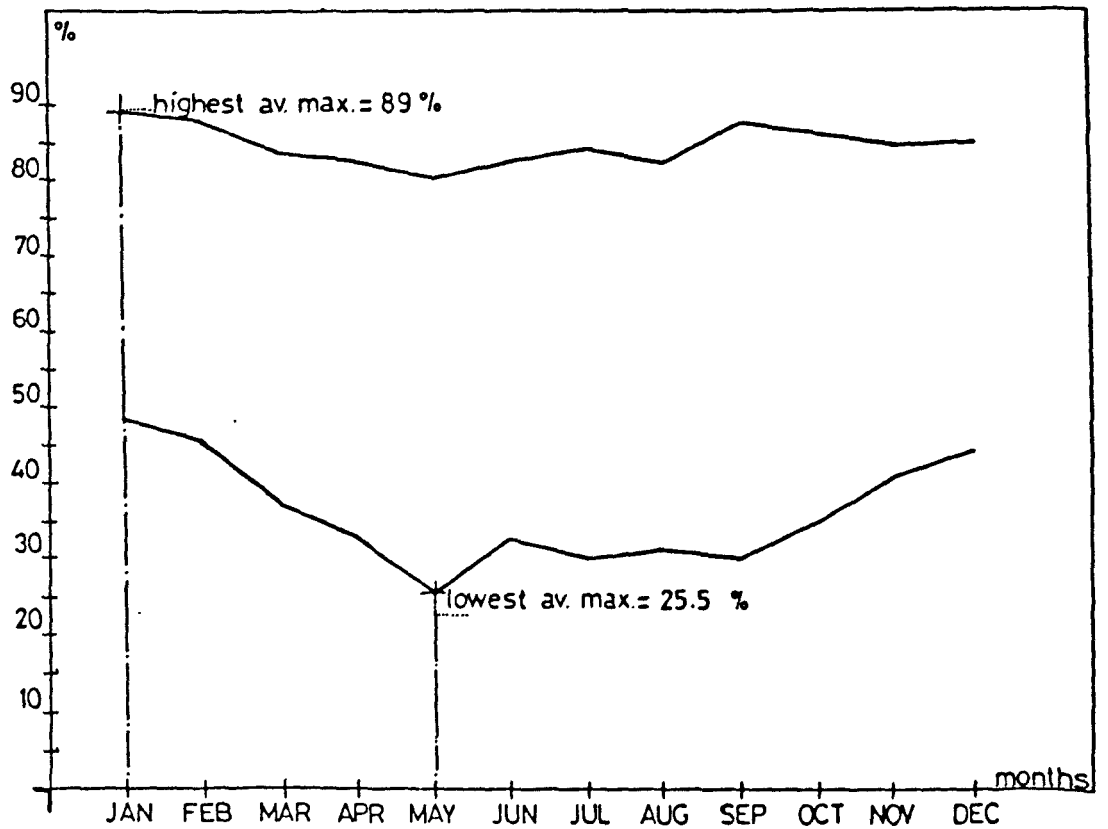

Fig. 15 : A graph that shows the recorded average minimum & maximum relative humidity percentages for Abu Dhabi city of the years 1985 - 1988 (20).

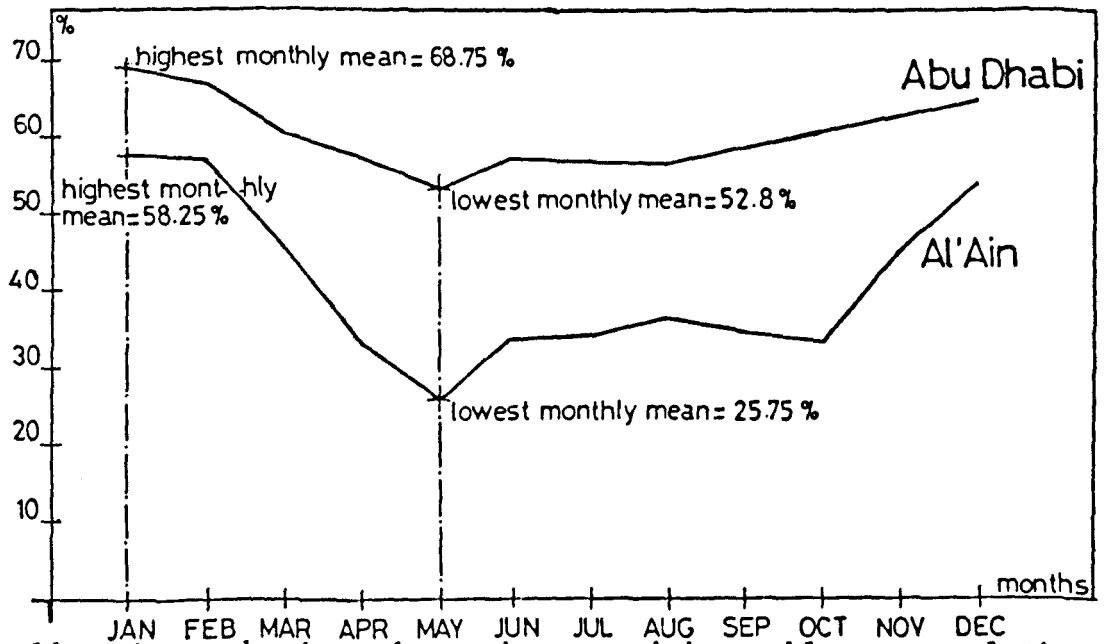

Fig. 16 : A graph that shows the recorded monthly mean relative humidity percentages for both, Abu Dhabi and Al'Ain cities of the years 1985 - 1988 (20).

1.4.2 Humidity rates

Figure 15 shows the recorded average minimum & maximum relative humidity percentages for Abu Dhabi city. The average maximum percentages vary from 80% to 89% all through the year. However, humidity percentages in Abu Dhabi city can sometimes reach 100% (20). Figure 16 shows the monthly mean humidity percentages of both, Abu Dhabi and Al'Ain cities. The curve representing the values of Al'Ain city shows a significant drop in humidity percentages between the months of February and October. The minimum monthly mean reaches sometimes below 26%, where the maximum monthly mean does not reach 60%. The curve representing the values of Abu Dhabi city shows more steady values than the preceding curve. The minimum monthly mean does not reach below 52%, while the maximum monthly mean is around 68%. The comparison represented by the two curves shown in figures 16 leads to the following fact : while Al'Ain city has a fairly dry climate, Abu Dhabi city has a humid climate almost all through the year.

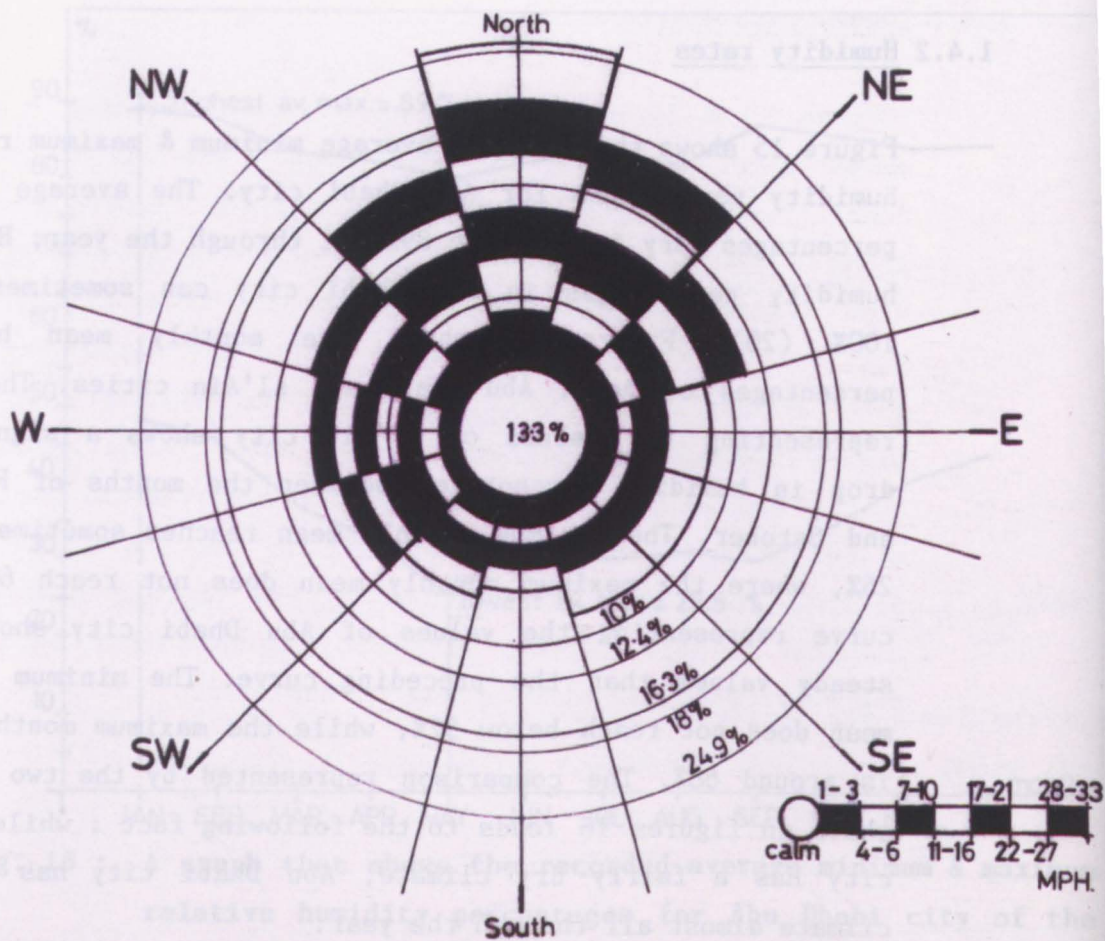

Fig. 17 : The wind rose of Abu Dhabi of the years 1974 - 84 (22).

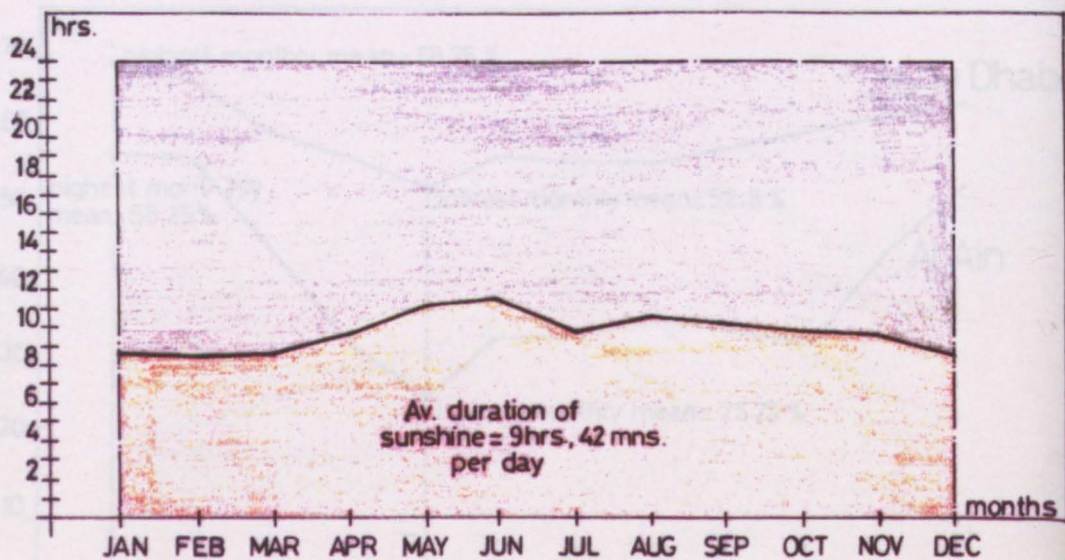

Fig. 18 : A graph that shows the daily average duration of sunshine for each month in Abu Dhabi for the years 1985 - 88 (20).

1.4.3 Surface winds

Figure 17 shows the wind rose for the emirate of Abu Dhabi in general. It shows two main kinds of surface winds, which are :

- First is the northern to north-western dominant prevailing winds. Its source is the mediterrainien sea. It blows all through the year, and increases in winter. It forms about 59.3% of the total recorded directions and wind speeds. The highest recorded gust in Abu Dhabi is 79 mph.(20).
- Second is the southern to south-eastern winds. It is dusty and generally dry. Its source is the desert of "Al'Rub Al'Khali". It blows generally in spring summer season. It forms about 27.4% of the total recorded directions and wind speeds. The highest recorded gust in Abu Dhabi is 39 mph. (20).

1.4.4 Sunshine

Figure 18 shows the daily average duration of sunshine for each month for the emirate of Abu Dhabi. The minimum average recorded duration of sunshine is 8 hrs. and 30 mn. within the month of December. The maximum average recorded duration of sunshine is 11 hrs. and 30 mn. within the month of June. However, the maximum recorded duration of sunshine in one day is 12 hrs. and 30 mn. (20). Long duration of sunshine, clear sky and about 85° vertical inclination of the sun-path above Abu Dhabi in July explain the increase in teperature degrees (21).

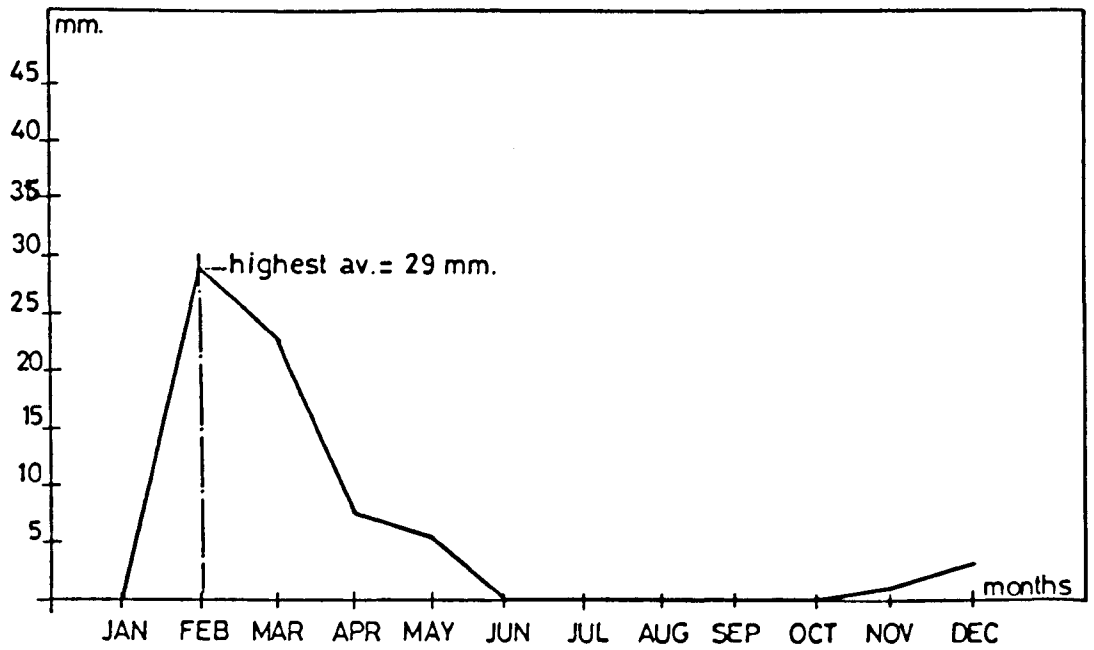

Fig. 19 : A graph that shows the average rainfall in Abu Dhabi city for the years 1986 - 88 (20).

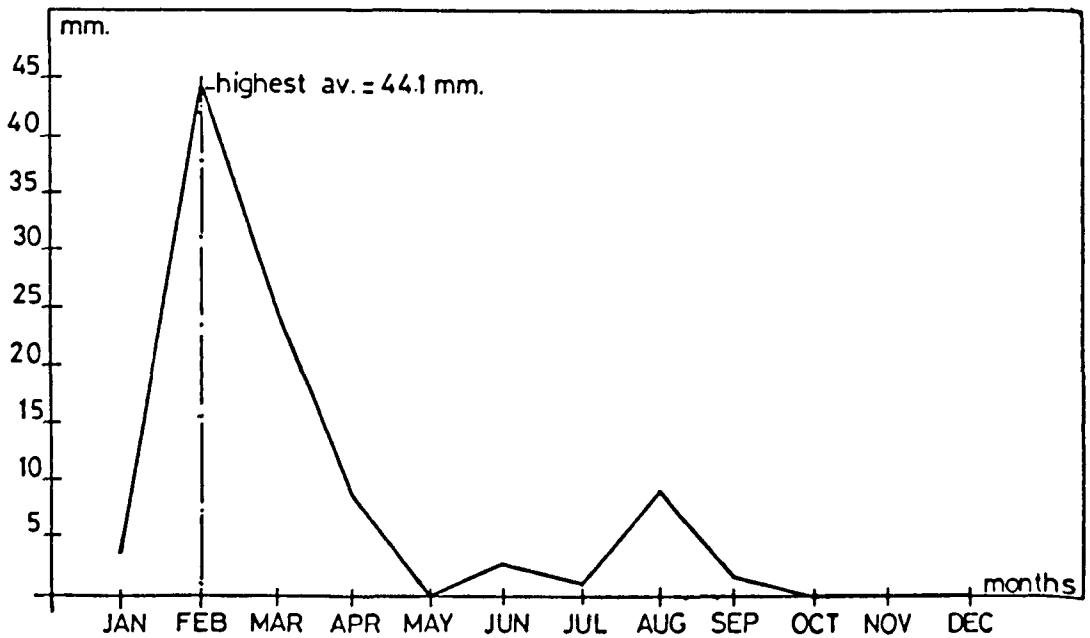

Fig. 20 : A graph that shows the average rainfall in Al'Ain city for the years 1986 - 88 (20).

1.4.5 Rainfall

Figure 19 shows the average rainfall for Abu Dhabi city. The maximum recorded average is 29 mm. . Rain in Abu Dhabi is infrequent and often heavy, where the heaviest recorded fall in one day is 81.5 mm. within the month of February 1988 (20). The expected rainfall period in Abu Dhabi is between January and May.

Figure 20 shows the average rainfall for Al'Ain city. The maximum recorded average is 44.1 mm., nearly one and a half time as much as that for Abu Dhabi. Rain in Al'Ain is also infrequent and often heavy. Rain sometimes results in runoffs which can produce flash floods. The heaviest recorded fall in one day is 88.3 mm. (20). The expected rainfall period in Al'Ain is between January and October.

Conclusion

The former description of the climatical conditions in Abu Dhabi features two main types of the local climate, which are :

- Hot and humid climate in Abu Dhabi city and its rural areas.
- Hot and dry climate in Al'Ain city and its rural areas.

1 . 5 S o c i o - c u l t u r a l b a c k g r o u n d o f t h e l o c a l p e o p l e

Arab tribes are known historically to have lived on the Gulf western coast. They established scattered trading ports along the coast. During the life of the profet Mohammad (571 - 632 A.D.), Islamic religion spread over the Arabian peninsula in general and over the area of Abu Dhabi in particular (23). After a period of eight centuries, almost historically silent, Vasco da Gama discovered the cape route to India in 1497 A.D. (24). The event which brought the area into closer contact with the outside world. Since then, multi-cultured migratory movements rushed the Gulf western coast in general and Abu Dhabi area in particular. In spite of the various cultural backgrounds which was inducted to the area; Arab-Islamic culture is still predominant and the Arabic language is the official language of Abu Dhabi.

The socio-cultural background of the local people is going to be defined through three main points, which are :

- 1.5.1 Social structure and organisation.
- 1.5.2 Demographic analysis.
- 1.5.3 Religious background.

1.5.1 Social structure and organisation

The arab local inhabitants of Abu Dhabi live in tribal society. A tribe consists of clans. The clan is a group of extended families descending from a common ancestor. Traditionally, all tribe members of a given tribe's name have descended from one male ancestor. Tribes vary in size from few extended families to tens of thousands, where the average size of a tribe is four hundred extended families (24). Each extended family is led by a "Sheikh", and each clan is led by the eldest of the families' sheikhs. A tribe consists of a certain number of clans led by a tribal leader. He is the decision maker, and the one who settles tribal disputes with the help of a council made up of elder sheikhs selected from various clans. The tribal leader has considerable power, but he is not an absolute dictator (25). Extended families belonging to one of the clans share the same house. An extended family sharing the same house usually consists of grand parents, parents and their children. Often the male of the middle generation has taken over from his father as the effective head of the family. It was not common for two or more brothers to remain with their wives and children in the same family house of the father. Usually one of them builds his own house, which will soon become the house for other members of the family (26). Extended families, belonging to various clans and tribes, live within two different types of societies, which are :

- "Badawy"; (nomadic) society.
- "Hadary"; (urban) society.

"Badawy" (nomadic) society

The "Badawy" type of society in Abu Dhabi is of two main types, which are :

- Type one :

This type is the permanently travelling tribesmen. They move from one place to the other looking for forage and water for their camels and cattle herds. They live in tents

locally called "Biute al'Shaar". An example for this type is "Al'Awamer" tribe.

- **Type two :**

This type is the versatile tribesmen. They live near by the oases and known water resources. They are in permanent contact with both farmers' and fishermen's villages. In the dry season they move to either type of villages. They participate in either farming or fishing activities. They live in simple forms of the palm-frond tents called "Khaimat al'Saaf". When their economical situation improves by owing a good herd of goats or camels, they go back to the nomadic life. An example for this type is "Bani Qotb" tribe.

"Hadary" (urban) society

The "Hadary" society in Abu Dhabi is of two main types, which are :

- **Type one :**

Type one is that of the tribesmen living on the coast of Abu Dhabi. Their major activities are fishing, pearl diving and trading. They live in elaborate palm-frond tents, locally called "Khaimat al'Saaf". A minority of these tribesmen are the owners of the fishing fleets or the pearl merchants. They live in the most elaborate house type, locally called "Bait al'Sahel". An example for this type is "Bani Yas" tribe.

- **Type two :**

Type two is that of the tribesmen living on the main land of Abu Dhabi. Their major activities are farming and raising domestic animals. They live in the above mentioned "Khaimat al'Saaf". This type of house was the predominant type of house inhabited by most of the families, both living on the coast and in the interior (27). A minority of these tribesmen are the owners of the date gardens. They live in mud-brick houses. An example for this type is "Al'Dhawaher" tribe.

YEAR	POPULATION	RATE OF GROWTH IN %
1968	45136	-
1975	54886	21.6
1980	90792	65.4
1985	133397	46.9
1986	144068	7.9
1987	155593	7.9
1988	168040	7.9

Fig. 21 : A table that shows the local population of Abu Dhabi in the above mentioned years, and their corresponding rate of growth (28).

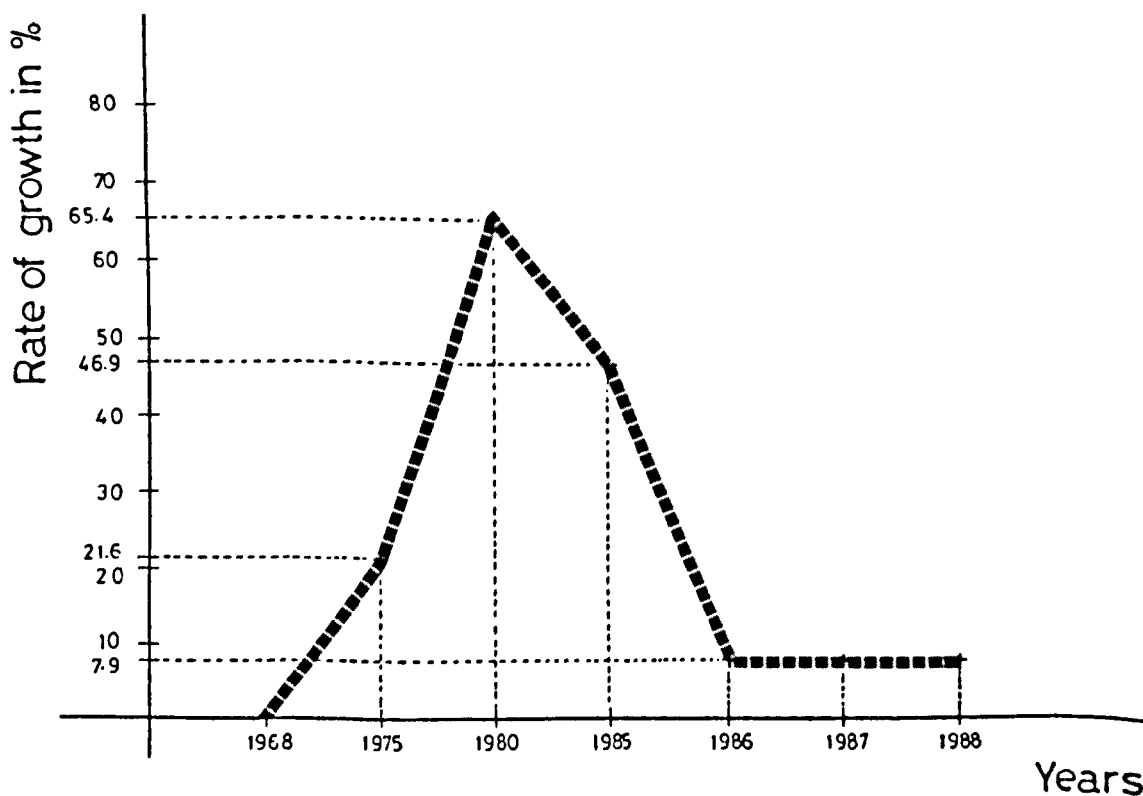

Fig. 22 : A line chart that shows the local population rates of growth and their corresponding years.

1.5.2 Demographic analysis

The population of Abu Dhabi, as given in the censuses of the years 1968, 1975, 1980 and 1985 - 88, is presented in Fig. 21. Population growth in the 1960's in Abu Dhabi was very slow. The exploitation of the discovered oil in Abu Dhabi and the investment of its revenues internally resulted in a rapid population growth (see Fig. 22). The population of Abu Dhabi more than tripled in the period from the year 1968 to the year 1988 (see Fig. 23). In spite of the high rate of growth of the local people, they are still by far less in number than foreigners living in Abu Dhabi (see Fig. 24). This difference in number is due to the heavy influx of immigrants which rushed Abu Dhabi after the discovery of oil. The local people are relatively young, where about 39% of Abu Dhabi population in 1968 were under 16 years old. The sex distribution among the different age classifications is balanced. Males form 55.4% and females form 44.6% of the total population of Abu Dhabi (see Fig. 25). Family sizes are variable in Abu Dhabi. Four main family sizes and their approximate percentages, of the total number of local families living in Abu Dhabi, are shown in Fig. 26.

1.5.3 Religious background

There are no known records of how and when Islam came to the tribes of the United Arab Emirates in general, and to Abu Dhabi in particular. It was probably simultaneous with the well documented conversion of Oman and Al'Bahrain. Before Islam the majority of the population were worshippers of the moon or the stars. The rest of the population may have been under the influence of the beliefs of the frequent Persian invaders (30). The conversion of the local people to Islam and its emphases on their values of privacy, influenced the design of houses in Abu Dhabi in the following manners :

- The house has two separate entrances; a family entrance

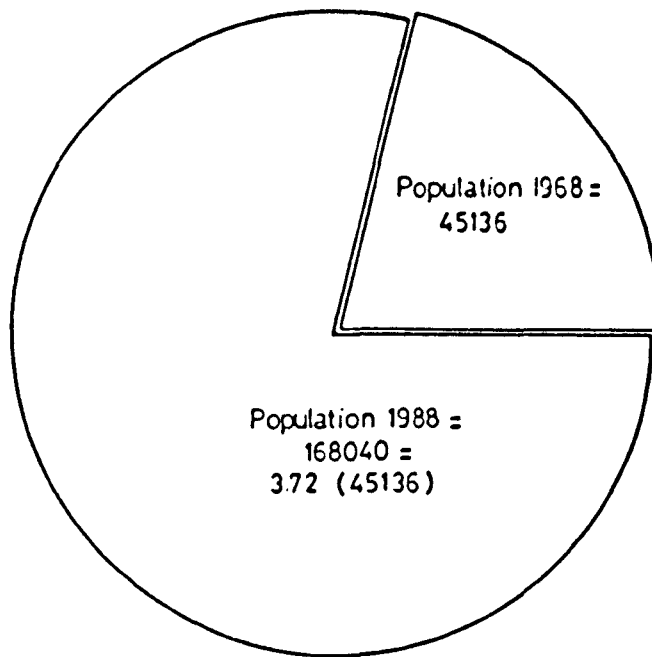

Fig. 23 : A pie chart that shows the difference between the population of the year 1968 and that of 1988.

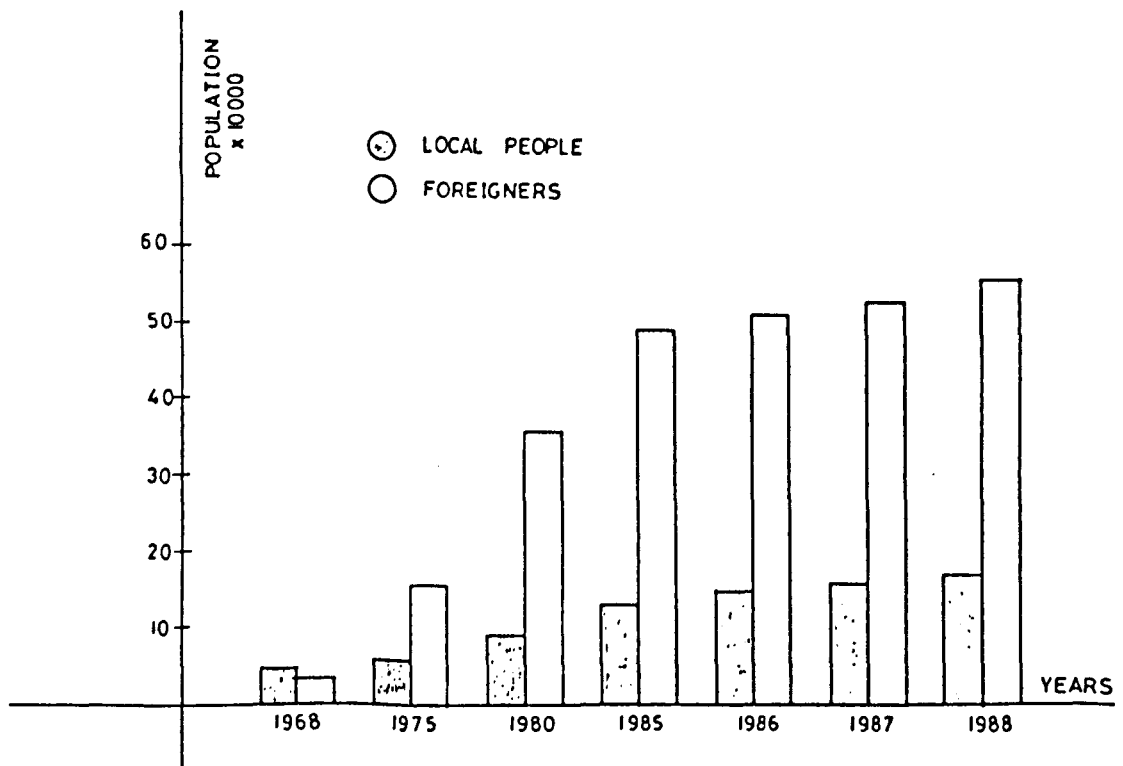

Fig. 24 : A bar chart that shows the population of the local people in comparison with that of the foreigners living in Abu Dhabi, and their corresponding years (28).

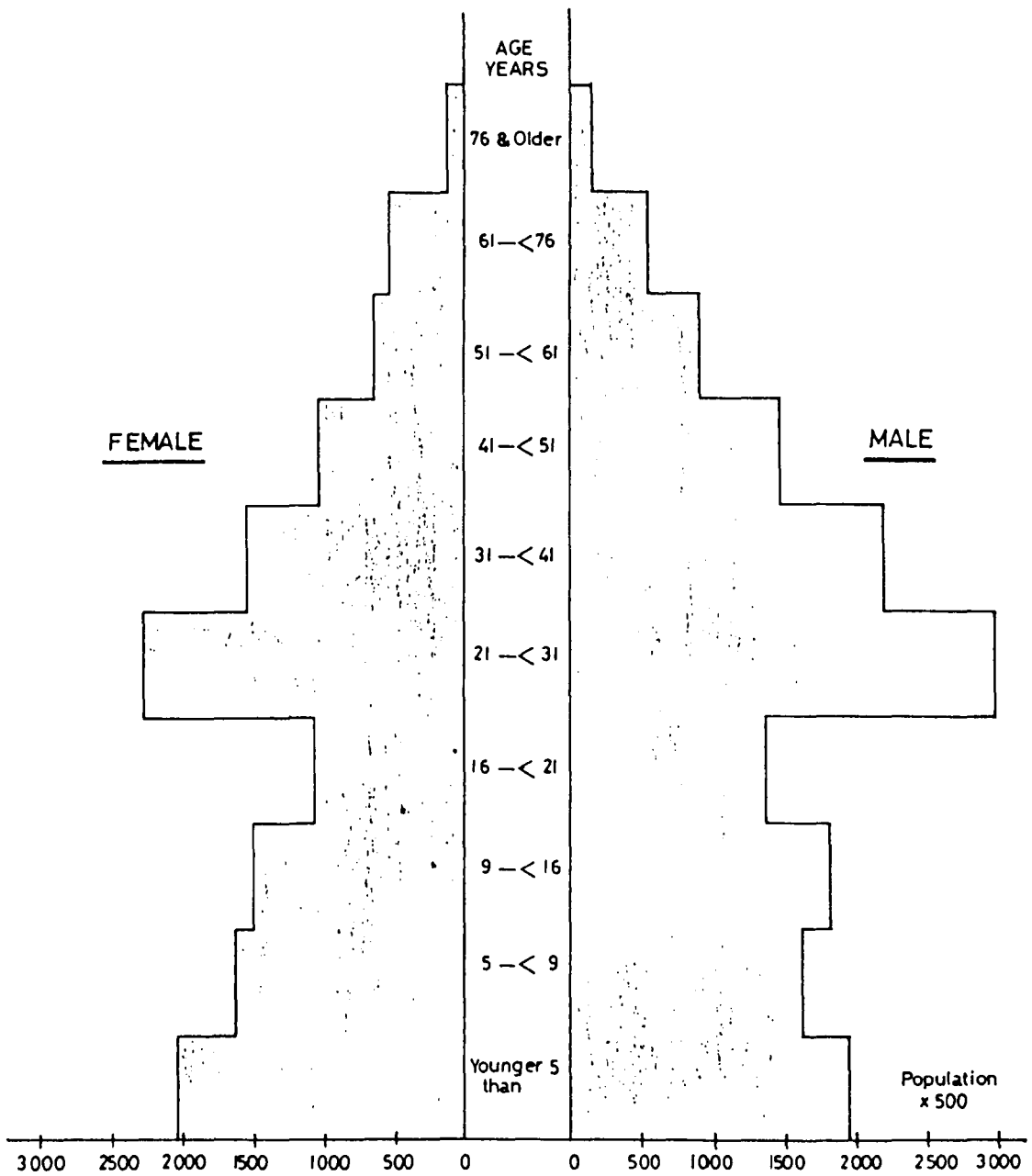

Fig. 25 : A population pyramid that shows the sex distribution among the different age classifications of the local people in Abu Dhabi of the year 1968 (28).

Note : Census information is classified material in Abu Dhabi (25). Thus detailed information on the sex distribution of the local people after the 1968 census is not available.

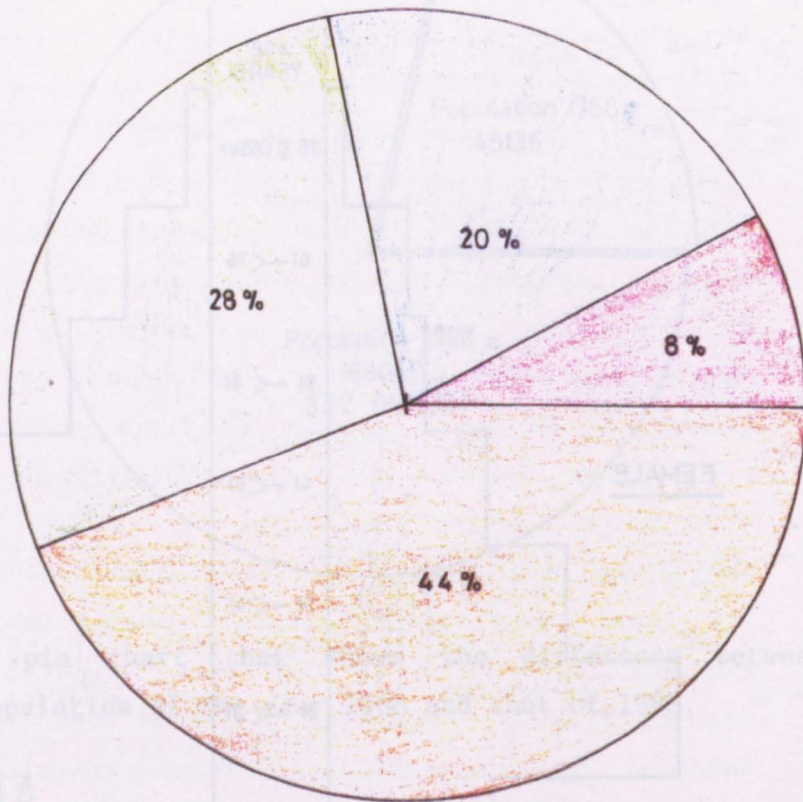

Fig. 26 : A pie chart that shows the four main groups representing different family sizes and their percentages in the society of Abu Dhabi respectively (29).

Key :



size "A" = 1-3 persons
(widows, divorced women)



size "B" = 4-6 persons



size "C" = 7-9 persons



size "D" = 10 or more persons

and a guest entrance. Therefore, providing a private family access to the house separate from that of the male guests.

- Segregation between family women and strangers endeavours to restore to women their honour as members of the family rather than objects of exchange (31). This required the provision of a guests/men's zone and a family/women's zone. The latter is defined in Islam as "Harim". According to the Encyclopaedia of Islam, "Harim" is a term applied to those parts of the house to which access is forbidden, and hence more particularly to the women's quarters (32). Only a father, a brother, a son and possibly other very close male relatives and also foster-brother may proceed beyond the guests/men's zone "al'majlis" to sit and speak face to face with the women of the house. On the other hand, none of the family females who have reached the age of puberty is allowed to enter "al'majlis" while there are guests (31). They are also not allowed to share the same bed rooms with their brothers who have reached the age of puberty and vice-a -vise.
- The state of male servants in the house, particularly since they were rarely of Arab tribal origin, was partly that of a close member of the family in that they had access to most areas of the house when they were expected to serve coffee, to clean, or to do other duties; but the women nevertheless pulled their veils over their faces on the approach of any but the oldest and most trusted servants, and they rarely had a long conversation with a servant (33). This required a service zone for the servant's room and the kitchen, separated from the two other zones.

Conclusion

The society of Abu Dhabi is an Arab, Islamic society based on tribal structure of hierarchical social organisation. The local people live within two types of societies; the "Badawy" and the "Hadary". The nature of the daily life of each society highly influenced the

types of houses of the local people. The "Badawy" (nomadic) society lives in "Biute al'Badu", and the "Hadary" (urban) society lives in "Biute al'Hadar". Absolute privacy is the most important requirement the house design has to achieve. The family size of the local people varies from three persons to an extended family of ten or more persons. This fact highlights the need to provide convenient houses that meet the needs of each family type and size.

1.6 Economy and housing policy in Abu Dhabi

Since the end of the 19th century, Abu Dhabi has witnessed two main economy booms. These economy booms influenced housing policy in Abu Dhabi.

1.6.1 The first economy boom

The first economy boom was the result of the flourishing pearl industry. Many of the formerly beduin tribesmen used to stay in the city of Abu Dhabi in winter. They could afford to live off the money they earned from pearling in summer (34). The prosperous pearl industry attracted a great number of beduin families towards living by the coast of Abu Dhabi. The growing foreign demand for pearls at the end of the 19th century meant ever-increasing profits were being made. Beduins participated in a pearling cooperative organised on their tribal basis and earned more money. This resulted in a growing number of families who could afford to buy their own pearling boats and even make enough profit in a season or two to build a good two-story house in Abu Dhabi city (34). The pearl divers working the boats used to live in palm-frond houses. This palm-frond houses was the predominant type of house inhabited by most families, both living on the coast or in the interior (34). On the other hand some of the beduin families could buy more camels, or established date gardens (34). These beduin families who became the owners of the date gardens often lived in two-story mud-brick houses, while their gardeners lived in palm-frond houses (35).

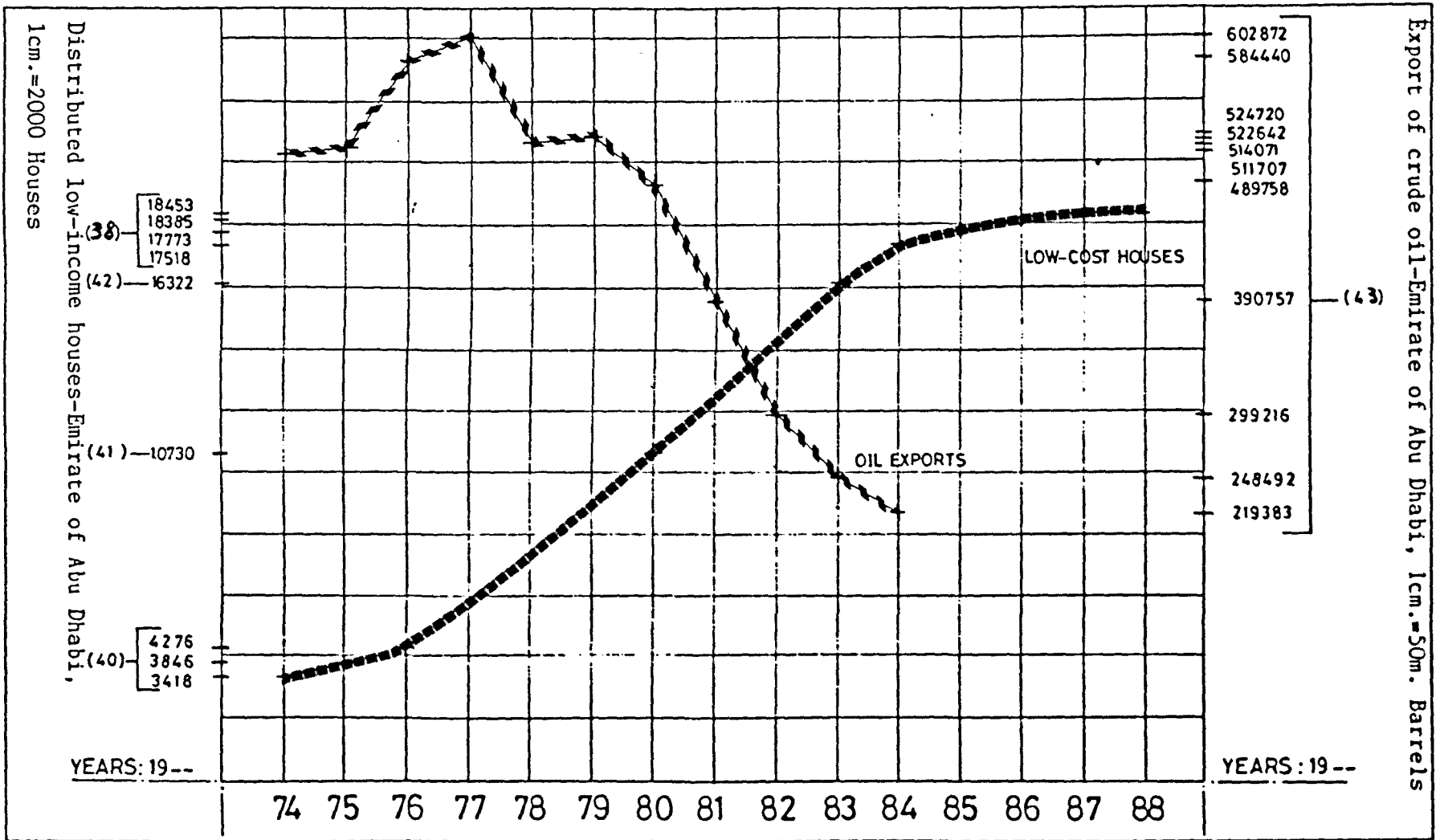

Fig. 27 : A line chart that shows the relation between crude oil exportations & distributed low-income houses in Abu Dhabi

1.6.2 The second economy boom

The second economy boom was the result of the oil discovery in Abu Dhabi and the ever increasing revenues of oil exports. Oil was discovered in commercial quantities on 28th October 1960 at Murban in Abu Dhabi (36). In the late 1960's, as the economy expanded, the more wealthy of the local people were able to build new houses to replace the windtower house and the mud-brick houses they had previously lived in. The great majority of the local people could not afford to build their own houses and settle down. Therefore, the government started to supply them with new houses. These houses which are built in concrete are provided with electricity, sewage disposal, and running water. An ambitious plan started in 1966 to provide the local people with low income houses. By the year 1976 (see Fig. 27) some 5000 low income houses had been given to local families in Abu Dhabi city, Al'Ain city, and new villages built to settle the beduin population along the Abu Dhabi - Al'Ain road (37). After the public works department, housing and town planning were combined under one ministry in Abu Dhabi, the implementation of this housing plan was speeded up. By the year 1988 some 18453 low income houses had been given to local families in the emirate of Abu Dhabi (38).

Conclusion

The local families have been always looking forward to settle down. The economy boom caused by the prosperity of the pearl industry allowed a great number of local families to build their own houses and settle down. The general economic situation before the discovery of oil was not solid enough to develop a national housing programme. The second economy boom caused by the discovery of oil, somehow,

gave a second chance for an old dream to come true. The government of Abu Dhabi developed an ambitious programme to provide local people with a proper environment. Most of the windtower houses, mud-brick houses, and palm-fronds houses had been replaced by low income modern houses. Suburban villas were being built where previously people lived in palm-frond houses. The crooked alleys and open spaces between old quarters had been obliterated by straight dual carriageway roads slicing towns and the surrounding countryside into neat rectangles with roundabout or traffic lights at each intersection. The speeding up of this programme, resulted in insufficiently studied layouts of mass produced low income houses. Each of these low income houses costs an average of 130000 Derhams, which is equivalent to the sum of 19200 Pounds Sterling (39). This programme was a very decisive step towards the transformation of the way of living of a large number of local families (37).

List of Quotations

- (1) Fisher, W. B., "The Middle East: A Physical, Social and Regional Geography", London, 1952, pp 439-44
- (2) Reproduction by the author from: Heard-Bey, F., "From Trucial States to United Arab Emirates", London, 1984, pp 7
- (3) *ibid*, p 523
- (4) Department of Planning, "Statistical Year Book", Abu Dhabi, 1984, see introduction
- (5) Heard-Bey, F., "From Trucial States to United Arab Emirates", London, 1984, pp 10-14
- (6) Reproduction by the author from: "Projects, G. E. O., "The Oxford Map of the United Arab Emirates", in association with Oxford University Press, Beirut, 1972, p 2
- (7) Tourism and Heritage Department, "Tourism in the U.A.E.", Abu Dhabi, 1975, p 17
- (8) Reproduction by the author from: Heard-Bey, F., "From Trucial States", p 30
- (9) Heard-Bey, F., "From Trucial", p 245
- (10) Reproduction by the author from: Heard-Bey, F., "From Trucial States", p 20
- (11) Tamara Publications, "Dubai Visitor", Dubai, 1992, p 13
- (12) El'Abdouly, K. G., "Prevailing Trends in the Architecture of the United Arab Emirates", Abu Dhabi, 1989, p 77
- (13) Heard-Bey, F., "From Trucial", p 307
- (14) *ibid*, p 367
- (15) *ibid*, p 178
- (16) El'Hagag, Y.A. et al, "The United Arab Emirates - A comprehensive surveyal study", Cairo, 1978, p 205 (Title translated by the author)
- (17) Heard-Bey, F., "From Trucial", p 176
- (18) El'Hagag, Y.A. et al, "The United", pp 186-90
- (19) Heard-Bey, F., "From Trucial", pp 165-70
- (20) Department of Planning, "Statistical Year Book", Abu Dhabi, 1988, pp 3-12
- (21) Information extracted from the author's notes on lectures by Soliman, B.M., "Selected Subjects in Urban Design", the

Department of Architecture, U.A.E. University, Al'Ain, course no. 73564, 1986/87 (not published)

- (22) Reproduction by the author from: Afifi, A. K., and Sarhan, A. E., "The effect of climatic factors on Urban Design in the U.A.E.", a research paper presented at the U.A.E. University, Al'Ain, 1985, p 3 (not published)
- (23) Howeedy, M. A., "A Study Suggesting Contemporary Urban Design Guidelines Using The United Arab Emirates As An Illustrative Case", Masters thesis, Michigan, 1989, p 56
- (24) Juma, M. A., "Urban Development In The United Arab Emirates And In Abu Dhabi City", M.Sc. thesis, Michigan, 1985, pp 1, 3, 14
- (25) Howeedy, M. A., "A Study", pp 62, 63
- (26) Heard-Bey, F., "From Trucial", p 152
- (27) *ibid*, p 192
- (28) Department of Planning, "Statistical Year Book", Abu Dhabi, 1968, pp 1-11, 1988, p 53
- (29) Department of Planning, "Post-Occupancy Housing Survey", Abu Dhabi, 1987, p 116
- (30) Heard-Bey, F., "From Trucial", p 126
- (31) *ibid*, pp 144-45
- (32) Brill & Luzac, "The Encyclopaedia of Islam", new ed, Leiden, London, 1971, vol III, p 209
- (33) Heard-Bey, F., "From Trucial", p 434
- (34) *ibid*, p 192-200
- (35) *ibid*, p 237
- (36) *ibid*, p 307
- (37) *ibid*, p 385
- (38) Department of Planning, "Statistical", p 267
- (39) A personal interview carried out by the author with Matloob, A., Abu Dhabi, 1992
- (40) Department of Planning, "Statistical", 1976, p 116
- (41) *ibid*, 1986, p 254
- (42) *ibid*, 1987, p 277
- (43) *ibid*, p 75

List of Figures

- Figure 1/1 : A map that shows the United Arab Emirates location.
- Figure 1/2 : A map that shows the United Arab Emirates.
- Figure 1/3 : A pie chart that shows the area percentage of each emirate with respect to the whole U.A.E. area.
- Figure 1/4 : A table that shows the emirates areas and their percentages respectively.
- Figure 1/5 : A map that shows Abu Dhabi island.
- Figure 1/6 : A photograph of the interlinking sand dunes of Abu Dhabi's desert.
- Figure 1/7 : A map that shows Abu Dhabi's main geographical features.
- Figure 1/8 : A map that shows the three main population centres of Abu Dhabi emirate.
- Figure 1/9 : A map that shows "Khamir" in the Bastak district, from which the Arab merchants immigrated to Dubai.
- Figure 1/10 : A photograph that shows the wind-tower houses of "Al'Bastakeyah" quarter, by the creek of Dubai.
- Figure 1/11 : A photograph that shows the wind-tower houses in one of the cities of Persia.
- Figure 1/12 : A sketch that shows a longitudinal section passing through "al'falaj".
- Figure 1/13 : A graph that shows the recorded average minimum & maximum temperature degrees for Abu Dhabi city of the years 1985 - 88.
- Figure 1/14 : A graph that shows the recorded average minimum & maximum temperature degrees for Al'Ain city of the years 1985 - 88.
- Figure 1/15 : A graph that shows the recorded average minimum & maximum relative humidity percentages for Abu Dhabi city of the years 1985 - 88.
- Figure 1/16 : A graph that shows the recorded monthly mean relative humidity percentages for both, Abu Dhabi and Al'Ain cities of the years 1985 - 88.
- Figure 1/17 : The wind rose of Abu Dhabi of the years 1974 - 84.
- Figure 1/18 : A graph that shows the daily average duration of

sunshine for each month in Abu Dhabi, for the years 1985 - 88.

- Figure 1/19 : A graph that shows the average rainfall in Abu Dhabi city for the years 1986 - 88.
- Figure 1/20 : A graph that shows the average rainfall in Al'Ain city for the years 1986 - 88.
- Figure 1/21 : A table that shows the local population of Abu Dhabi in the above mentioned years and their corresponding rate of growth.
- Figure 1/22 : A line chart that shows the local population rates of growth and their corresponding years.
- Figure 1/23 : A pie chart that shows the difference between the population of the year 1968 and that of 1988.
- Figure 1/24 : A bar chart that shows the population of the local people in comparison to that of the foreigners living in Abu Dhabi and their corresponding years.
- Figure 1/25 : A population pyramid that shows the sex distribution among the different age classifications of the local people in Abu Dhabi in the year 1968.
- Figure 1/26 : A pie chart that shows the four main groups representing the different family sizes and their percentages in the society of Abu Dhabi respectively.

Chapter Two

Housing types & methods of construction in Abu Dhabi

In this chapter an analytical study of the feasibility of houses built in Abu Dhabi will be carried out. Houses built before and after the discovery of oil will be described, then analysed through out the following aspects:

- Functional - Socio-cultural - Technical - Environmental

The post-occupancy housing survey carried out by the Planning Department of Abu Dhabi will be taken into consideration. The conclusion of this analytical study will assist in establishing the criteria of housing design in Abu Dhabi. This chapter is structured as follow:

- 2.1 Analysis of the (social, environmental, etc. ...) feasibility of the houses built before the discovery of oil & conclusion
- 2.2 Analysis of the (social, environmental, etc. ...) feasibility of the houses built after the discovery of oil & conclusion
- 2.3 Post-occupancy housing survey carried out by the Planning Department of Abu Dhabi
- 2.4 Conclusion

2.1 Analysis of the (social, environmental, etc.) feasibility of the houses built before the discovery of oil

Due to environmental, social and other conditions influencing housing in Abu Dhabi, local people developed several types of houses. Both kinds of inhabitants, al'Badu and al'Hadar (see socio-cultural background of the local people, chapter one), constructed their houses utilising natural building materials. Their houses reflect their social behaviour patterns, and adapt to the existing environmental conditions of Abu Dhabi. Therefore, two main types of houses can be recognised in Abu Dhabi, which are :

2.1.1 Biute al'Badu

Biute is the plural of "bait". The term "bait" means house , so "biute al'badu" means beduin houses, locally called "houses of hair".

2.1.2 Biute al'Hadar

The term "al'hadar" means the local people living either in rural or urban areas, so "biute al'hadar" means houses of the local people living in rural or urban areas. There are two main types of "biute al'hadar", which are :

a) Biute al'Sahel

The term "al'sahel" means coast, which refers in this research to the coast of Abu Dhabi and any of its islands. So "biute al'sahel" means houses built on the coast.

b) Biute al'Burr

The term "al'burr" is the local name given for Abu Dhabi's main land. So "biute al'burr" means houses built on the main land of Abu Dhabi.



Fig. 1 : A photograph that shows the house of hair (2)

2.1.1 Biute al'Badu

Biute al'Badu are locally called "Biute al'Shaar", which means "houses of hair". They are the most wide spread type of black tent designs (see Fig. 1). These tents are rectangular in shape, and are set up in groups of three, four or more tents forming a compound. The number of tents in a compound depends on the number and sizes of the families living in the same compound. The distance between each two tents is covered in an average time of 20 to 25 minutes on foot. Thus defining the territory of each household. If two tents are pitched so that their ropes cross, the households are united in some way (1).

An example for one of "biute al'badu" is shown in figure 2. Biute al'badu consist of three main zones (see Fig. 3), which are:

- 1) Family/women's zone
- 2) Guests/men's zone
- 3) Services zone

Both family/women's zone and guests/men's zone are enclosed within the tent's area. The guests zone is usually smaller in area than the family zone. The two zones are separated by a common dividing curtain wall, locally called "al'qata". This curtain wall extends outside the tent. Thus dividing the tent's front area into family outdoor area, and guests approaching area. Entrances to both zones are laid on the same side of the tent. The family entrance and the guests entrance are laid to the left and the right of "al'qata" respectively. The area surrounding the tent, which lies between the tent curtain walls and the tent stakes, is locally called "al'rowag". The services zone is divided into two parts. The first part is for cooking and food storage. The second part is for keeping goats, sheep and fodder storage. While the first part is integrated within the family/women's zone, the second part is completely separated from the tent.

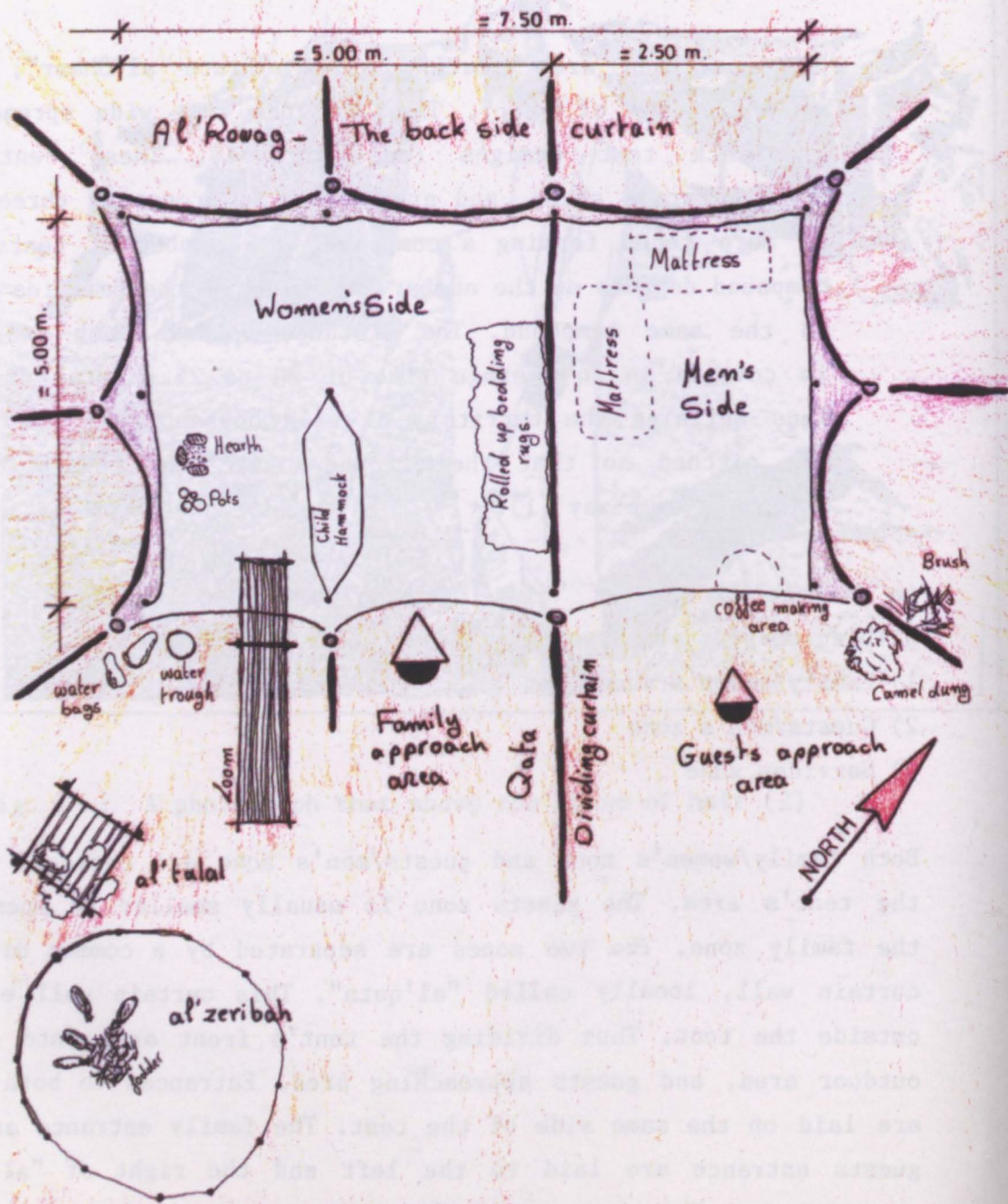

Fig. 2 : An example for "Biute al'Badu" - Houses oh Hair (3).

Note : This drawing is not to scale; dimensions shown are approximated.

Each zone of this type of houses, "biute al'badu", consists of a multi-functional space, which are as follow:

1) Family/women's zone

The family/women's zone consists of one multi-functional space. In this space most of the family's every day life activities take place. The women talk, cook, and weave on their side . In the family zone, a sleeping area is encircled with a border of stones against the dividing curtain wall "al'qata". The women stack rolls of bedding and sleeping rugs against the feet of "al'qata". A hammock cradle may be stretched between two tent poles as the baby's sleeping place. The camel litter, locally called "al'mahmal", is kept in one of the corners of the family zone. Near the opposite wall to "al'qata" is the cooking and storing area. The grain and wool sacks are stored on a bed of stones on one side, while saddle bags are hooked to the top of the tent poles. The cooking area lies between the storing area and the family outdoor space. It consists of a cooking hearth made of three stones with iron bars set across to support the cooking pots and bread pans. Outside the tent, near the front corner, goat skin water bags are laid on a bed of bushes. Next to the water bags a tripod suspends a goat skin churn used to agitate milk to form butter. Finally the loom used for weaving the tent cloth is set up with the warp running out of the front of the tent (1).

2) Guests/men's zone

The guests/men's zone consists of one multi-functional space, locally called "al'majlis". In this area the family male receives his guests. Guests can also eat and sleep in the same area. The floor of the guests area, "al'majlis", is covered with carpets and mattresses for the guests to sit on. The host's camel saddle, covered with sheep skin, is set on the rear mattress. The host and the guest of honour sit on either side of it and talk across; the other guests sit in a semicircle facing them. A small hearth is set just outside the tent to brew the coffee for the guests (1).

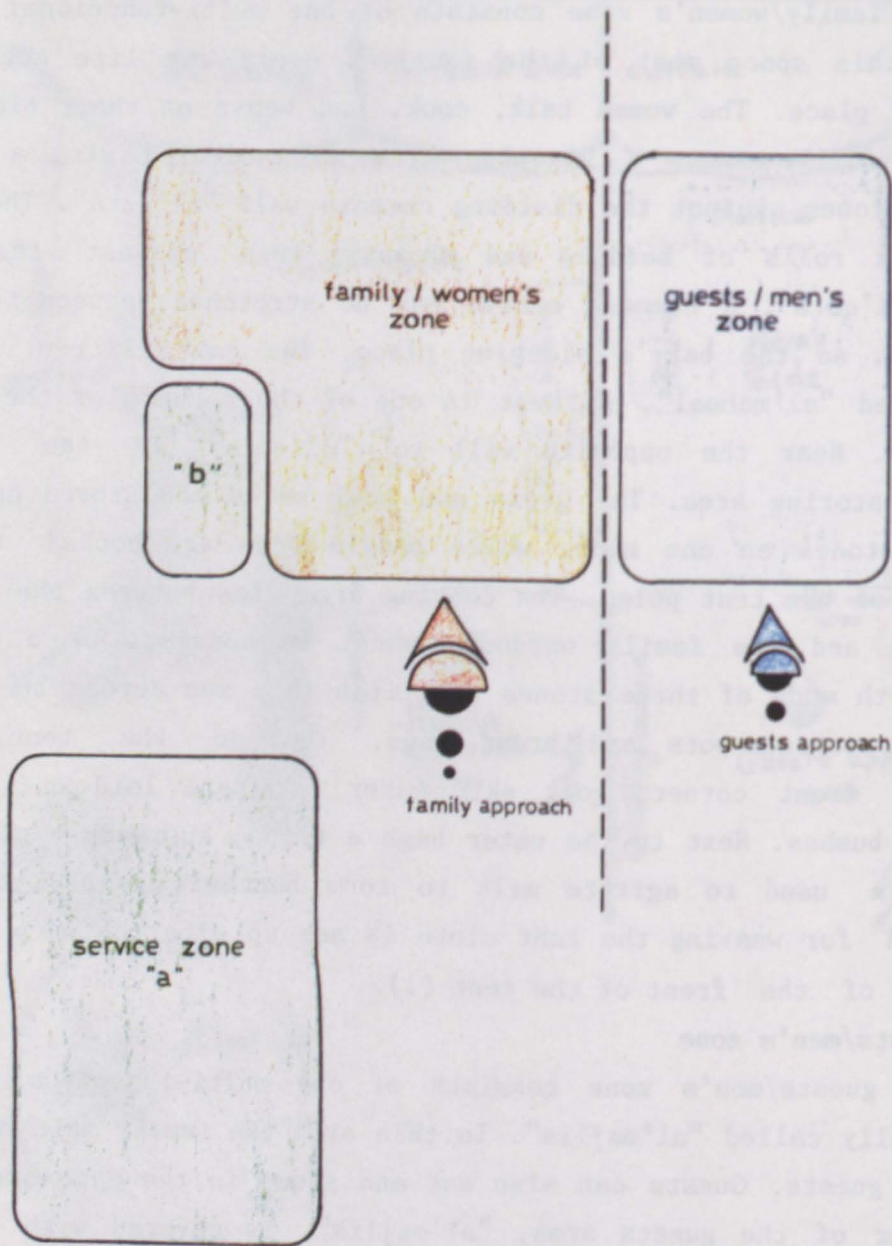

Fig. 3 : A diagram that shows the different zones of "Biute al'Badu".

3) Services zone

The services zone consists of three main parts, which are :

- a ranch called "zeribah"
- a store called "talal"
- a water well called "towey"

The first two parts lie next to the family/women's zone, while the third part "al'towey" lies in a central place compared with the compound. The water well is the property of the tribe to which the compound belongs to.

The Zeribah

The "zeribah" is an area to keep the goats and the sheep. It is encircled with a demountable fence (see Fig. 4). The fence is made of wooden poles tied together sequentially at intervals by two lines of weaved ropes. The poles are fixed in the ground forming a circular enclosure. Pieces of woven cloth are hung on the upper rope covering the space between each two poles.

The Talal

The "talal" is a wooden platform of square shape (see Fig. 5). It has an area of about one square metre. It is raised about one metre above the ground level by four wooden poles, each fixed to one of the corners. It is erected next to "al'zeribah". The "talal" is used to keep cooking pots and dried up food above the ground level.

The Towey

The "towey" is a potable water well. It is a hand dug well which provides washing, cleaning and drinking water (see Fig. 6). The water well is encircled with stones to indicate its location and prevent it from being filled with sand. Two wooden poles are fixed to the ground and tied together across the well supporting a wooden pulley (see Fig. 7). Hanging on the pulley is a woven rope, which to one of its ends a water goat skin bag is tied. This bag is used to raise water from the well. A



Fig. 4 : A photograph, shot by the author, that shows "Al'Zeribah".



Fig. 5 : A photograph, shot by the author, that shows "Al'Talal".

third wooden pole is fixed perpendicularly to the ground at few feet away from the well. The three poles form a triangle which its base is located across the well. The third wooden pole connected with a woven rope to the two other poles, supports the whole structure while drawing water from the well.



Fig. 6 : A photograph, shot by the author, that shows "Al'Towey".



Fig. 7 : A photograph, shot by the author, that shows "Al'Towey".

Functional Aspect

The house of "bait al'badu" is divided into three main zones (see Fig. 3). Each one of these zones has a certain function. They are as follow:

1) Family / women's zone

It contains the family living area, where all the family share the same space.

2) Guests / men's zone

It contains the male guests reception, locally called "al'majlis", where male members receive and host their male freinds and visitors.

3) Service zone

It contains the services needed to assist life in the beduin house, such as: cooking and storing areas, a small ranch for keeping sheep and goats.

These three zones are laid out together in order to maintain the required functional performance of each one of them. Their layout gauranties an uninterrupted flow of circulation between them (see Fig. 8). It also allows the family members ,males and females, to have direct access to either of their zones. Accessibility between the family / women's zone and the service zone is maintained by passing through the family approach area. Guests have direct access to the guests / men's zone through the men's approach area. Wherefor, strangers are not allowed to pass through neither the family / women's zone nor the service zone. Male members of the family have an indirect access, from the family / women's zone, to the guest / men's zone turning around "al'qata" dividing curtain wall.

In figure 9, the house of "bait al'badu" is divided into layers based on the equal number of movements leading to different spaces among it. This number of movements is in relation to the desert open space. The more number of movements needed to reach a certain space inside the house, the deeper the space is. Spaces having a certain depth, therefore lying in the same layer, posses a certain

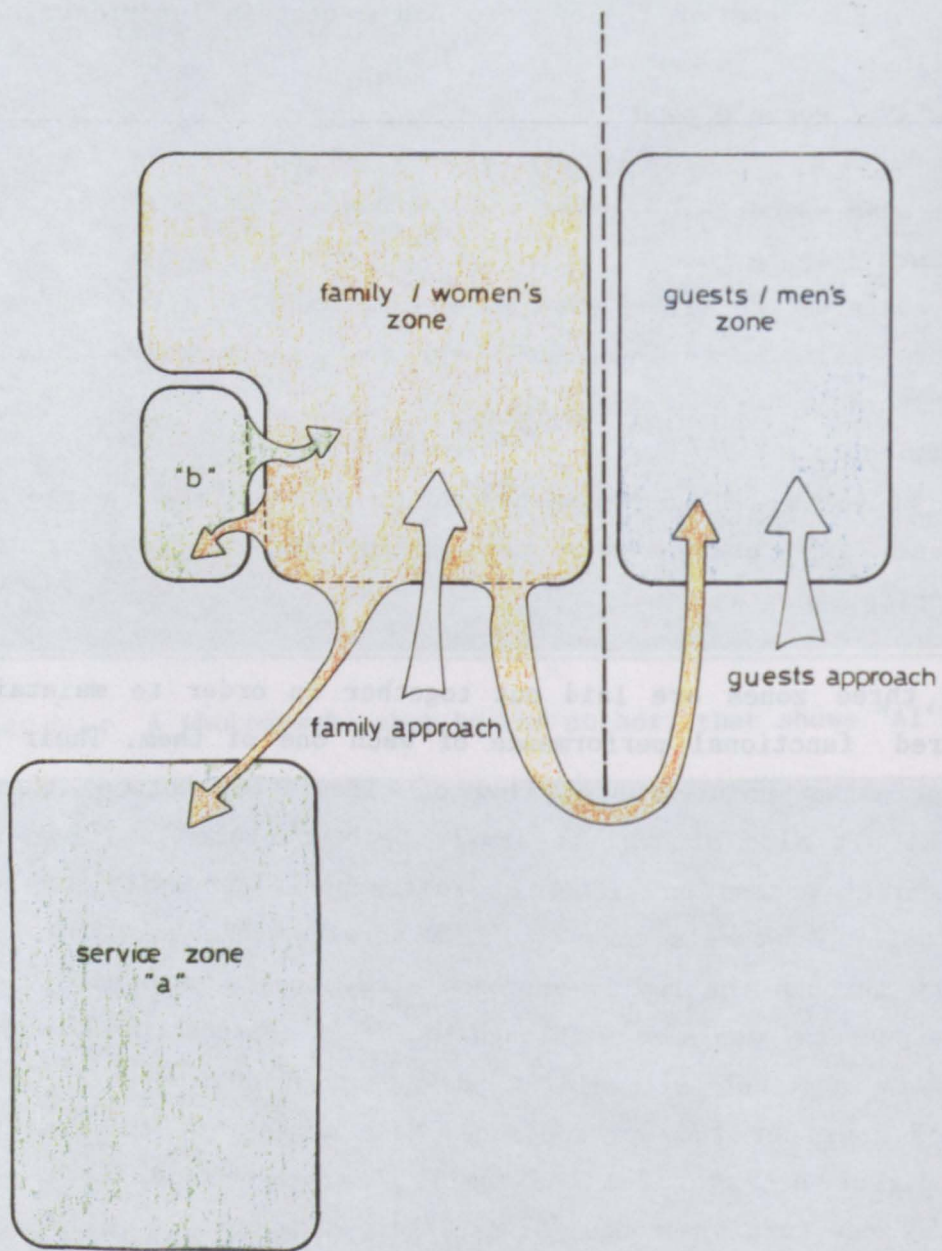

Fig. 8 : A diagram that shows the flow of circulation between the different zones of the house.

Key :



this arrow shows the direction of the main flow of circulation between the different zones of the house.

degree of permeability. The presentation and analysis of the house of "bait al'badu" leads to the fact that it is very shallow. A stranger can reach the deepest space in the house only by crossing either of the approach areas. The family living area and "al'majlis" have the same depth.

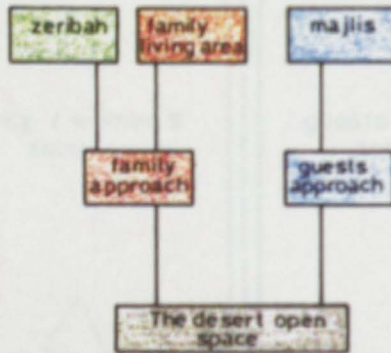
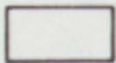

Fig. 9 : A map that shows the hierarchical spatial organisation of "bait al'badu".

Note : This map is based on the direct accessibility from one space to the other, and on the method of the justified gamma maps (4).

Key :



a space in the house



one step = a movement from one space to another

Figure 10 shows the main spaces of "bait al'badu". A graphic interpretation of the division of spaces in accordance with the different activities carried out in them is also shown. The actual area of spaces is neglected.

The spaces forming the three zones of "bait al'badu" are characterised by being multi-functional spaces. Most of the spaces, if not all, perform a number of different functions at different times of the day. For example: "al'majlis" (see Fig. 2 - men's side), where the space is used for both sitting and dining.



SPACE TITLE	ACTIVITIES CARRIED OUT IN THE SPACE	GRAPHIC INTERPRETATION
Al'Majlis	= GUEST RECEPTION = [sitting & dining]	
Family Living Area	= LIVING/BEDROOM • DRESSING ROOM • FOOD PREPARATION = [sleeping sitting dining] [changing and clothes store] [cooking area]	
Al'Zeribah	= FODDER • ANIMAL SHELTER	

Fig. 10 : A table that shows the different activities carried out in the different spaces of "bait al'badu", and their graphic interpretation.

Conclusion

The house of "bait al'badu" consists of three main zones which are:

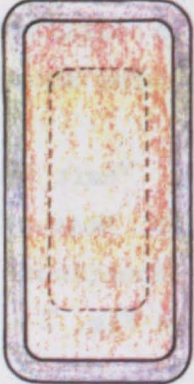
- family / women's zone
- guests / men's zone
- services zone

The layout of these zone maintains the required accessibility between them, without obstructing one circulation flow to the other.

Representation and analysis of the structure permeability of "bait al'badu" feature its main characteristic. That is being shallow and easily permeable to strangers. Each space of the house of "bait al'badu" performs more than one function.

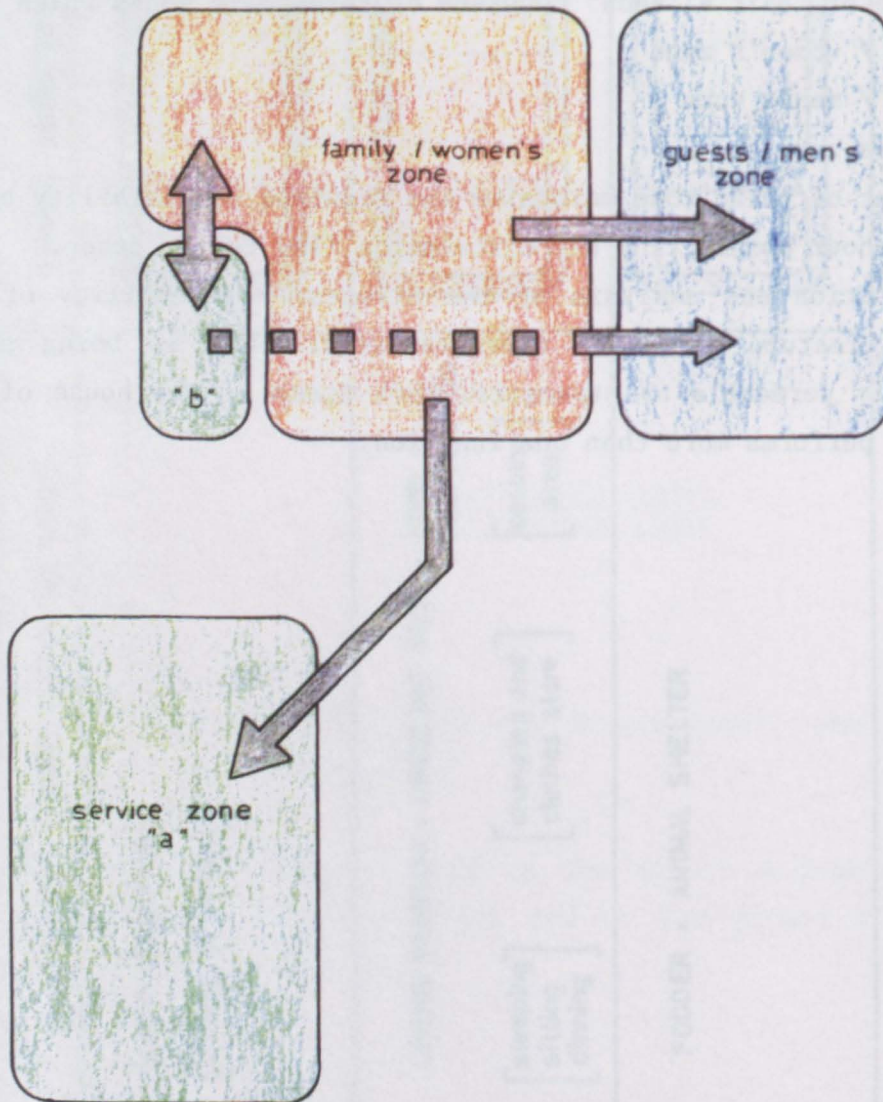

Fig. 11 : A diagram that shows communication degrees between the house different zones.

Key :

- ↔ mutual and dense
- single and frequent
- ■ → single and infrequent

Socio-cultural Aspect

The design of "bait al'badu" is a direct interpretation of the social behaviour patterns of its households. The socio-cultural background of the tribesmen induced a very important social value; Privacy. Communication allowed between different zones in the house is governed by the degree of privacy each one requires (see Fig. 11). Supplying the needed protection, from immediate visual & aural inspection, for each zone achieved privacy for each of their multi-functional spaces (see Fig. 12).

The design of "bait al'badu" is a direct transcription of the social behaviour patterns of its inhabitants. The socio-cultural background of the witnesses indicates a very important social value: privacy. Communication spaces between different rooms in the house is governed by the degree of privacy each one requires (see Fig. 11). Spatially the house is divided into two main areas: a central area for the family and a peripheral area for guests. The central area is divided into three main spaces: the family living area, the family approach, and the desert open space. The peripheral area is divided into two main spaces: the majlis and the guests approach. The diagram shows the types of communication between these spaces.

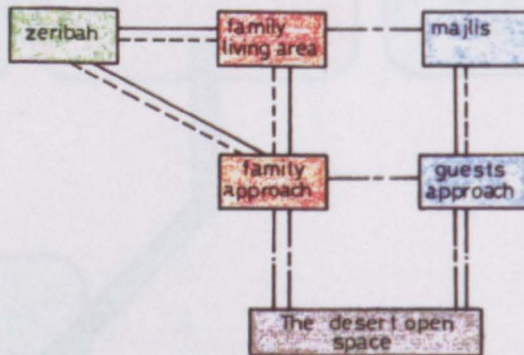

Fig. 12 : A map that shows the types of communication between different spaces of the house of "bait al'badu".

Note : This map is based on the immediate audio/visual inspection from any space on the next permeable one (5).

Key :

- a space in the house
- direct aural
- indirect aural
- direct visual
- indirect visual

Separation of zones

Separation between the three zones of the house was essential in order to maintain privacy inside the house. This was achieved by detaching a major part of the service zone from the family / women's zone and the guests / men's zone. The preceding two zones were separated by "al'qata", the dividing curtain wall which extends outside the house to divide the outdoor approach area into two (see Fig. 2). The location of each zone within the house is chosen carefully, thus maintaining high functional performance without interrupting each other's privacy. The service zone being located next to the family / women's zone allows easy access for the family members.

Al'Rowag

Al'Rowag is the area surrounding the house of "bait al'badu", which lies between the tent curtain walls and the tent stakes. This area protects the inside of the house from being directly inspected, weather aurally or visually.

Conclusion

The separation of zones in the house of "bait al'badu", achieves the privacy needed for each one. Immediate audio / visual inspection of households on others is prevented by respecting the surrounding territory of each house. This territory is defined by the half of a walking distance of about 20-25 minutes between each two houses in any direction.

Technical Aspect

The process of making the house of "bait al'badu"- "house of hair", is carried out utilising natural materials. Local beduins have their own traditional method of making "bait al'badu". A detailed study of the utilised materials and the applied method of making "bait al'badu" will be carried out.

The utilised materials

The main utilised natural materials in making the "house of hair" are the following:

- 1) Hair
- 2) Wood
- 3) Leather

1) Hair

It is pure goat hair or a mixture of goat hair and sheep wool, or even sometimes, a mixture of goat hair and camel wool. The mixture is woven together to make tent's, "house of hair", cloth breadths (see Ecological Cond.).

2) Wood

Wood is the trunks of "al'ghaf" and/or "al'sidr" local wild trees which grows in the desert (see Ecological cond.). These tree trunks are used as poles to set up the tent "house of hair", "al'talal" and "al'zeribah".

3) Leather

It is goat or sheep skin. It is used in making the tent fastenres (see Ecological Cond.).

The applied method of making the "house of hair"

The goat hair is woven to make the cloth material of the tent of the "house of hair". The tent cloth is woven in breadths of about

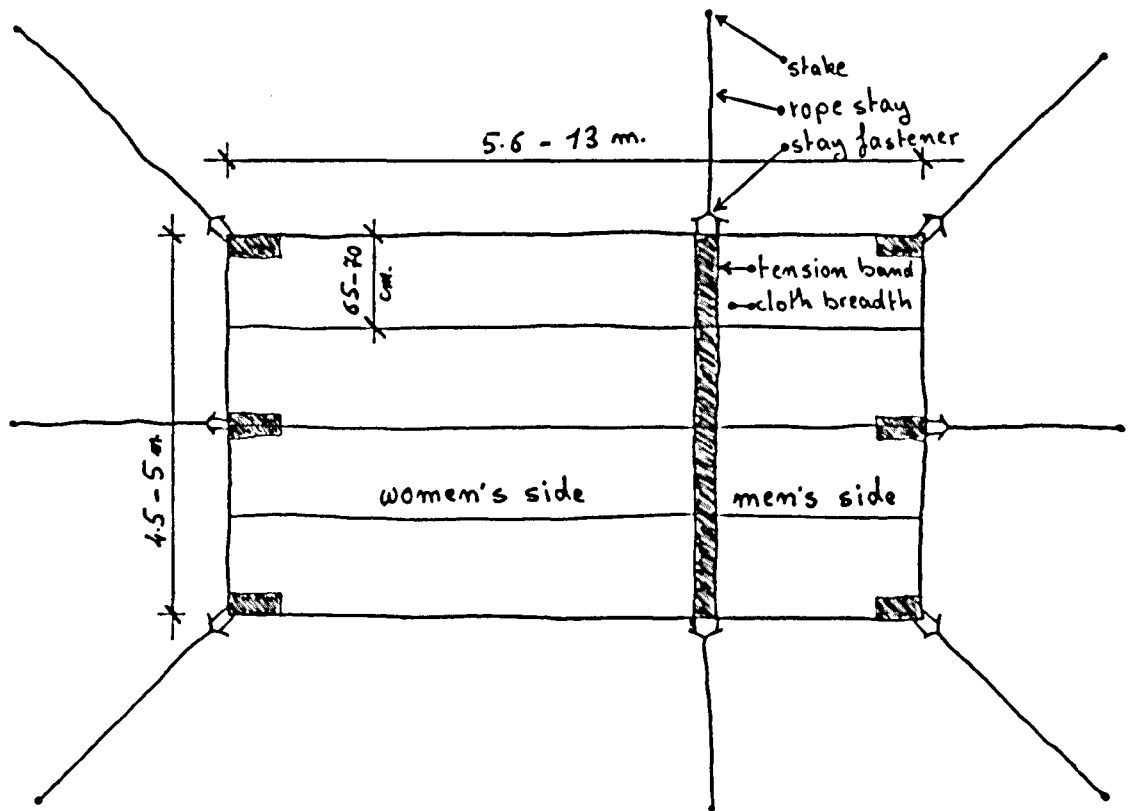

Fig. 13 : A sketch that shows the tent cloth (6).

65 - 70 centimetres wide, and 5.6-13 metres long. The cloth breadths are sewn together to form the tent cloth (see Fig. 13). Tension bands are sewn across the breadths, their number depends on the relative size of the tent. Each band is supported by three poles. A centre pole of about 2.1 metres, fixed to the tent roof by wooden shoe sewed to the roof lining. This roof lining is locally called "al'triga" (see Fig. 14). The two other poles are posted on either sides of the central one in alignment with the tension band. At the end of each tension band there is a stay fastener and a rope stay. The stay fasteners, made of wood and leather, are of various types (see Fig. 15). The rope stays are of about 30 metres long or more. This length helps to absorb the shock of sudden winds, where it transfers the pull to be nearly perpendicular on the stakes. Thus the stakes are not easy to be pulled out of the sand (1).

Setting up the tent

The chosen area is cleared of stones and shrubs, if there is any, and made as level as possible. The tent is then unrolled and spread over the prepared surface. The ropes are pulled out and staked. To anchor the tent to the ground, the ropes are tied around a bush and burried in the sand. Then one of the corner poles is pushed up in place, next, the poles along one side followed by the centre poles. When all poles are in place and the roof is aloft, the curtain walls are pined in place (see Fig. 16). The bottom of the curtain walls is burried in the sand or covered with bushes & rocks to prevent reptiles from entering inside the tent.

Conclusion

The tent of the "house of hair" is made of natural materials. These materials are found in the local environment. The tent of the "house of hair" is characterised by the reduced number of tension bands to the minimum required. Rope stays are long. The minimal use of wood resulted in its light weight, and the easiness of its transportation.

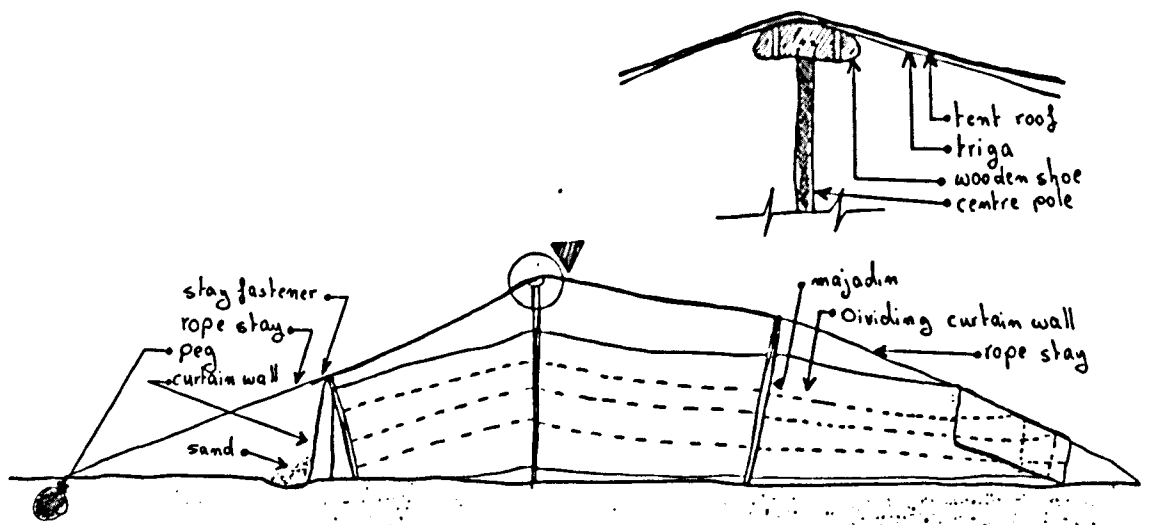

Fig. 14 : A sketch that shows a transversal section passing through the tent, and parallel to the dividing curtain wall (7).

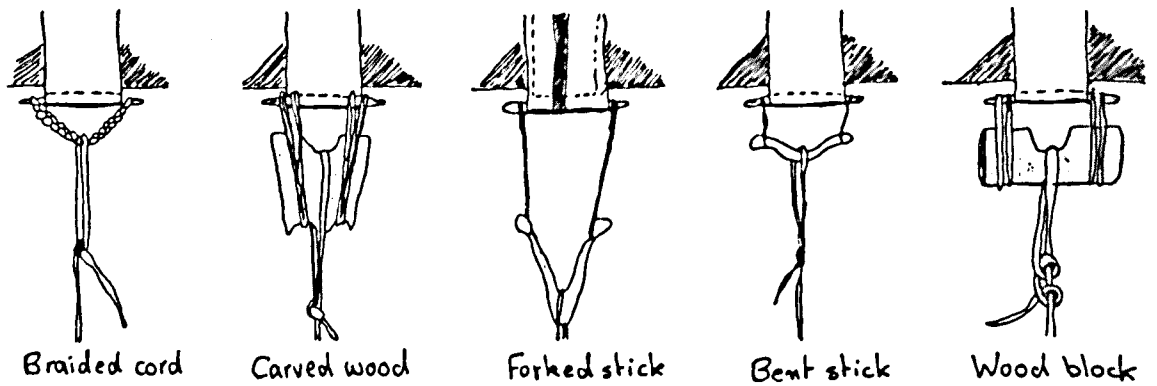

Fig. 15 : A sketch that shows various types of stay fasteners (7).

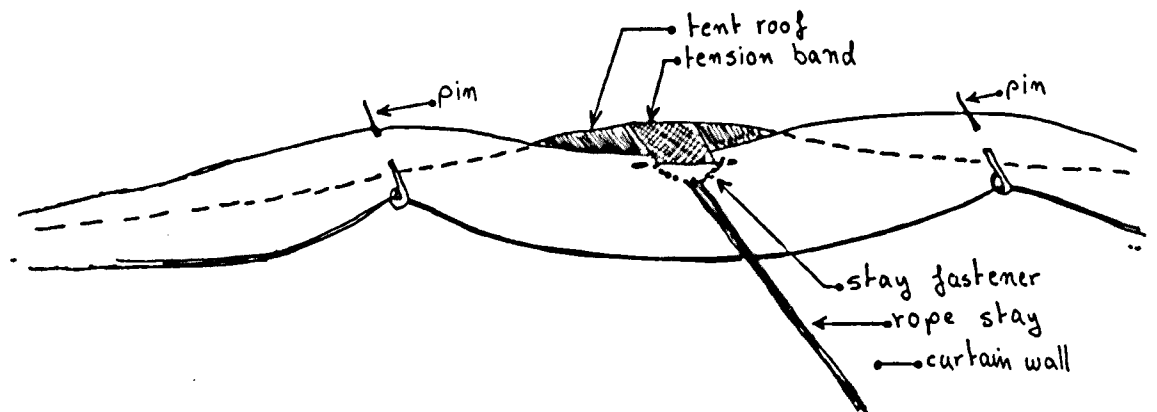

Fig. 16 : A sketch that shows the curtain walls pinned to the tent roof (7).

Environmental Aspect

In spite of the severe environmental conditions of the desert of Abu Dhabi, the tent of the "house of hair" successfully adapts to its local environment. In the make and the setting up of the tent the beduins took into consideration the following:

- 1) The shape and the orientation of the tent.
- 2) The natural ventilation.
- 3) Sun and sand protection.

1) The shape and orientation of the tent

The shape

The tent of the "house of hair" is rectangular in shape (see Fig. 2). The tent roof is flattened in order to reduce the surface area exposed to the sun, and so that the winds can not take hold of it and blow it away.

The orientation

The tent is always pitched to face east to south-east (see Fig. 17). This particular orientation provides a considerable shaded area in front of the tent. It also prevents the tent from being blown up by the north-western prevailing winds. This orientation allows the households to benefit from the morning sun, and to avoid the afternoon sun.

2) The natural ventilation

The natural ventilation of the tent of the "house of hair" was maintained through its orientation, opening sizes and their location (see Fig. 18). If the tent is set up near by the coast or on one of the islands, natural ventilation is maintained as shown in figure 18. The narrow openings are located on the backside between the curtain walls and the roof of the tent, facing the prevailing winds. The wide openings are located on the front side of the tent. The air inlets being narrower than the outlets accelerate the air entering the tent. Thus reducing

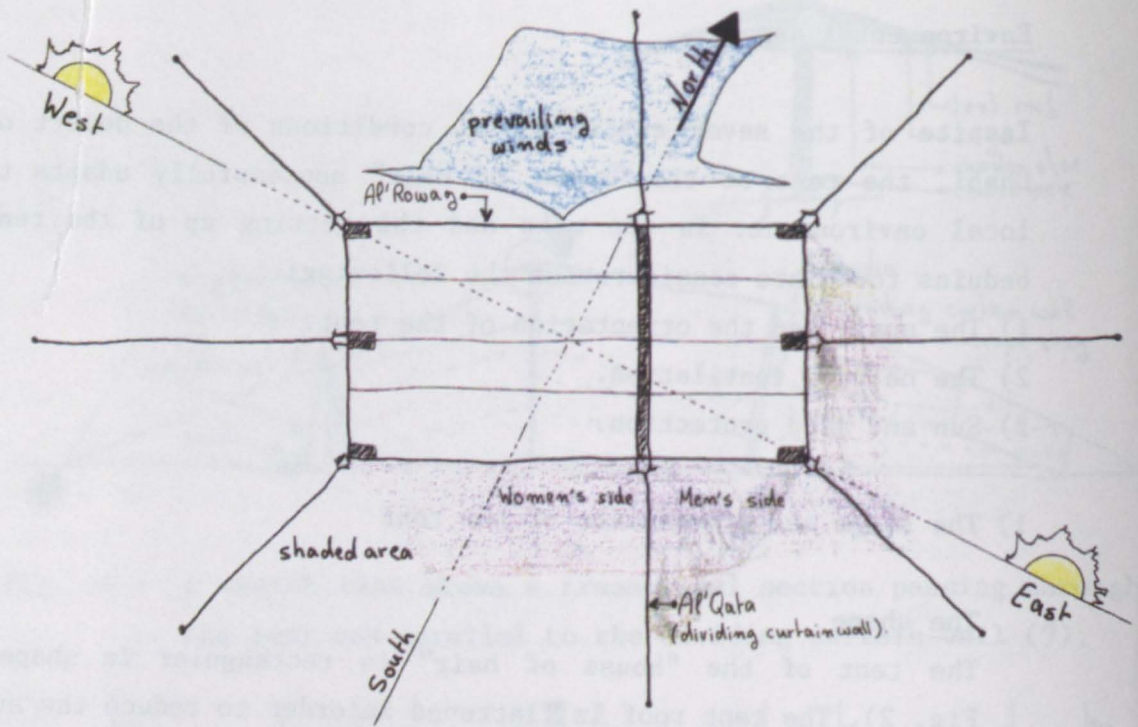

Fig. 17 : A sketch that shows the orientation of the tent of the "house of hair".

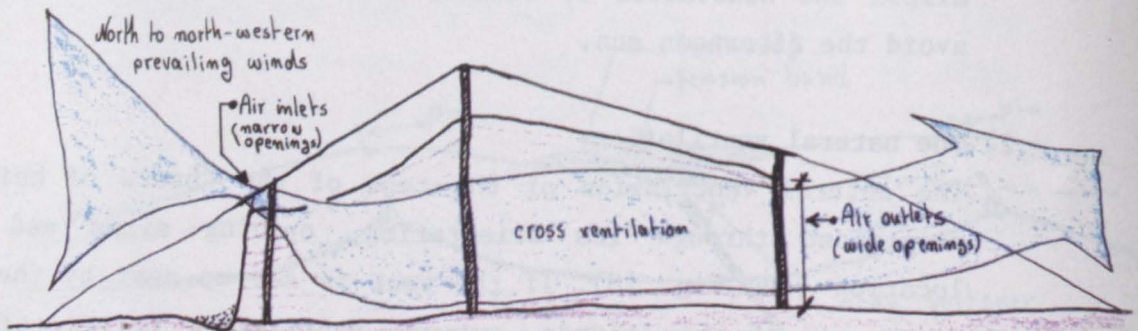

Fig. 18 : A sketch that shows the natural ventilation of the tent of the "house of hair" when set up near by the coast or on one of the islands.

its temperature and maintaining continuous natural ventilation. If the tent is set up on the main land, the narrow openings are closed. Therefore, preventing hot dry air from entering the tent.

3) Sun and sand protection

The tissue of the tent roof and the curtain walls is impermeable to both sun and sand. The roof projecting over the curtain walls of the tent, prevents the sun rays from entering through the narrow openings between them. A piece of sack cloth is sewed to the bottom of the curtain walls all around the tent. It is buried in the sand or covered with bushes and rocks to prevent crawling sand from entering inside the tent.

Conclusion

The tent of the "house of hair" is a remarkable example of the adaptation to the severe environmental conditions in Abu Dhabi. The rectangular layout, south-eastern orientation, and maintaining natural ventilation are reasons for successful adaptation to the local environment.

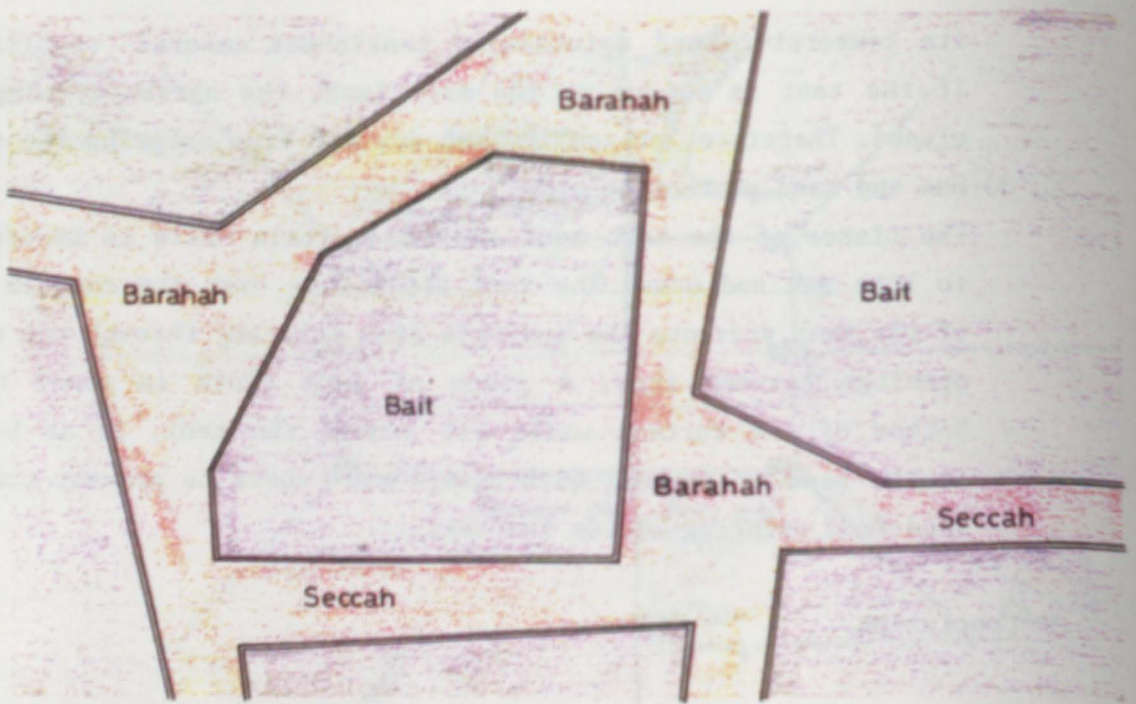

Fig.19a: A sketch showing how "Biute al Sahel" were laid out.

Key :



Seccah & Barahah



Bait

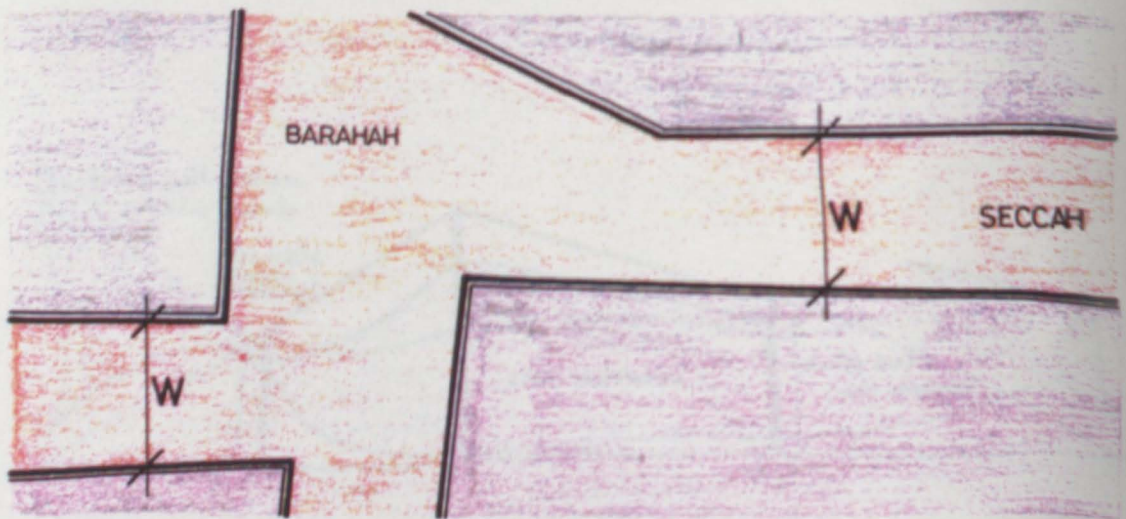

Fig.19b: A sketch showing the width of a "Seccah".

Key:

W = The total width of a "seccah", 3-4 people side by side,
(about 2.00 - 2.50 metres).

2.1.2 Biute al'Hadar

Biute al'Hadar, the houses of the local people living either in rural or in urban areas, are of two types. These two types are:

- a) Biute al'Sahel
- b) Biute al'Burr

a) Biute al'Sahel

Biute al'Sahel are the traditional houses of the local people, that are built on Abu Dhabi's coast or on islands belonging to Abu Dhabi. They are built close to each other forming groups of houses, where a group of houses built on either side of a wide street is called "Fereej". Most, if not all, houses forming a "fereej" are of irregular forms (see Fig 19a). This irregularity of forms generates a complex pattern of streets visually impermeable to strangers, and help channeling air between the houses. This tendency towards creating self-contained groups of houses resulted in a chain of piazzas called "Barayeh" (plural of "Barahah"). They are points of social contacts between neighbours, and are commonly used as playgrounds for children and for wedding parties. These "barayeh" are linked together by a network of divergent passage ways called "Secake" (plural of "Seccah"). They are narrow in width (see Fig 19b), allowing a maximum number of 3-4 people to walk side-by-side. Biute al'Sahel consist of two main types of houses, which are :

- a')The palm-frond tents; locally called "Khaimat al'Saaf".
- a'') The coral-block houses; locally called "Bait al'Sahel".

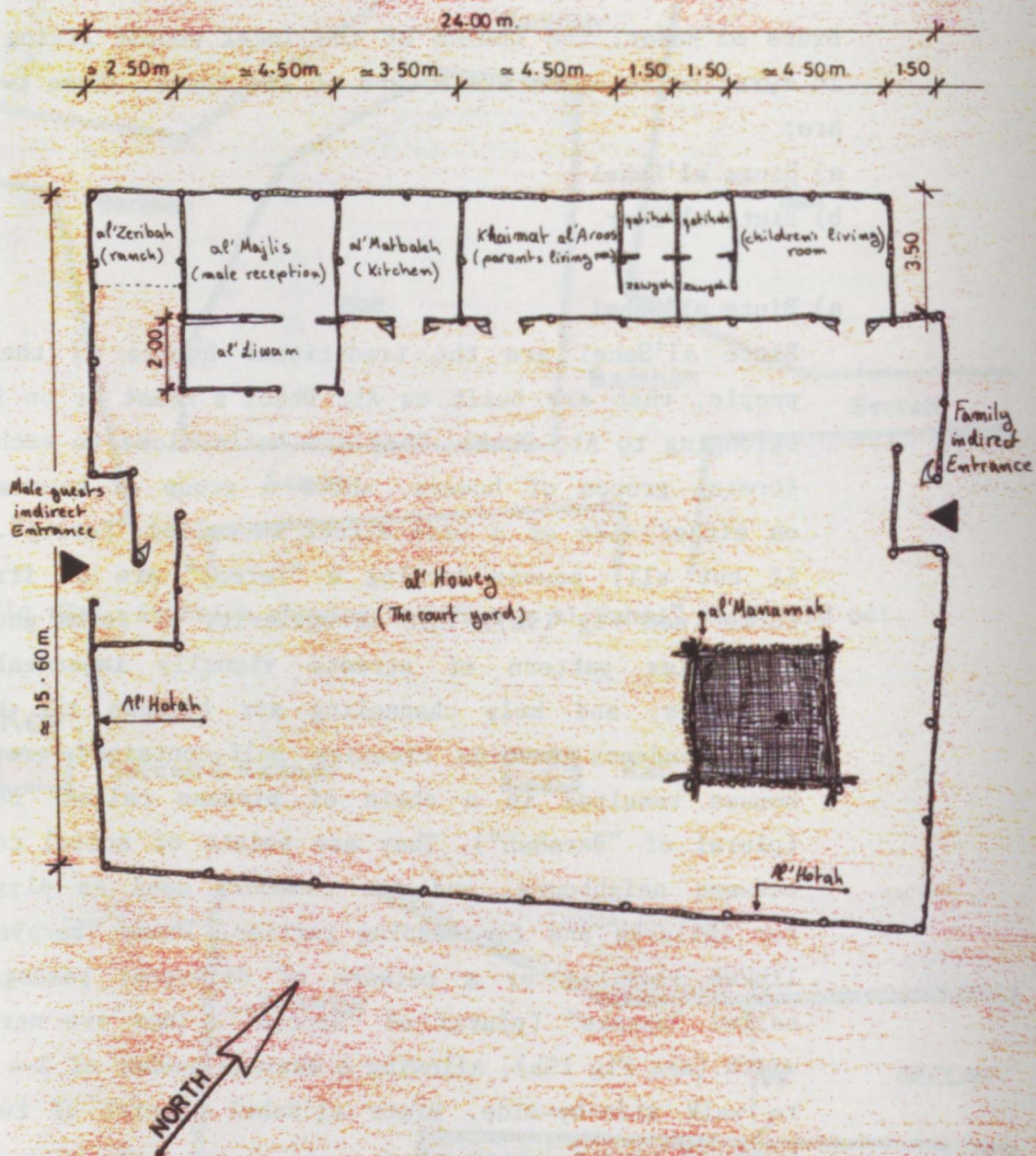

Fig. 20 : An example for "Khaimat al'Saaf" - the palm-frond tent.

Note : This drawing is not to scale; dimensions shown are approximated.

a') Khaimat al'Saaf

Khaimat al'Saaf is the local name given to the palm-frond house. The word "Khaimat" means the tent of, the plural is "Kheyam". The word "al'Saaf" means the palm fronds. Thus "Kheyam al'Saaf" means the palm-frond tents. It is the most common type of house built in Abu Dhabi, both on the coast and on the main land. An example for one of the "Khaimat al'Saaf" is shown in figure 19. Khaimat al'Saaf is generally divided into three main zones (see Fig. 21), which are:

- 1) Family / women's zone
- 2) Guests / men's zone
- 3) Services zone

The three zones are built next to each other on one side of a courtyard, locally called "Howey". The area of the "Howey" is confined by the house elements on one side, and the bordering boundary walls locally called "Hotah" (see Fig. 20). The house has got two entrances, a family entrance and a guests entrance. The two entrances are located opposite to each other across the court yard.

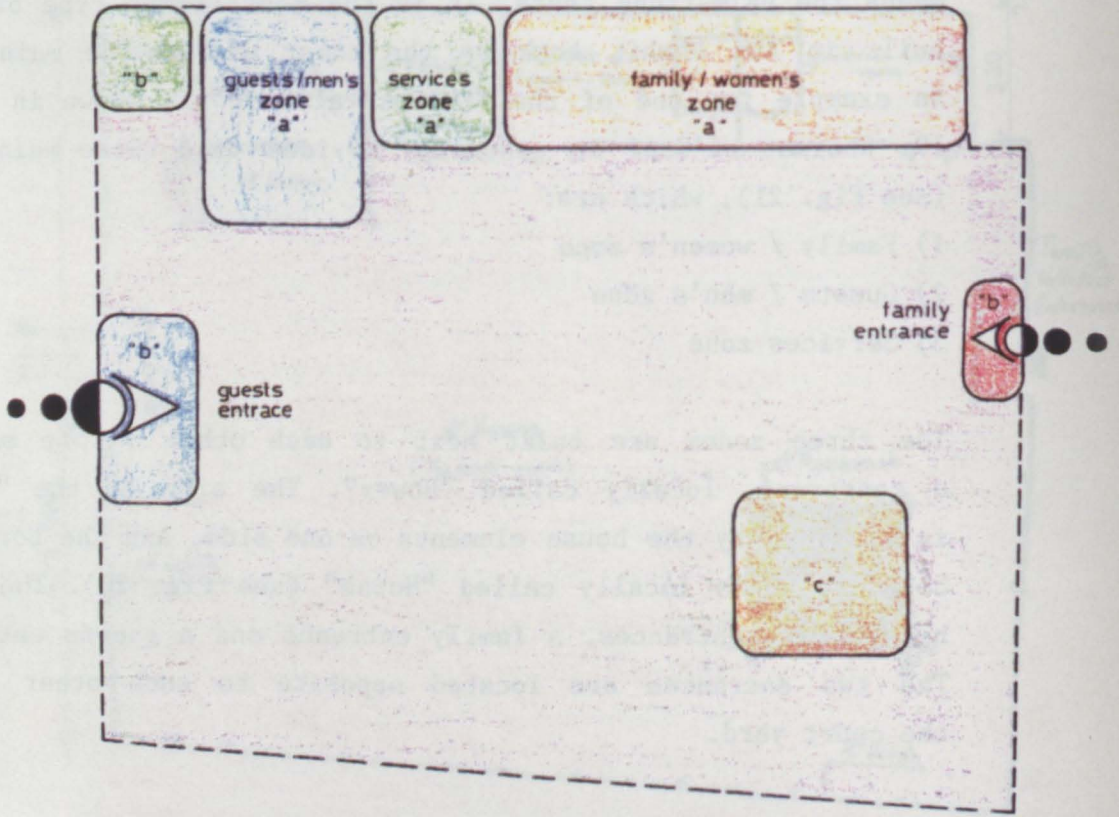

Fig. 21 : A diagram that shows the different zones of "Khaimat al'Saaf".

Each zone of this type of house, "Khaimat al'Saaf", consists of one or a number of multi-functional spaces, which are as follow:

1) Family / women's zone

The family zone consists of the family living rooms. The parents living room is locally called "Khaimat al'Aroos", which means the bride's tent. The family living rooms are of rectangular shapes, with their breadths facing the courtyard. The number of the family living rooms varies depending on the family size. Each of the family living rooms consists of three confined areas (see Fig. 20): a main area for sitting, sleeping, dinning and coffee making; a dressing area called "Zawiah"; a bathing and ablution area called "Qatihah". The family living rooms are directly accessible from the courtyard through a palm-frond double door (see Fig. 22). In hot summer nights the family sleeps outdoor on a palm-frond platform, locally called "Al'Manamah" which means the place to sleep. "Al'Manamah" is located in the courtyard area facing the family living rooms. It is raised about one metre above the ground level (see Fig. 23).

2) Guests / men's zone

The guests / men's zone consists of two main confined rooms. The first is used as a sitting and dining room for male guests. It is called "Al'Majlis". It has a rectangular shape. It is directly accessible through the second confined room, locally called "Al'Liwan". It has also a rectangular shape and it is directly accessible from the courtyard. It is used as "Al'Majlis" in hot summer days. A wind tower, locally called "Al'Barjeel", is constructed on its roof to provide cool air (see Fig. 24).

3) Services zone

The services zone consists of two main spaces, which are:

- a kitchen called "Matbakh"
- a ranch called "Zeribah"

The Matbakh

The "Matbakh" has a rectangular shape. It is located between the parents living room and "al'Majlis". It consists of one area used for cooking, food preparation and storage.

The Zeribah

The "Zeribah" consists of one confined shaded area located between "al'Majlis" and the boundary wall. It is used for keeping goats and sheep, where it has in one of its corners a small fodder store.

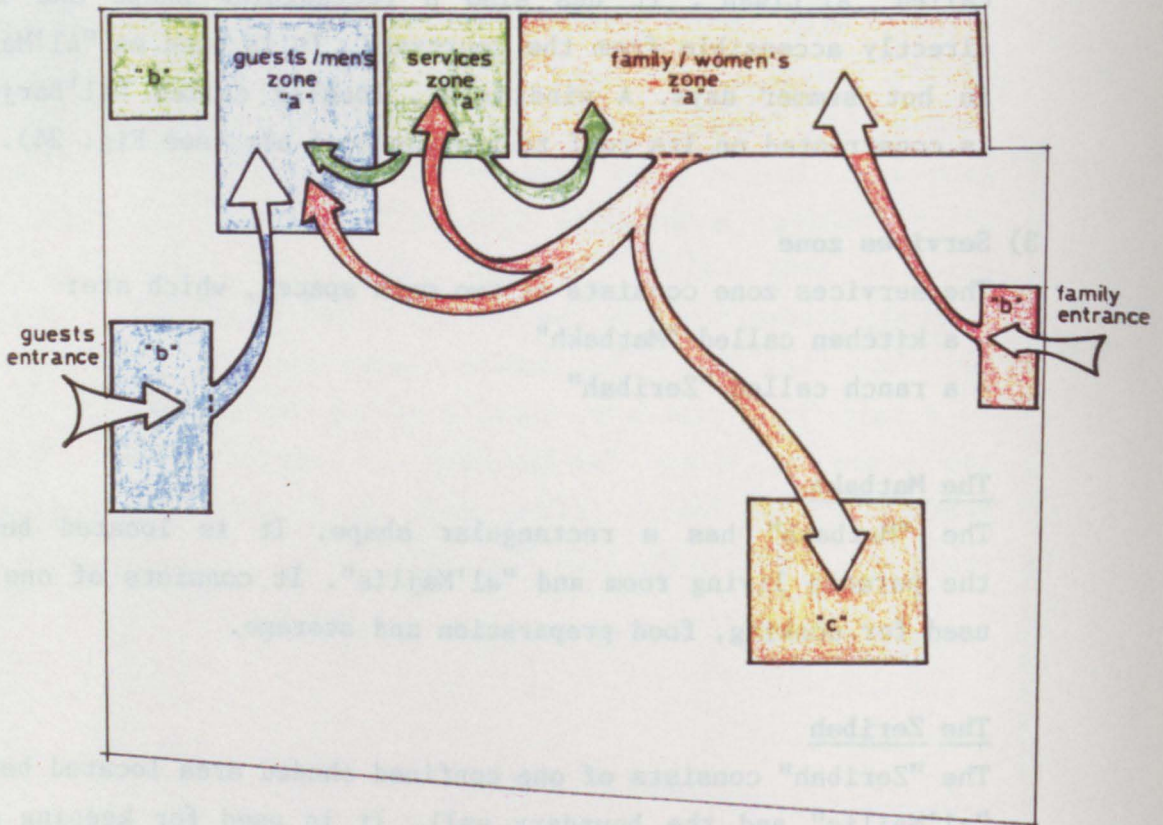
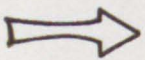

Fig.25 : A diagram that shows the flow of circulation between the different zones of the house.

Key :



this arrow shows the direction of the main flow of circulation between the different zones of the house.

Functional Aspect

The palm-frond tent, "Khaimat al'Saaf", is divided into three main zones (see Fig. 21). Each one of these zones has a certain function. They are as follow:

1) **Family / women's zone**

It contains the family living rooms where each member of the family has his / her own self contained room.

2) **Guests / men's zone**

It contains the male guests reception room, "al'Majlis", and the summer reception room, "al'Liwan".

3) **Services zone**

It contains the two basic services which are required to assist life in the house, which are: a kitchen, a small ranch.

These three zones are laid out together in order to maintain the required functional performance of each one (see Fig. 25). The layout of "Khaimat al'Saaf" shows two separate indirect entrances, a family entrance and a guests entrance. Each entrance is located on its corresponding side of the boundary wall.

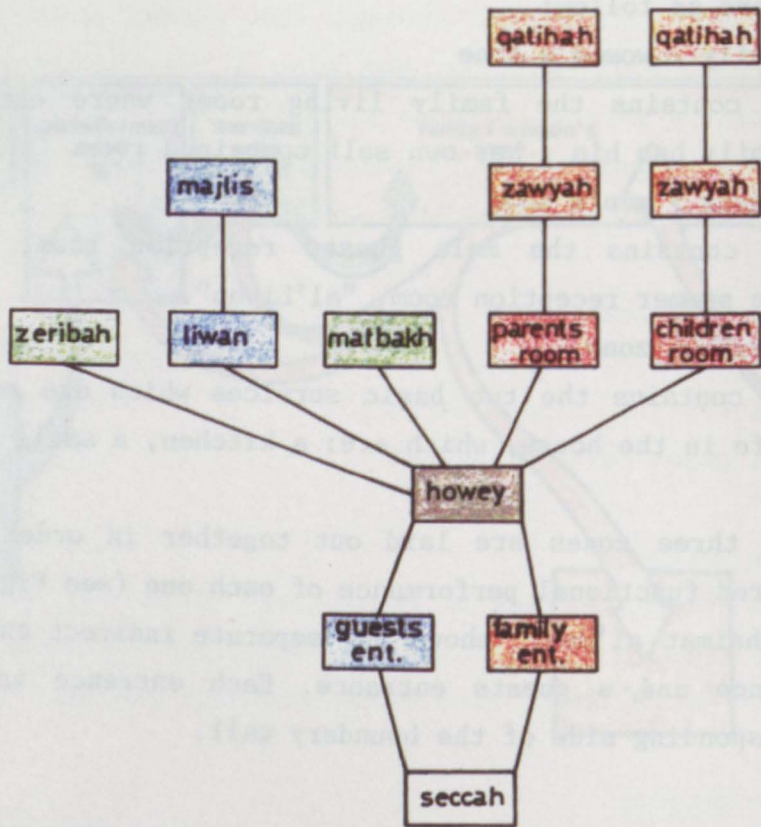
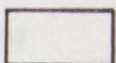

Fig.26 : A map that shows the hierarchical spatial organisation of "Khaimat al'Saaf".

Note : This map is based on the direct accessibility from one space to the other, and on the method of the justified gamma maps (4).

Key :



a space in the house



one step = a movement from one space to another

In figure 26, "Khaimat al'Saaf" is divided into a number of layers based on the equal number of movements leading to different spaces among it. This number of movements is in relation to the outdoor public space. The more number of movements needed to reach a certain space inside "Khaimat al'Saaf", the deeper this space is. Spaces having a certain depth, therefore lying in the same layer, possess a certain degree of permeability. Beginning from the outdoor public space the penetration of the house spatial pattern is controlled. That is by providing the house with two functional links to the outdoor public space. Each link leads to a series of spaces which have an increasing depth. The increase in depth of each space is governed by the degree of privacy it requires. The increasing depth of the various functional spaces of "Khaimat al'Saaf", resulted in its sequential spatial organisation.

Figure 27(a,b) shows the main spaces of "Khaimat al'Saaf". A graphic interpretation of the division of spaces in accordance with the different activities carried out in them is also shown. The actual areas of spaces are neglected.

The various spaces forming the three zones of "Khaimat al'Saaf" are characterised by being multi-functional spaces. Most of the spaces, if not all, perform a number of different functions at different times of the day. For example: the parents living room, "Khaimat al'Aroos" (see Fig. 20), where it is used for sitting, sleeping, dinning and coffee making.

SPACE TITLE	ACTIVITIES CARRIED OUT IN THE SPACE	GRAPHIC INTERPRETATION
Khaimat al' Aroos	= LIVING/ BEDROOM • DRESSING ROOM • BATHROOM [sleeping , sitting & dining] [changing room, clothes store] [bathing & ablution]	
Al' Matbakh	= KITCHEN • STORE [food preparation cooking] [food storage]	
Al' Majlis	= GUEST RECEPTION [sitting & dining]	
Al' Howey	= COURT YARD (protected open area for family gathering and celebrations, circulation, children playground & gardening.)	

Fig. 27(a) : A table that shows the different activities carried out in the different spaces of "Khaimat al'Saaf", and their graphic interpretation.

Fig. 27(b)

SPACE TITLE	ACTIVITIES CARRIED OUT IN THE SPACE	GRAPHIC INTERPRETATION
Al'Zeribah	= ANIMAL SHELTER + FODDER	

Conclusion

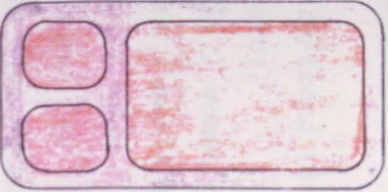
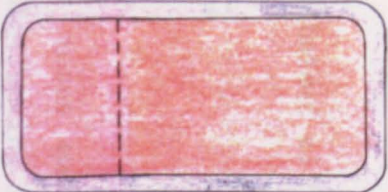
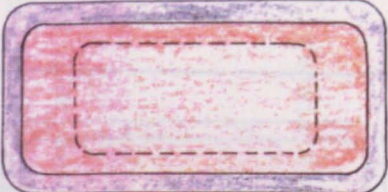
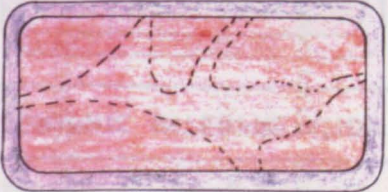
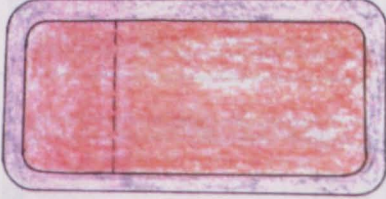
The palm-frond tent, "Khaimat al'Saaf", consists of three main zones, which are:

- family / women's zone
- guests / men's zone
- services zone

The layout of these zones maintains the required accessibility between them without obstructing one circulation flow from the other. Khaimat al'Saaf has a hierarchical organisation of spaces, which performs a variety of functions at different times of the day.

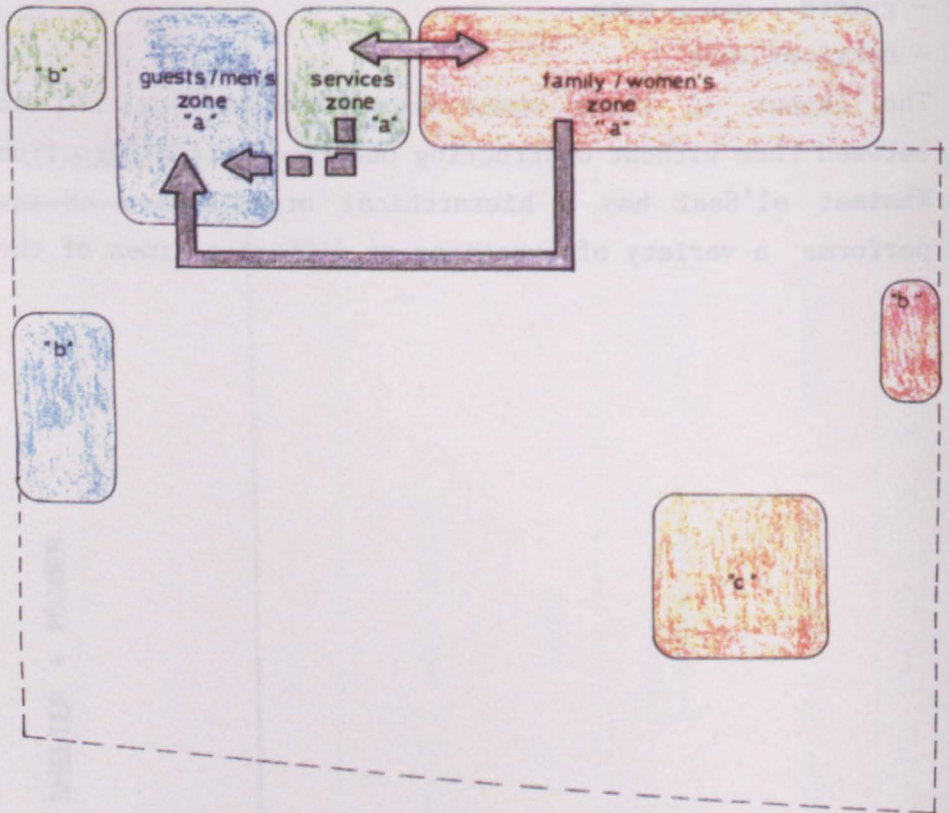

Fig. 28 : A diagram that shows communication degrees between the house different zones.

Key :

- ↔ mutual and dense
- single and frequent
- □ → single and infrequent

Socio-cultural Aspect

The design of "Khaimat al'Saaf" is a direct interpretation of the social behaviour patterns of its households, where the social value of privacy is of great importance. Communication between different zones of "Khaimat al'Saaf" is governed by the degree of privacy each zone requires (see Fig. 28). Supplying the needed protection, from immediate visual & aural inspection, for each zone achieved privacy for each of their multi-functional spaces (see Fig. 29).

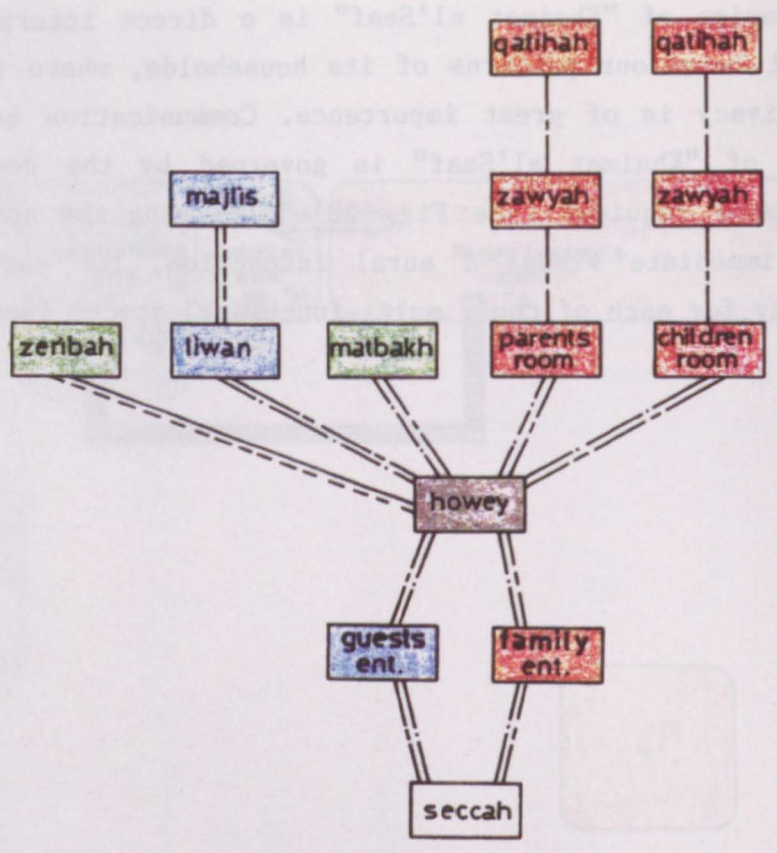

Fig. 29 : A map that shows the types of communication between different spaces of "Khaimat al'Saaf".

Note : This map is based on the immediate audio/visual inspection from any space on the next permeable one (5).

Key :

- a space in the house
- direct aural
- indirect aural
- direct visual
- .-.-.- indirect visual

A courtyard house

The components of "Khaimat al'Saaf" overlooking a courtyard, allowed the family to have a private outdoor space within the house area. While family living rooms have doors overlooking only the courtyard, ventilation openings are located at the top of the walls overlooking the outside.

Separation of zones

Separation between the three zones of the house was essential in order to maintain privacy. This was achieved by placing a major part of the services zone between the family / women's zone, and the guests / men's zone. Thus allowing easy access to the services zone for the family members, without passing through the guest / men's zone.

Separate indirect entrances

Supplying the house with two indirect entrances, a family entrance and a guests entrance, achieves privacy for the family members. Both entrances being indirect protect the courtyard from outside visual inspection.

The boundary wall

The boundary wall "al'Hotah", having sufficient height, prevents direct visual inspection from outside the house. Thus protecting the privacy of the households outdoor space, and defining their territory.

Conclusion

The palm-frond tent, "Khaimat al'Saaf", provides the households with the privacy needed to carry out their every day life. The location of each space in "Khaimat al'Saaf" is a direct result to the degree of privacy it requires.

Technical Aspect

The process of building "Khaimat al'Saaf" is carried out utilising natural building materials. A study of these natural building materials and the applied method of building "Khaimat al'Saaf" will be carried out.

The utilised materials

The main utilised natural materials in building "Khaimat al'Saaf" are:

- 1) Wood
- 2) Al'Toor
- 3) Leaf al'Nakhl
- 4) Al'Haseer

1) Wood

Wood is the dead palm-tree trunks. They are used as poles and beams in building the framework of the house (see Ecological Cond.).

2) Al'Toor

Al'Toor is the local name given to the palm-tree fronds. They are used in building the walls and the roofs of the house (see Ecological Cond.).

3) Leaf al'Nakhl

Leaf al'Nakhl is the local name given to the fibrous bark that grows at the bottom of the palm-tree. It is used as a thermal insulating material within the roof layers. It is also used in weaving ropes used in assembling the house elements together (see Ecological Cond.).

4) Al'Haseer

Al'Haseer is the local name given to the mats made out of interweaved branches of "Al'Mangaroaf" (see Ecological Cond.).

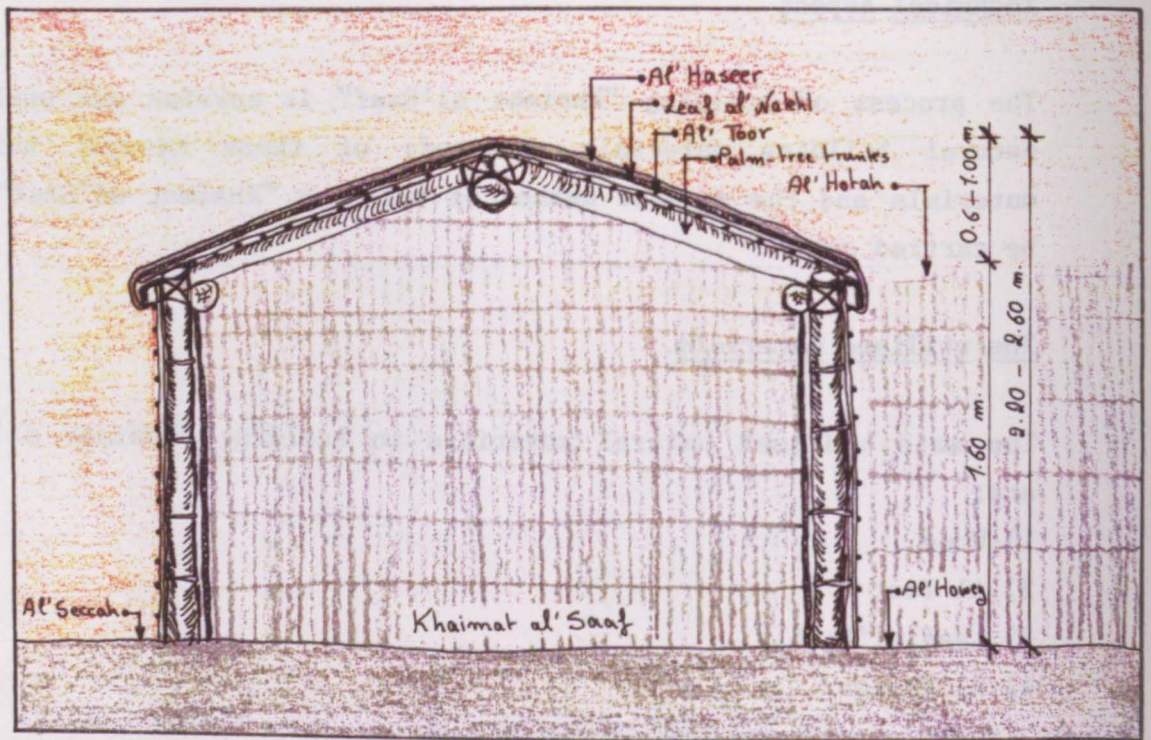

Fig. 30 : A sketch that shows a transversal section passing through "Khaimat al'Saaf".

The applied method in building "Khaimat al'Saaf"

The chosen piece of land, on which the house will be built, is cleared from stones and shrubs and made as level as possible. The framework made of dead palm-tree trunks is then constructed. Then poles of palm-tree trunks are fixed to the ground, following the land order, at intervals of about two metres. The palm-tree fronds, stripped from their leaves and spikes, are then laid together in order on the ground. Then they are bound together, with three or four lines of ropes, into mats. These mats form the walls, the roofs and the boundary walls of the house. Mats forming the walls facing prevailing winds are reinforced by tying further palm-tree fronds to them. They are tied in rows at right angles to the original ones. When the mats are ready, they are then lifted off the ground by a group of men and fixed to the vertical poles. After the roof mats are fixed in their place, a layer of fibrous bark "Leaf al'Nakh1" is added to the roof layers. Al'Haseer forming the final roof layer, is then laid down to cover the two preceding layers and tied with ropes to the roof mats (see Fig 30). The roof carrying the wind tower, "Al'Barjeel", is always flat where other roofs are slightly pitched. The wind tower is raised on four wooden poles. It is roofed with a mat similar to these of the house roofs. The wooden poles are linked together across the roof opening by four textile sheets (see Fig. 24).

Conclusion

"Khaimat al'Saaf" or the palm-frond tent, as they call it locally, is built entirely with natural building materials. These materials are found in the local environment of Abu Dhabi. The palm-frond tents are quick to erect and easy to move.

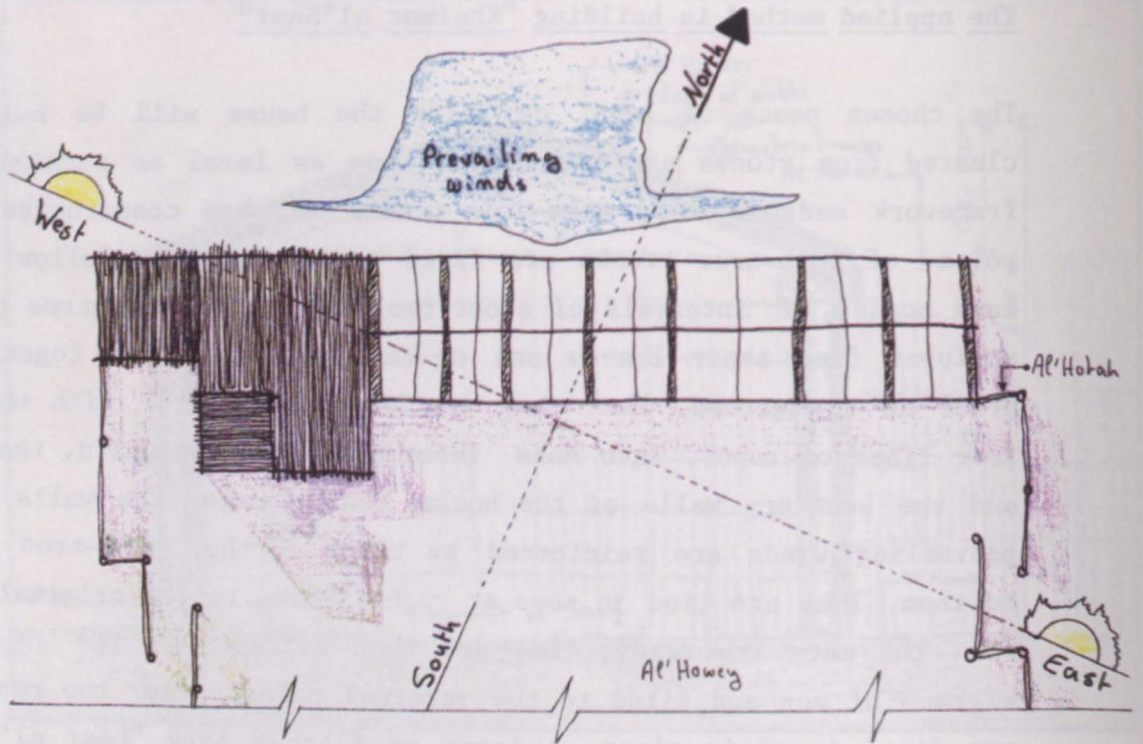

Fig. 31 : A sketch that shows the orientation of the palm-frond tent.

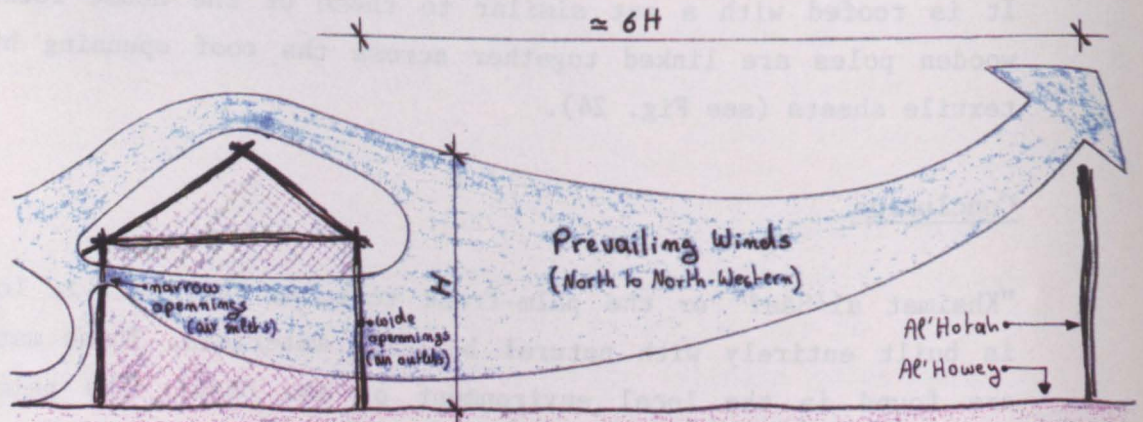

Fig. 32 : A sketch that shows the natural cross ventilation of the palm-frond tent.

Environmental Aspect

In spite of the severe environmental conditions of Abu Dhabi's coastal areas and main land, the palm-frond tent adapts efficiently to the local environmental conditions. In the process of designing and building the palm-frond tent, "Khaimat al'Saaf", the local people took into consideration the following:

- 1) The shape and the orientation of the tent.
- 2) The natural cross ventilation.
- 3) The sun and sand protection.

1) The shape and the orientation of the tent

The shape

The palm-frond tent, "Khaimat al'Saaf", has a rectangular shape (see Fig. 20). The roof of the tent is slightly pitched, so that the winds can not take hold of it and blow it away. This also secures a smooth air flow over the roof level.

The orientation

The palm-frond tent is always built to face east to south-east (see Fig. 31). This particular orientation provides a considerable shaded area in front of the palm-frond tent. It allows the households to benefit from the morning sun, and to avoid the afternoon sun.

2) The natural cross ventilation

Natural cross ventilation of the palm-frond tent is maintained through its orientation, opening sizes and location, and the wind tower. Narrow openings are located in the backside walls facing the prevailing winds (see Fig. 32). The wide openings, doors, are located on the opposite sides across the rooms. The air inlets being narrower than the air outlets accelerates the air entering the rooms. Thus reducing its temperature and maintaining continuous natural cross ventilation. The wind tower

maintains natural ventilation in the hot and humid summer times. Palm-frond tents built on the main land of Abu Dhabi do not have wind towers. The wind tower helps releasing the hot air inside the tent. It generates a cold draft through it and into the interior of the room. It also collects the cool summer winds from any direction they might blow and drives them inside the room. A more detailed study of the wind tower will be carried out in the example of the coral-block houses.

3) The sun and sand protection

The openings exposed to the sun most of the time are narrow and many. Therefore supplying sufficient natural lighting, and filtering the sun rays entering the tent. The roof layers containing "Leaf al'Nakhl" provides sufficient thermal insulation. The tent walls mats prevent sand filtration to the interior. The distance between the tent components and the boundary wall, across the courtyard, does not allow sand vortices to take place. Thus channelling the air inside the courtyard without steering up the sand.

Conclusion

The palm-frond tent, "Khaimat al'Saaf", provides very comfortable living conditions. It adapts to both hot/humid & hot/dry climates.

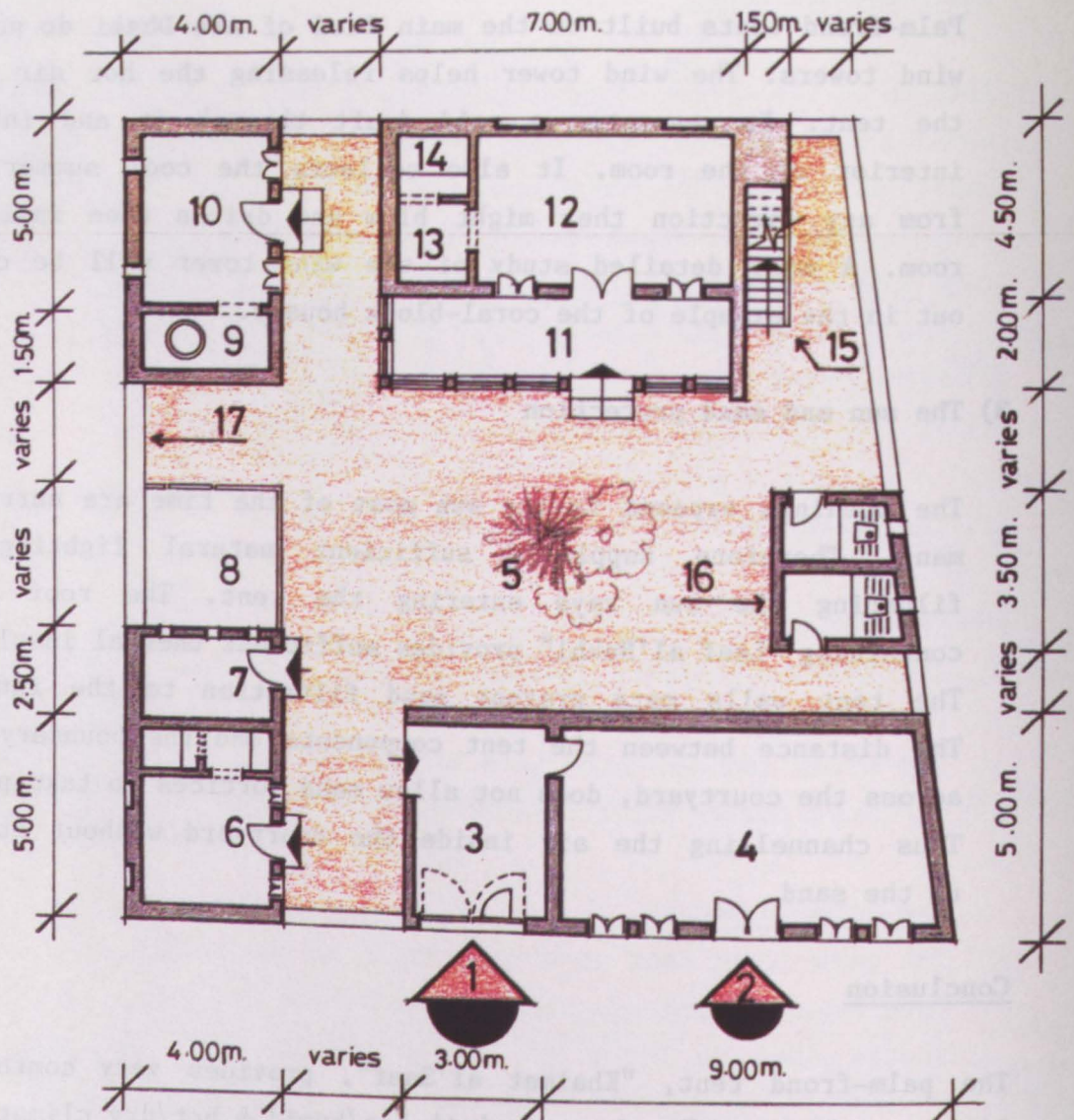

Fig.33 : An example for **baît al'sahel**; the ground floor plan, (B).

Note : This drawing is not to scale; the dimensions shown are approximated.

Key to plan:

- | | | | | | |
|----|--------------|----|---------------------|----|----------------------|
| 1 | al'derwazah. | 2 | al'majlis entrance. | 3 | indirect family ent. |
| 4 | al'majlis. | 5 | al'howey. | 6 | al'khadem. |
| 7 | al'bakhrah | 8 | al'zeribah. | 9 | al'towey. |
| 10 | al'matbakh. | 11 | al'liwan | 12 | al'hograh. |
| 13 | al'zawyah. | 14 | al'qatihah. | 15 | al'daray. |
| 16 | al'hamamt. | 17 | al'hotah. | | |

a'') Bait al'Sahel

Bait al'Sahel is the most elaborate traditional type of house in Abu Dhabi. "Bait al'Sahel" is the local name given for the coral-block house built on the coast of Abu Dhabi.

An example for one of "Biute al'Sahel" is shown in figure 33. "Biute al'Sahel" are generally divided into three main zones (see Fig 34), which are :

- 1) Family/women's zone
- 2) Guests/men's zone
- 3) Services zone

These three zones are built around an open space called "Howey" (see Fig 33). The area of "al'Howey" is confined by the fragmented elements of the house and the boundary walls linking them together. These boundary walls are called "al'Hotah" (see Fig 33). The family entrance to the house, which is called "al'Derwazah", is formed of two large wooden leaves (see Fig 35). The right leaf of the door has an inset openable small shutter called "al'Farkhah" (see Fig 35). It is frequently used for entering the house one person at a time, where "al'Derwazah" is used for entering large items such as furniture. The guests entrance is formed by a double door of smaller size than "al'Derwazah" (see Fig 35).

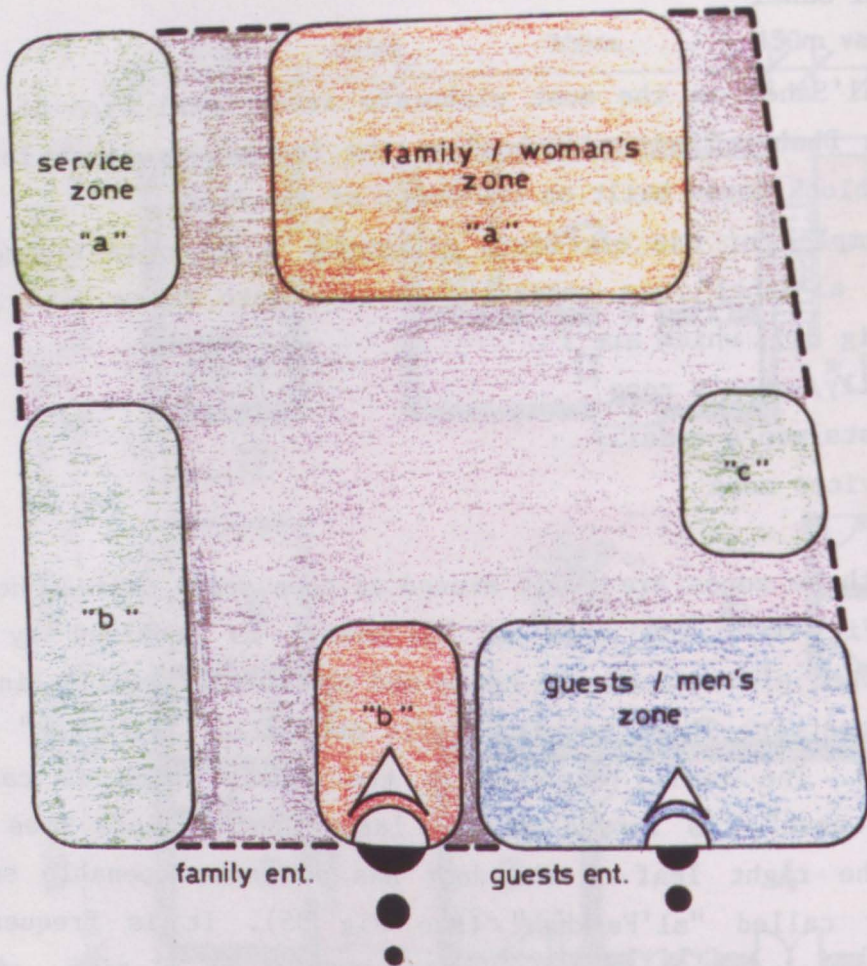

Fig.34 : A diagram showing different zones of bait al'sahel.

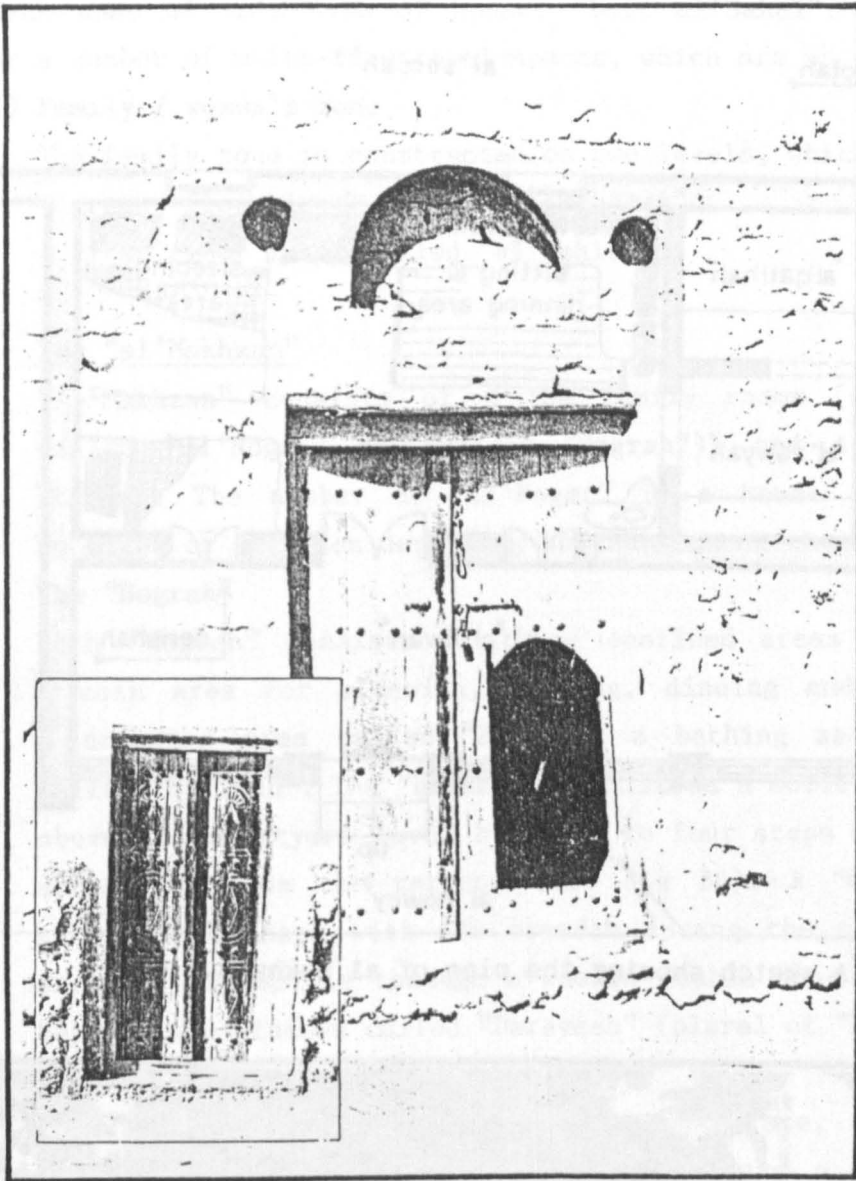

Fig.35 : A photograph that shows the family entrance, and inset is the photograph of the guests entrance, (9).

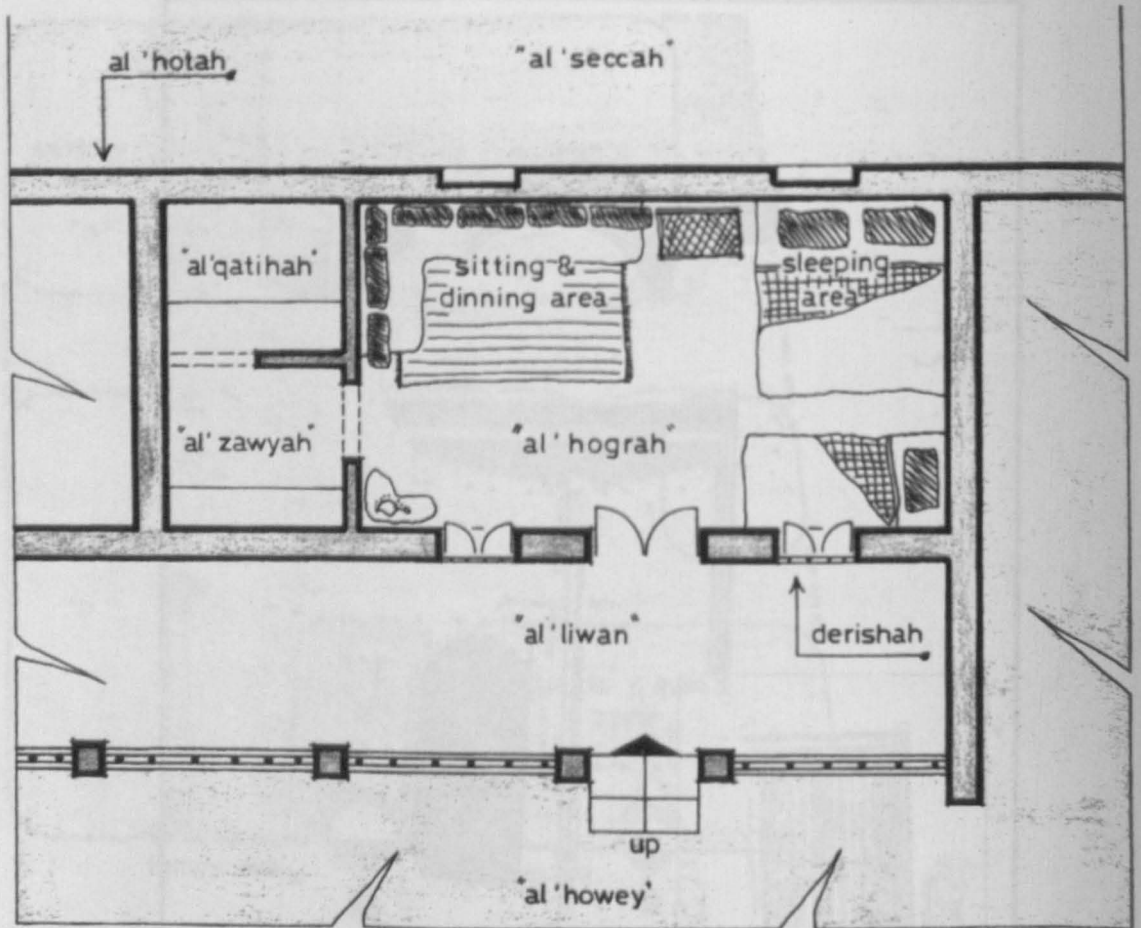

Fig.36 : A sketch showing the plan of al 'makhzan.

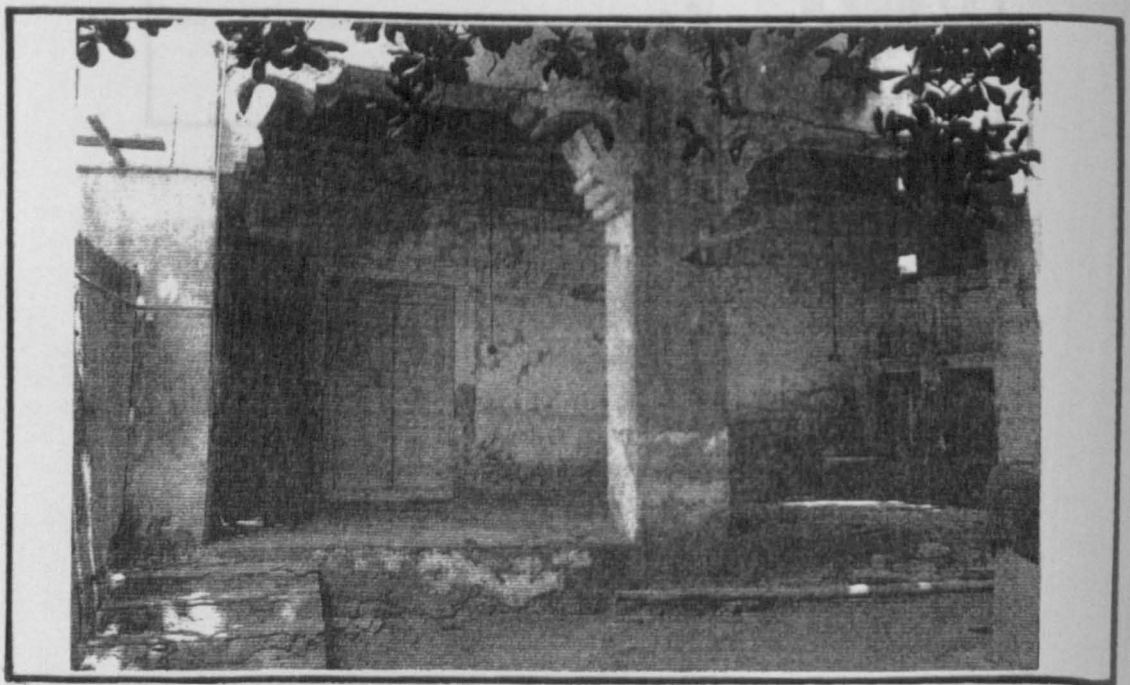

Fig.37 : A photograph of a liwan, (9).

Each zone of this type of house, "Bait al'Sahel", consists of one or a number of multi-functional spaces, which are as follow:

1) **Family / women's zone**

The family zone is constructed on two levels, which are:

- ground floor level called "al'Makhzan"
- first floor level called "al'Dehleez"

The "al'Makhzan"

"Al'Makhzan" consists of : the family rooms (used in winter) called "al'Hogar" (plural of "Hograh"); and a terrace called "Liwan". The number of "al'Hogar" in a house varies from one to eight or even ten depending on the size of the family (9).

The "Hograh"

Each "Hograh" consists of three confined areas (see Fig 36) : a main area for sleeping, sitting, dinning and coffee making; a dressing area called "Zawiah", a bathing and ablution area called "Qatihah". The "Hogar" are built on a solid platform raised above the courtyard level by three to four steps and are directly accessible from the terrace (see Fig 36). A "Hograh" is of a rectangular shape with its breadth facing the courtyard. It is directly accessible through a wooden double door which is placed between two windows called "Darayesh" (plural of "Derishah").

The "Liwan"

The "Liwan", a semi-enclosed outdoor terrace, is on the same level of the family rooms (few houses have a "Liwan" on both ground and first floors). It stretches along the full breadth of the family rooms overlooking the courtyard. It is surrounded by a set of decorated columns supporting the upper floor (see Fig 37). The area of the terrace is confined by gypsum or wooden parapets of decorative patterns constructed between the columns.

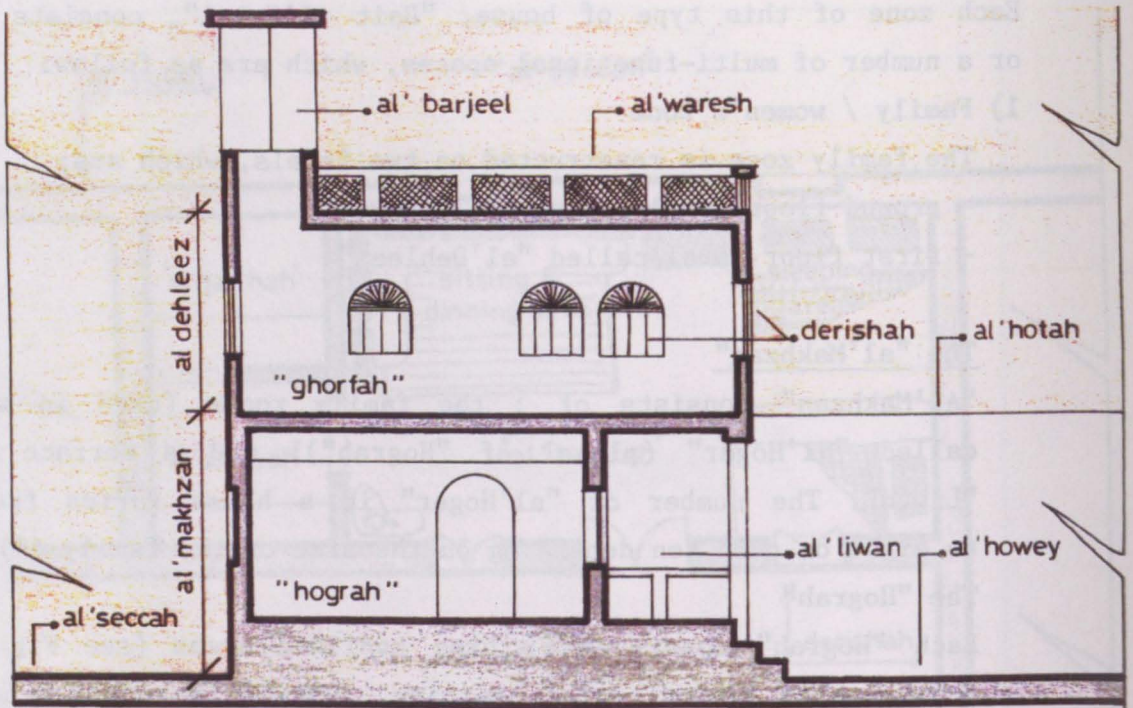

Fig.38 : A sketch showing a section through the family zone.

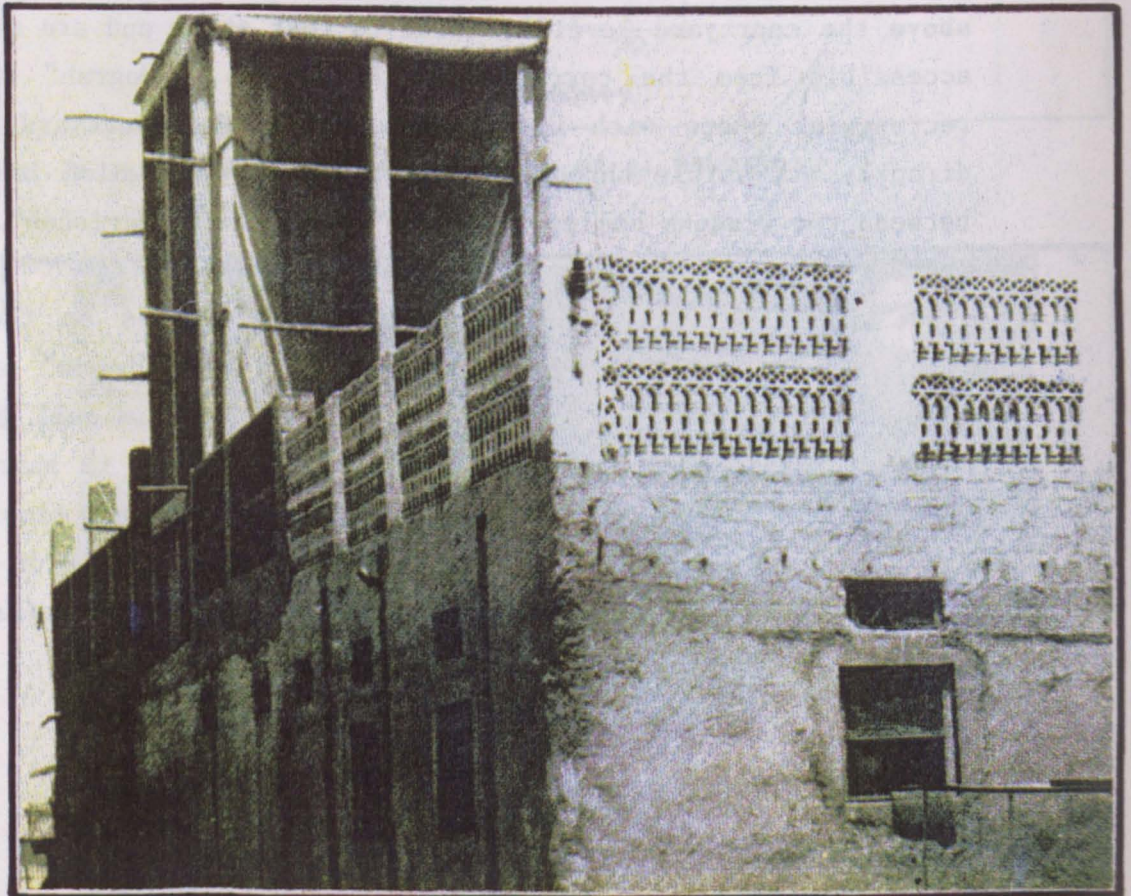

Fig.39 : A photograph showing al'waresh and al'barjeel, (0).

The "al'Dehleez"

The "al'Dehleez" consists of the family rooms (used in summer) called "al'Ghoraf" (plural of "Ghorfah"). They have the same layout of these on the ground floor, but are larger in size (see Fig 38). They are accessible by a staircase called "al'Daray", which is constructed against a solid wall. They also have larger number of windows than their equivalent on the ground floor (see Fig 38). The roof of the "al'Dehleez" is commonly used for sleeping in summer nights when the weather gets too hot to sleep indoor. It is surrounded by a parapet called "al'Waresh" similar to the one on the ground floor. It is made either of gypsum or wooden perforated boards to help circulating the air on top of the roof and prevent visual contact from outside the house (see Fig 39). A wind tower, called "al'Barjeel", is constructed on one of the roof corners (see Fig 39). It collects the cool summer wind from every direction and channels it into the "al'Dehleez".

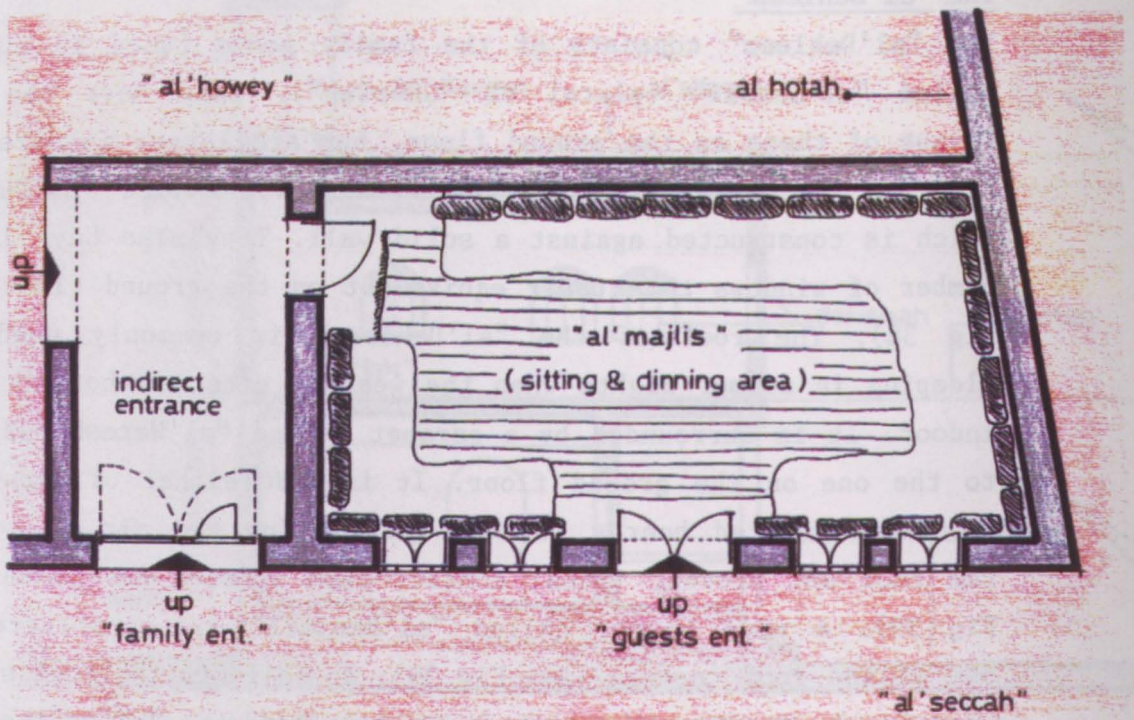

Fig. 40 : A sketch showing the plan of al' majlis.

2) Guests / men's zone

The guests / men's zone is constructed on the ground floor level. It consists of one main confined room called "al'Majlis" which is, commonly, of rectangular shape. It is used as a sitting and dining room for male guests. It is built on a solid platform raised above the street level by one or two steps. The "Majlis" has two entrances (see Fig 40) : a main double door located between two or four windows allowing guests to have direct access from the street; another single door forming an access from the indirect family entrance and thus allowing male members of the family to have direct access from inside the house. Another wind tower "Barjeel" is constructed in one of the corners of "al'Majlis" roof to provide it with cool air in the summer season.

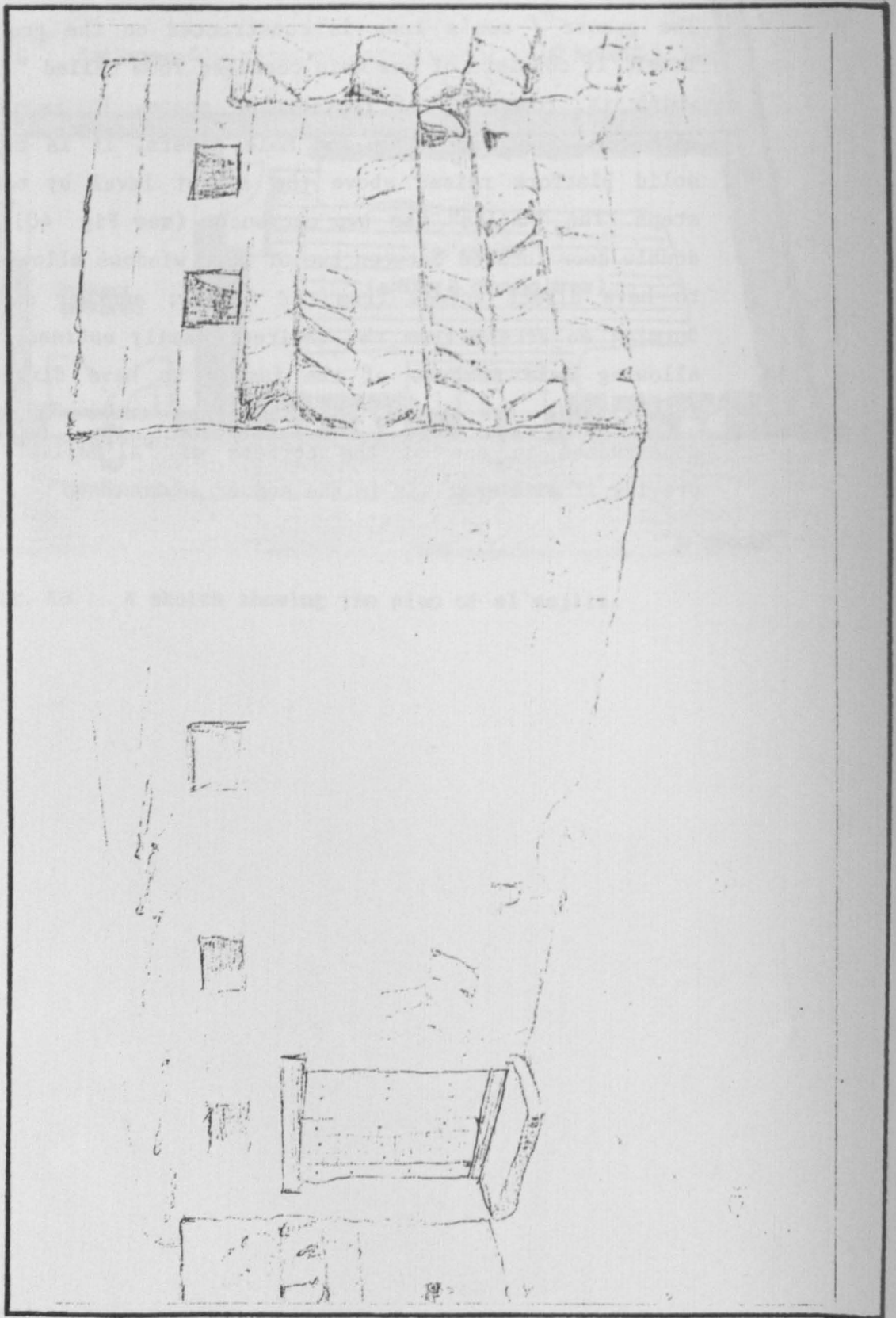

Fig. 41 : A sketch showing al'bakhar.

3) Services zone

The services zone is located on the ground floor level. It consists of six confined spaces (see Fig 33), which are :

- a kitchen called "al'Matbakh"
- a water well called "al'Towey"
- a ranch called "al'Zeribah"
- a store called "al'Bakhar"
- a servant room (if there is any) called "al'Khadem"
- water closets called "al'Hammamat"

The "al'Matbakh"

The "al'Matbakh" has a rectangular shape and is raised above the courtyard level by a step or two. It consists of a large area for preparing and cooking the food. It has one door located between two windows, and several high levelled narrow openings each called "Qemry". These openings provide the kitchen with natural ventilation.

The "al'Towey"

The "al'Towey" is a brackish water well. It is dug in a confined space within the kitchen area to provide water for cleaning, washing and bathing.

The "al'Zeribah"

The "al'Zeribah" is a fenced area for poultry, and domestic animals such as sheep. It has in one of its corners a small fodder store.

The "al'Bakhar"

The "al'Bakhar", singular of "Bakhakheer", is raised above the courtyard level by one step or two. It is used for storing rice, flour and dates (see Fig 41).

The "al'Khadem"

The layout of "al'Khadem" room is similar to that of a "hograh" but without a "liwan" (see Family / women's zone). It is raised

above the courtyard level by one step or two.

The "al'Hamamat

The term "Hamamat" is the plural of "Hamman". A "Hamman" consists of an asian type w.c. Each "Hamman" has one door connecting it with the courtyard and one "Qemry" on its exterior wall located above the w.c. The "al'Hamman" has two floor traps one is located underneath the w.c. and the other is located outside the house.

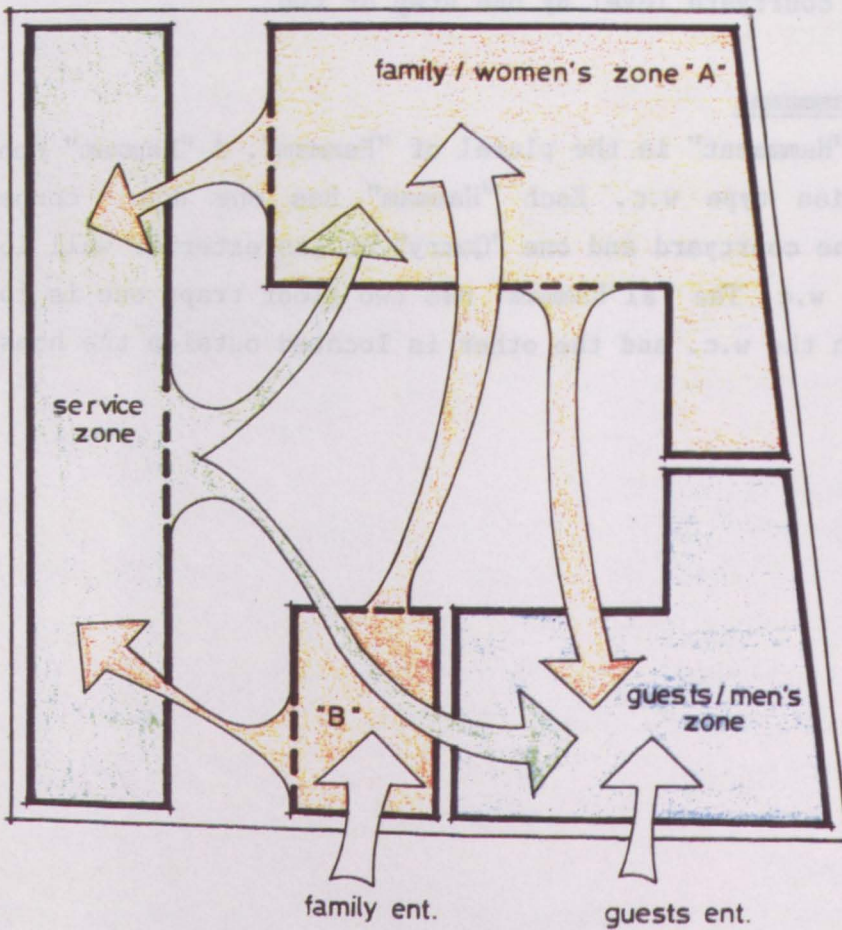
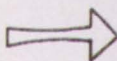

Fig. 42 : A diagram showing the flow of circulation between different zones of the house.

Key:

 this arrow shows the direction of the main flow of circulation between different zones of the house.

Functional Aspect

The house of "Bait al'Sahel" is divided into three main zones (see Fig 34). Each one of these zones has a certain function. They are as follow :

1) Family / women's zone

It contains the family rooms where each member of the family has, most of the time, his/her own self contained room.

2) Guests / men's zone

It contains the male guests reception "al'Majlis", where male members of the family receive their male guests.

3) Services zone

It contains all the services that are required to assist life in the house, such as : a kitchen, a small ranch, a store.

These three zones are laid out together in order to maintain the required functional performance of each one. Laid out around a courtyard an uninterrupted flow of circulation between the three zones of the house is garenteed (see Fig 42). The layout of the zones of "Bait al'Sahel" allows the family members (males and females) to have direct access, from outside the house "al'Seccah", to either the family / women's zone or to the services zone passing through the courtyard. Accessibility between the family / women's zone and the services zone is also maintaind by passing through the courtyard. Guests have a direct access, from outside the house "al'Seccah", to the guests / men's zone without passing neither through the family / women's zone nor the services zone. Male members of the family and family servants have an indirect access, from inside the house, to the guests / men's zone passing through the indirect family entrance. Therefore allowing the family male members to hoste their guests without interrupting their everyday family life inside the house.

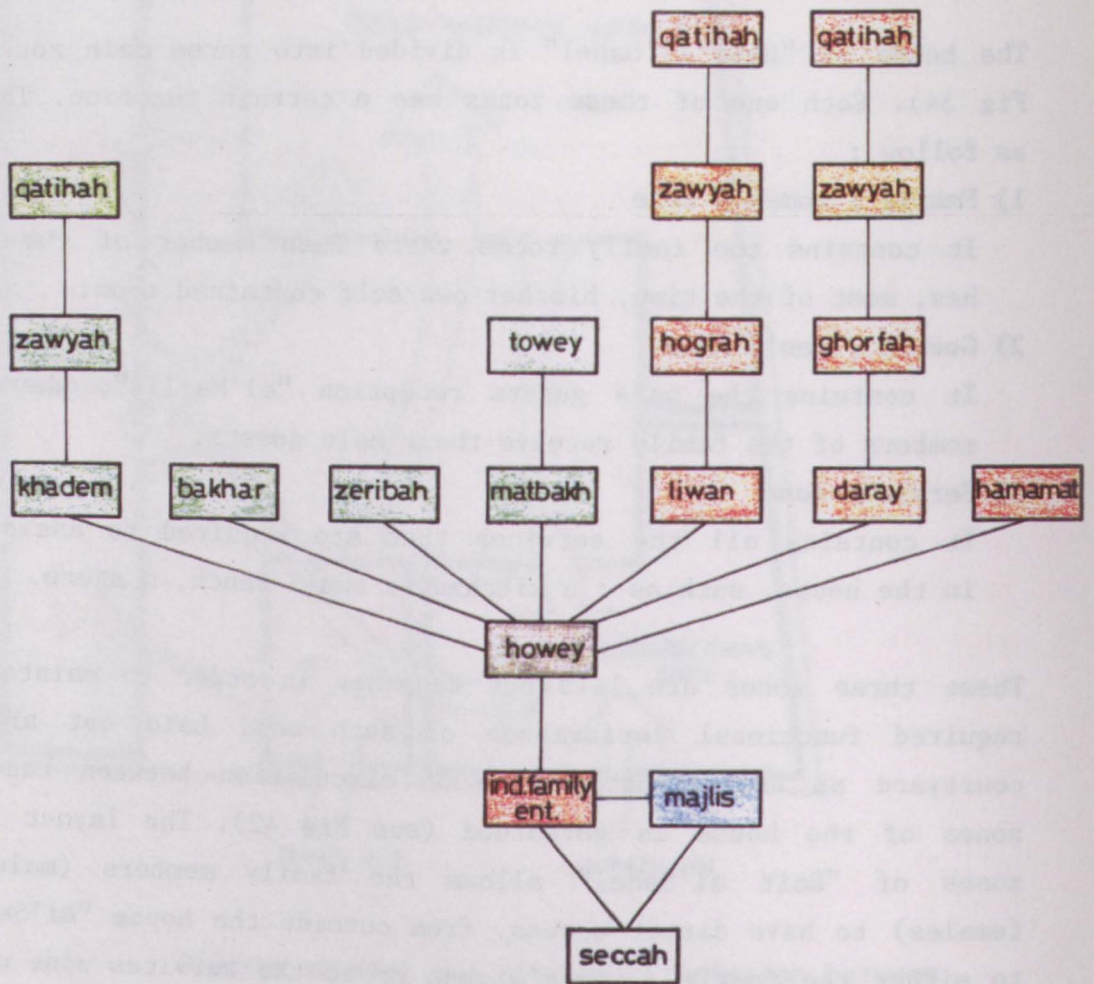
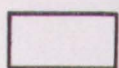

Fig. 43 : A map showing the hierarchical spatial organisation of "bait al sahel"

Note : This map is based on the direct accessibility from one space to the other.(4)

Key:



a space in the house



one step = a movement from one space to another

In figure 43, the house is divided into a number of layers based on the equal number of movements leading to different spaces among it. This number of movements is in relation with the public space "al'Seccah". The more number of movements needed to reach a certain space inside the house, the deeper this space is. Spaces having a certain depth, therefore lying in the same layer, possess a certain degree of permeability. The presentation and analysis of the house of "Bait al'Sahel" leads to the fact that : The increasing depth of the house different layers results in a highly impermeable (to strangers) layout.

Beginning from the public area of approach to the house "al'Seccah", the penetration of the house spatial pattern is controlled. That is by providing the house by two functional links with the public space. The first link is the guests entrance. It allows guests and visitors to have a direct contact with a very shallow space of the house "al'Majlis", which is especially reserved for receiving guests (see Fig 43). The second link is the family entrance "al'Derwazah". It allows a direct contact between a very shallow space of the house "the indirect family entrance" and the public space. Both "al'Majlis" and the "indirect family entrance" have the same depth, therefore lying in the same layer (see Fig 43). The indirect family entrance having the same depth and degree of permeability as those for "al'Majlis", leads to number of family / women's and services spaces. The spaces have an increasing depth equivalent to the function of each one of them. Various depths are related to the activities carried out in them. The increase in depth of each space is governed by the degree of privacy it requires. The increasing depth of different spaces of the house performing different functions, resulted in its sequential spatial organisation.

Figure 44 (a,b,c) shows the main spaces of "bait al'sahel". A graphic interpretation of the division of spaces in accordance with the different activities carried out in them is also shown. The actual areas of spaces are neglected. The various spaces forming the three zones of "bait al'sahel" are characterised by being multi-functional spaces. Most of the spaces, if not all, perform a number of functions at different times of the day. For example : the family rooms "al'hogar" / "al'ghoraf" are functionally divided into two main areas, an area which is used for sleeping at night or in the afternoon, and a day use area for sitting and dining (see Fig 36). Another example is "al'majlis" (see Fig 40), where the space is used for both sitting and dining.

FIG. 44(a) : A table showing the different activities carried out in different spaces of "bait al sahel", and their graphic interpretation.

SPACE TITLE	ACTIVITIES CARRIED OUT IN THE SPACE	GRAPHIC INTERPRETATION
Al'Makhzan	<p>= HOGRAH + ZAWYAH + QATIAH</p> <p>(living / bedroom) (dressing room) (bathroom)</p> <p>= [sleeping, sitting & dinning] + [changing room, clothes store] + [bathing & ablution]</p>	
Al'Dehleez	<p>= GHORFAH + ZAWYAH + QATIAH</p> <p>(living / bedroom) (dressing room) (bathroom)</p> <p>= [sleeping, sitting & dinning] + [changing room, clothes store] + [bathing & ablution]</p>	
Al'Majlis	<p>= GUEST RECEPTION</p> <p>= [sitting & dinning]</p>	
Al'Khadem	<p>= HOGRAH + ZAWYAH + QATIAH</p> <p>(living / bedroom) (dressing room) (bathroom)</p> <p>= [sleeping, sitting & dinning] + [changing room, clothes store] + [bathing & ablution]</p>	

Fig. 44(b)





SPACE TITLE	ACTIVITIES CARRIED OUT IN THE SPACE	GRAPHIC INTERPRETATION
Al'Matbakh	= MATBAKH + TOWEY (kitchen) (water supply) = [food preparation & cooking] + [dish washing, clothes washing]	
Al'Liwan	= TERRACE + CIRCULATION (outdoor sheltered sitting space) (the link between the courtyard and al'hogar.)	
Al'Bakhar	= STORE + HONEY MAKING (food storage) (honey making from dates)	
Al'Zeribah	= FODDER + ANIMALS SHELTER	

Fig. 44(c)

SPACE TITLE	ACTIVITIES CARRIED OUT IN THE SPACE	GRAPHIC INTERPRETATION
Al'Howey	<p>= COURT YARD</p> <p>(protected open area for family gathering and celebrations, circulation, children playground & gardening.)</p>	
Al'Hamm - amat	<p>= WATER CLOSETS</p> <p>(W. Cs. only)</p>	

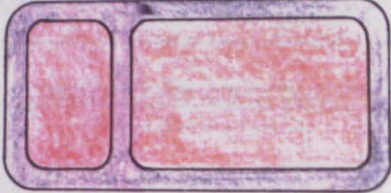
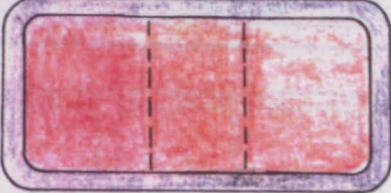
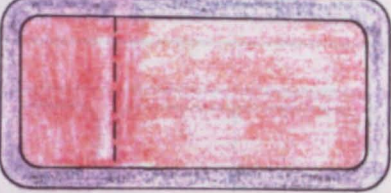
Conclusion

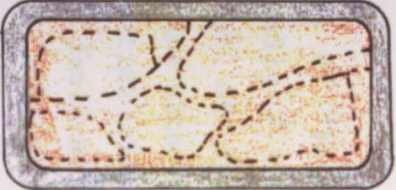
The house of "bait al'sahel" consists of three main zones which are : family / women's zone, guests / men's zone, services zone. The layout of these zones maintains the required accessibility between them without obstructing one circulation flow from the other. Representation and analysis of the structure permeability of "bait al'sahel" feature its main characteristic, which is the sequential layout of spaces highly impermeable to strangers. Therefore, the syntactic theme of "bait al'sahel" is that it has a hierarchical spatial organisation. Another main characteristic is that each space in the house performs more than one function except the w.c.

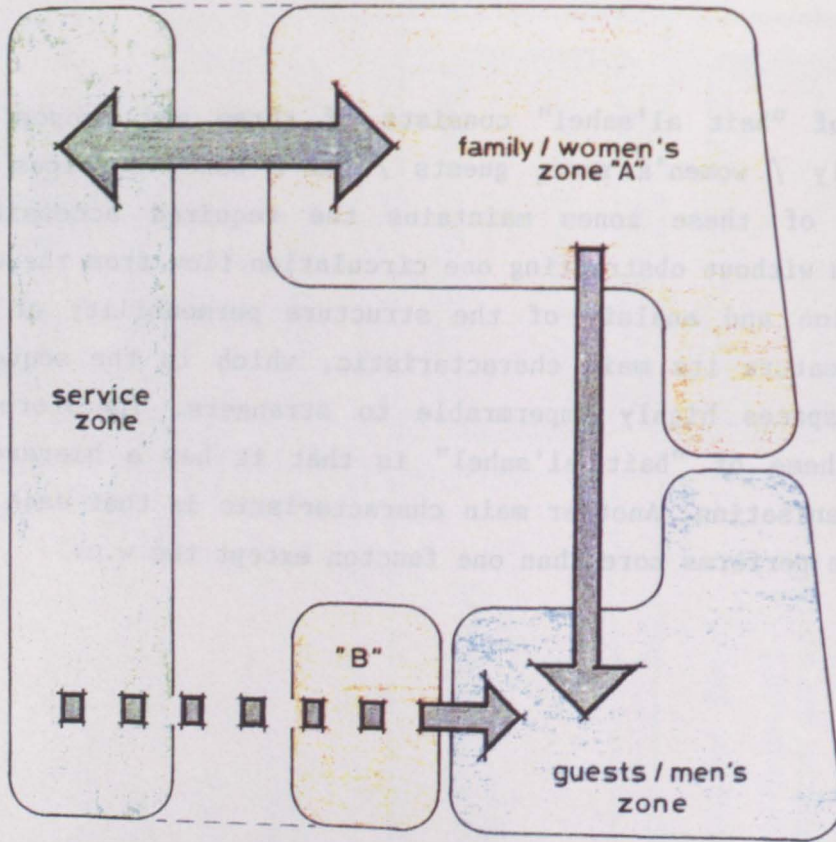
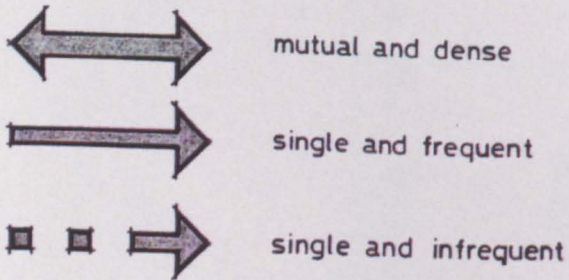

Fig. 45 : A diagram showing communication degrees between the house zones.

Key :



Socio-cultural aspect

The design of "bait al'sahel" is the direct interpretation of the social behaviour patterns of its households. The socio-cultural background of the local people induced a very important social value; Privacy. Communication between different zones in the house is governed by the degree of privacy each zone requires (see Fig 45). Communication between spaces in each zone is also governed by the degree of privacy that each space requires. Supplying the required protection for each space, thus for each zone, from immediate visual and aural inspection, resulted in hierarchical spatial organisation of multi-functional spaces (see Fig 46). These spaces are confined within the family, guests, and services zones.

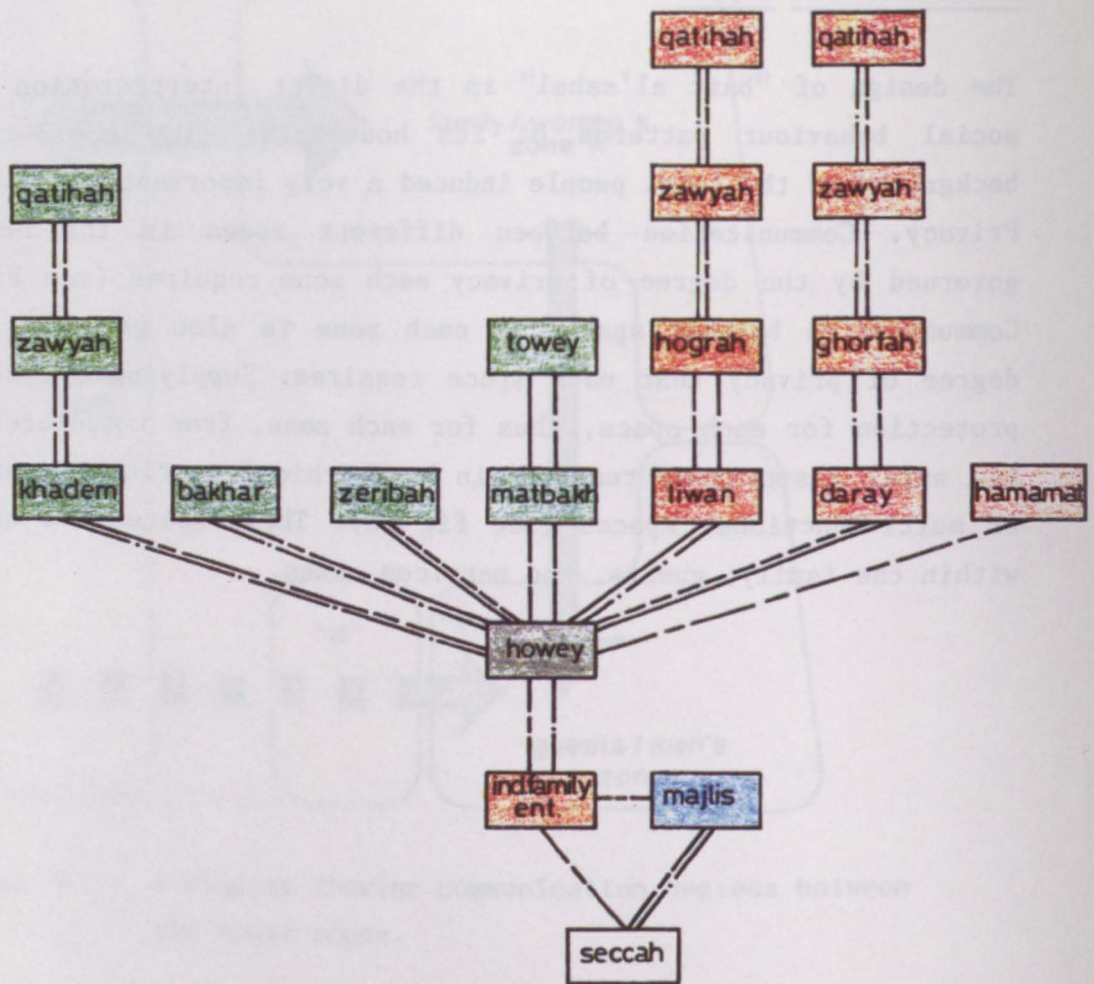

Fig. 46 : A map showing the types of communication between different spaces of the house of "bait al'sahel".

Note : This map is based on the immediate audio / visual inspection from any space on the next permeable space (5)

Key :

- a space in the house
- direct oral
- indirect oral
- direct visual
- indirect visual

Separation of zones

In fulfilment of the value of privacy even inside the house, separation of the house into three zones was required. This was achieved by building them around a courtyard. Thus, to move from one zone to the other, one has to pass through the family protected outdoor area "al'hoaway". The location of each zone within the house was chosen carefully to maintain high functional performance without interrupting each other's privacies. The guests / men's zone is directly accessible from the outside of the house. It has outdoor overlooking windows only, and its common wall with the house courtyard is absolutely solid (see Fig 33). The family / women's zone is located deep inside the house. It is indirectly accessible from outside the house through an indirect family entrance. On the contrary to the guests / men's zone it has its windows overlooking the courtyard, while having solid exterior walls (see Fig 33). Services zone is located in order to allow easy access to the family members to support their every day life. It allows also controlled contact with guests / men's zone through the servant being located next to it (see Fig 33). In the case of having no servants, then contact between both zones is carried out by junior male family members to serve male guests and offer them arabic coffee for example.

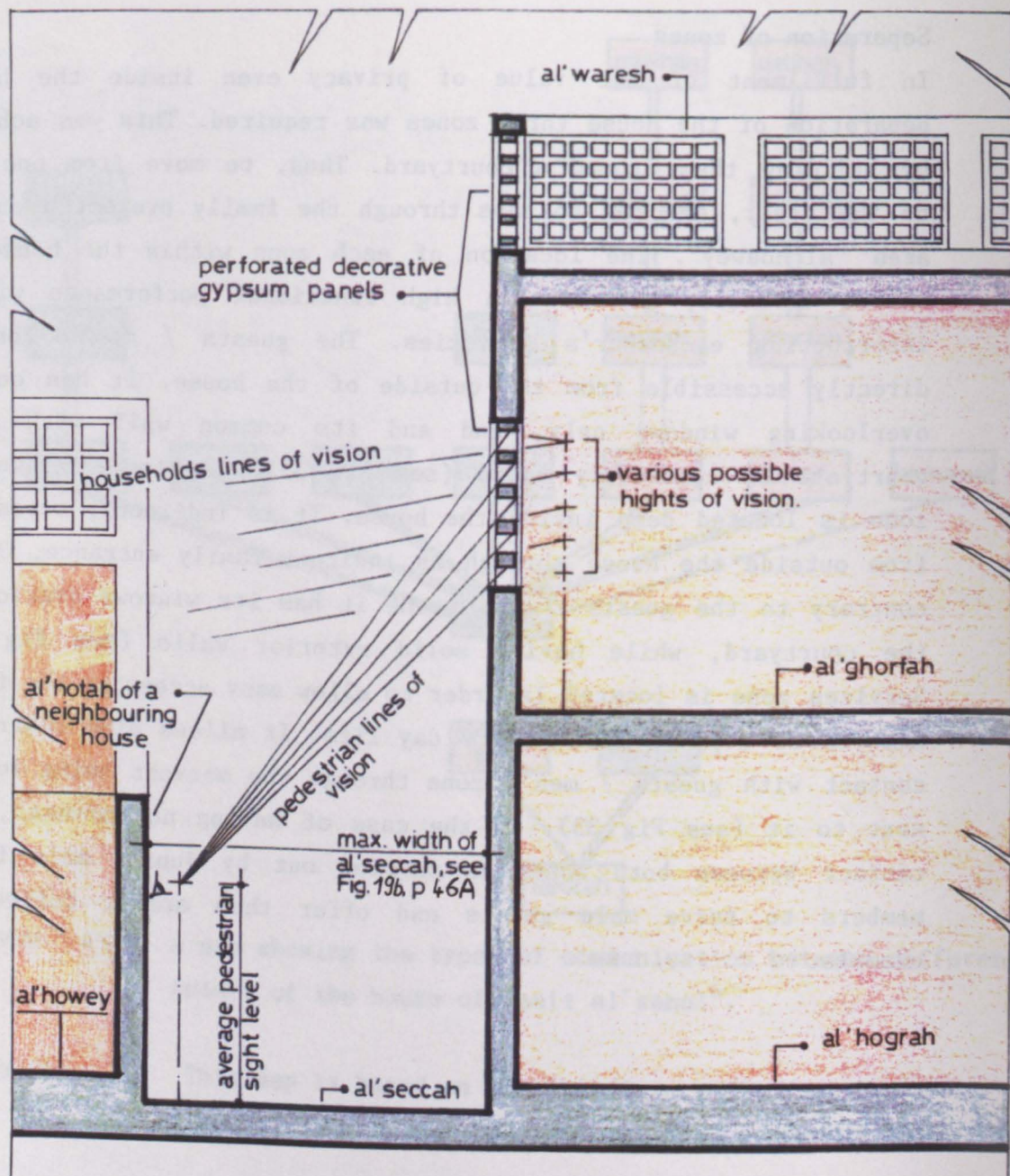

Fig. 47 : A sketch that shows how immediate visual inspection was controlled, both from outside and inside .

A courtyard house

"Bait al'Sahel" was designed and built overlooking a family common space, a courtyard "al'howey". This type of house allowed the family to have a private and protected outdoor space within the house area (see Fig 33). The ground floor components of the house are overlooking the courtyard, while having solid exterior walls. This helps preventing audio/visual intrusion from outside the house. The first floor components are overlooking both inside and outside the house. Openings in their exterior walls "al'darayesh" are higher than the average pedestrian eye sight level. Nevertheless, they are protected by perforated gypsum panels of decorative patterns. These gypsum panels do not allow visual inspection from the level of "al'seccah" to the inside of the house. They allow visibility from inside the house towards the horizon, therefore protecting the privacy of the courtyards of the neighbouring houses (see Fig 47).

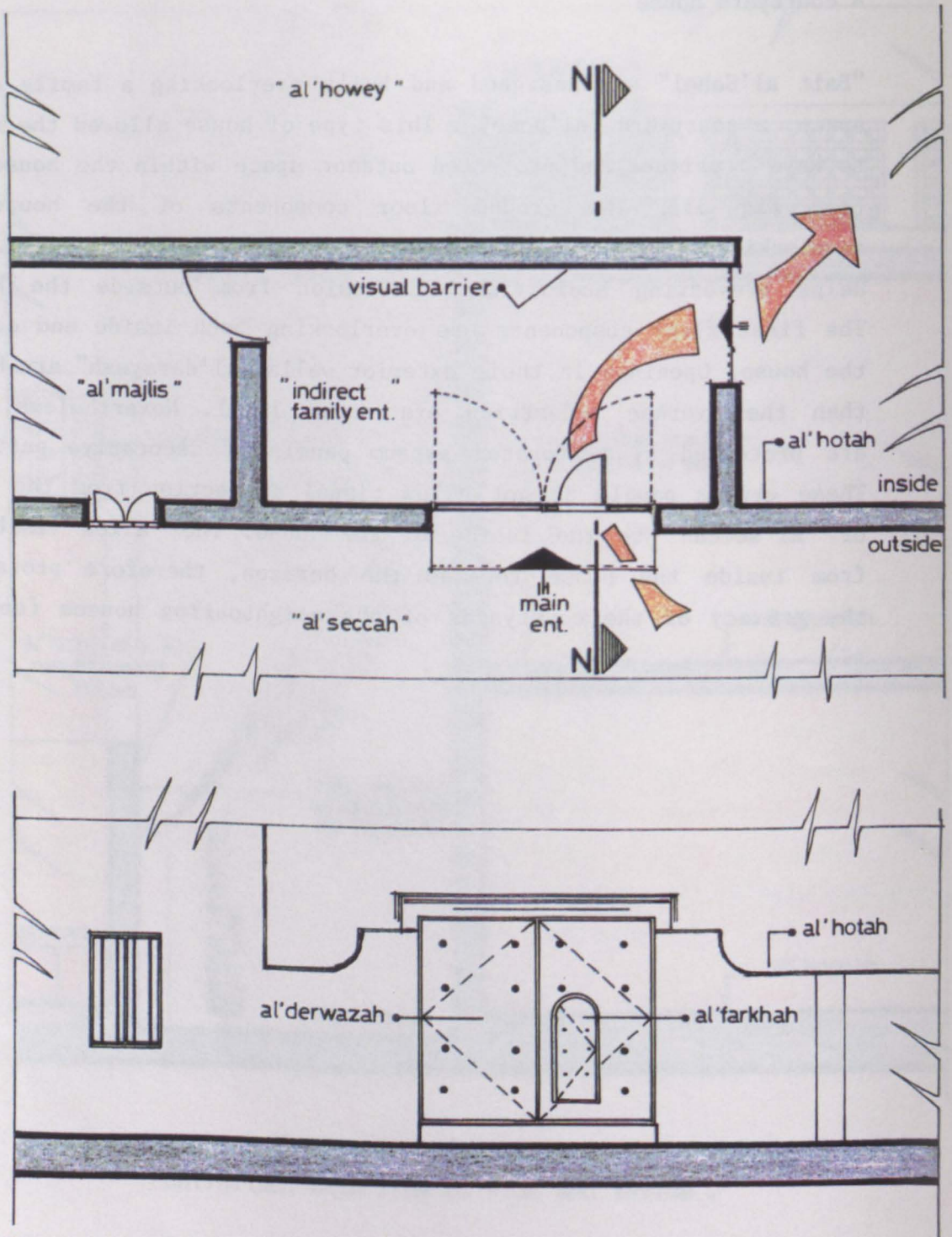

Fig. 48 : A sketch that shows the indirect family entrance in plan and in elevation .

Separate entrances

Seeking absolute privacy, separation between family / women's zone and guests / men's zone was accompanied by separation of entrances to both zones. This resulted in having "al'majlis" entrance which leads directly to the guests / men's zone, and having "al'farkhah" which leads to the indirect family entrance. Then to the family / women's zone (see Fig 33).

Indirect family entrance

Another interpretation of privacy measurements appears in the design of the family entrance. Its main characteristic is being indirect (see Fig 48). It prevents direct visual inspection on the family common space "al'hoaway". In addition to this, "al'derwazah" having a small single door "al'farkhah" for entering the house, permitted a certain behaviour and restricted field of vision to the person entering the house. "Al'Farkhah" being narrow and low allows only one person to enter at a time.

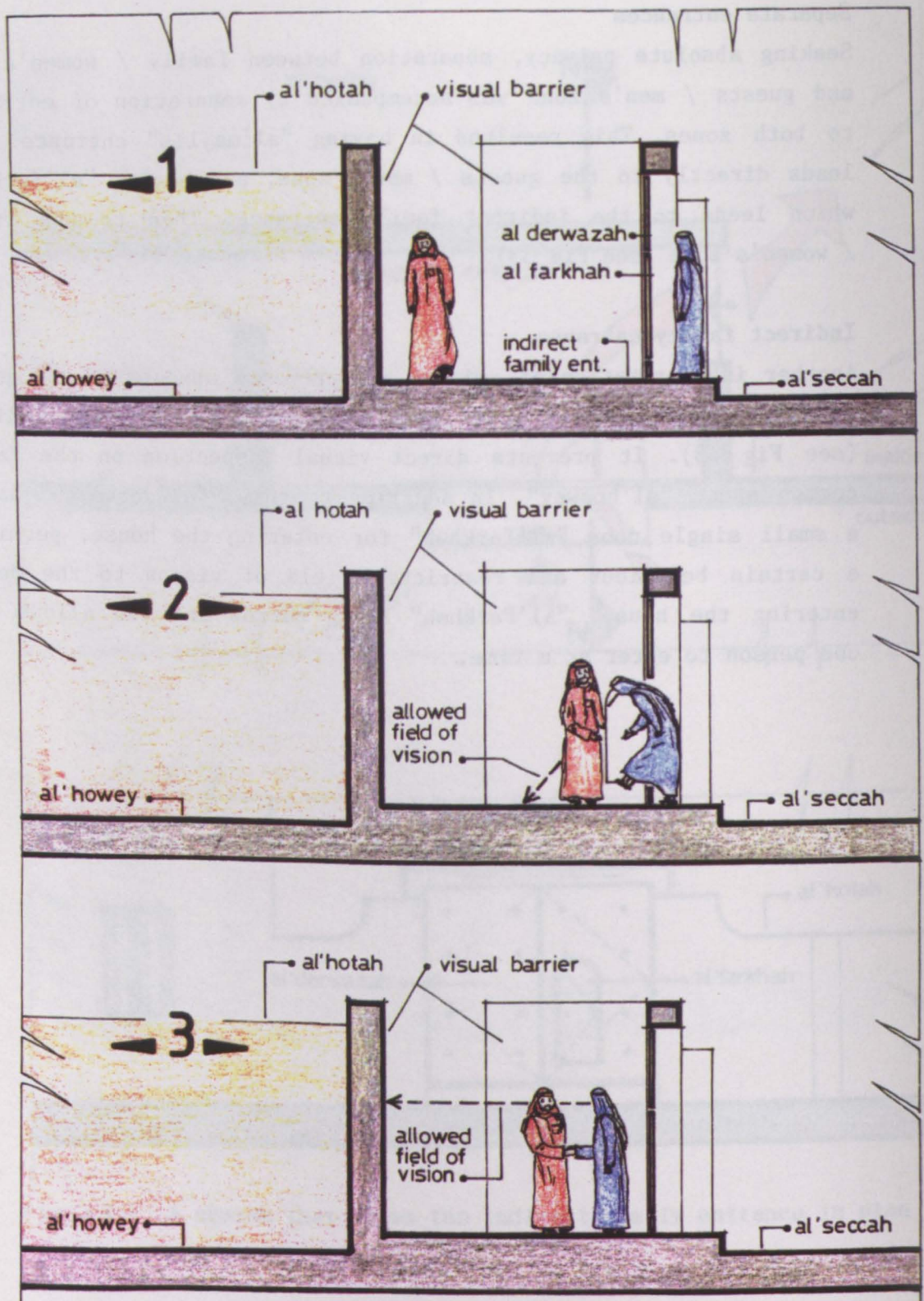

Fig. 49 : A sketch that shows the three stages of entering to the indirect family entrance .

Figure 49 consists of three sketches showing the three stages of entering through the indirect family entrance, which are :

- 1) The visitor standing outside the house and in front of the "al'farkhah". This sketch shows that the top of "al'farkhah" is lower than the eye sight level of the visitor. Thus preventing the visitor from having direct and straight visual inspection on the inside while the "al'farkhah" is being opened by one of the family members.
- 2) The visitor has to bow in order to pass through "al'farkhah". Thus, having a very restricted field of vision, which enables the visitor only of stepping inside the indirect family entrance.
- 3) When the visitor is standing upright being received by the family member, his / her field of vision is restricted by a visual barrier. This visual barrier prevents the visitor from having immediate visual inspection on the rest of the house.

Boundary wall

The boundary wall "al'hotah" links the exterior solid walls of the house components. It completes the privacy of the courtyard of the house. Having sufficient height, it prevents direct visual inspection from outside (see Fig 47).

Conclusion

The separation of the house zones in the house of "bait al'sahel" maintains the required privacy for each zone. Different spaces in the house of "bait al'sahel" requires different degrees of privacy. Representation and analysis of the social structure of "bait al'sahel", in accordance with its permeability structure (see Functional aspect) leads to the fact that : The depth of any space in the house of "bait al'sahel" is governed by the degree of privacy it requires. Therefore, the higher the degree of privacy the deeper the space becomes.

The design of "bait al'sahel" protects the privacy of the households from being affected by strangers. It does not only prevent immediate audio/visual inspection of pedestrians on the house, but also households on neighbouring houses.

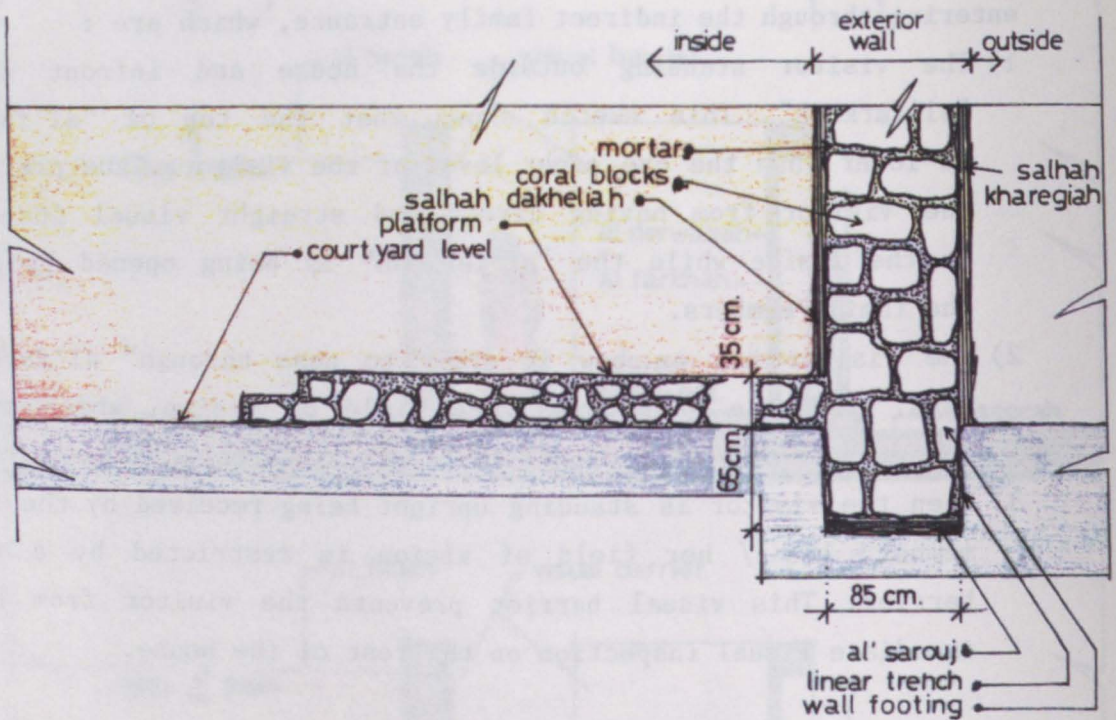

Fig. 50 : A sketch showing a section passing through an exterior wall, the platform and the wall footings.

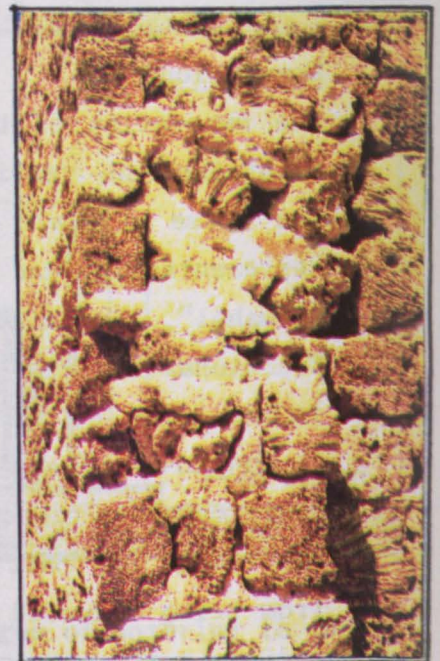

Fig. 51 : A photograph showing the coral blocks in a wall section (14).

Technical Aspect

The process of building "bait al'sahel" was carried out utilising natural building materials. These building materials were either extracted from the natural sources of the local environment, or imported from neighbouring and remote similar environments. The local builders applied a traditional method of construction in building "bait al'sahel". A detailed analysis of the utilised building materials and the applied method of construction will be carried out.

Building materials

The main building materials utilised in the construction of "bait al'sahel" are :

1. Al'Hassa
2. Al'Yass
3. Al'Salby
4. Al'Chandel wood
5. Al'Sherback
6. Leaf al'nakhl
7. AL'Salhah
8. Al'Sarouj

1. Al'Hassa

The coral is locally known as "al'hassa" (see Figs 50, 51). It is extracted from the local waters of the emirate of Abu Dhabi. The coral reef which stretches along the western coast of the emirate forms the natural source of "al'hassa". It was a very well known area to the local divers. The coral was extracted only in summer, when it could be left out in the sun to dry up. Then it was cut into blocks where it was used in constructing the walls, and the boundary walls of "bait al'sahel". The coral or "al'hassa" forms the main solid building material for the following reasons:

* the lack of alternative solid building materials such as stones

Fig. 52 : A photograph showing the house walls in section, and the plaster applied on the interior walls (14).

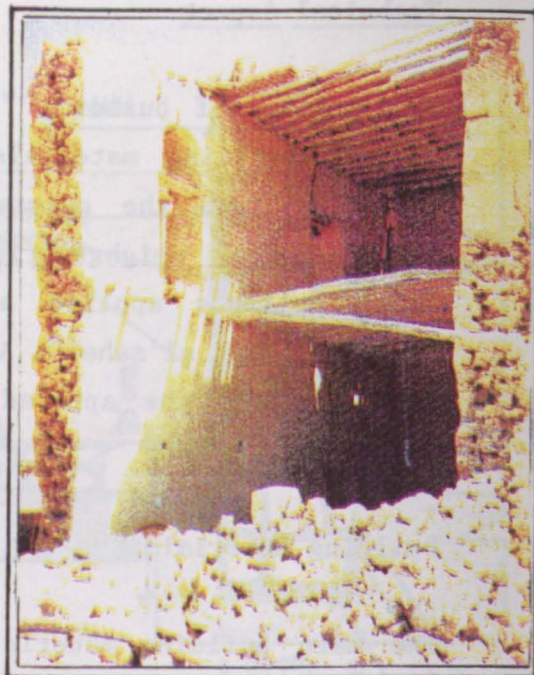
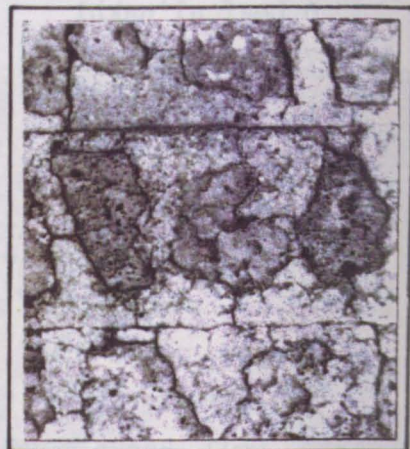

Fig. 53 : A photograph showing the horizontal layers of the coral blocks and the horizontal & vertical binding mortar (15).



or rocks.

* the coral becomes very light in weight after it dries up in the sun.

* the coral is highly porous, thus having very low density which are the characteristics that qualify the coral to be highly recommended thermal insulator.

2. AL'Yass

The calcium stones were used in making the binding mortar. This mortar is known locally as "al'Yass". The calcium stones are imported from Persia. These stones were cut into small pieces then crushed and ground into powder. This powder is then mixed with water to form the mortar that binds the coral blocks together (see Fig 53).

3. Al'Salby

Al'Salby is a mix of a reddish brown clay, imported from Persia, and straw. It was used as a finishing layer of the roof of "bait al'sahel" (see Fig 58), and as the exterior plaster for the house walls and the boundary walls.

4. Al'Chandel wood

Al'Chandel wood is the local name given to a certain species of wood that was imported either from Malabar - India, or east of Africa (11). It was mainly used as beams in the construction of "bait al'sahel" (see Figs 56, 61).

5. Al'Sherback

Al'Sherback is the local name given to the palm tree branches. The branches, stripped of their leaves and spikes, were bound together into mats forming one of the roof layers of "bait al'sahel" (see Fig 56).

6. Leaf al'Nakhl

Leaf al'Nakhl is the local name given to the fibrous bark that grows at the bottom of the palm trees. It forms one of the layers

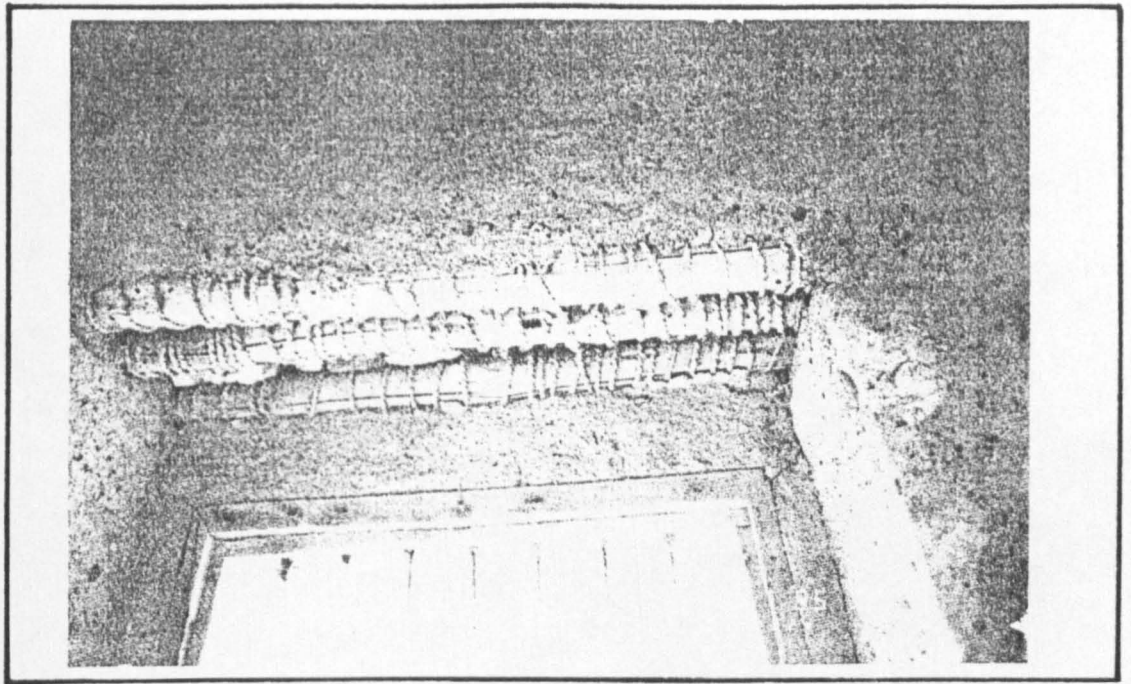

Fig. 54 : A photograph showing "al'chandel wood" of a window lintel, (15).

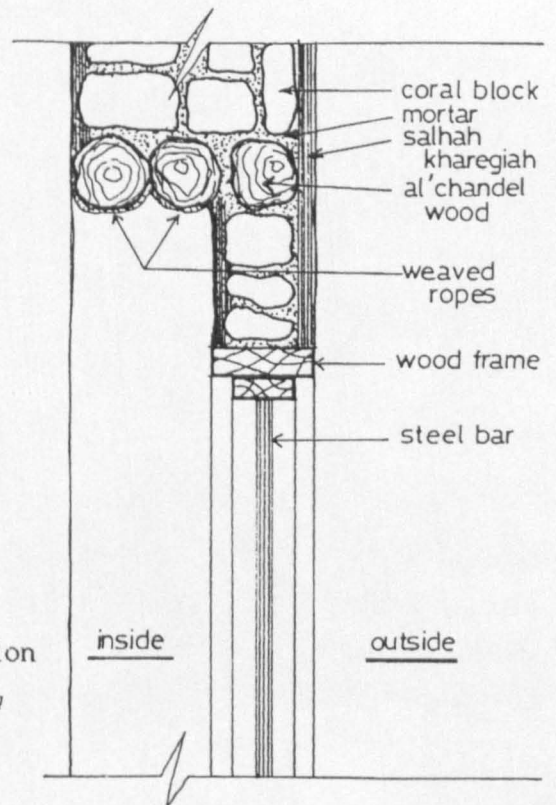

Fig. 55 : A sketch showing a section passing through a window opening .

of the roof of "bait al'sahel" (see Fig 58). It was used as well in weaving ropes which was used in tying "al'chandel" wood trunks together in the windows and doors lintels (see Fig 54).

7. Al'Salhah

Al'Salhah is the local name of the walls plaster. There are two different kinds of plaster applied in the house of "bait al'sahel", which are :

a) Salhah dakheliah

Salhah dakheliah is the local name of the plaster applied on the interior walls of the house (see Figs 52, 59). The term "dakheliah" means interior. The plaster consists of the same materials as those of "al'yass".

b) Salhah kharegiah

Salhah kharegiah is the local name of the plaster applied on the exterior walls of the house, columns and boundary walls (see Fig 61). The term "kharegiah" means exterior. The plaster consists of the same materials as those of "al'Salby".

8. Al'Sarouj

Al'Sarouj is the local name of the mixture consisting of a reddish brown kind of clay imported from Persia, mixed with manure. This mixture is dried up and baked in kilns before usage. It was used as a lining material to the footings of the house walls (see Fig 50).

Method of construction

The house of "bait al'sahel" was constructed by builders, who stood in a line of sons who had learnt from their fathers how to design and construct houses in order to minimise the discomfort of heat and humidity (12). A description of the method of construction applied by the local builders will be briefed in the following steps (13), which are :



Fig. 56 : A photograph showing "al'chandel wood" trunks and "al'shererback" in a roof of a ground floor room (10).

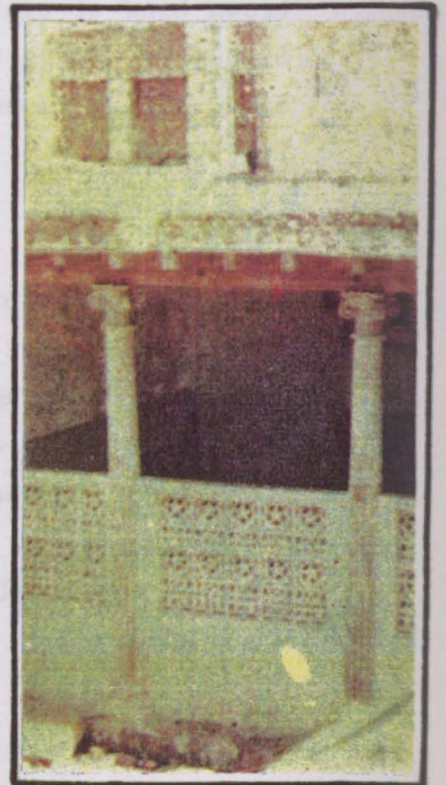

Fig. 57 : A photograph showing a section in a first floor slab (16).

1. The walls footings

The walls footings were constructed by digging linear trenches of 2 - 2.5 ft. in depth (see Fig 50) in the ground, and of 2.5 - 3 ft. in width determining the walls location. Thus determining the shape of the house rooms which were often of a rectangular or trapezoidal geometric shapes. These trenches were lined by "al'sarouj". Then the footings were constructed by laying big coral blocks on top of "al'sarouj" in horizontal layers bound with "al'yass", until the construction reaches the height of 1 - 1.5 ft. above the ground level. That is the equivalent rise of two or three steps above ground level.

2. The platform

The spaces defined by the projecting tops of the walls footings above the ground level were then filled up with lumps of coral (see Fig 50). Then "al'yass" was poured on top of the coral lumps to give a levelled, smooth texture for the platform. The platform thickness is about one foot.

3. The walls

Walls were then constructed on top of the projecting edges of the footings. This process was carried out by laying shaped coral blocks in horizontal layers and binding them with "al'yass" (see Figs 51, 53). The walls range in thickness from 1.5 to 2 feet (see Fig 50). Taking into consideration the location of the doors and windows, the house openings were of the same thickness of the walls (see Fig 52).

4. Lintels

Lintels formed by binding chandel wood trunks together with weaved ropes with of adequate size to the wall openings (see Fig 54). Lintels were laid on top of the wall openings with suitable overlapping on both sides. The wall construction continues then until it reaches the desired height of the ground floor (see Fig 55).

5. The first floor

The first floor was constructed by laying "al'chandel" wood trunks in the perpendicular direction of the room longer span and resting on the top edges of the walls, with 1 - 1.5 ft in between each other. These trunks formed the roof beams (see Fig 56). Then "al'sherback" mats were laid on top of the trunks in a direction parallel to that of the room span with suitable overlapping between each two following mats. The construction of the first floor walls then continues until it reaches the desired height of the final roof. Small lumps of coral were then laid on top of "al'sherbak" and covered with mortar "al'yass" to give a solid and finished floor level (see Fig 57). Window and door lintels were then constructed in the same way as those of the ground floor.

6. The roof

The construction of the roof was the same as that of the first floor, but with a slight difference. After laying "al'sherbak" as in step 5, overlapping mats of fibrous bark "leaf al'nakhl" were laid on top of it (see Fig 58). Then the base of the roof parapet was constructed by laying coral blocks on the peripheral walls of the house, with a thickness nearly half that of the walls. These bases were of about 0.5 - 1 ft high. "Al'Salby" was then spread on top of "leaf al'nakhl" with a suitable thickness forming the final roof layer. Builders spreading "al'salby" took into consideration the formation of ridges and valleys which lead to wooden gargoyles, thus maintaining efficient rain water evacuation of the roof.

7. The staircase

The staircase was constructed as a mass. Having a right-angled triangle cross-section and a rectangular plan. The steps were formed by the decreasing length of the coral blocks horizontal layers along the hypotenous (see Fig 60). The risers of the steps were determined by the the thickness of the coral block layers. The staircase of "bait al'sahel" usually consists of one flight

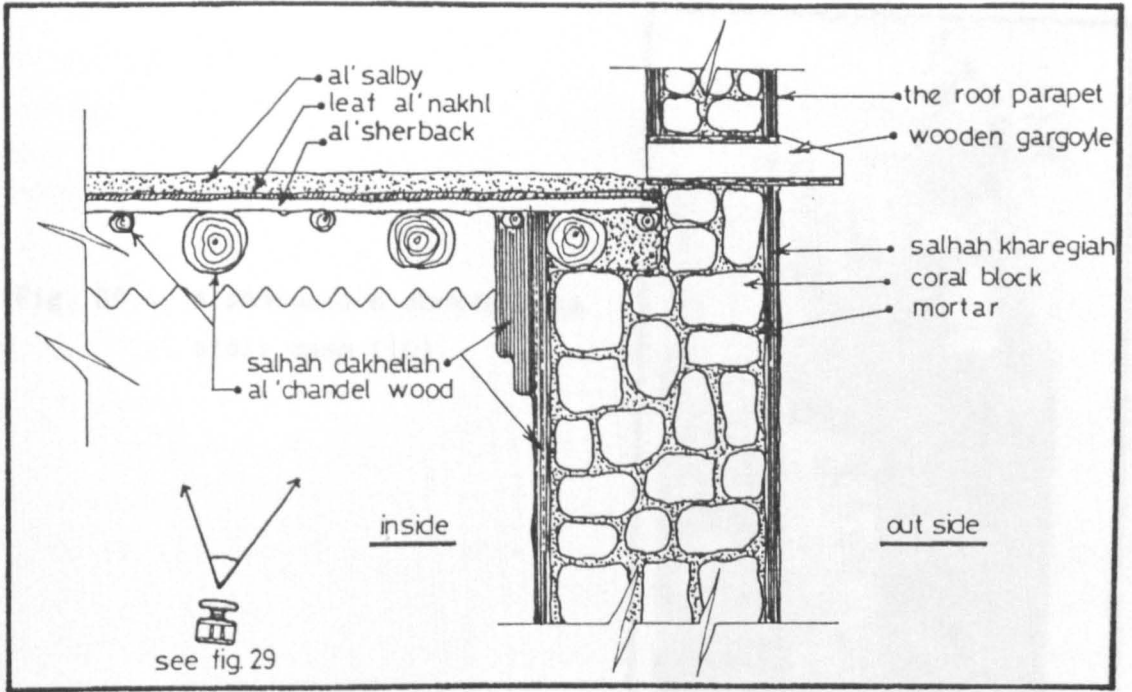

Fig. 58 : A sketch showing a section passing through the house final roof *

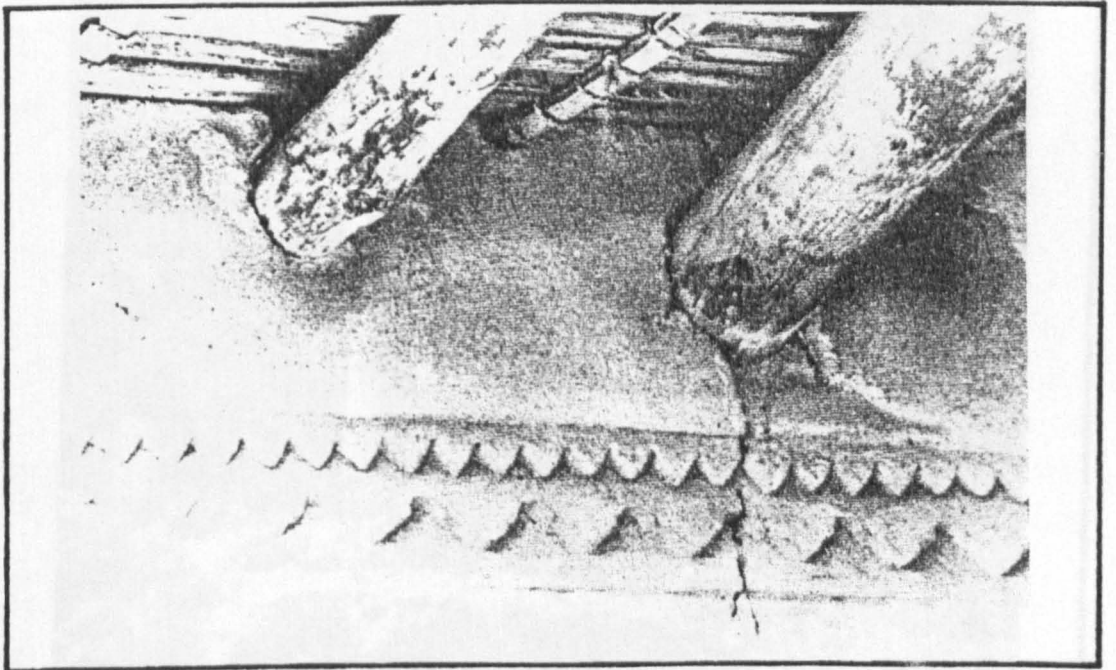

Fig. 59 : A photograph showing "al'chandel wood" trunks carrying the roof, and the "salhah dakheliah" on an internal wall (15).

Fig. 60 : A photograph showing the
stair case (10).

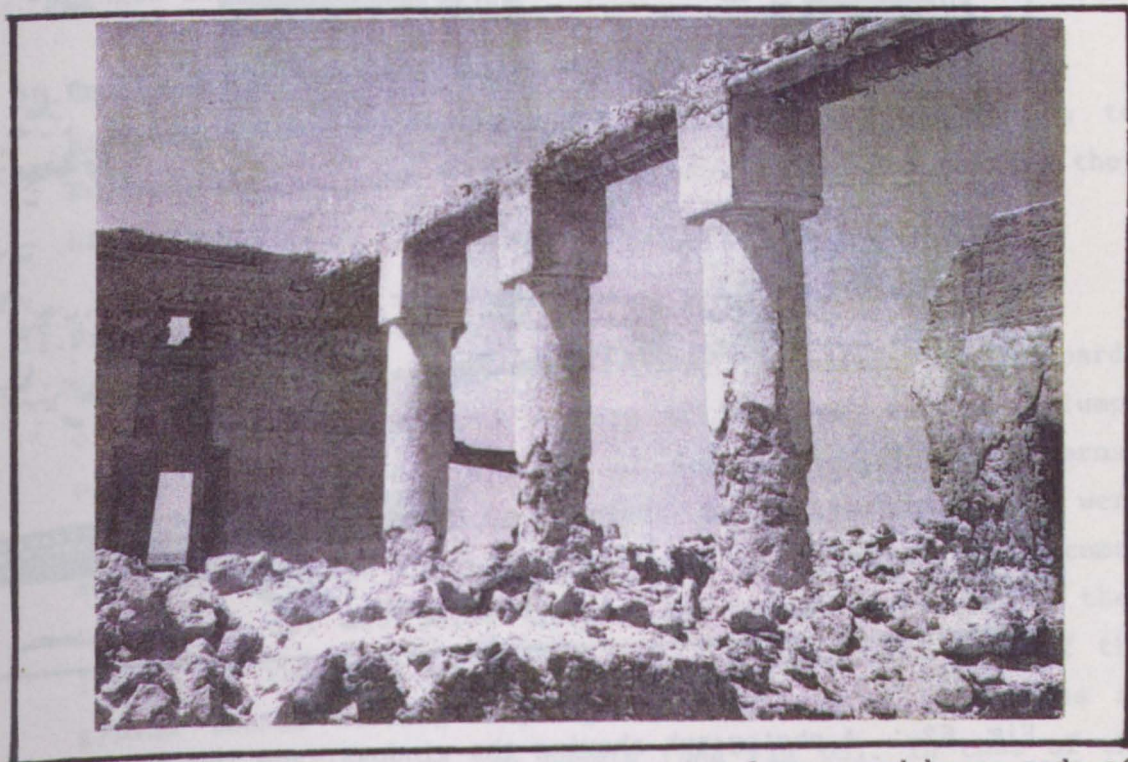

Fig. 61 : A photograph showing coral columns, and beams made of
"al'chandel wood" trunks (15).

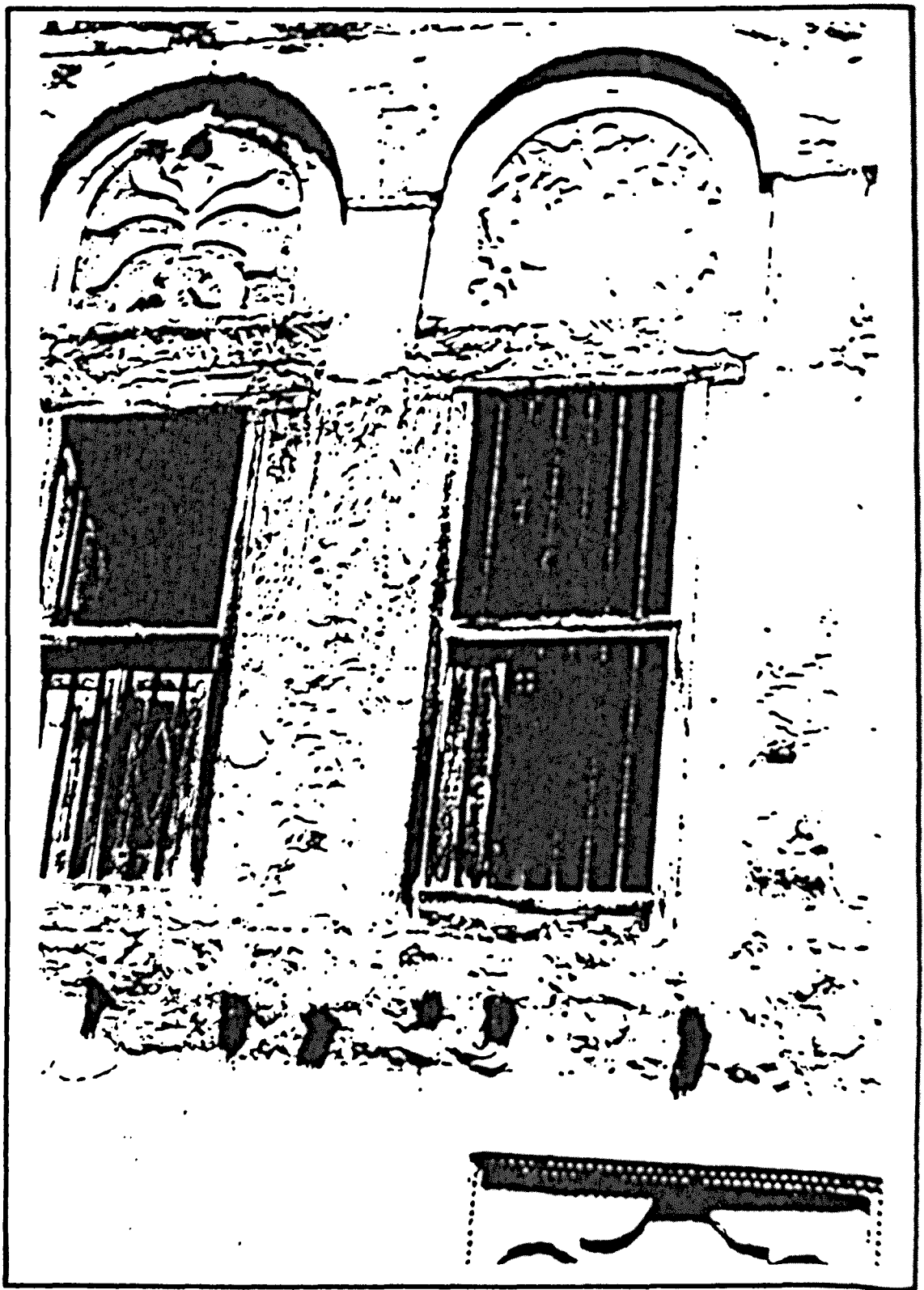

Fig. 62 : A photograph showing the windows, see the wooden shutters and the steel bars (16).

leading from the courtyard level to the first floor level.

8. The columns

The columns were constructed with various geometrical cross-sections. Square, rectangular and circular were the most common shapes. They were constructed with coral blocks and finished with plaster "slahah kharegiaah". They often had decorated caps (see Fig 61). Other types of columns were in wood with decorative engravings on their tops, which were mainly found in common buildings.

9. Doors and windows

Doors and windows were made of teak wood frames and shutters. The shutters were fixed to their frames by steel pins and hinges. Main and front doors were of decorative panels engraved on wood (see "bait al'sahel" Fig 35). Windows having wooden shutters were protected with vertical steel bars (see Fig 62). Other windows were protected with perforated gypsum boards of decorative patterns for both privacy, and climatical reasons (see Fig 66). Hinges and locks were in steel (see Fig 63).

10. Buttresses

Buttresses were the most sufficient and logical solution to support cracked walls. Built with coral blocks and mortar, they had a right angled triangle section (see Fig 64).

11. Parapets and sun screens

Parapets and sun screens were made of perforated gypsum boards of decorative patterns. A mixture of "al'yass" and small lumps of coral was poured in molds of desired decorative patterns. Shortly before the mixture dries, decorative engravings were sometimes added to the boards surfaces. After the mixture becomes completely dry and solid forming the gypsum board, it is then lifted of the mold to be fixed in its place. The line of the gypsum boards forming a parapet is interrupted by columns at an interval of one or two panels (see Fig 65). In case of the gypsum board being a sun screen, it was fixed in the wall opening

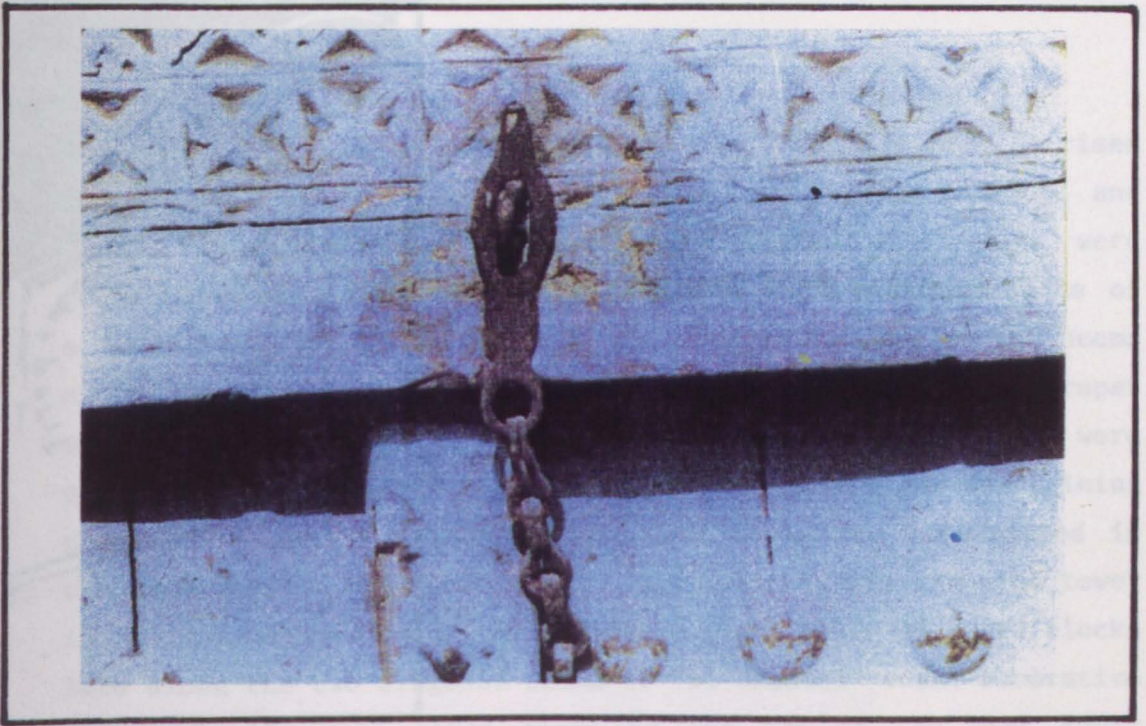

Fig. 63 : A photograph showing the steel chain lock; an internal view of a main door (17).



Fig. 64 : A photograph showing the buttresses constructed to support a cracked wall (15).

Fig. 65 : A photograph showing a part
of a roof parapet (16).

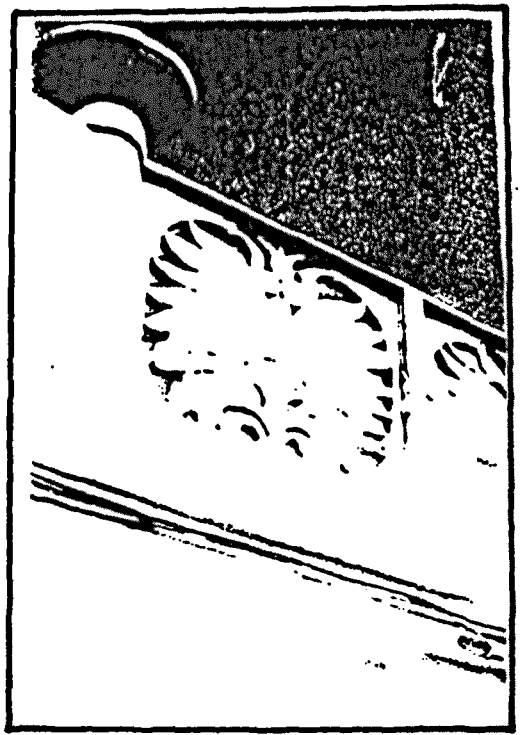
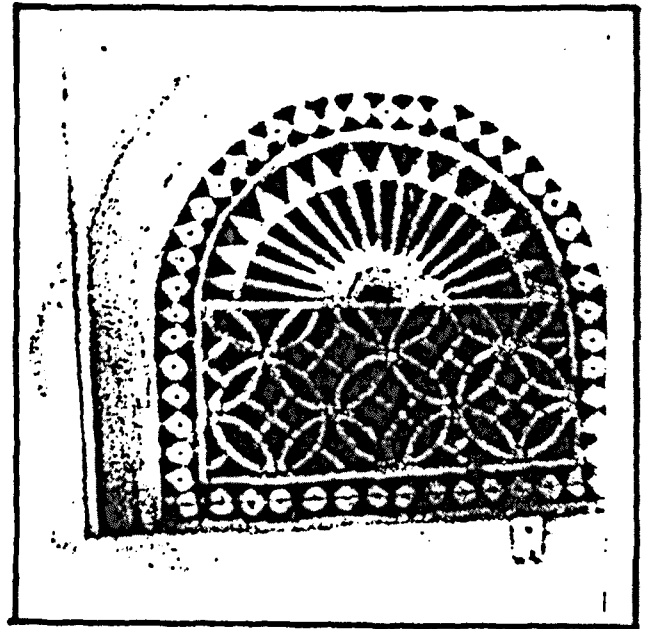

Fig. 66 : A photograph showing one of the
window gypsum sun-
brakers (16).



with mortar (see Fig 66).

12. The wind tower

The wind tower was usually of square plan (see Fig 67). It rises about 45 ft above ground level. It is closed from the top, and opened from the four sides and the bottom. The sides were constructed by coral columns and linked with solid parapets of a height nearly $\frac{1}{4}$ of that of the wind tower. Horizontal beams of "al'chandel" wood were laid on the four sides above the parapet every $\frac{1}{4}$ of the total height left of the openings. They were a simple form of permanent scaffolding for cleaning and maintaining the wind tower. The roof of the wind tower was constructed in the same way as the house roof. The volume inside the wind tower is divided vertically by four concave inner walls of coral blocks laid along the two diagonal beams of "al'chandel" wood. Decorative gypsum boards were often fixed to the top of the wind tower openings for esthetical reasons.

13. Finishes

After the construction of "bait al'sahel" had been completed, the exterior and interior walls were finished with plaster - "salhah". Exterior plaster - "salhah kharegiah" for exterior wall surfaces and columns, and interior plaster - "salhah dakheliah" for interior wall surfaces (see Fig 61).

Conclusion

The process of constructing "bait al'sahel" utilised natural building materials. These materials were either extracted from natural sources in the local environment or imported from neighbouring or remote similar environments. These building materials were adequate for the adaptation with the surrounding environment. The traditional building knowledge, a combination of both the wall-bearing system (see Fig 52) and the beam-column system (see Fig 61), was transferred consecutively from one generation to the other of skilled builders. This knowledge helped builders assembling the natural building

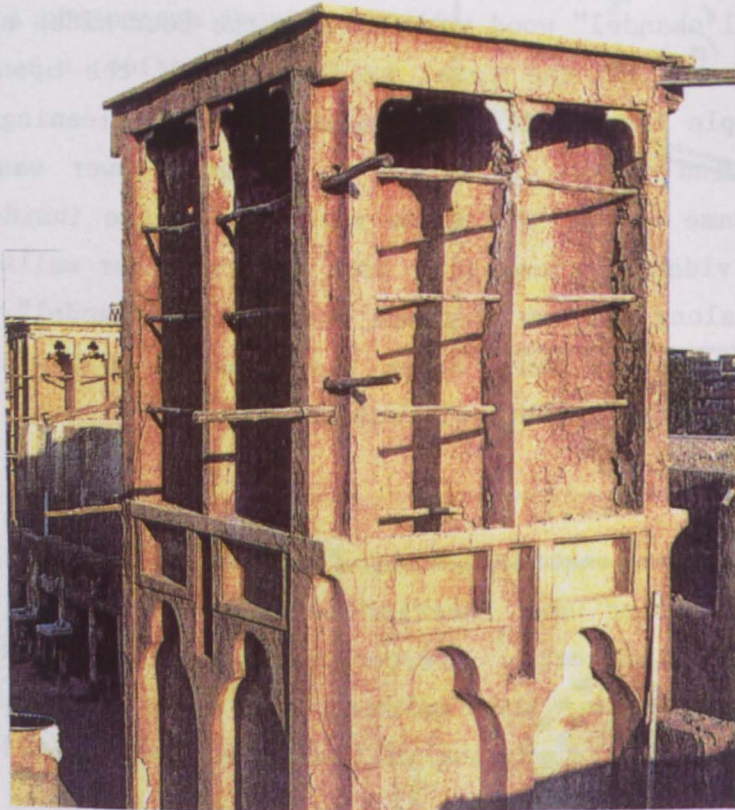

Fig 67 : A photograph showing the wind tower (18).

materials together in different ways and with different methods to construct the house different details.

Environmental Aspect

The local builders of "bait al'sahel" not only knew how to achieve the functional, social and technical requirements but also knew how to minimise the discomforts of their local climate. Considering the very high temperature degrees and the humidity rates that sometimes reaches saturation (see Climatological cond.), the house of "bait al'sahel" was a remarkable example on the successful adaptation to such severe environmental conditions. The consecutively transformed building knowledge, from one generation of skilled builders to the other, included the following environmental considerations :

1. The shape and orientation of buildings.
2. Summer and winter floors.
3. Natural ventilation.
4. Sun protection.

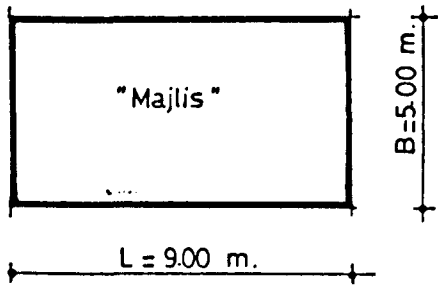

Fig. 68(a) : $R = 1 : 1.8$

-----[1]

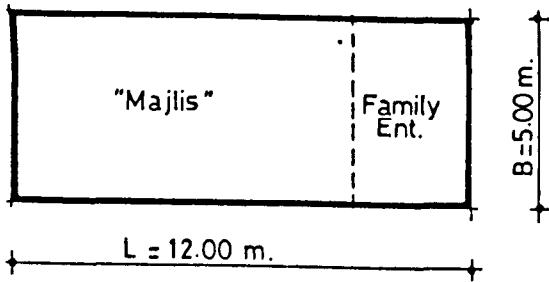

Fig. 68(b) : $R = 1 : 2.4$

-----[2]

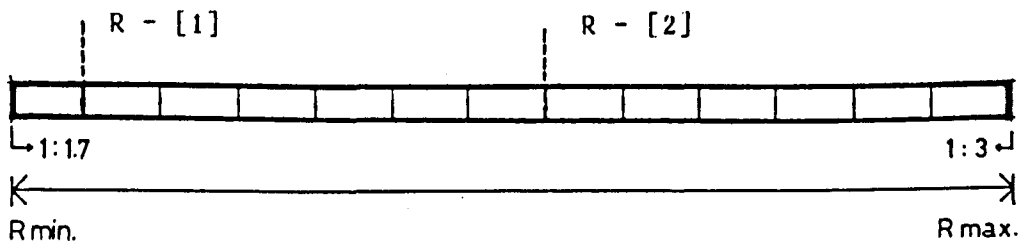

Fig. 68(c) : The range of the ratio "R" of buildings in hot & humid climates.

1. The shape and orientation of buildings

The shape

The shape of the buildings of "bait al'sahel" was usually of rectangular layout (see Fig 33).

Calculating the ratio of the breadth to the length of the approximately rectangular layout of the "al'majlis" of "bait al'sahel" shown in figure 33, the following results were found:

* neglecting the unroofed family entrance (see Fig 68a):

$$L \text{ (length)} = 9.00 \text{ m.}$$

$$B \text{ (breadth)} = 5.00 \text{ m.}$$

$$R \text{ (ratio)} = 1 : (L/B)$$

$$= 1 : (9.00 / 5.00)$$

$$R = 1 : 1.8 \text{ ----- (1)}$$

* considering a roofed family entrance (see Fig 68b):

$$L \text{ (length)} = 9.00 + 3.00 = 12.00\text{m.}$$

$$B \text{ (breadth)} = 5.00 \text{ m.}$$

$$R \text{ (ratio)} = 1 : (L/B)$$

$$= 1 : (12.00 / 5.00)$$

$$R = 1 : 2.4 \text{ ----- (2)}$$

* Both values of "R" found in (1) & (2) lie in the range between the minimum and the maximum values of "R" of rectangular layout of a building in hot and humid climates (19) (see Fig 68c), where:

$$R \text{ max.} = 1 : 1.7$$

$$R \text{ min.} = 1 : 3.0$$

The roofs of the buildings were always of horizontal and flat surfaces (see Fig 38). Hence, minimising the roof surface area directly exposed to the sun all day time (see Fig 69).

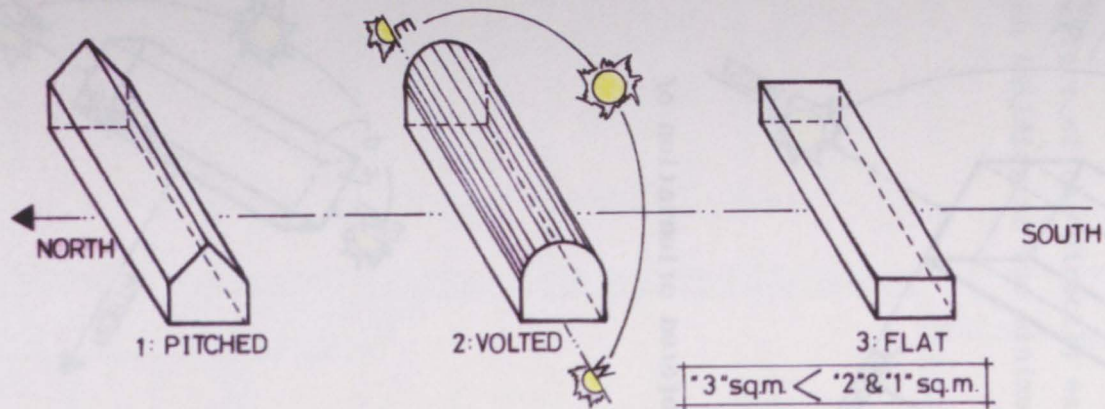

Fig. 69 : A sketch showing the effect of the roof type on the roof surface area exposed directly to the sun.

Comment : In spite of the potential minimisation of the impact of the sun radiation on vaulted roofs, flat roofs are still preferred for utility reasons.

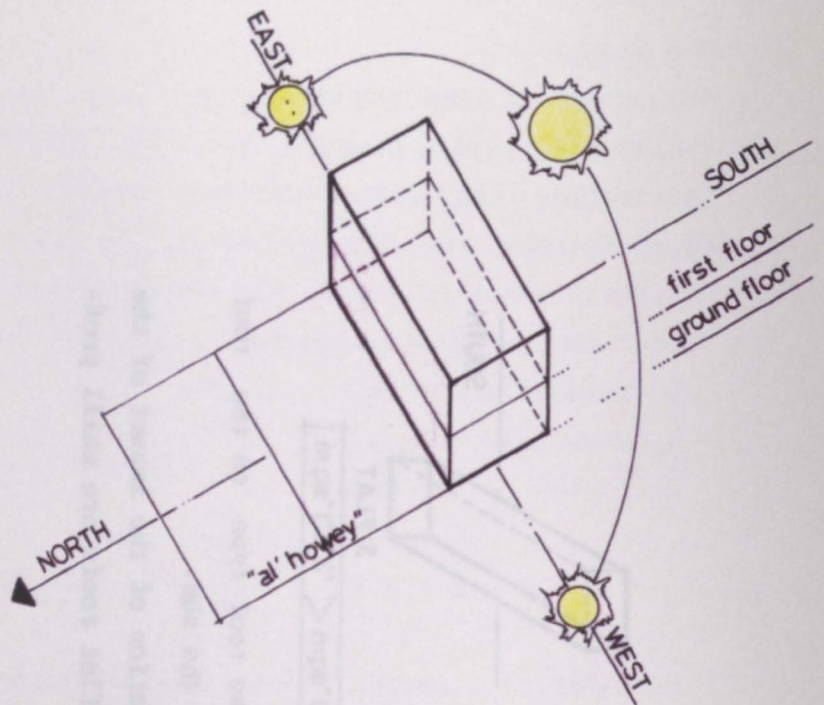

Fig. 70 : A sketch showing the preferred orientation of "bait al sahel".

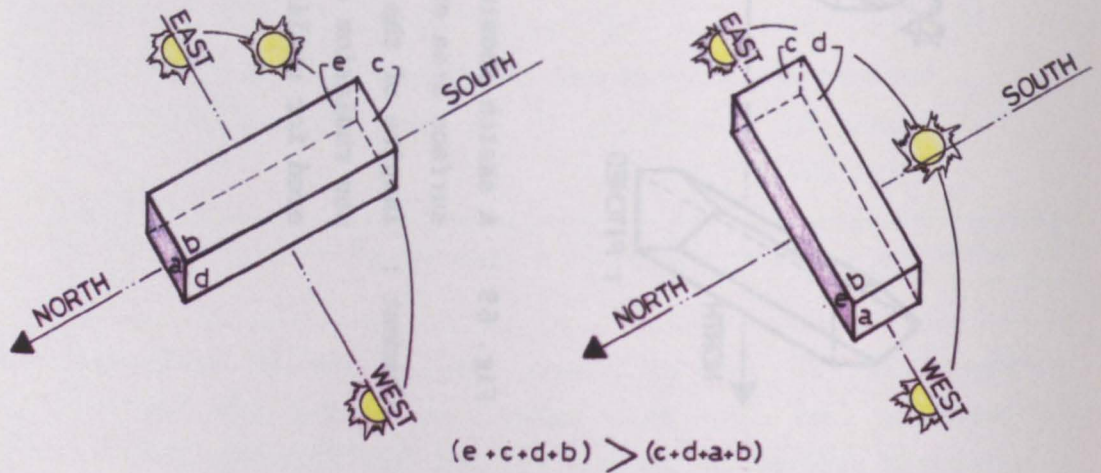

Fig. 71 : A sketch showing the effect of the orientation on the total exterior surface area of the building exposed directly to the sun.

The orientation

The orientation of "bait al'sahel", facing north to north-west, allows its building and its outdoor spaces to benefit from the morning sun. A considerable shaded area is obtained during the afternoon period of the day (see Fig 70). Having the breadth of the rectangular layout facing the east and the west directions, resulted in exposing the minimum exterior walls surface areas of the building to the direct sun rays (see Fig 71). Thus reducing the effect of the directly exerted heat load on the exterior surfaces of the building to the minimum.

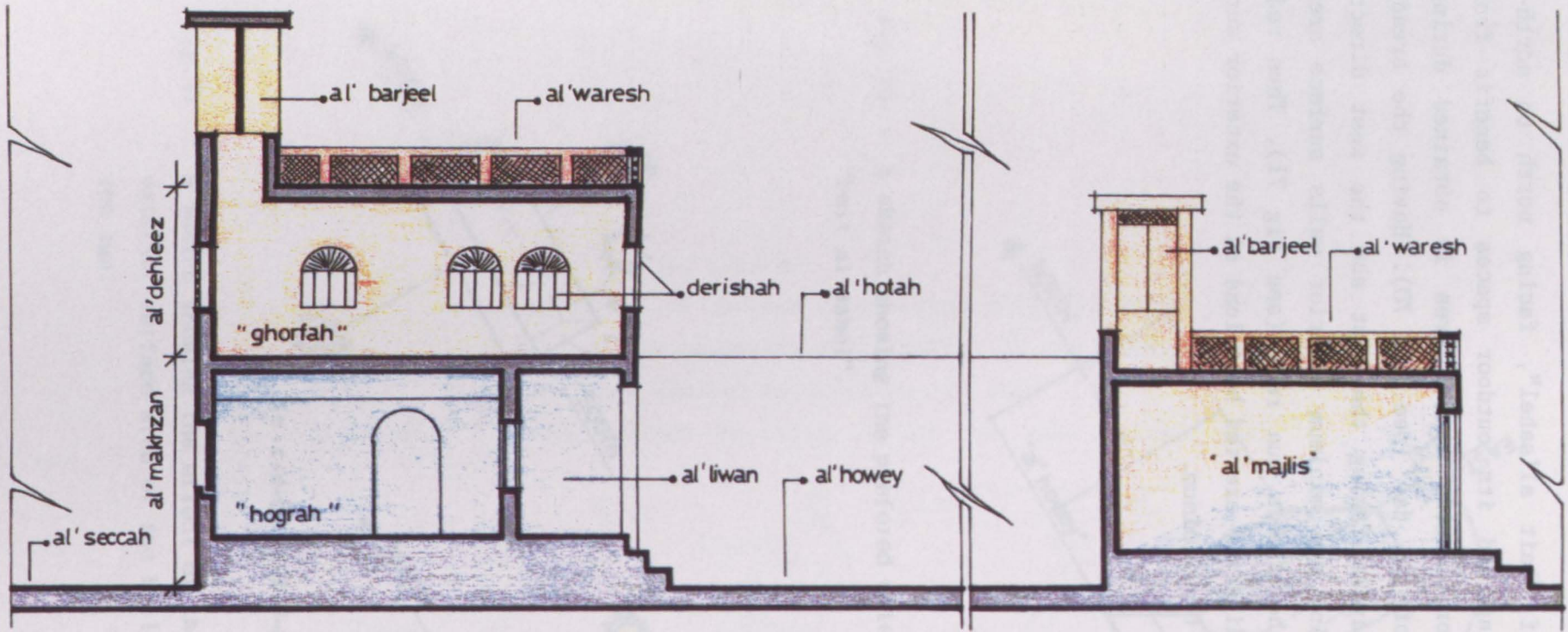

Fig. 72 : A sketch showing the winter & the summer floors.

Key:



winter floor



summer floor



"al'majlis" : is used in both winter and summer seasons.

2. Summer and winter floors

The family/women's zone of "bait al'sahel" consists of two floors; "al'makhzan" and "al'dehleez". Each of these two floors is used by the households in a different season (see Fig 72). Thus the family / women's zone was divided into two seasonal floors, which are as follow:

The winter floor

The winter floor is the ground floor of the family / women's zone; "al'makhzan". It contains "al'hogar" and "al'liwan". "Al'Hogar" being used in winter had almost three solid walls, except from that facing north which had two to four windows for each room placed simetrically on both sides of the entrance door. This helped preserving the room temperature and maintaining a controlled natural ventilation when desired (see natural ventilation - the breathing walls). "Al'Liwan" being a semi-enclosed transitional space between the courtyard "al'howey" and the family rooms "al'hogar" (see Fig 36), protected the only side of the rooms having windows from direct sun rays and occasional winter rains. Being protected from the south by the family rooms and the west by a solid wall and from the top by "al'dehleez" (see Fig 38), "al'liwan" became an ideal protected space to benefit from the morning winter sun. Having a perforated parapet of 3 - 4 ft high helped channelling a desirable low level air draft.

The summer floor

The summer floor is the first floor of the family / women's zone, "al'dehleez", containing the family rooms "al'ghoraf". They are the family rooms used in summer for various reasons, which are:

- * Having the same roof height as those on the ground floor but of larger surface area, they allowed the households to benefit from a bigger volume. Where the surface area of the first floor rooms equal these of the ground floor plus the "al'liwan" surface area. This bigger volume helped increasing the time needed to heat up the indoor air volume of "al'ghoraf".
- * Being on a higher level above the ground allowed the builders

to open windows all around the rooms "al'ghoraf". Thus they can benefit from the cool prevailing summer winds without affecting any other essential requirement such as privacy (see Fig 47).

- * "Al'Barjeel", the wind tower, being placed on top of the family rooms "al'ghoraf" benefits from the cool high circulating prevailing winds. Thus avoiding the heated air layers close to the ground level.
- * Being on a high level, "al'ghoraf" were protected from the reflected ground glare.

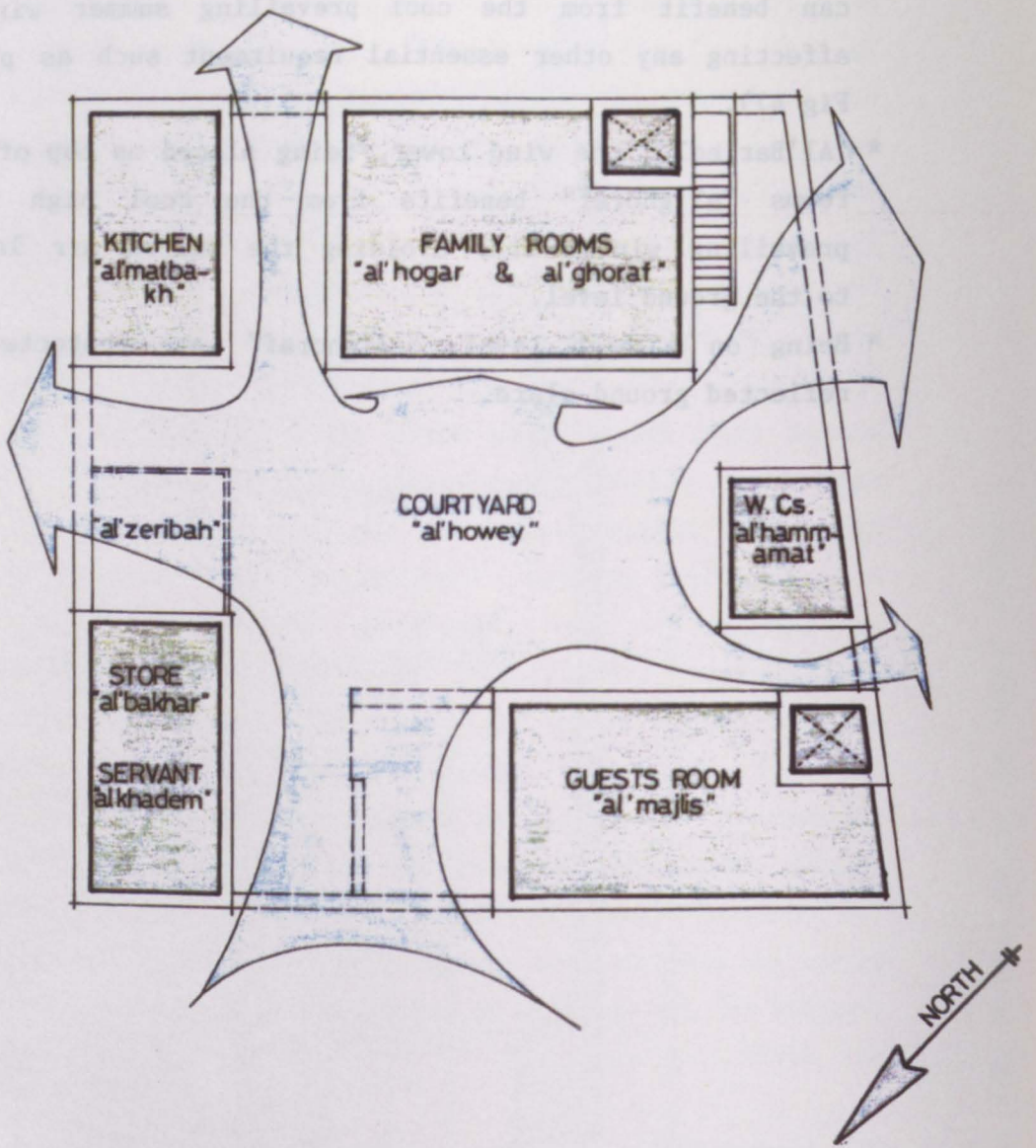

Fig. 73 : A sketch showing the air channelling of the prevailing winds inside the courtyard and around the buildings of "bait al'sahel".

Key :



The summer prevailing winds.

3. Natural ventilation

Due to the severe climatic conditions of the local environment, natural ventilation became a vital parameter of design that needed to be controlled. Thus achieving the most comfortable conditions inside and outside the house buildings both in summer and winter. The house being built around a semi-enclosed courtyard facing north to north-west, created efficient air channelling of cool north to north-west summer prevailing wind around the house buildings (see Fig 73). This air channelling provides continuous cooling effect for all the house external surfaces. It also prevents the accumulation of the hot and humid still air in the courtyard. Thus reducing the feeling of heat and humidity, and creating more comfortable conditions.

Three different natural ventilation systems were applied in the house of "bait al'sahel", in order to benefit from the cool winds channelled around the house in different seasons. These systems can not replace one another. Each system was designed to maintain natural ventilation in certain spaces of the house, that is depending on the space type and the season in which it was occupied. Taking into consideration that natural ventilation should be achieved without affecting any other requirement such as privacy (see Fig 47). The three natural ventilation systems are:

- * The breathing walls
- * The wind tower "al'barjeel"
- * The cross ventilation

The breathing walls

The breathing walls system was applied in the family rooms on the ground floor. This system consists of two vertical windows and two horizontal narrow openings. The two windows were placed on the wall facing north to north-west, overlooking the courtyard. The two horizontal openings were placed on the opposite wall across the room, facing south to south-east. The two narrow openings were at the same level as the windows sills (see Fig 74). The length of each is equal to the width of the window (see Fig 36). When the

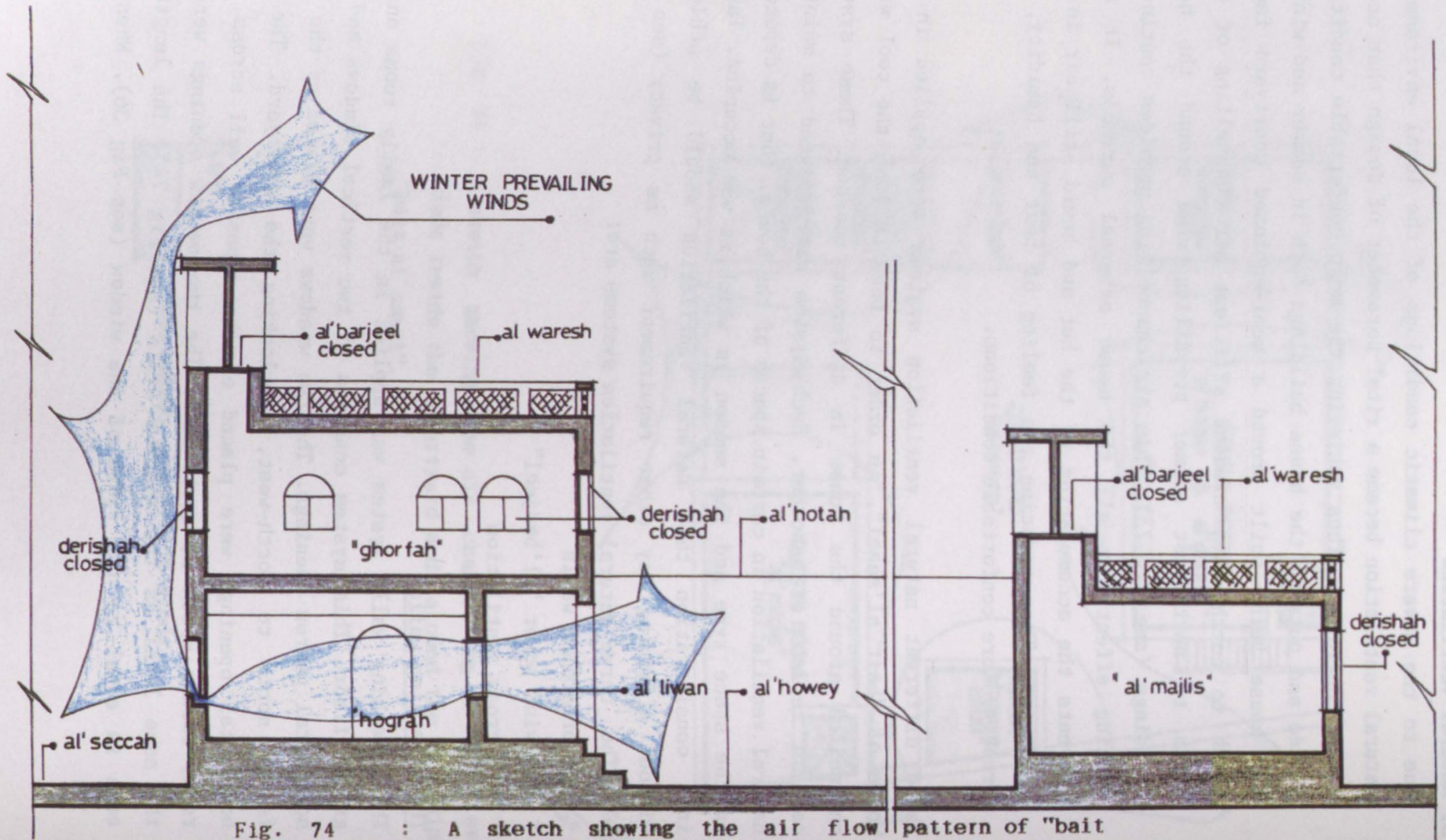

Fig. 74 : A sketch showing the air flow pattern of "bait al'sahel" in winter.

low speed winter prevailing winds blow, the two narrow openings act as air inlets and the windows act as air outlets. Thus accelerating the entering air and achieving continuous natural ventilation. When the prevailing winds are loaded with dust and fine sand grains, the narrow openings are closed with pieces of wood. Thus preventing the dusty winds from entering through, and also the accumulation of sand and dust from blocking the openings. The location of both windows and the narrow openings in their corresponding locations serves the purpose of privacy.

The wind tower "al'Barjeel"

"Al'Barjeel" is the local name of the wind tower. It is used to maintain natural ventilation in the hot and humid summer time. It is found on top of the family rooms on the first floor level of the house, and also on top of the guests reception "al'majlis" (see Fig 72). These family rooms being only used in summer, and the guests reception in both summer and winter required closing the wind tower in winter time (see Fig 74). The wind tower acts as a complete thermal chimney (see Fig 75); up draft, down draft and wind collector. This is explained as follow:

Up draft

During the day time when the temperature degree reaches its maximum value, the wind tower helps releasing the hot air inside the rooms which is also known as the stack effect.

Down draft

After sun set and during the night the temperature degree reaches its minimum value, and due to the large diurnal temperature difference between the day and the night, a cold draft is generated from the outside and through the wind tower into the interior space.

Wind collector

The wind tower was designed to collect the cool summer wind as soon as it blows from any direction. The wind tower being divided into four thermal chimneys allowed to benefit from the cool wind at any time of the day without affecting any of the two other ventilation systems already in function.

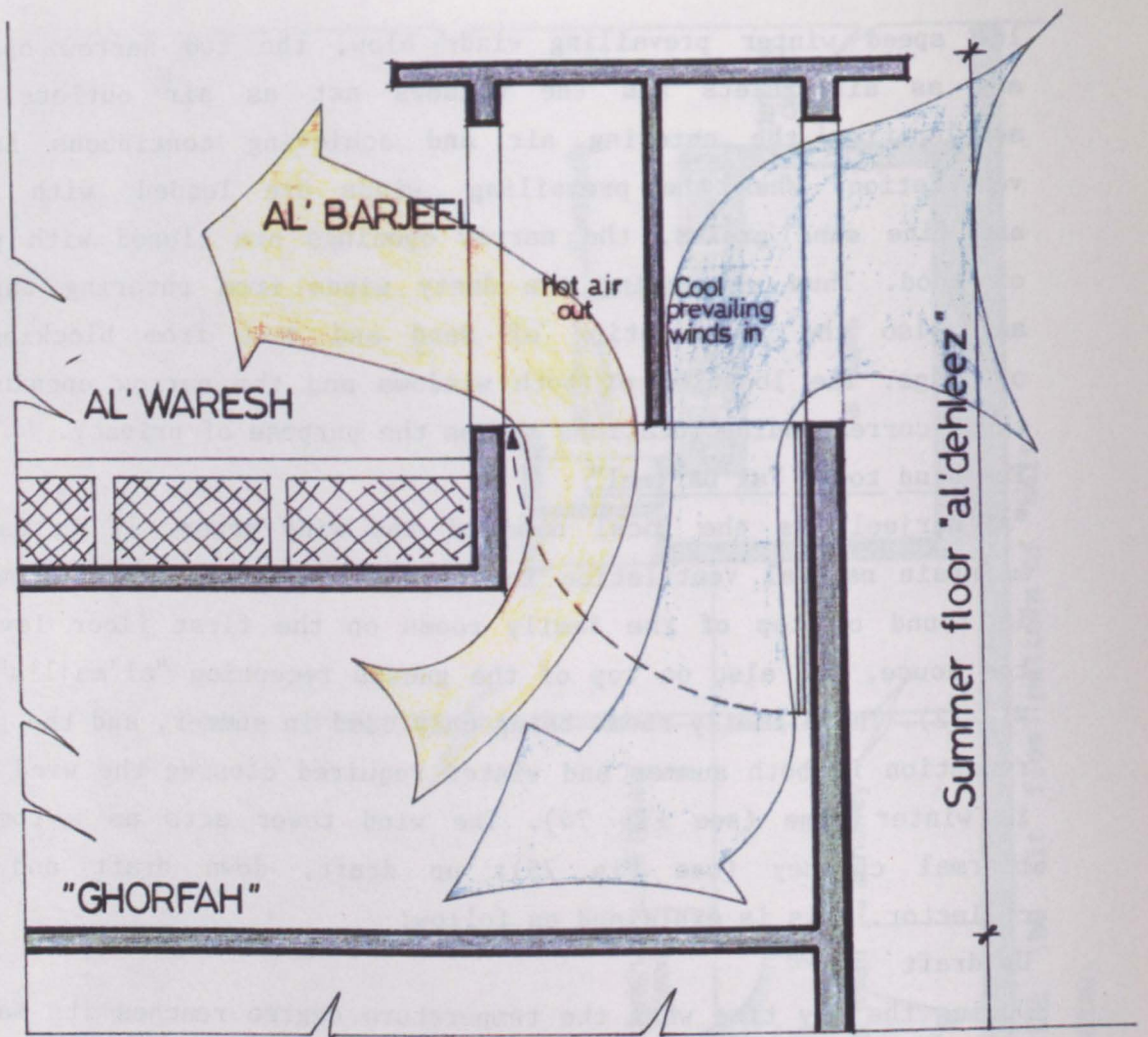

SECTION

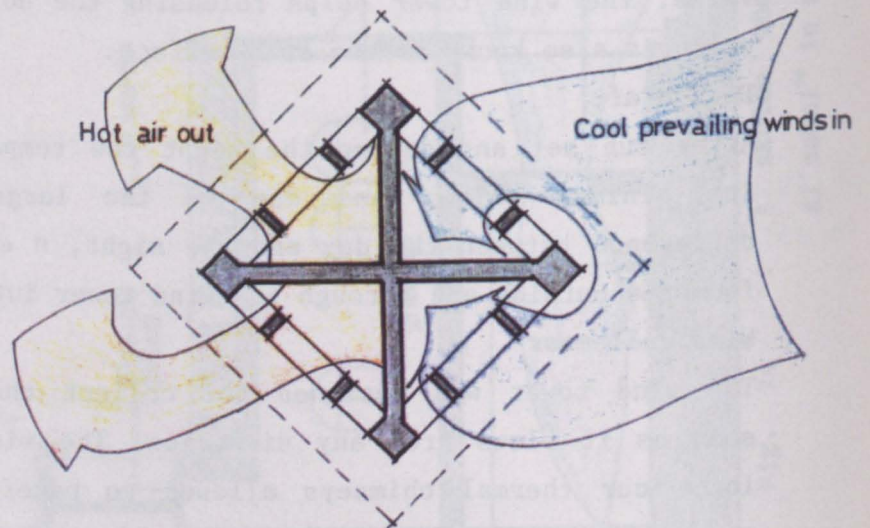

PLAN

Fig. 75 : A sketch showing natural ventilation achieved using "al'barjeel" in the family rooms "al'ghoraf" of the summer floor "al'dehleez".

Natural cross ventilation

The air flow pattern generated by natural cross ventilation varies from one space to the other in the house. Four different air flow patterns can be distinguished as follow:

In the family rooms

Natural cross ventilation in the family rooms on the first floor was achieved by placing windows on the walls facing the prevailing winds, and other windows on the opposite walls across the room. Due to the steadiness of the desirable prevailing winds, windows acting as air outlets or inlets were of equal size (20). Windows were located at a medium height, thus providing desirable air flow across the room (see Fig 76). Windows overlooking the courtyard of the house did not need any visual protection, while those overlooking the street were protected by perforated gypsum boards. Thus maintaining natural cross ventilation and providing visual protection from outside of the house (see Fig 47).

In the kitchen

Due to the applied conventional way of cooking using the traditional furnace, cross ventilation in the kitchen was controlled. This was to reduce the air velocity inside the kitchen and maintain continuous low speed air flow for smoke and odour removal. This was achieved by placing medium height air inlets of a large size on the walls facing prevailing winds, and high levelled narrow openings acting as outlets on the opposite walls across the room (see Fig 77). A narrow opening is called "al'Quemry" and it is usually of circular or square shape (see Fig 78).

In the toilets

In the toilets, cross ventilation was also controlled in order to accelerate the air velocity inside them. Thus maintaining a continuous, rapid air flow for odour removal. This was achieved by using the narrow high leveled openings "al'quemry" as air inlets, and the door as air outlet. Where the toilet door was always kept open when it was vacant.

On top of the roof

The roof parapet made of perforated gypsum boards helped channelling the cool prevailing winds as close as possible to the roof level.

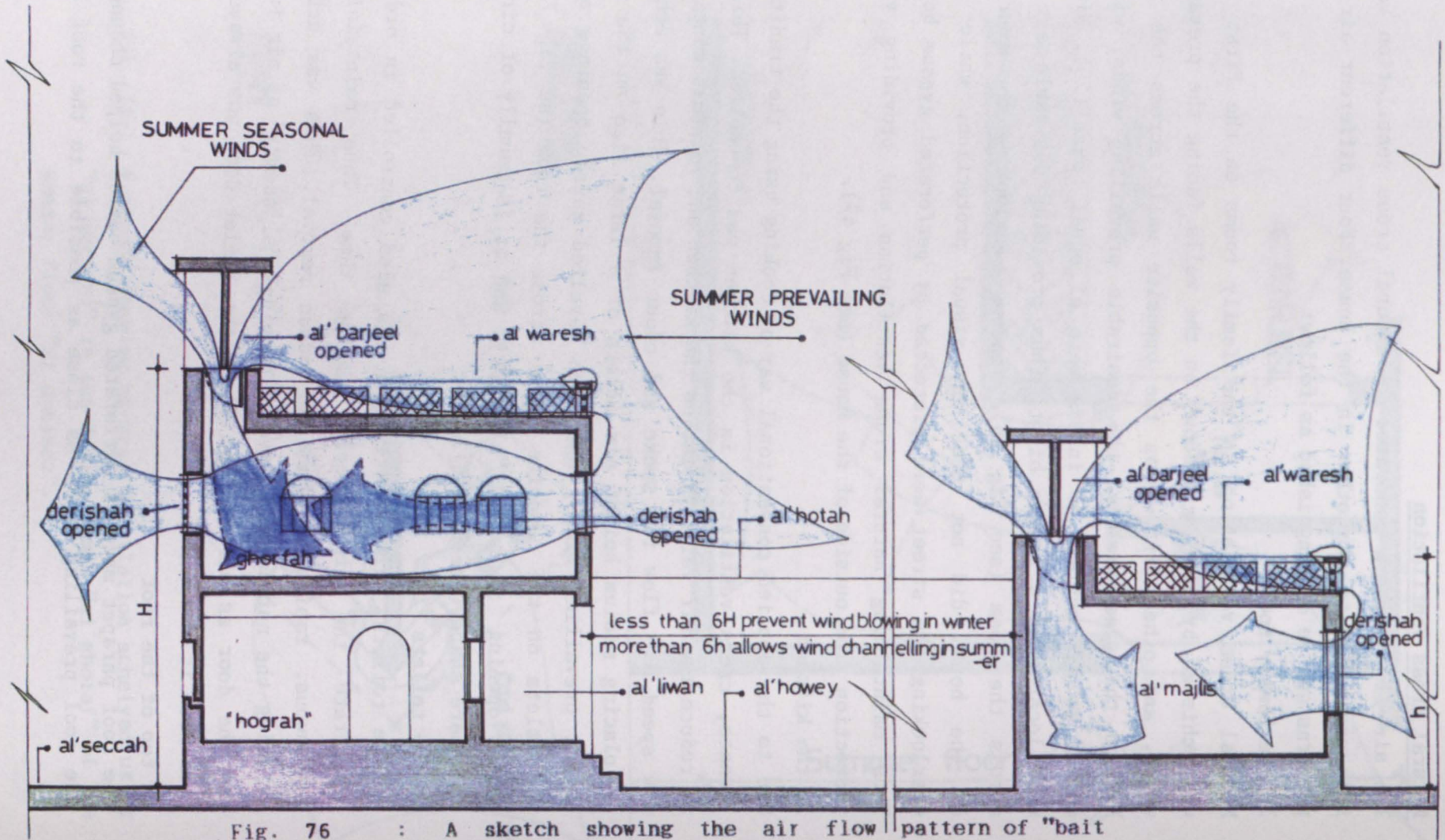

Fig. 76 : A sketch showing the air flow pattern of "bait al sahel" in summer.

Thus maintaining continuous cooling of the roof surface which is exposed all the day time to sun rays (see Fig 76).

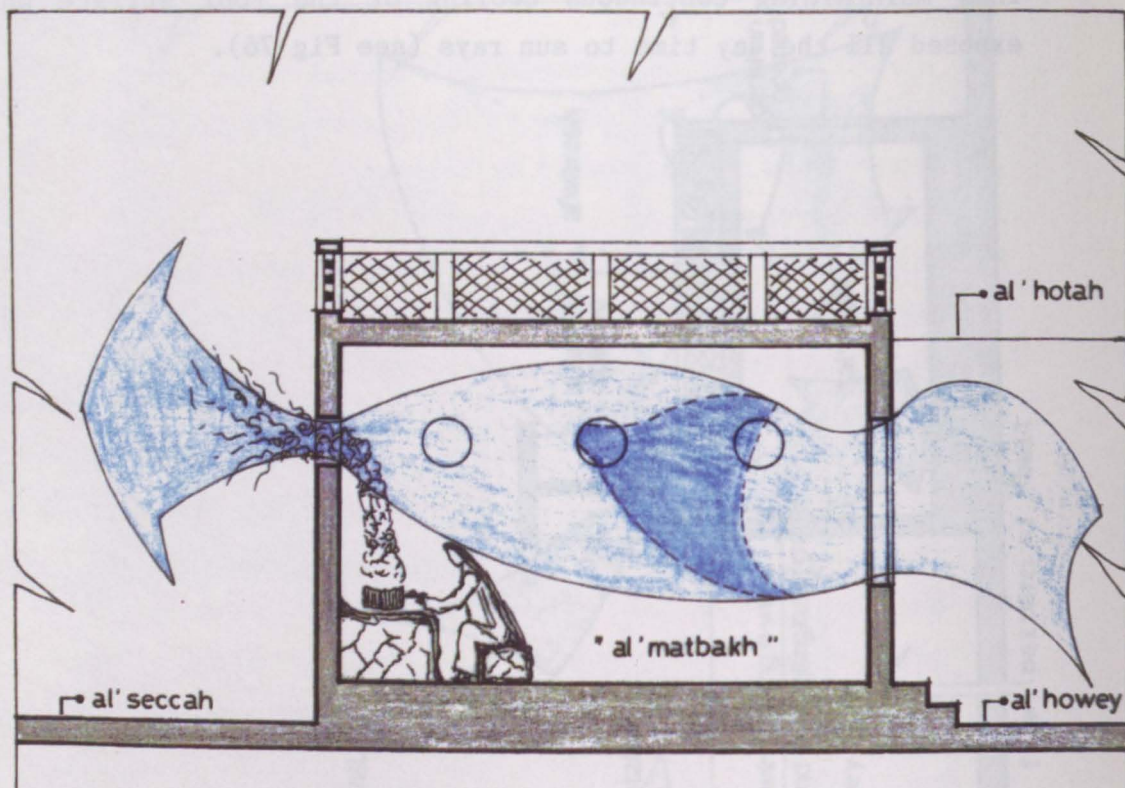

Fig. 77 : A sketch showing the air flow pattern in the kitchen "al' matbakh" using "al' quemry".

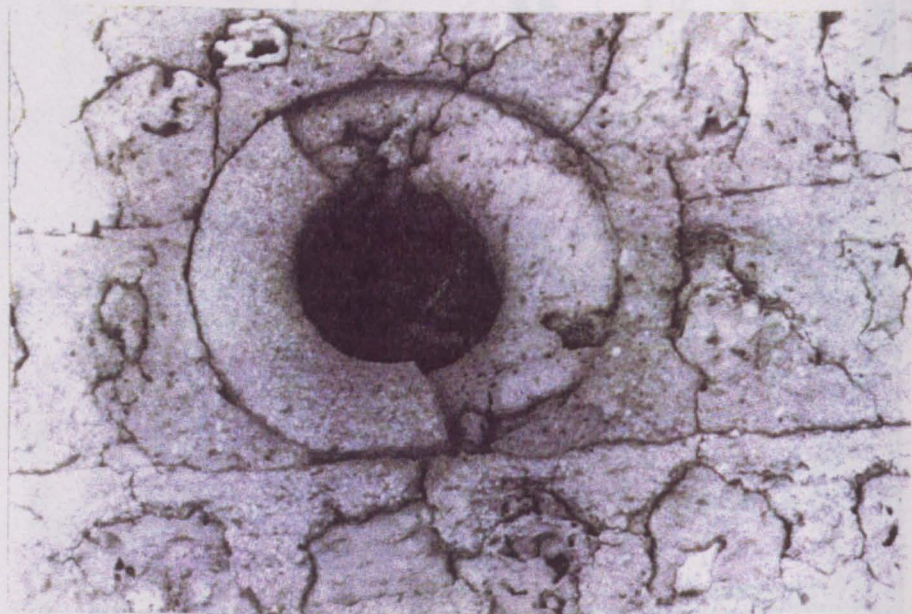

Fig. 78 : A photograph showing "al' quemry" (15).

4. Sun protection

Sun protection is highly required for the constituents of the house of "bait al'sahel" during the summer season. The sun protection of the house was achieved by the following:

- * The house was divided into separate buildings according to their different functions surrounding an outdoor space. This separation provided numerous shaded outdoor areas, and shade for the exterior walls of the house.
- * The building materials used in the construction of the house were bad heat conductors, such as the coral blocks which are light in colour and of low density. The use of "al'chandel" wood in the roof construction as it is a bad heat conductor. The use of fibrous bark within the roof layers as thermal insulator.
- * All exterior finishes of the house walls were of light colours. Thus reflecting the most of the direct sun rays, and the glare of the surrounding ground area.
- * The southern windows were protected by perforated gypsum boards of light colours. Thus protecting the inside from the sky glare and direct sun rays, without hindering the free air movement inside the rooms.
- * The wall thicknesses ranges from 1.5 - 2 ft (see Fig 50). This helps delaying and reducing the heat transfer from outside the house to the inside providing the bad heat conductivity of the walls and their light colours (see Fig 79).
- * The windows are deep and of vertical direction (see Fig 62). Being deep (see Fig 80) and vertical reduced the period of direct sun light passing through them during the day time. The windows having a vertical rectangular shape provided indirect sun light all through the day.
- * Usually one or more palm trees were planted in the courtyard of the house. These palm trees providing considerable shaded outdoor areas, reduced the courtyard area directly exposed to the sun. Thus reducing the reflected ground glare and the heat absorbed during the day. Palm trees also provide an evap-transpiration cooling effect which helps reducing the

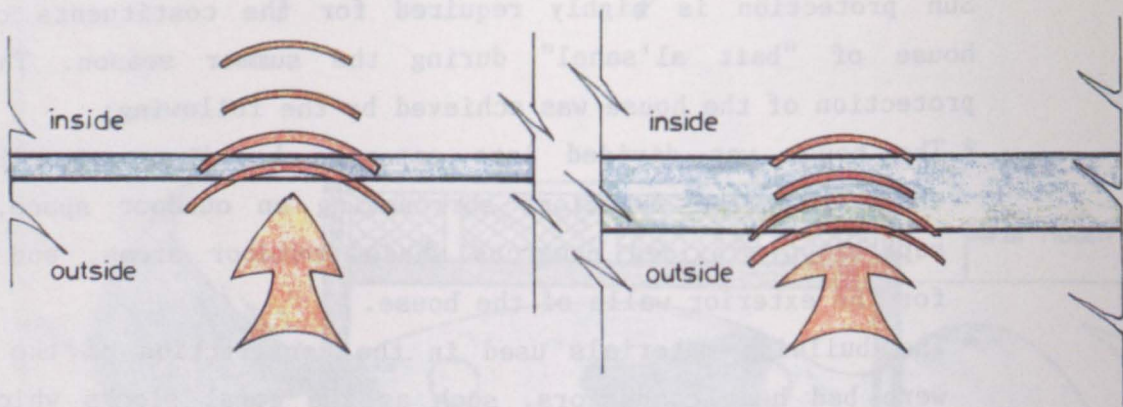
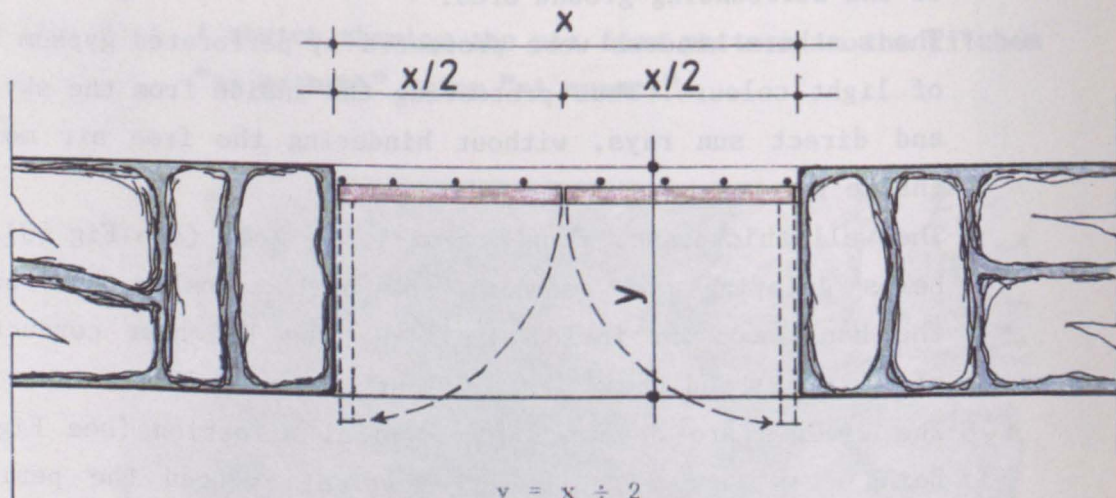

Fig. 79 : A sketch showing the effect of the wall thickness on the heat transfer from outside to inside the house.



$$y = x \div 2$$

$$x = 2 \times y$$

$$y = 1.5 - 2 \text{ ft.}$$

$$x = 3 - 4 \text{ ft.}$$

where : y : the wall thickness = the depth of the window

x : the window width = 2 × the wall thickness

= 2 × the depth of the window

Fig 80 : A sketch showing the relation between the depth & width of the window, and the wall thickness of the house of "bait al' sahel"

ambient temperature of the courtyard. They also form an efficient dust and sand filters.

Conclusion

The previous study shows that the constituents of the house of "bait al'sahel" are either of rectangular or trapezoidal shapes. These shapes having the proper orientation reduces the exterior surface areas of the house exposed to direct sun light. The differentiation between the periods of usage of the ground and the first floors of the family / women's zone, where the ground floor was used in winter and the first floor was used in summer. The natural ventilation systems; simple ideas which function in harmony without affecting each others role. Finally, sun protection elements which have more complete function than being simply sun screens, but serving privacy and decoration at the same time. These are the main characteristics which offered the households of "bait al'sahel" persistent indoor comfortable environmental conditions.



Fig. 81 : A sketch that shows how "Biute al'Burr" are laid out together (21).

b) Biute al'Burr

Biute al'Burr are the traditional houses of the local people built on Abu Dhabi's main land. They are locally called "Biute al'Leban", where the term "al'Leban" is the local name of the mud paste used in making the mud-bricks. Thus "Biute al'Leban" means the mud-brick houses. They are built attached to each other forming multi-dwelling unit family compounds. Most of the houses forming these compounds are small. They are often of one or two family rooms only, although the same extended family might own several such houses grouped together. These extended family compounds are of irregular forms. This irregularity of forms generates a complex pattern of streets visually impermeable to strangers, and helps channelling air between the houses (see Fig. 81). This tendency towards creating self-confined groups of houses resulted in a chain of piazzas linked together by a network of divergent passage ways between the houses (see Biute al'Sahel for the piazzas, streets equivalent local names). It also resulted in several chains of interlinking private courtyards belonging to different families.

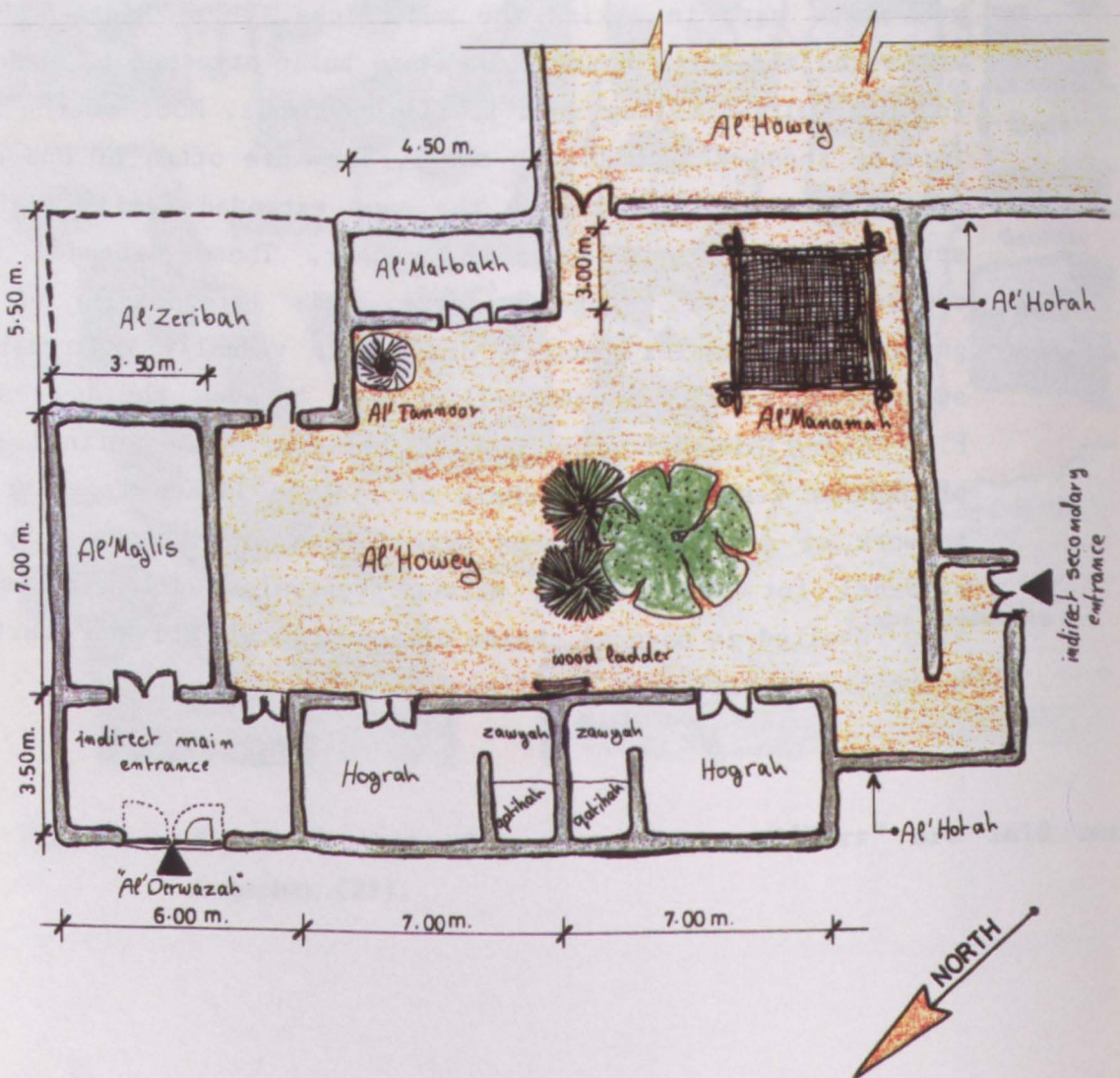

Fig. 82 : An example for "Bait al'Leban" - the mud-brick house (22).

Note : This drawing is not to scale; dimensions shown are approximated.

An example for one of "Biute al'Leban" is shown in figure 82. "Biute al'Leban" are generally divided into three main zones (see Fig. 83), which are:

- 1) Family / women's zone
- 2) Guests / men's zone
- 3) Services zone

These three zones are built around an open space called "Howey" (see Fig. 82). The area of "al'Howey" is confined by the fragmented elements of the house and the boundary walls, "al'Hotah", linking them together. The house has two indirect entrances. The main indirect entrance, "al'Derwazah" is used by the family and the guests alternatively. It is similar to that of "Bait al'Sahel". The secondary indirect entrance is exclusively used by family members, especially women when the family males are receiving their guests.

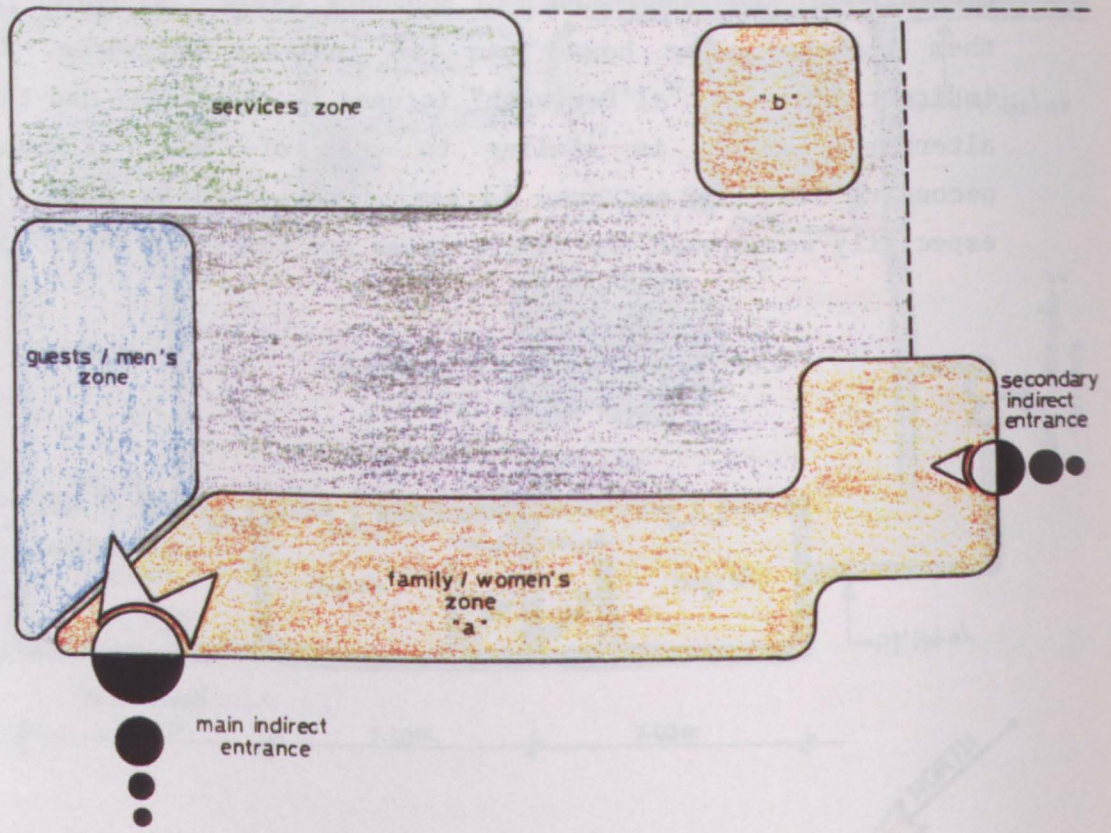

Fig. 83 : A diagram that shows the different zones of "Bait al'Leban".

Each zone of this type of house, "Bait al'Leban", consists of one or number of multi-functional spaces, which are as follow:

1) Family / women's zone

The family / women's zone consists of the family living rooms, locally called "al'Hogar" (see Bait al'Sahel for the definition of al'Hogar). Each "Hograh" consists of three confined areas (see Fig. 82): a main area for sleeping, sitting, dinning and coffe making; a dressing area called "Zawiah"; a bathing and ablution area called "Qatihah". The "Hogar" are built on a solid platform raised above the courtyard level by one or two steps. They have rectangular shapes with their breadths facing the courtyard, where they are dierectly accessible through wooden double doors. The number of "Al'Hogar" in most of "Biute al'Leban" usually does not exceed two or three, where an adult son can add a house of his own to the family compound. The house courtyard has usually an area shaded with a palm-frond roof supported on poles, under which a raised palm-frond platform is used for sleeping outdoor. This platform is locally called "al'Manamah" (see Khaimat al'Saaf - the palm-frond tent).

2) Guests / men's zone

The guests / men's zone consists of one main confined room called "al'Majlis". It has a rectangular shape, and is used by the family men and their guests for sitting and dinning. It is built on a solid platform raised above the ground level by one step or two. It has one entrance door and is directly accessible through the main indirect entrance.

3) Services zone

The services zone consists of two main spaces, which are:

- a kitchen called "Matbakh"
- a ranch called "Zeribah"

The Matbakh

The "Matbakh" has a rectangular shape. It is located across the courtyard from the family living rooms. It consists of one

confined area used for food preparation, cooking and storing. The family women might cook indoors, but a traditional oven is often kept outdoors of the kitchen. It is locally called "Al'Tannoor". It is used for outdoor cooking when the weather is good.

The Zeribah

The Zeribah consists of one confined shaded area. It is located behind the guests / men's zone and next to the kitchen. It has two doors, one leading to the courtyard, and the other leading to "Al'Seccah". It is used for keeping goats and sheep, where it has in one of its corners a small fodder store.

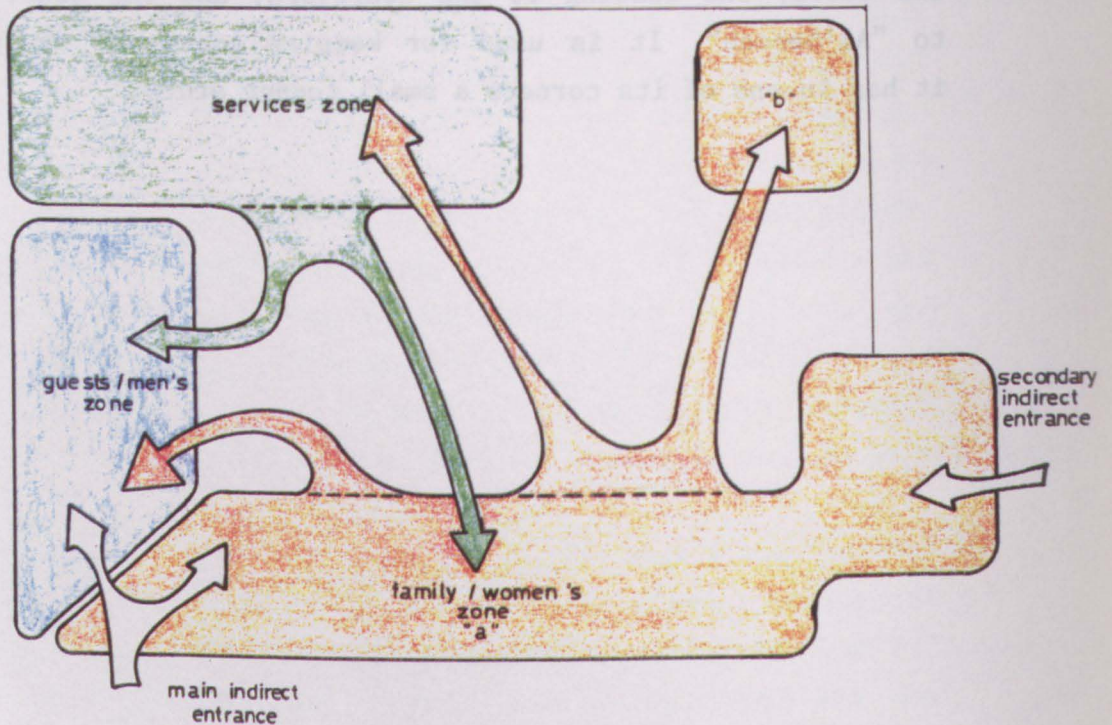

Fig. 84 : A diagram that shows the flow of circulation between the different zones of the house.

Key :



this arrow shows the direction of the main flow of circulation between the different zones of the house.

Functional Aspect

The mud-brick house, "Bait al'Leban", is divided into three main zones (see Fig. 83). Each one of these zones has a certain function. They are as follow:

1) **Family / women's zone**

It contains the family living rooms where each member of the family has his / her own self contained room.

2) **Guests / men's zone**

It contains the male guests reception room, "al'Majlis".

3) **Services zone**

It contains the two basic services which are required to assist life in the house, which are: a kitchen and a small ranch.

These zones are laid out together in order to maintain the rquired functional performance of each one (see Fig. 84). The layout of "Bait al'Leban" shows two separate indirect entrances, a main entrance and a secondary one.

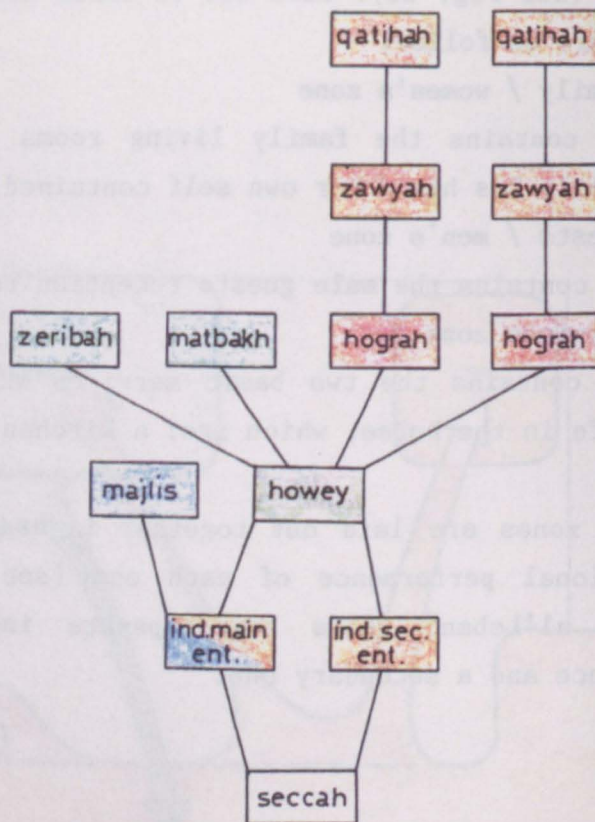
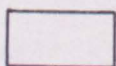

Fig. 85 : A map that shows the hierarchical spatial organisation of "Bait al'Leban".

Note : This map is based on the direct accessibility from one space to the other, and on the method of the justified gamma maps (4).

Key :



a space in the house



one step = a movement from one space to another

In figure 85, "Bait al'Leban" is divided into a number of layers based on the equal number of movements leading to different spaces among it. This number of movements is in relation to the outdoor public space. The more number of movements needed to reach a certain space inside "Bait al'Leban", the deeper this space is. Spaces having a certain depth, therefore lying in the same layer, possess a certain degree of permeability. Beginning from the outdoor public space the penetration of the house spatial pattern is controlled. That is by providing the house with two functional links to the outdoor public space. Each link leads to a series of spaces which have an increasing depth. The increase in depth of each space is governed by the degree of privacy it requires. The increasing depth of the various multi-functional spaces of "Bait al'Leban", resulted in its sequential spatial organisation.

Figure 86(a,b) shows the main spaces of "Bait al'Leban". A graphic interpretation of the division of spaces in accordance with the different activities carried out in them is also shown. The actual areas of spaces are neglected.

The various spaces forming the three zones of "Bait al'Leban" are characterised by being multi-functional spaces. Most of the spaces, if not all, perform a number of different functions at different times of the day. For example: the family living rooms "al'Hogar" (see Fig. 81), where they are used for sitting, sleeping, dining and coffee making.

SPACE TITLE	ACTIVITIES CARRIED OUT IN THE SPACE	GRAPHIC INTERPRETATION
Al'Makhzan	= HOGRAH • ZAWYAH • QATIAH [sleeping , sitting & dinning] [changing room, clothes store] [bathing & ablution]	
Al'Matbakh	= KITCHEN • STORE [food preparation cooking] [food storage]	
Al'Majlis	= GUEST RECEPTION [sitting & dinning]	
Al'Howey	= COURT YARD (protected open area for family gathering and celebrations, circulation, children playground & gardening.)	

Fig. 86 (a) : A table that shows the different activities carried out in the different spaces of "Bait al'Leban", and their graphic interpretation.

SPACE TITLE	ACTIVITIES CARRIED OUT IN THE SPACE	GRAPHIC INTERPRETATION
Al'Zeribah	= ANIMAL SHELTER + FODDER	

Fig. 86 (b)

Conclusion

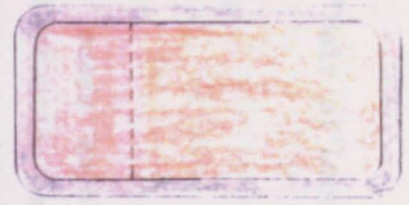
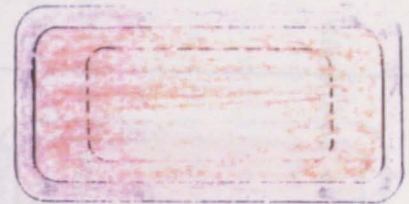
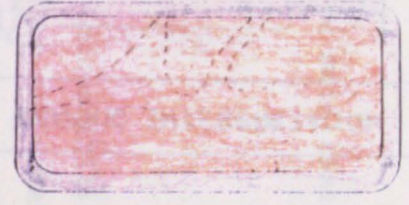
The mud-brick house, "Bait al'Leban", consists of three main zones, which are:

- family / women's zone
- guests / men's zone
- services zone

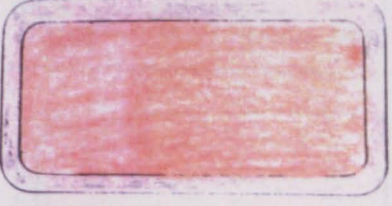
The layout of these zones maintains the required accessibility between them without obstructing one circulation flow from the other. Bait al'Leban has a hierarchical organisation of spaces, which perform a variety of functions at different times of the day.

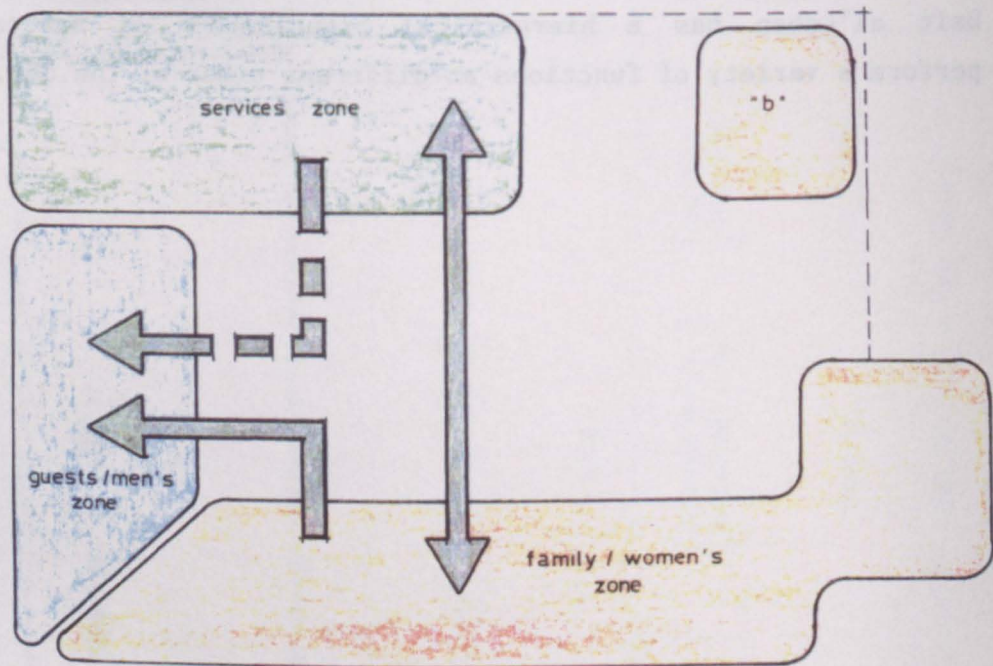

Fig. 87 : A diagram that shows communication degrees between the house different zones.

Key :

- ↔ mutual and dense
- single and frequent
- - - → single and infrequent

Socio-cultural Aspect

The design of "Bait al'Leban" is a direct interpretation of the social behaviour patterns of its households., where the social value of privacy is of great importance. Communication between different zones of "Bait al'Leban" is governed by the degree of privacy each zone requires (see Fig. 87). Supplying the needed protection, from immediate visual & aural inspection, for each zone achieved privacy for each of their multi-functional spaces (see Fig. 88).

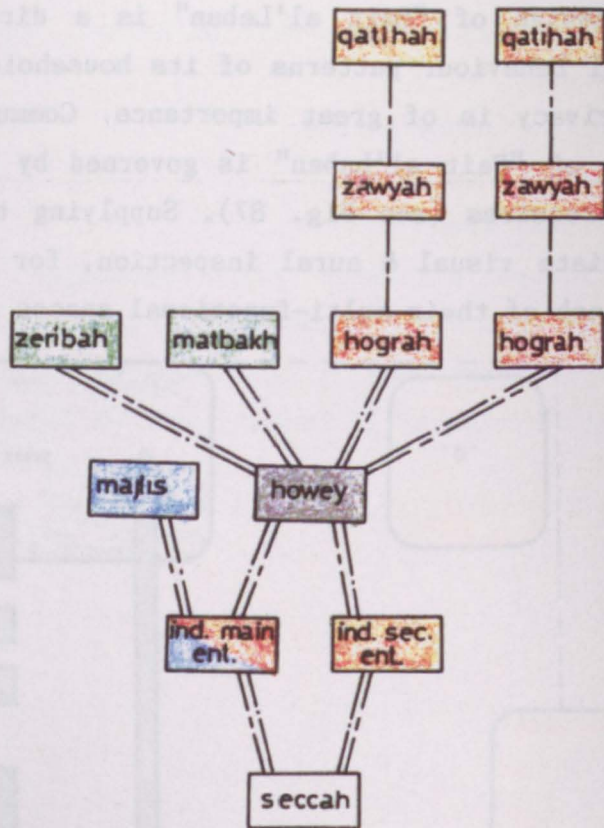

Fig. 88 : A map that shows the types of communication between different spaces of "Bait al'Leban".

Note : This map is based on the immediate audio/visual inspection from any space on the next permeable one (5).

Fig. 89 : A diagram that shows communication degrees between the various different zones

- Key :
- a space in the house
 - direct aural
 - indirect aural
 - direct visual
 - indirect visual

A courtyard house

The components of "Bait al'Leban" overlooking a courtyard, allowed the family to have a private outdoor space within the house area. While the family living rooms have doors only overlooking the courtyard, ventilation openings are located at the top of the walls overlooking the outside. Thus preventing immediate visual inspection on the rooms from the outside.

Separation of zones

Separation between the three zones of the house was essential in order to maintain privacy. This was achieved by placing the main indirect entrance between the family / women's zone and the guests / men's zone. The services zone placed across the courtyard from the family / women's zone, allowed easy access to the family members without passing through the guests / men's zone.

Separate indirect entrances

Supplying the house with two indirect entrances, secures the privacy of the family members. Both entrances, being indirect, protect the courtyard from outside visual inspection.

The boundary wall

The boundary wall "al'Hotah", having sufficient height, prevents direct visual inspection from outside the house. Thus protecting the privacy of the households outdoor space, and defining their territory.

Conclusion

The mud-brick house, "Bait al'Leban", provides the households with the privacy needed to carry out their every day life. The location of each space in "Bait al'Leban" is a direct result to the degree of privacy it requires.

Technical Aspect

The process of building "Bait al'Leban" as carried out utilising natural building materials. A study of these building materials and the applied method of building "Bait al'Leban" will be carried out.

The utilised materials

The main utilised natural building materials in building "Bait al'Leban" are:

- 1) Al'Leban
- 2) Stones
- 3) Wood
- 4) Al'Toor
- 5) Leaf al'Nakhl
- 6) Al'Salhah

1) Al'Leban

Al'Leban is the local name given to a slushy paste made by mixing mud, chopped straw and water. It is used in making mud-bricks. It is also used as a binding mortar, plaster and roof finishing material.

2) Stones

Stones are collected at the feet of the nearby mountain of "Jebel Hafit" (see Chapter One, Fig. 7). Stones are used in building the wall footings.

3) Wood

Wood is the dead palm-tree trunks. They are used as beams and poles in building the framework of the palm-frond roofs, and in roofing the house rooms (see Ecological Cond.).

4) Al'Toor

Al'Toor is the local name given to the palm-tree fronds. Mats

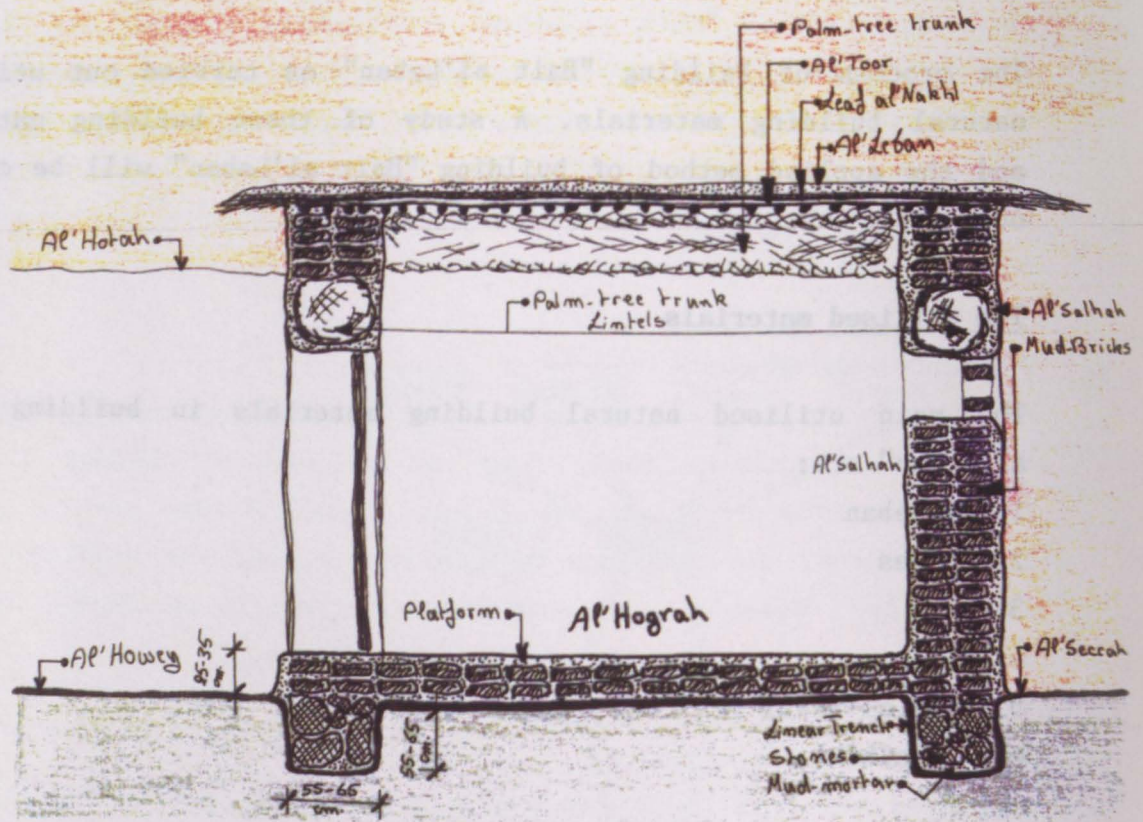

Fig. 89 : A sketch that shows a transversal section passing through "Bait al'Leban".

of interweaved palm-fronds forms one of the roof layers.

5) Leaf al'Nakhl

Leaf al'Nakhl is the local name given to the fibrous bark that grows at the bottom of the palm-tree. It is used as a thermal insulating material within the roof layers.

6) Al'Salhah

Al'Salhah is the local name of the wall plaster. The plaster applied on both sides of the walls of "Bait al'Leban" is of the same constituents of "al'Leban".

The applied method in building "Bait al'Leban"

The applied method in building "Bait al'Leban" can be described through out the following steps :

1) Making the mud-bricks

The mud-bricks are made by mixing mud and chopped straw. The mixture is then wetted to a slushy paste with water and thoroughly trampled on to give a smooth mix. Then it is left for a few days to mature. When the mud mix is ready it is packed down into a wooden frame of square shape. It is 25 x 25 cm. and 10 cm. deep. This frame is open from the top and the bottom, so the mud-brick which it forms can easily be tapped out. Rows of mud-bricks are then left to dry in the sun, before being stacked on their edges ready for use.

2) Walls footings

Walls footings are built by digging linear trenches in the ground. These trenches are 1.5 - 2 ft. deep and 1.5 - 2 ft; deep. Determining the location of the walls, these trenches are filled with stones bound together with mud-mortar (see Fig. 89).

3) The platform

The rooms areas, defined by the linear walls footings, are then covered with two or three horizontal layers of mud-bricks bound together with mud-mortar. The platform thickness reaches then between 25 - 35 cm.

4) The walls

The walls are constructed on top of the linear footings surrounding the floor platform. They are built of horizontal layers of mudbricks bound together with mud-mortar. The walls thicknesses vary from 55 - 60 cm.

5) The lintels

The doors lintels are made of dead palm-tree trunks. They are laid on top of the doors openings with suitable overlapping on both sides. Then walls construction continues until it reaches the desired height of the roof.

6) The roof

The construction of the roof is carried out by laying palm-tree trunks on top of the walls. They are laid parallel to the short side of the rooms at about 60 cm. intervals. The palm-frond mats, "al'Toor", are then laid on top perpendicular to the direction of the trunks. A layer of fibrous bark, "Leaf al'Nakhl", then covers the roof mats. The mud-mortar, "al'Leban", is poured on top of the preceding layer forming the final roof layer.

Conclusion

The mud-brick house, "Bait al'Leban", is built entirely with natural building materials. These materials are found in the local environment and surroundings. Bait al'Leban building materials have the advantages of being quick and simple to prepare.

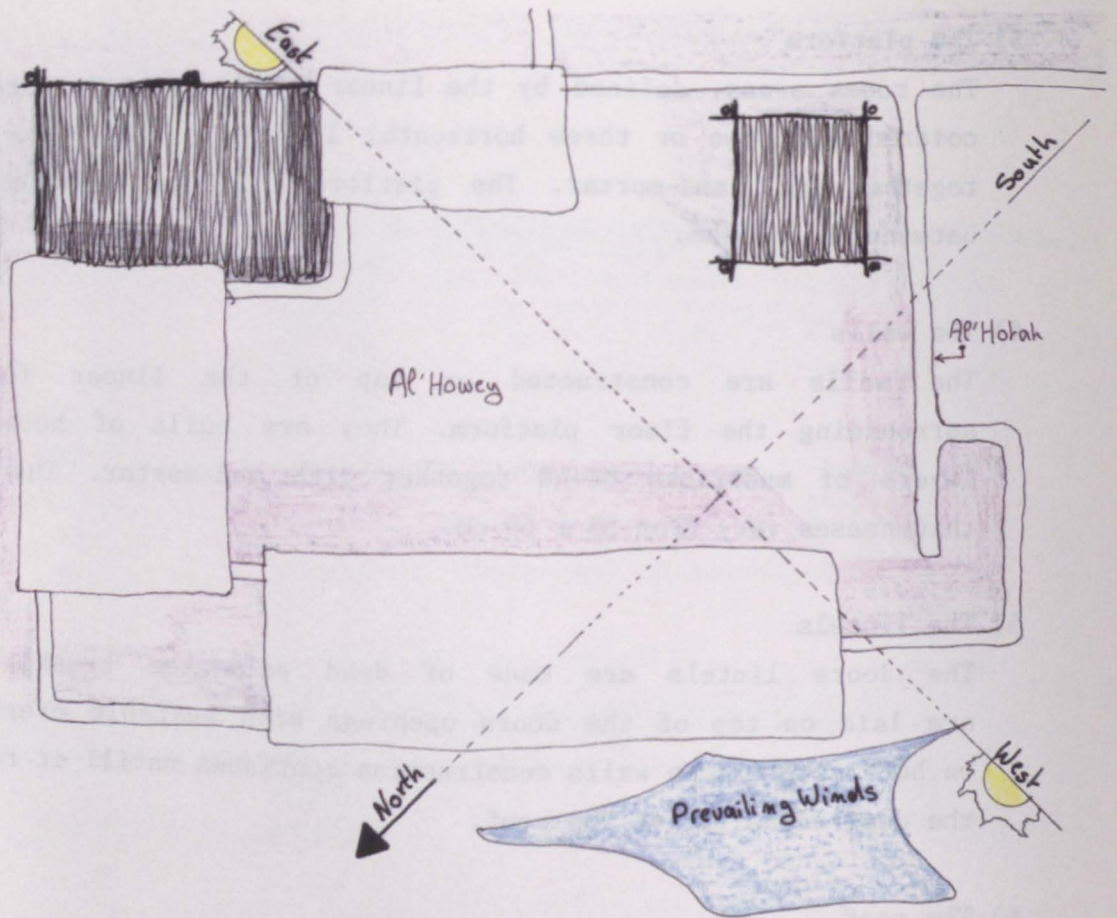

Fig. 90 : A sketch that shows the orientation of the mud-brick house.

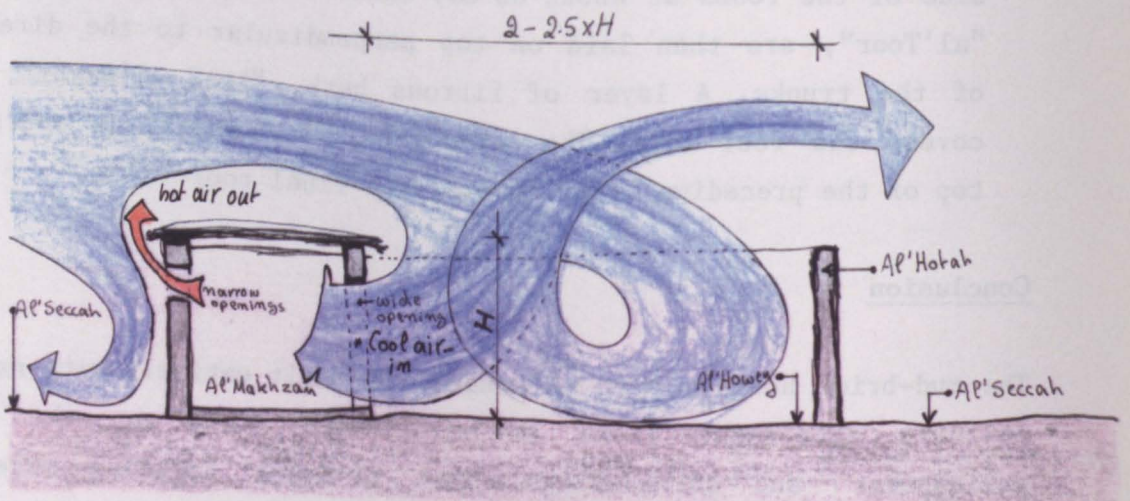

Fig. 91 : A sketch that shows the natural ventilation of the mud-brick house

Environmental Aspect

In spite of the severe environmental conditions of Abu Dhabi's main land, the mud-brick house adapts efficiently to the local environmental conditions. In the process of designing and building "Bait al'Leban", the local people took into consideration the following:

- 1) The shape and the orientation of the house.
- 2) The natural ventilation.
- 3) The sun and sand protection.

1) The shape and the orientation of the house

The shape

The mud-brick house, "Bait al'Leban", has rectangular shape (see Fig. 81). The roofs of the house are flat, thus reducing their exposed surface area to the sun.

The orientation

The mud-brick house, "Bait al'Leban", always faces east to south-east (see Fig. 90). This particular orientation provides a considerable shaded area in front of the house. It allows the households to benefit from the morning sun, and avoid the afternoon sun.

2) The natural ventilation

Natural ventilation of the mud-brick house is maintained through its orientation, opening sizes and location, and being built around a semi-square courtyard (see Fig. 91). The window openings are narrow and located high on the backside walls. The wide openings, doors, are located on the opposite sides across the rooms. Over looking the courtyard, they allow the cool air to enter the rooms. The windows being narrow and high allow the hot air inside the rooms to evacuate. Thus reducing its temperature and maintaining continuous natural ventilation.

3) The sun and sand protection

The openings being narrow and located on the northern walls of the house provide indirect natural light. There are neither windows nor similar narrow openings in the eastern and western walls. The narrow ventilation openings are blocked with peaces of wood to protect the interior of the house from the seasonal dusty winds. The mud-bricks being a bad heat conductor and the walls being considerably thick about 2 ft., helps reducing and delaying the heat transfer from outside to inside the house.

Conclusion

The previous study shows that the house of "Bait al'Leban" and its constituents are generally of rectangular shapes. Built around a courtyard, they benefit from the diurnal temperatures, increase the shaded outdoor areas and increase the number of the shaded external building surfaces. Natural ventilation is secured, where openings in eastern and western walls are completely avoided. The use of heavy building materials in relatively thick walls and roofs, reduces the transmited heat to inside the house.

2.2 Analysis of the (social, environmental, etc.) feasibility of the houses built after the discovery of oil

In fulfilment of the ambitious housing policy, developed by the government of Abu Dhabi, of serving the provision of local people with houses. A number of foreign architects were involved in the development of the low income house types. A detailed analytical study of two types of these houses will be carried out. These two types are:

2.2.1 Type 1

Type 1 is one of the low income house types built on Abu Dhabi's main land. It was built in numbers forming a large neighbourhood of 1200 houses. This neighbourhood is called "Al'Merkhanyah", and it is located in Al'Ain city (see Site Cond., Fig 8).

2.2.2 Type 2

Type 2 is one of the low income house types built on Abu Dhabi's coastal areas. It was built to form a small group that consists of 10 houses. It is located in a village called "Bida al'Mutawwa" to the west of Abu Dhabi island (see Site Cond., Fig 8).

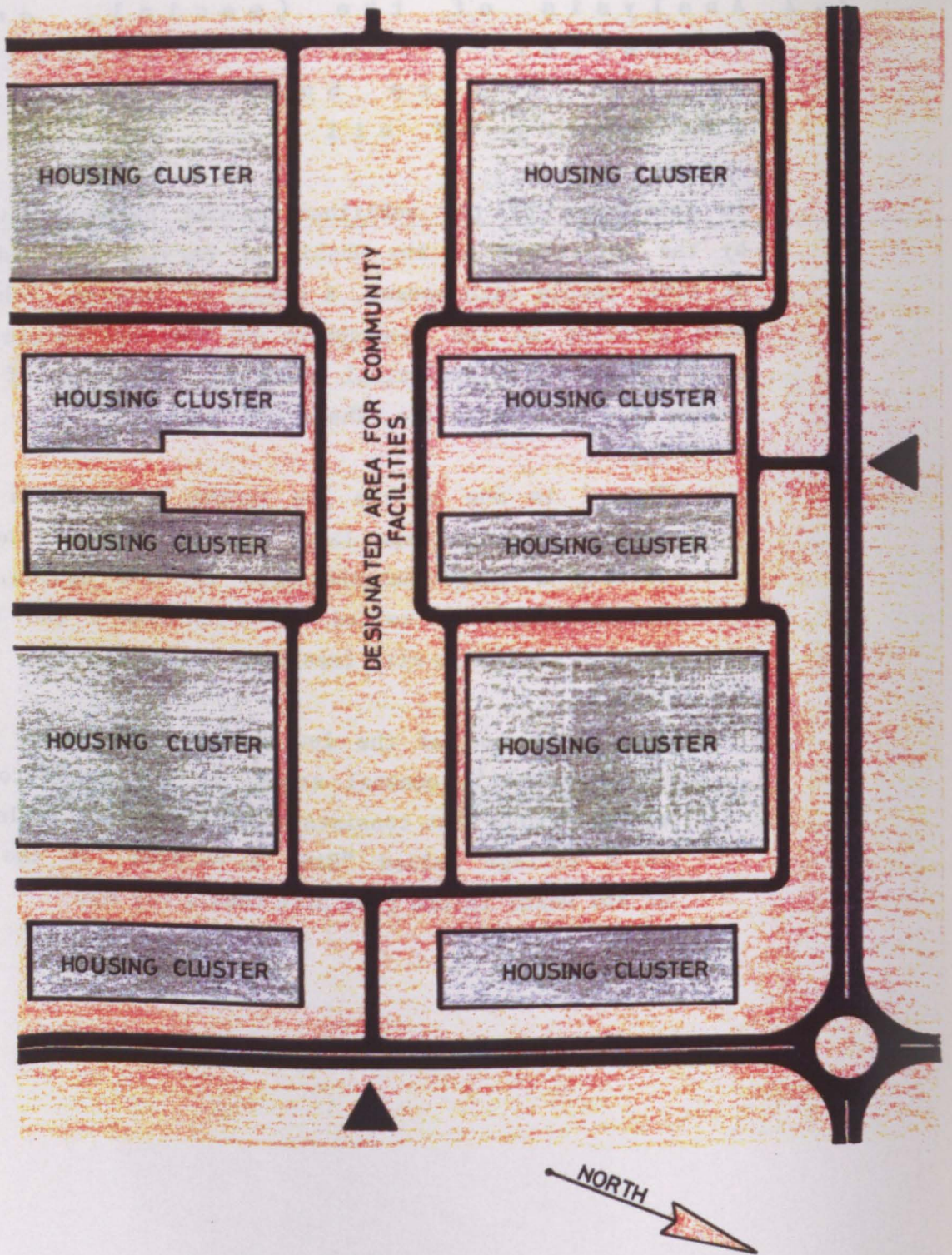

Fig. 92 : A sketch that shows how type 1 of these low-income houses are laid out together (23).

2.2.1 Type 1

These low income houses are built attached to each other forming groups of four houses. These groups of houses are laid out next to each other forming housing clusters (see Fig. 92). Each house is granted to a different family. This type of house is small, it consists of one bedroom only. The groups of houses are either of rectangular or square regular forms. This regularity of forms generates a rectilinear pattern of streets visually permeable to strangers. The tendency towards creating housing clusters laid out together within an iron-grid pattern of roads, resulted in a number of intersecting pedestrian passage ways parallel to the surrounding streets. Such as the example of the city of Riyadh, which is based on the concept of the city for the car. The concept which does not conform with traditional cities.

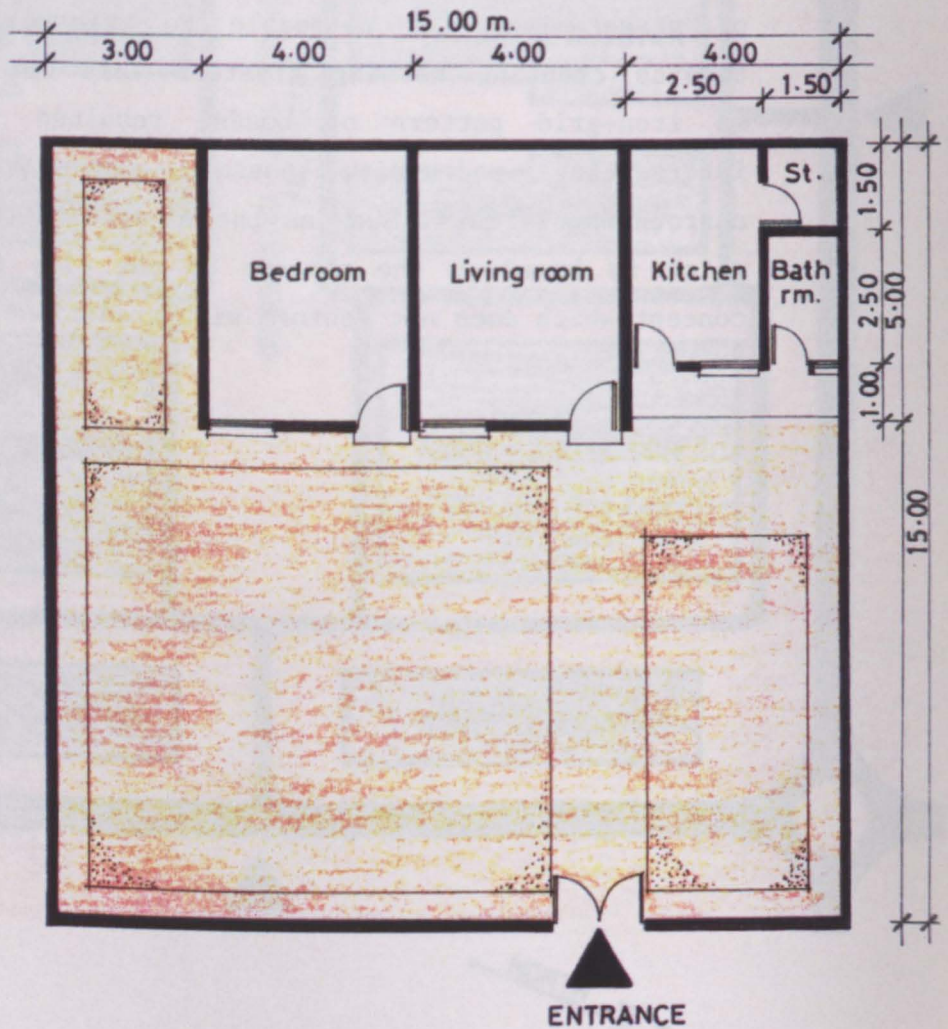
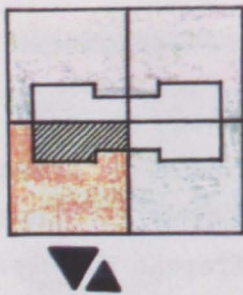

Fig. 93 : An example for the low-income house type 1 (23).

Note : This drawing is not to scale; dimensions shown are approximated. Double orientation is disadvantageous where if two houses have the best orientation, the other two will have the worst orientation.

An example for the low income houses type 1 is shown in figure 93. This type of house is divided into two main zones (see Fig. 94), which are :

- 1) Family zone
- 2) Services zone

These two zones are built attached to each other. They are located in one of the corners of a square shaped piece of land. A boundary wall surrounds the land to meet the two side walls of the built-up area. The house has a single direct entrance located on the facing side of the boundary wall. Being the only access to the house, it is used by both family members and guests.

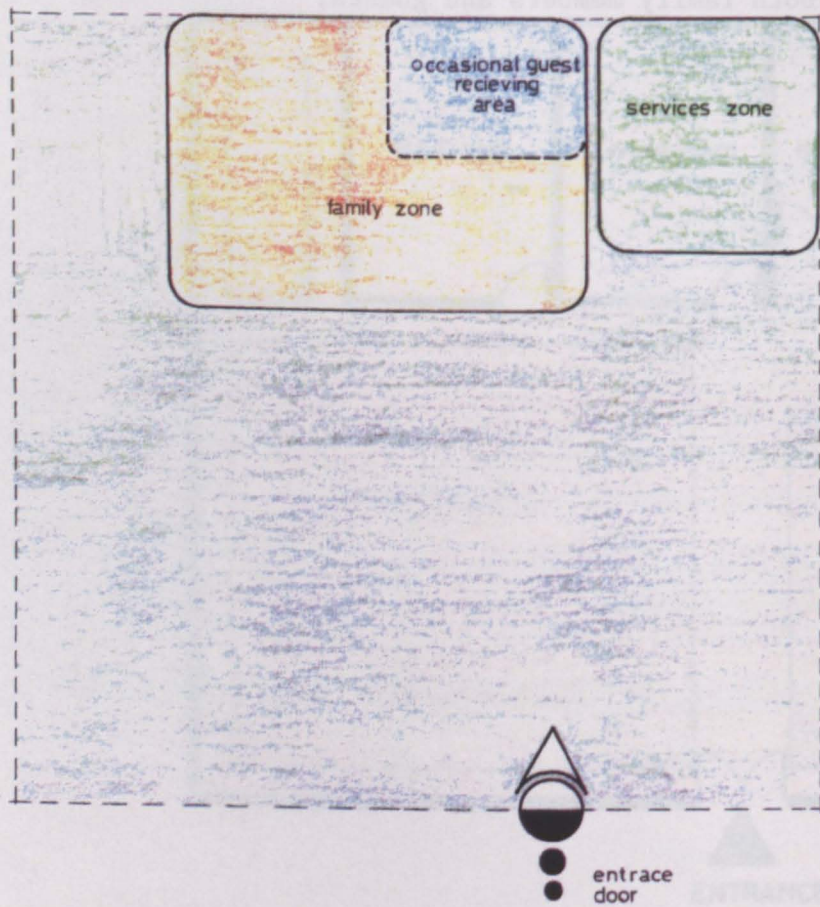

Fig. 94 : A diagram that shows the different zones of the low-income house type 1.

Each zone in the house consists of one or a number of functional spaces, which are as follow :

1) Family zone

The family zone consists of one bedroom and one living room. They have rectangular shapes, with their width facing the outdoor area. The bedroom consists of one confined area for sleeping. The living room consists of one confined area for both sitting and dinning. The living room is occasionally used for receiving guests. The family zone is built on a solid platform raised one step above the ground level.

2) Services zone

The services zone consists of a kitchen and a bathroom. It is located between the family zone and the boundary wall. The kitchen consists of two confined areas: an area used for food preparation and cooking, and a storage area. The bathroom is located between the kitchen and the boundary wall. It is used for bathing, ablution and it contains the w.c.

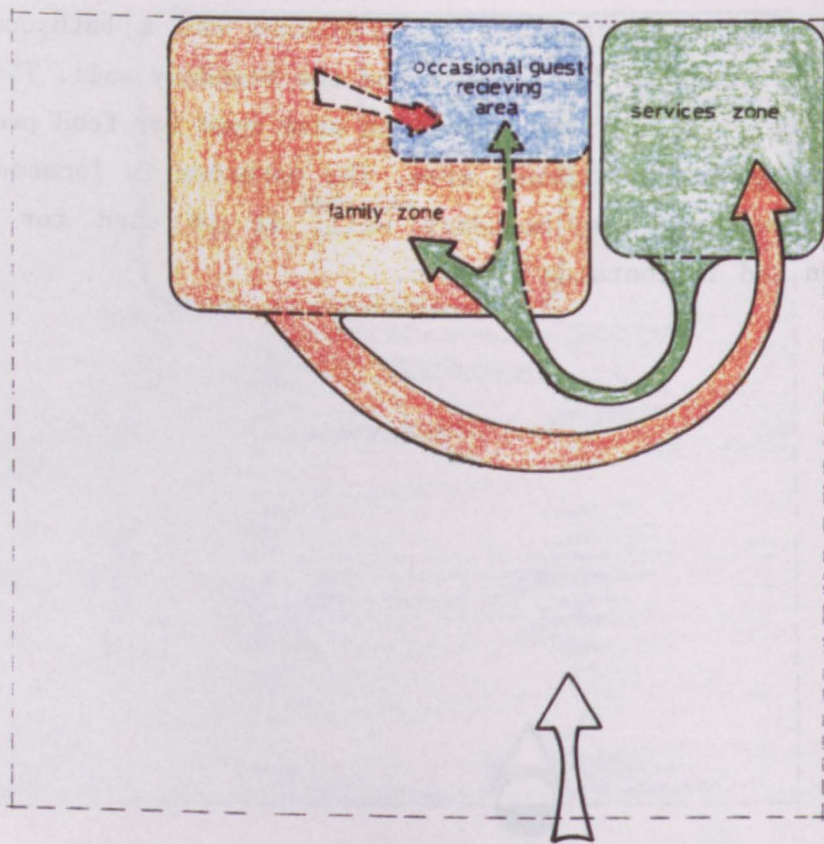

Fig. 95 : A diagram that shows the flow of circulation between the different zones of the house.

Key :



this arrow shows the direction of the main flow of circulation between the different zones of the house.

Functional Aspect

This type of house is divided into two main zones (see Fig. 94). Each one of these zones has a certain function, which are:

1) Family zone

It contains the family bedroom and living room. All the family members have only one bedroom and one living room.

2) Services zone

It contains the kitchen and the bathroom. All the family members have to use the same bathroom.

Figure 95 shows the main flow of circulation between the different zones of the house.

This type of house is divided into two main zones (see Fig. 95). Each one of these zones has a certain function, which are:

- 1) Family zone
- 2) Services zone

It contains the family bedroom and living room. All the family members have only one bedroom and one living room.

It contains the kitchen and the bathroom. All the family members have to use the same bathroom.

Figure 95 shows the main flow of circulation between the different zones of the house.

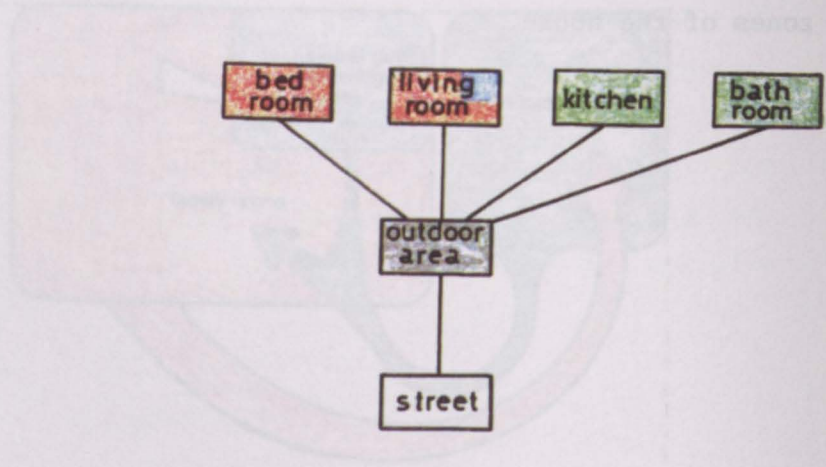

Fig. 96 : A map that shows the hierarchical spatial organisation of the low-income house type 1.

Note : This map is based on the direct accessibility from one space to the other, and on the method of the justified gamma maps (4).

Key :

□ a space in the house

— one step = a movement from one space to another

In figure 96 the house is divided into a number of layers based on the equal number of movements leading to different spaces among it. This number of movements is related to the out door public space, in this case the street. The more number of movements needed to reach a certain space inside the house, the deeper the space is. Spaces having a certain depth, therefore lying in the same layer, posses a certain degree of permeability. Begining from the out door public space, the house is provided with one functional link. Being a direct entrance, it does not help controlling the penetration of the house spatial pattern. This link leads to a certain number of spaces having the same depth. Disregarding their different functions and the different degrees of privacy they require, they are laid out in the same layer of the house. The result is a very shallow layout.



SPACE TITLE	ACTIVITIES CARRIED OUT IN THE SPACE	GRAPHIC INTERPRETATION
Bed room	= SLEEPING	
Living room	= SITTING + DINNING + OCCASIONAL GUEST RECEPTION	
Kitchen	= COOKING + FOOD PREPARATION + STORAGE	
Bathroom	= BATHING + ABLUTION + W.C.	

Fig. 97 : A table that shows the different activities carried out in the different spaces of the low-income house type 1, and their graphic interpretation.

Figure 97 shows the main spaces of the house. A graphic interpretation of these spaces, in accordance with the activities carried out in them, is also shown. The actual areas of spaces are neglected. Some of the spaces forming the house are characterised by being single functional spaces, such as the bedroom. Some others are multi-functional spaces, such as living room and the kitchen.

Conclusion

The house consists of two main zones which are:

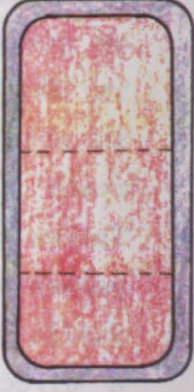
- 1) Family zone
- 2) Services zone

There is not a defined guest / men's zone and a family / women's zone in the house. Both are mixed in common family zone. This disturbs the family flow of circulation within the zone when receiving male guests in the house. The layout of the two zones, the services zone & the family zone, maintains the required accessibility between them. The layout of the house spaces in general resulted in a very shallow, easy to penetrate spatial organisation. Disregarding the degree of privacy that each space requires, resulted in mixing spaces that require different permeability degrees in the same layers.

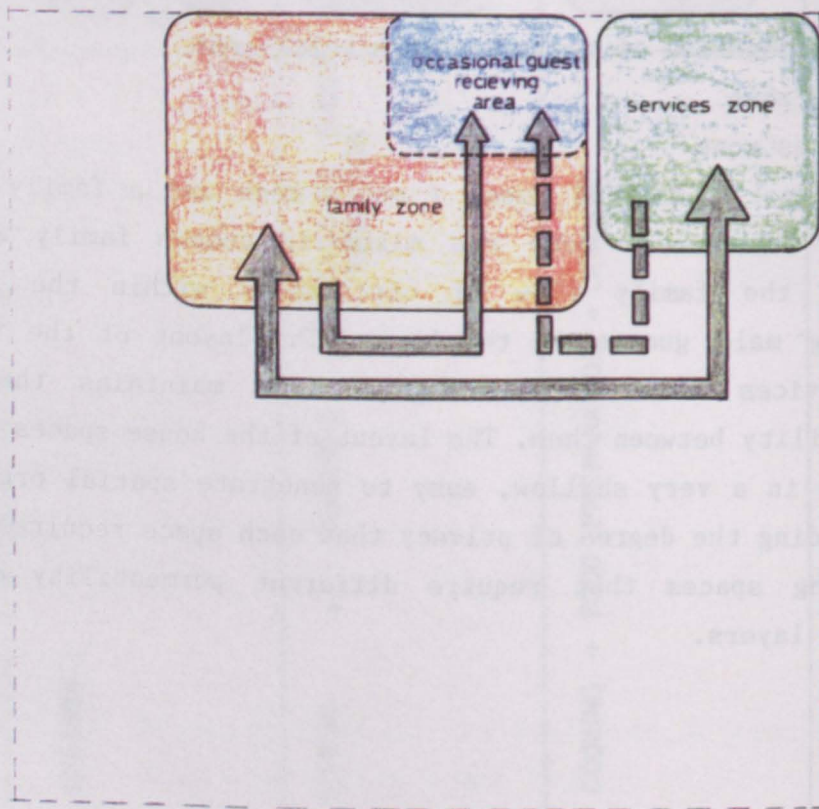

Fig. 98 : A diagram that shows communication degrees between the house different zones.

Key :

- ↔ mutual and dense
- single and frequent
- - - → single and infrequent

Socio-cultural Aspect

The design of this house type does not correspond to the social behaviour patterns of the households, where the social value of privacy has been ignored. Communication between different zones of the house is not governed by the degree of privacy each zone requires (see Fig. 98).

The lack of protection from the immediate audio/visual inspection from the outside on the house (see Fig 99). Once the main entrance door is open, one can see clearly all the doors of the house rooms. The exclusion of the guests / men's zone from the house layout and its separate entrance, resulted in the disturbance of the family women's privacy. It restrains their circulation when the family males are receiving their guests. The boundary wall and the main entrance having insufficient heights, allow direct visual inspection from the outside on very private areas such as the bathroom. Thus highly affecting the privacy of the households outdoor space, and even their bathroom.

The grouping of each four houses of this type together created four common, single dividing walls. These walls separate the four houses. The walls being thin, and inevitably are not noise insulators, allow direct aural inspection from one house on the other. Over hearing between neighbours highly affect their privacies.

Conclusion

This type of low income houses does not provide the households with the privacy they need to carry out their every day life. The negligence of the various family sizes, which varies from 1-3 persons to 10 or more (see Socio-cultural background of the local people). Only families of the size group "A" can occupy such house type, noting that they form only 8% of the total population. The future expansion of the built houses has not been taken into consideration. This makes it impossible for the 92 % left of other family sizes to occupy this type of houses.

The design of this house type does not correspond to the social behaviour patterns of the households, where the social values of privacy has been ignored. Communication between different rooms of the house is not governed by the degree of privacy each room requires (see Fig. 98).

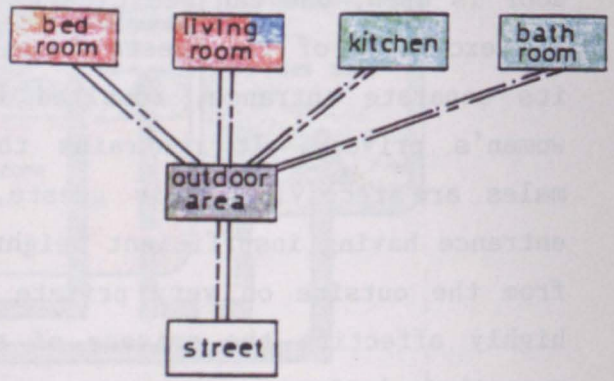

Fig. 99 : A map that shows the types of communication between different spaces in the house.

Note : This map is based on the immediate audio/visual inspection from any space on the next permeable one (5).

- Key :
- a space in the house
 - direct aural
 - indirect aural
 - direct visual
 - indirect visual

Technical Aspect

The process of building this type of low income house was carried out utilising contemporary building materials, and applied construction methods. It is constructed with prefabricated reinforced concrete walls and slabs. The house is raised one step above ground level. The family zone is internally finished with cement/sand wall plaster and paint, and terrazzo floor tiles. The services zone is internally finished with glazed wall tiles, and non-slip ceramic floor tiles. Ceilings are finished with cement/sand plaster and paint. The house is externally finished with cement/sand plaster and paint, where the paint colour is left to the architect's choice. The roof is finished with precast concrete tiles laid on a cement/sand screed. Water proofing membrains are laid but there is not any kind of thermal insulation, neither to the roof nor to the walls. Windows are single glazed, and doors are wooden flush doors.

Conclusion

The house construction method and materials does not include neither thermal insulating materials nor methods. The applied method in constructing this type of house is quick.

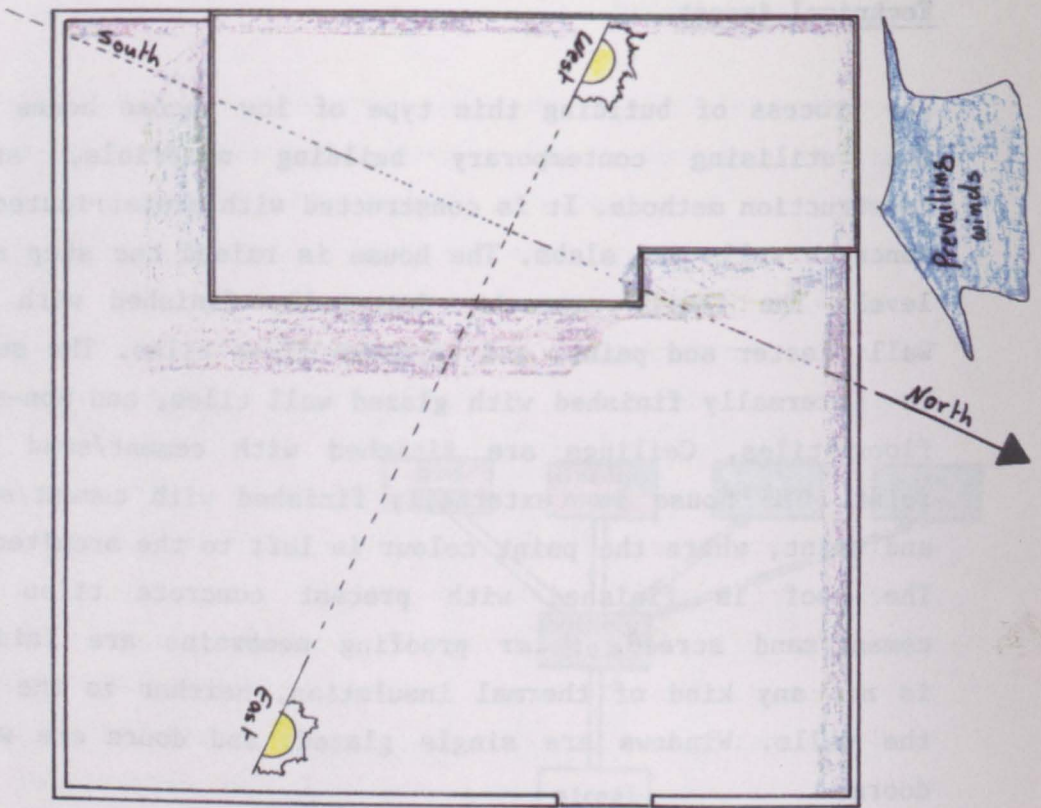

Fig. 100 : A sketch that shows the east to north-eastern orientation of the house.

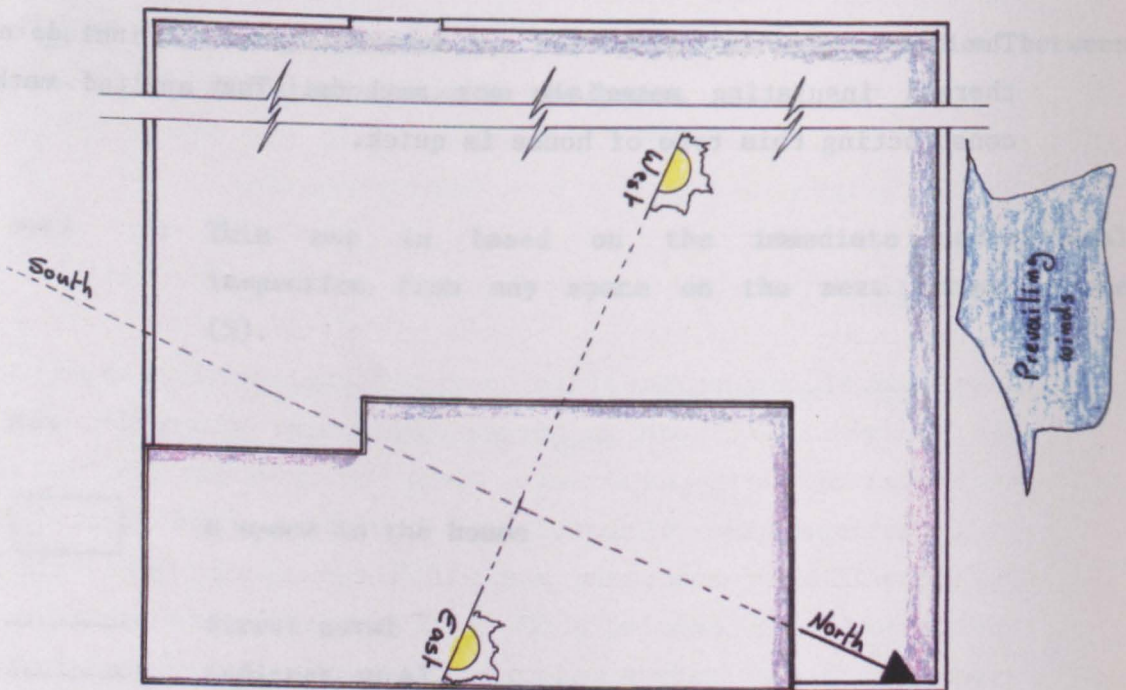

Fig. 101 : A sketch that shows the west to south-western orientation of the house.

Environmental Aspect

Regarding the severe environmental conditions of Abu Dhabi's main land, this type of low income house does not adapt efficiently to the local environment. This is due to the negligence of the following :

- 1) The orientation of the house
- 2) The natural ventilation
- 3) The sun protection

1) The orientation

The house layout being designed with the aim to assemble it with three others of the same layout in groups of four houses resulted in the following : two of the four houses only will have better orientation, in this case, east to north-eastern (see Fig. 100). The other two will have a worst orientation, in this case, west to south-western (see Fig. 101). Either orientation exposes the house largest external surface area to the sun all the day through. Therefore increasing the the amount of heat gain inside the house rooms, which is not recommended at all. The first orientation will provide outdoor shaded areas in the afternoon; when needed. The second orientation will provide outdoor shaded areas in the morning; when not needed.

2) The natural ventilation

In the case of either orientation, natural ventilation is not maintained. This is due to the positioning and the sizes of the ventilation openings (windows or doors) in the walls parallel to the main direction of the prevailing winds. Sometimes they are even positioned in the walls facing completely the opposite direction. Windows should have been narrow and located high on the walls in order to evacuate the hot air inside the rooms. Most of all is the absence of the enclosed courtyard, which provides shaded areas and collect the cool air on summer nights.

3) The sun protection

The precast reinforced concrete walls, being relatively thin and not thermally isolated, helps transferring heat to the air mass inside the rooms. Remark that windows are wide and very shallow, they are located either on eastern or western walls of the house. Both windows orientations are highly uncommendable in hot and dry weather (see Climatological Cond. for local types of climate). The unemployment of neither sunscreens nor sunbreakers, aggravates the effect of the direct sun rays on the interior of the house.

Conclusion

This low income house type does not provide comfortable living conditions. Natural ventilation, enclosed courtyards, sun protection and proper orientation are totally ignored. Therefore the house does not adapt to the local climatological conditions of its surrounding environment.

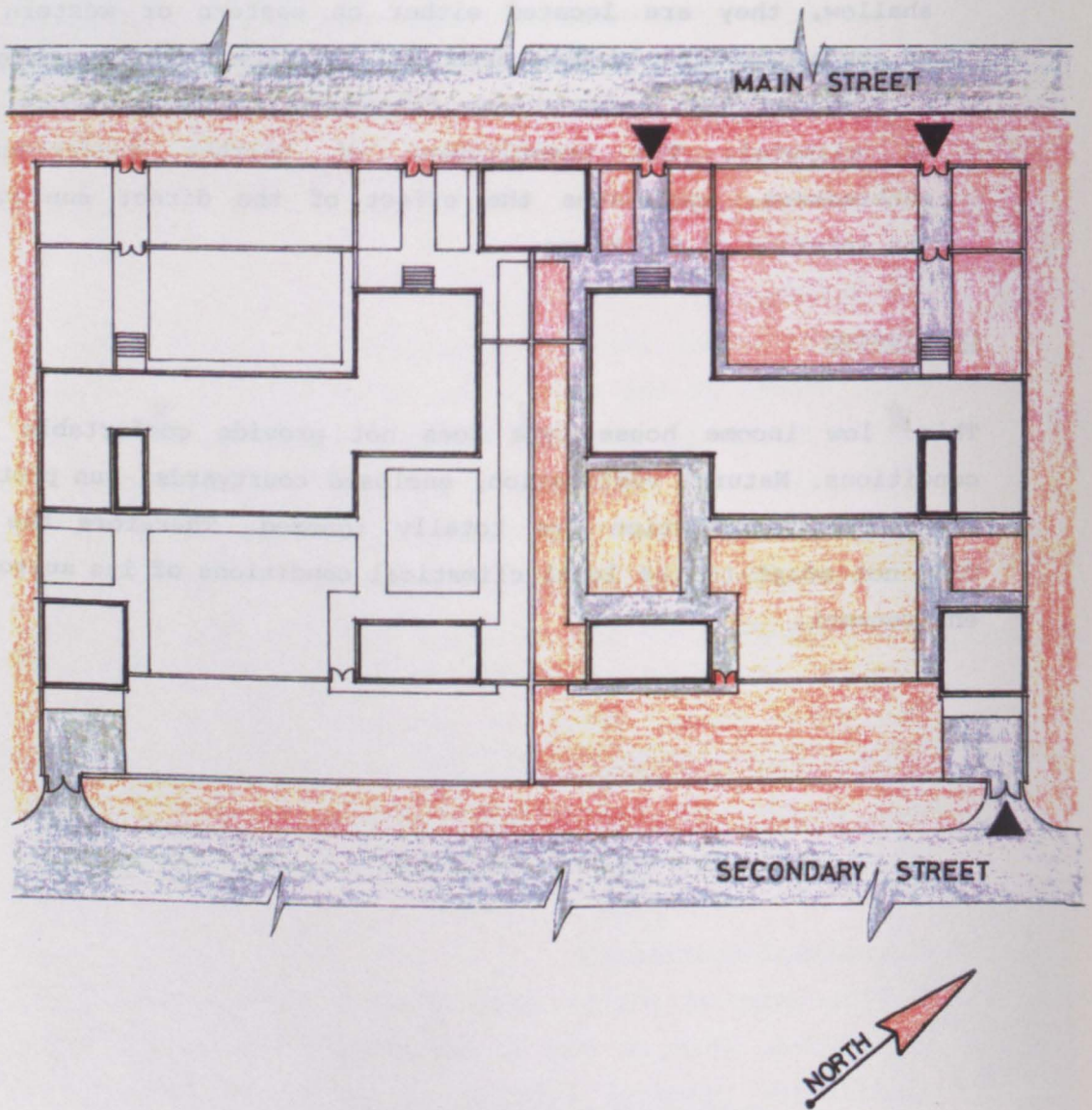

Fig. 102 : A sketch that shows how type 2 of these low-income houses are laid out together (24).

2.2.2 Type 2

These low income houses are built attached to each other forming a group of twin houses. These twin houses are laid out adjacent to each other forming a row of ten houses, in total, facing north. They are built on plots of land of rectangular forms (see Fig. 102). Each block of twin houses is surrounded by streets. Each of these houses is granted to a different family. This type of house is relatively large compared to other types of low income houses in Abu Dhabi.

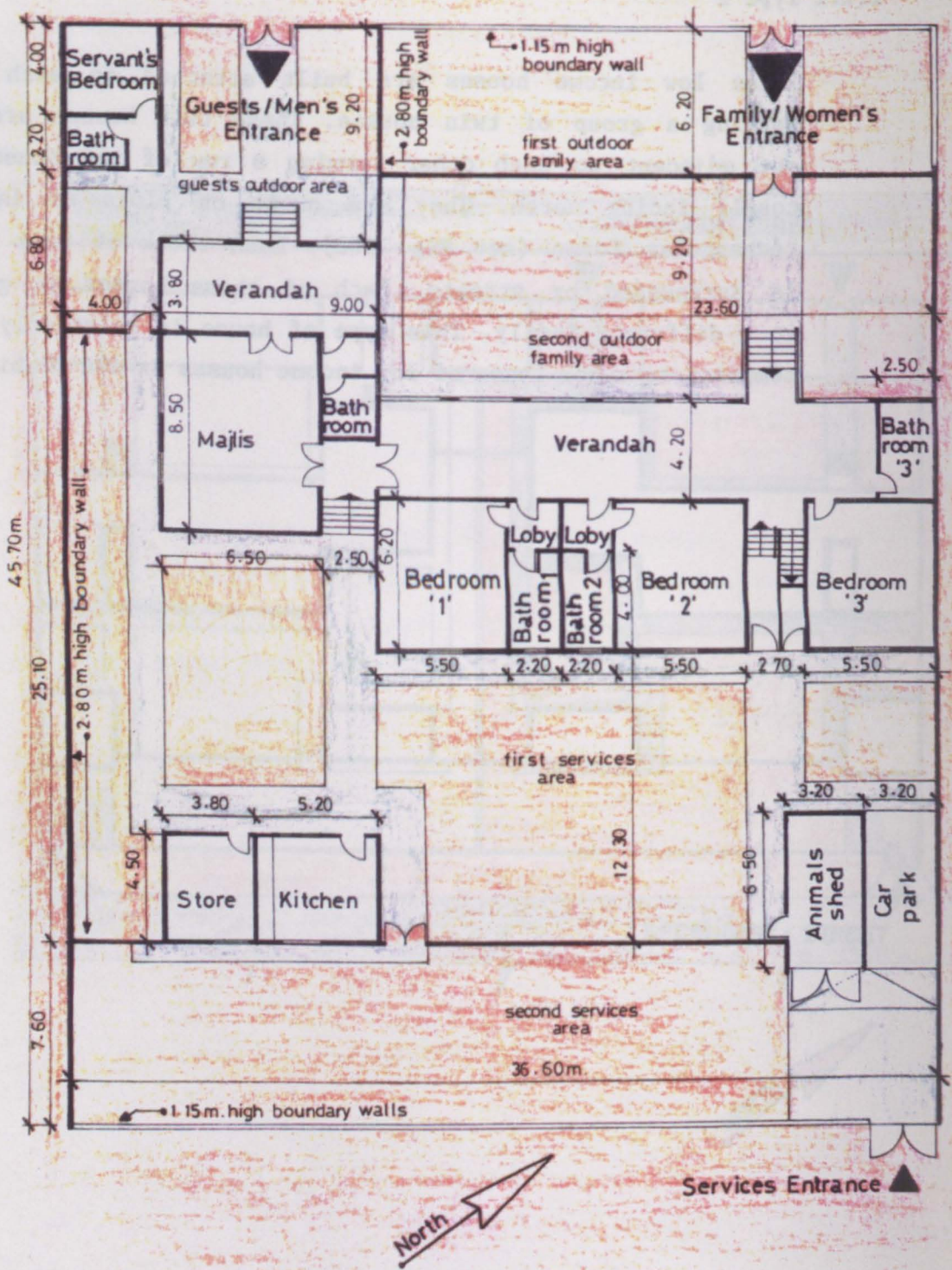

Fig. 103 : A sketch that shows the low-income house type 2 (24).

Note : This drawing is not to scale; dimensions shown are approximated.

An example for the low income house type 2 is shown in figure 103. This type of house is divided into three main zones (see Fig. 104), which are :

- 1) Family / women's zone
- 2) Guests / men's zone
- 3) Services zone

The first two zones are built attached to each other. The third zone, being fragmented into three parts, is completely detached from the two previous zones. A boundary wall links the fragments together. While eastern and western boundary walls are of single walls, the northern and southern boundary walls are of double walls. The double boundary walls being parallel to each other, they are separated by open areas of about seven metres wide. The house entrances are located on the northern and the southern boundary walls only. The exterior boundary wall bears three main entrances, while the interior boundary wall bears four secondary entrances.

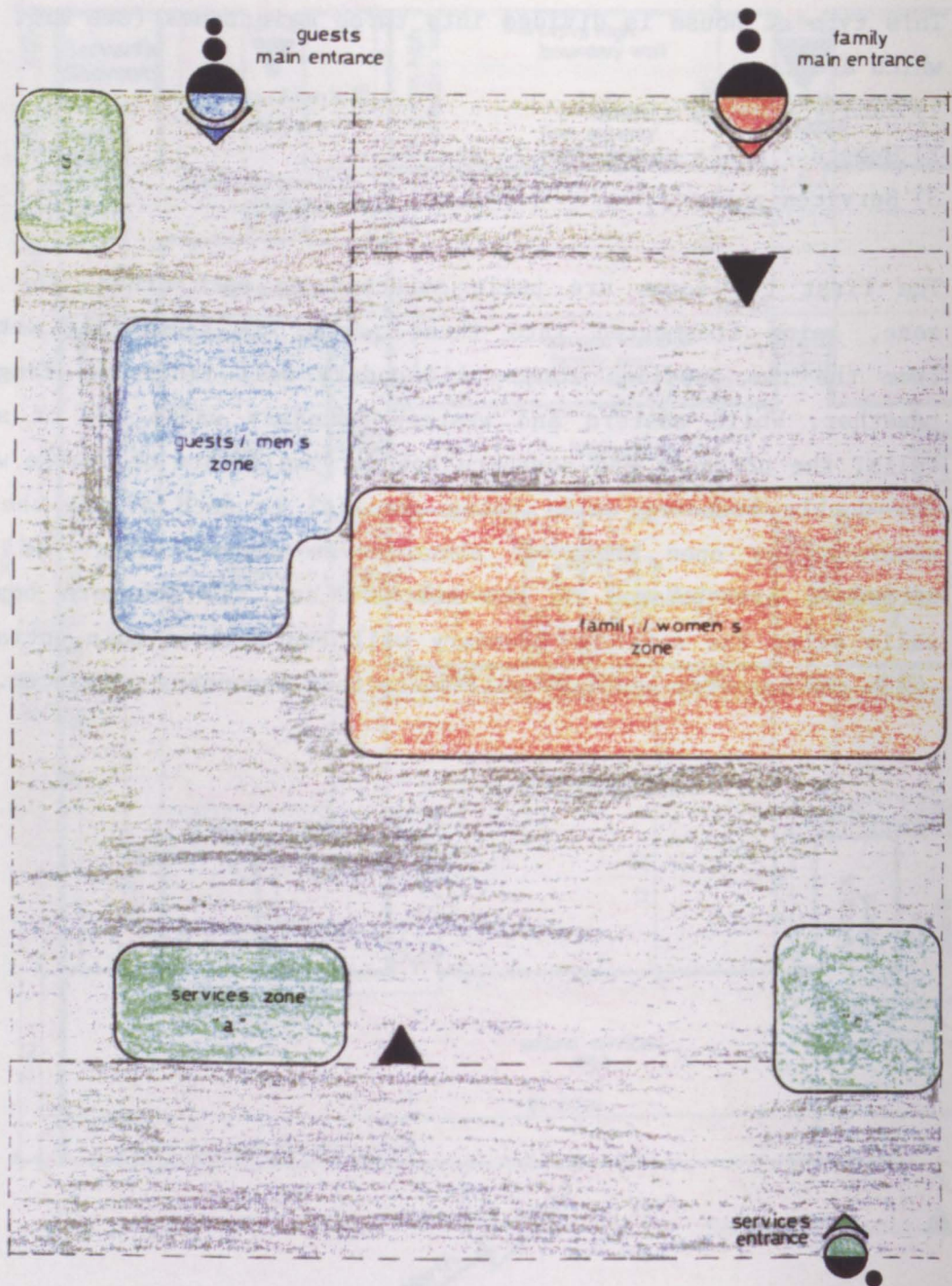

Fig. 104 : A diagram that shows the different zones of the low-income house type 2.

Each zone in the house consists of one or a number of functional spaces, which are:

1) Family / women's zone

The family / women's zone consists of three family bedrooms and three bathrooms. They are generally of rectangular shapes with their widths facing the family / women's entrance. Each bedroom consists of one confined area used for sleeping, where bathrooms are used for bathing, ablution and w.c. They are raised above the ground level by seven steps. They are directly accessible from the family outdoor area through a semi-enclosed linear verandah, which is raised to the same level. The family / women's zone is provided with a stair case that leads to the roof level.

2) Guests / men's zone

The guests / men's zone consists of a confined area used for sitting and dinning called "al'Majlis", and a bathroom. Al'Majlis is of a rectangular shape with its width facing the guests / men's entrance. Both "al'Majlis" and the bathroom are raised above the ground level by seven steps. They are directly accessible from the guests outdoor area through a semi-enclosed linear verandah, which is raised to the same level.

3) Services zone

The services zone is raised above the ground level by two steps. It consist of five main spaces (see Fig. 103), which are:

- a kitchen
- a store
- a servant's room
- an animals shed
- a car park

The kitchen

The kitchen is of slightly recatngular shape. It is raised above the ground level by two steps. It consists of one main confined area used for food preparation, and cooking.

The store

The store is of slightly rectangular shape. It is raised above the ground level by two steps. It consists of one main confined area used for storing grains, dates, etc. ...

The servant's room

The servant's room is of a rectangular shape. It is raised above the ground level by two steps. It consists of two main confined areas; the first is the servant's bedroom, and the second is the servant's bathroom.

The animals shed

The animals shed is of arectangular shape. It is raised above the ground level by two steps. It consists of one main confined area used for both keeping the goats and sheep, and for the fodder storage.

The car park

The car park is of a rectangular shape. It is raised above the ground level by two steps. It consists of one main confined area used for parking one car only.

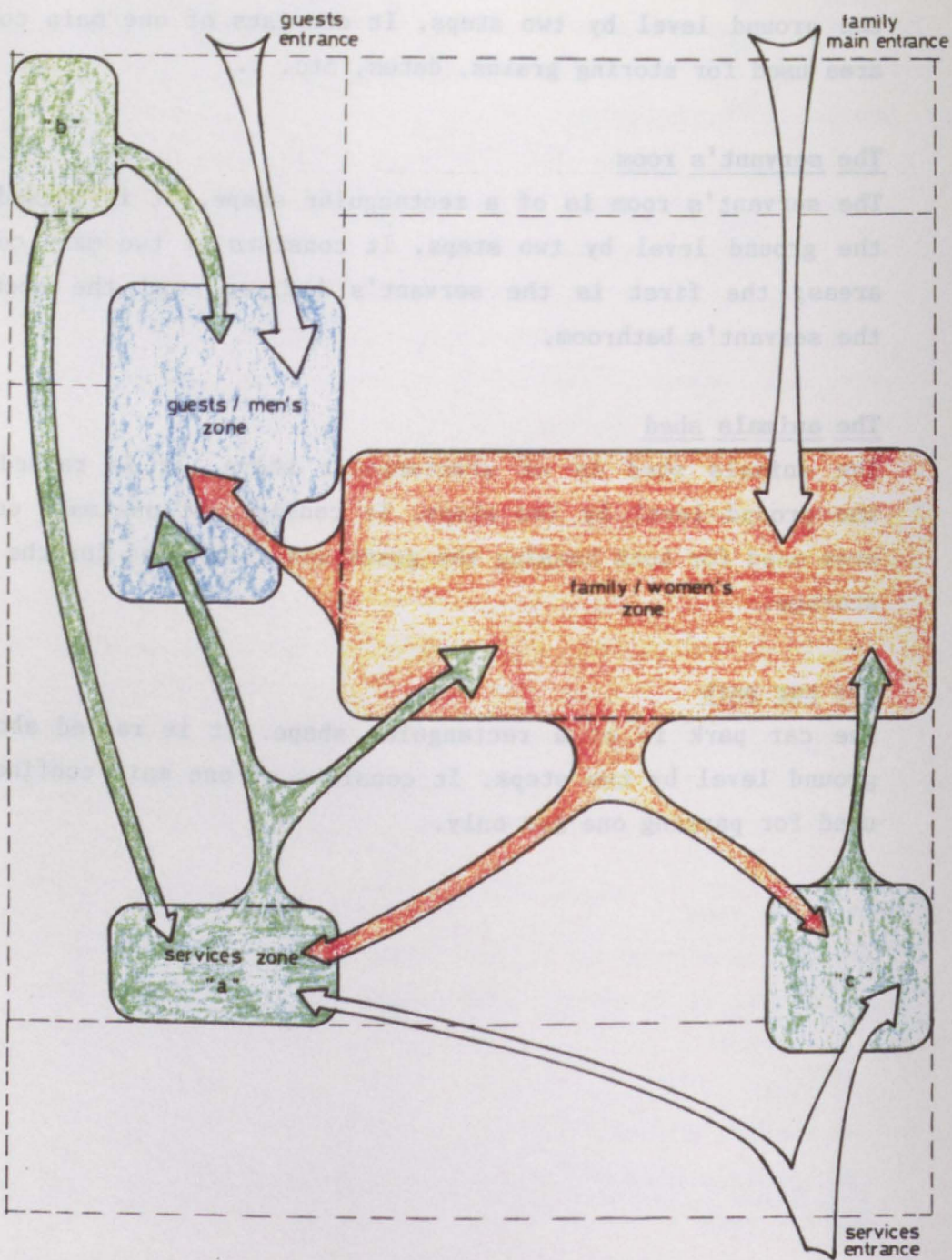
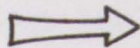

Fig. 105 : A diagram that shows the flow of circulation between the different zones of the house.

Note :



this arrow shows the direction of the main flow of circulation between the different zones of the house.

Functional Aspect

This type of house is divided into three main zones (see Fig. 104). Each one of these zone has a certain function. They are as follow:

1) Family / women's zone

It contains three family bedrooms and three bathrooms. Disregarding the family size to which the house was granted, the family members share the three bedrooms.

2) Guests / men's zone

It contains the male guests reception called "al'Majlis", where male members of the family receive their guests. It also contains a bathroom.

3) Services zone

It contains all the services that are required to assist life in the house, such as : a kitchen, a store, an animals shed, a car park and a seravnt's room.

These zones are laid out together in order to maintain the rquired functional performance of each one. Their layout guarantes an uninterrupted flow of circulation between them (see Fig. 105).

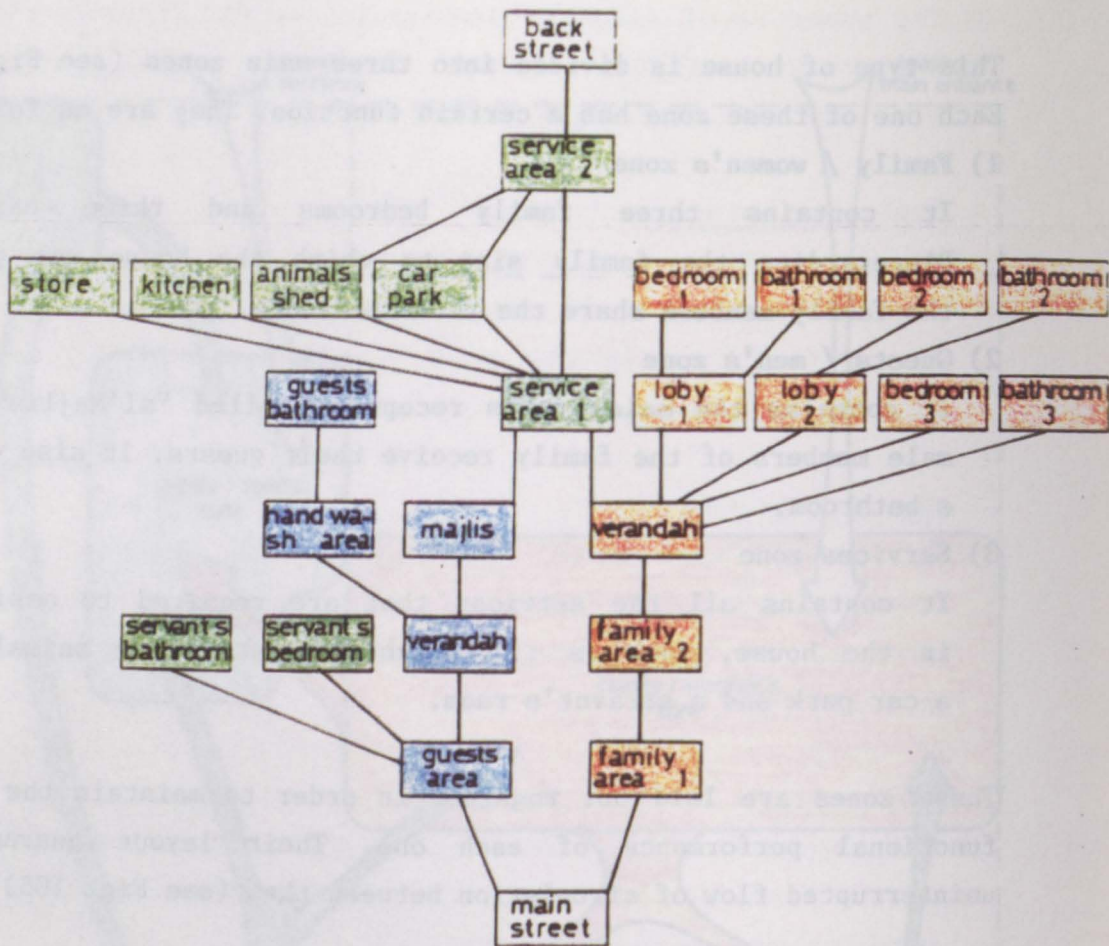
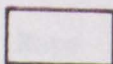

Fig. 106 : A map that shows the hierarchical spatial organisation of the low-income house type 2.

Note : This map is based on the direct accessibility from one space to the other, and on the method of the justified gamma maps (4).

Key :



a space in the house



one step = a movement from one space to another

In figure 106 the house is divided into a number of layers based on the equal number of movements leading to different spaces among it. This number of movements is in relation to the public space, in this case is the street. The more number of movements needed to reach a certain space inside the house, the deeper this space is. Spaces having a certain depth, therefore lying in the same layer, possess a certain degree of permeability. Beginning from the street, the penetration of the house spatial pattern is controlled. This is by providing the house with three functional links to the public space. The first link is the guests entrance leading to "al'Majlis". The depth of "al'Majlis" has remarkably increased compared to traditional types of houses in Abu Dhabi. The second link is the family entrance leading to the family bedrooms. The family bedrooms do not lie in the same layer of the house, where the third bedroom lies in the same layer as the lobbies leading to the other two bedrooms. An unexplained design decision. The third link is the services entrance. A new feature in the houses built in Abu Dhabi. It leads to the various fragments of the services zone. Contact between these three functional links, and the house zones is maintained through the fragmented outdoor private spaces.

Figure 107 (a,b,c) shows the main spaces of the house. A graphic interpretation of the division of spaces in accordance to the different activities carried out in them is also shown. The actual areas of spaces are neglected. Some of the spaces of the house are characterised by being multi-functional spaces, such as "al'Majlis". Other spaces are single-functional spaces such as the store.

Figure 107 (a,b,c) shows the main spaces of the house. A graphic interpretation of the division of spaces in accordance to the different activities carried out in them is also shown. The actual areas of spaces are neglected. Some of the spaces of the house are characterised by being multi-functional spaces, such as "al'Majlis". Other spaces are single-functional spaces such as the store.

SPACE TITLE	ACTIVITIES CARRIED OUT IN THE SPACE	GRAPHIC INTERPRETATION
Bed room	= Sleeping	
Servant	= Bedroom (sleeping).	
Al'Majlis	= GUEST RECEPTION = [sitting & dining]	
Loby	= Circulation distribution, either to the bedroom or to the bathroom	

Fig. 107(a) : A table that shows the different activities carried out in the different spaces of the low-income house type 2, and their graphic interpretation.

Fig. 107 (b)

SPACE TITLE	ACTIVITIES CARRIED OUT IN THE SPACE	GRAPHIC INTERPRETATION
Kitchen	= Cooking and food preparation	
Verandah	= TERRACE + CIRCULATION (outdoor sheltered sitting space)	
Store	= STORE (food storage)	
Animals Shed	= FODDER + ANIMALS SHELTER	

SPACE TITLE	ACTIVITIES CARRIED OUT IN THE SPACE	GRAPHIC INTERPRETATION
Car Park	= A shaded area suitable for parking only one car.	
Bath room	= Bathing • Ablution • W.C.	

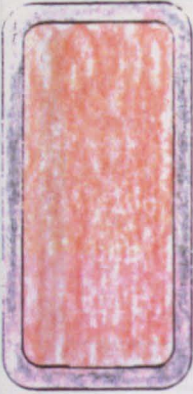
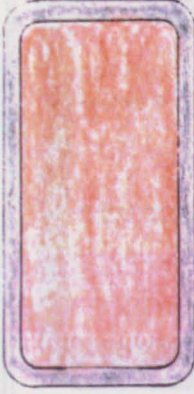
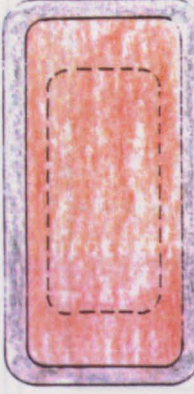
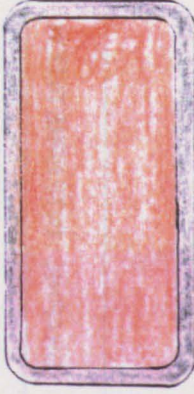
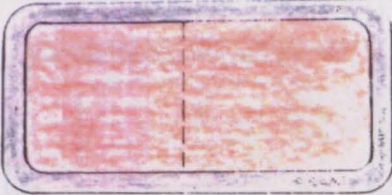
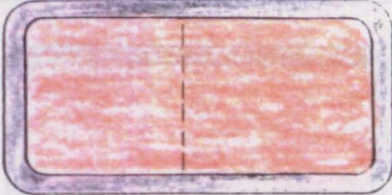
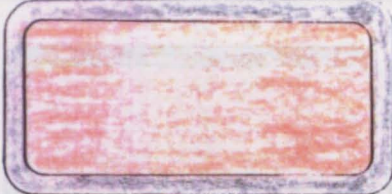
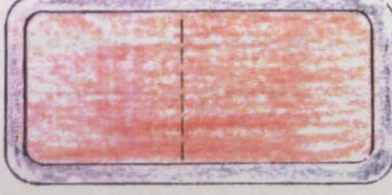
Fig. 107 (c)

Conclusion

The low income house type 2 consists of three main zones which are:

- 1) Family / women's zone
- 2) Guests / men's zone
- 3) Services zone

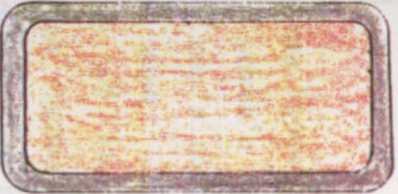
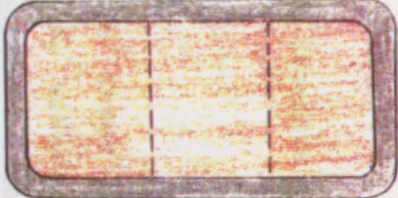
The layout of the house three zones maintains the required accessibility between them, without obstructing one circulation flow the other. The representation and analysis of the permeability structure of the house feature a multi-hierarchical spatial organisation, which is highly impermeable to strangers. Spaces among the house are either single-functional or multi-functional spaces. Combined functions, previously separated in traditional house types (see Bait al'Sahel), such as bathing, ablution and the w.c. in one bathroom. Spaces requiring the same degree of privacy, thus a certain depth among the house, are laid in layers with different depths. On the other hand, the depth of "al'Majlis" has remarkably increased. Compared to that of "Bait al'Sahel", for instance, its depth nearly tripled where it used to be a very shallow space in the house.

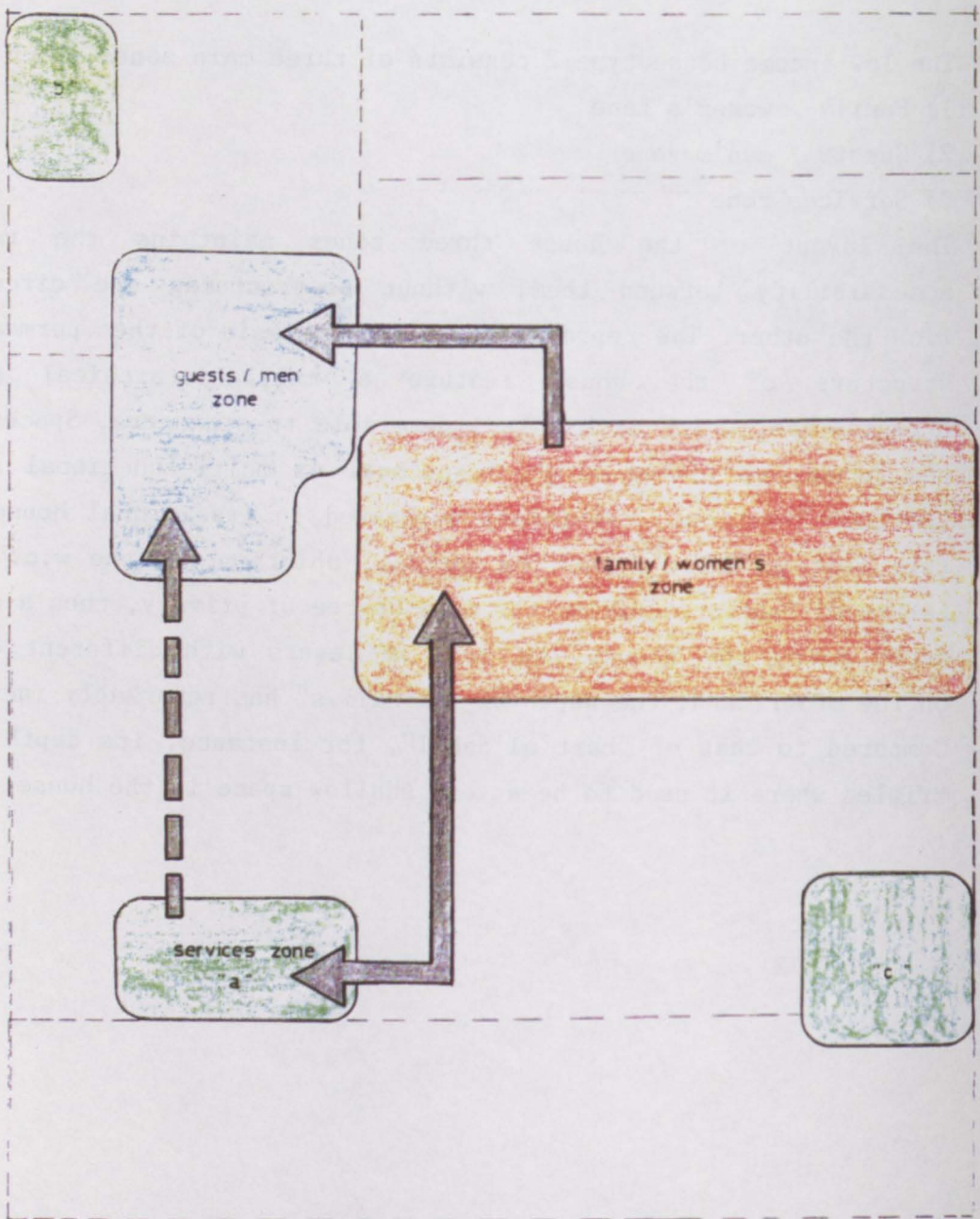





Fig. 100 : A diagram that shows communication degrees between the house different zones.

Key :

-  mutual and dense
-  single and frequent
-  single and infrequent

Socio-cultural Aspect

The design of the low income house type 2 is an attempt to interpret the social behaviour patterns of the local households. The communication between the different zones of the house is maintained (see Fig. 108), where it is partially governed by the degree of privacy they require. Therefore achieving incomplete privacy for the spaces of each zone (see Fig. 109). For instance, bedroom 3 requires the same degree of privacy of the other two bedrooms, but it possesses the same degree of privacy as the other bedrooms lobbies. It is directly exposed to audio/visual inspection from the verandah. Bathroom 3 is also exposed to audio/visual inspection from the verandah, where other bathrooms possess higher degrees of privacy.

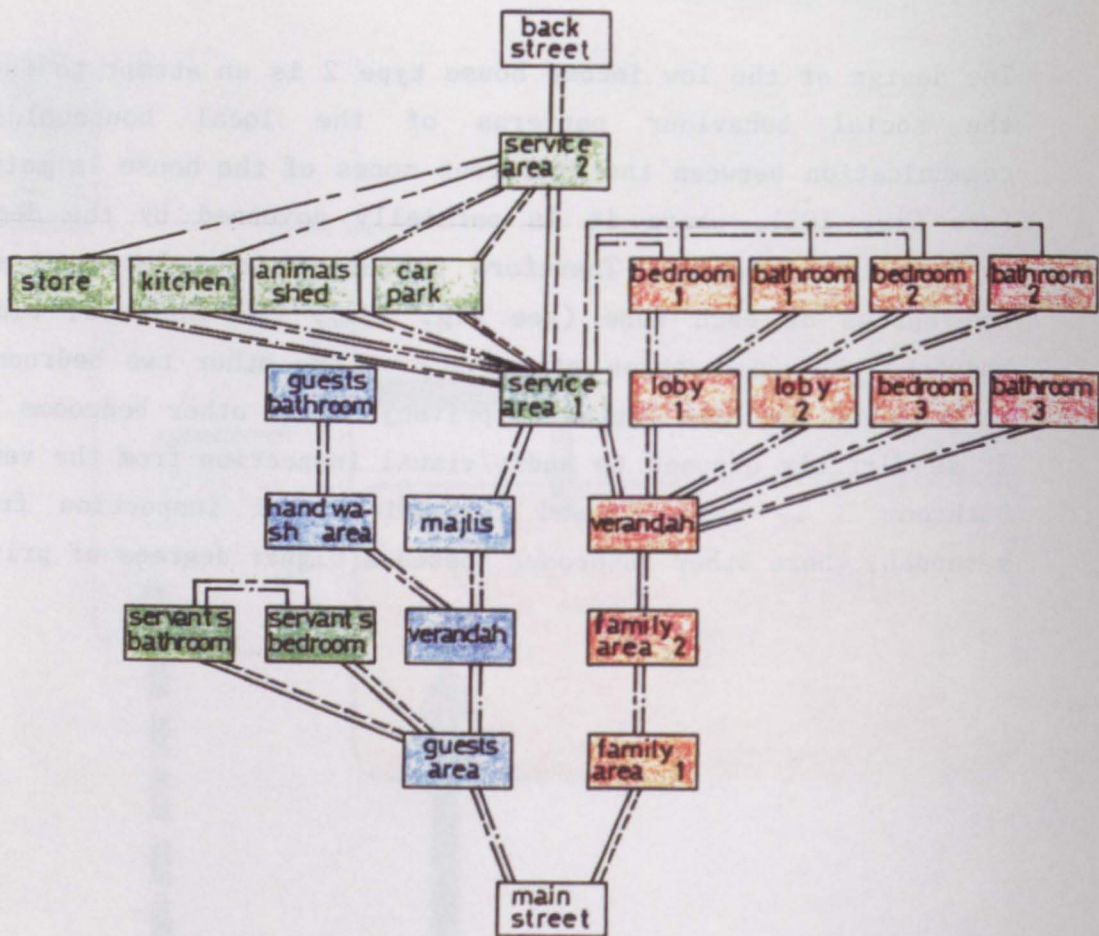

Fig. 109 : A map that shows the types of communication between different spaces in the house.

Note : This map is based on the immediate audio/visual inspection from any space on the next permeable one (5).

Key :

- a space in the house
- direct aural
- indirect aural
- direct visual
- indirect visual

The layout of the low income house type 2 shows fragmented outdoor private spaces as front and backyards more than a courtyard. Eventhough they are separated by dividing boundary walls 2.8 metres high, audio/visual inspection between the house zones and their spaces is not prevented. For example:

- Direct audio/visual inspection from the street on the first family / women's outdoor area is not prevented.
- Direct audio/visual inspection from the guests bathroom and the hand washing area, on the family / women's second outdoor space and verandah is not prevented.
- Direct audio/visual inspection from the guests / men's outdoor area on the servants bedroom is not prevented. Noting that 50% of the servants employed by the local families in the emirate of Abu Dhabi are females, thus the location of servants room is a failier in 50% of this type of house (25).

Conclusion

This type of low-income house provides its households with incomplete privacy. Eventhough the house is provided with three separate entrances, divided into three different zones, and surrounded by double boundary walls 2.8 metres high, the family members can not carry out their every day lives in absolute privacy.

Current "U" values:

1. The roof = $0.11 \text{ w/m}^2 \text{ } ^\circ\text{C}$
2. The wall = $2.31 \text{ w/m}^2 \text{ } ^\circ\text{C}$
3. The Window = $5.60 \text{ w/m}^2 \text{ } ^\circ\text{C}$

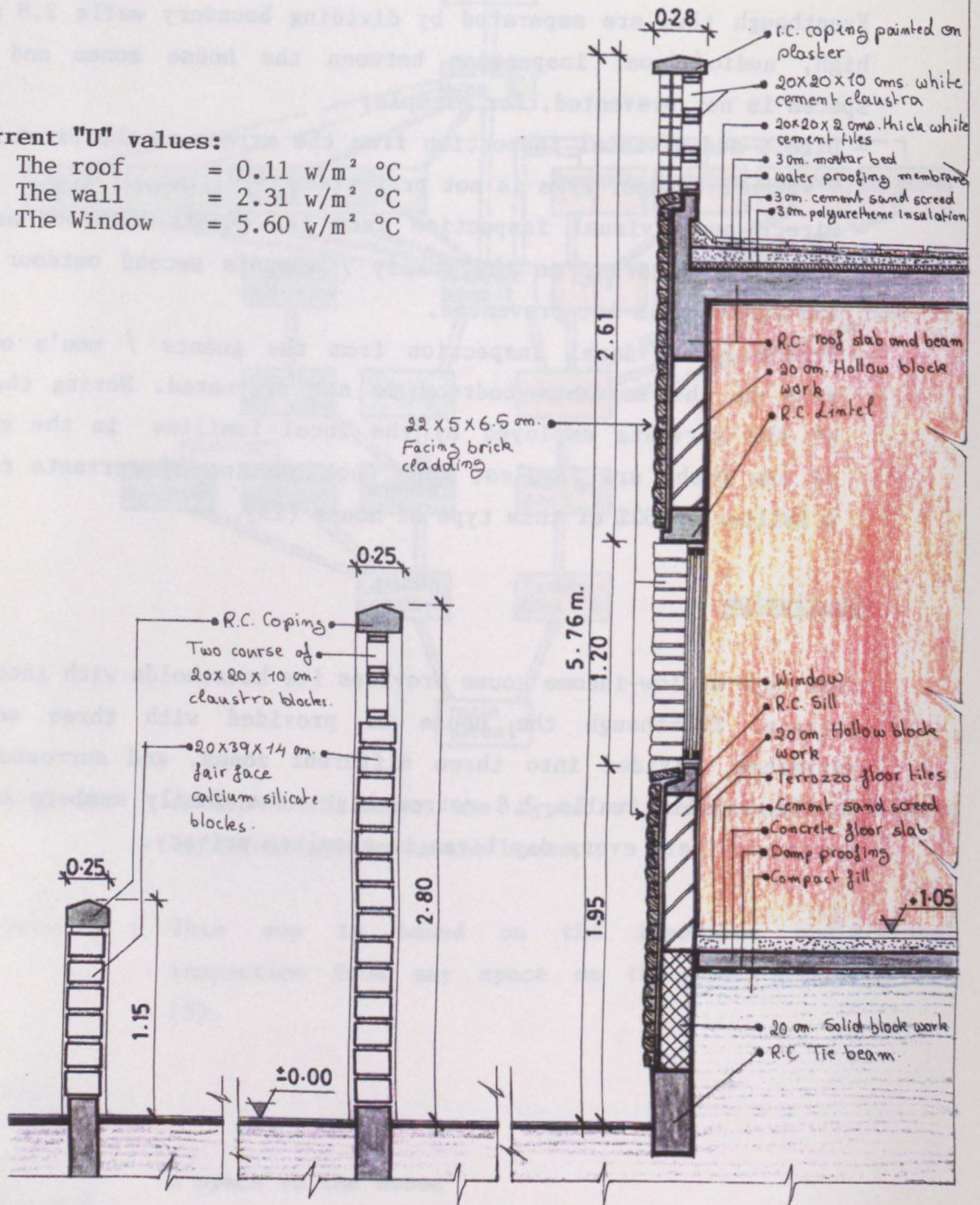

Fig. 110 : A sketch that shows a transversal section passing through the low-income house type 2 (26)

Note : *The polyurethane thermal insulation deteriorates on the long run because of very high temperature degrees.
 *The "U" values of the roofs, walls and windows are very high regarding the climatical conditions of Abu Dhabi, see proposed "U" values by the author on page 208B , Fig. 51

Technical Aspect

The process of building this type of low income house was carried out utilising contemporary building materials, and applied construction methods. The house is constructed with column and beam structure system (see Fig. 110). It is raised seven steps above the ground level, except for the services zone which is raised only two steps above the ground level. Walls are built of 20x20x40 cm. concrete hollow block work. The interior faces of the walls of the bedrooms, "al'Majlis", verandahs, staircase, store, lobies and servants room are finished with cement/sand plaster and paint. Their floors are finished with terrazzo floor tiles, and their ceilings are finished with cement/sand plaster and paint. The interior faces of the walls of the kitchen, bathrooms, hand washing area and toilets are finished with glazed wall tiles. Their floors are finished with non-slip ceramic floor tiles, and their ceilings are finished with cement/sand plaster and paint. All the apparent exterior walls of the house are cladded with split calcium silicate bricks of off-white colour. Other exterior walls are finished with cement/lime/sand plaster and paint, colours are of the architect's choice. All windows are single glasing slyding type, where all doors are wooden flush doors. Entry gates are made of steel. All the verandahs, and roof parapets are of thick white cement claustra. The claustra patterns and colours are of the architect's choice. All roofs are finished with white cement tiles (see Fig. 110 for roof layers). All external passage ways are finished with precast coloured interlocking concrete paving blocks. Finally all boundary walls are built up with 20x39x14 cm. fair face white calcium silicate blocks.

Conclusion

The process of constructing this type of low income house is carried out applying simple contemporary construction method. It utilises contemporary building materials available in the local market.

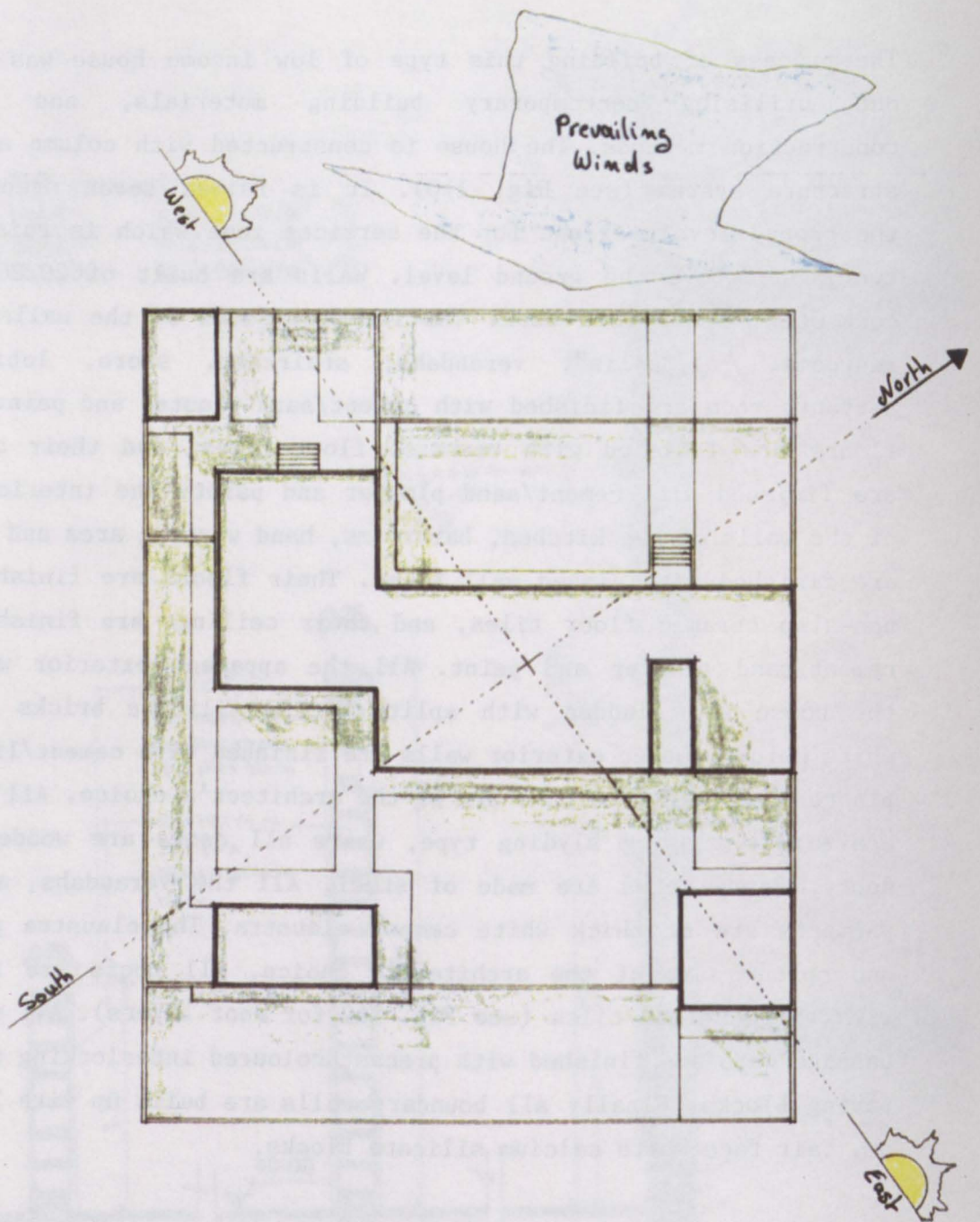

Fig. 111 : A sketch that shows the orientation of the low-income house type 2.

Environmental Aspect

Regarding the severe environmental conditions of Abu Dhabi's coastal areas, this type of low income house does not adapt efficiently to the local environment. This is due to the incomplete consideration of the following:

- 1) The shape and orientation of the buildings
- 2) The natural cross ventilation
- 3) The sun protection

1) The shape and orientation of the buildings

Eventhough the buildings of the house are of proportionate rectangular shapes, some of them are badly oriented such as the guests / men's buildings, the servants room and the car park. Buildings properly oriented, such as the family bedrooms, will provide a considerable shaded area to the family outdoor open space (see Fig. 111).

2) The natural cross ventilation

The natural cross ventilation of the house is badly achieved due to the following:

- The badly located windows. All the walls, of both the family / women's buildings and the guests / men's buildings, which are facing the prevailing winds direction are completely solid. The only space that has a narrow air inlet facing the prevailing winds, and a wider air outlet is the bathroom 3. In this case, bad implementation of the cross ventilation system will result in the transfusion of the bad odours to other spaces of the house.
- The servants room has only one window, which is located in the wall parallel to the direction of the prevailing winds.
- The kitchen is provided with two clear storey windows. The first faces the prevailing winds, while the second is located in the opposite wall across the kitchen area. This will provide cross ventilation, but not for the kitchen area designated for cooking.

Regarding the better environmental conditions of the host's country, this type of low income house does not adapt efficiently to the local environment. This is due to the inadequate orientation of the following:

- 1) The shape and orientation of the building
- 2) The natural cross ventilation
- 3) The roof protection

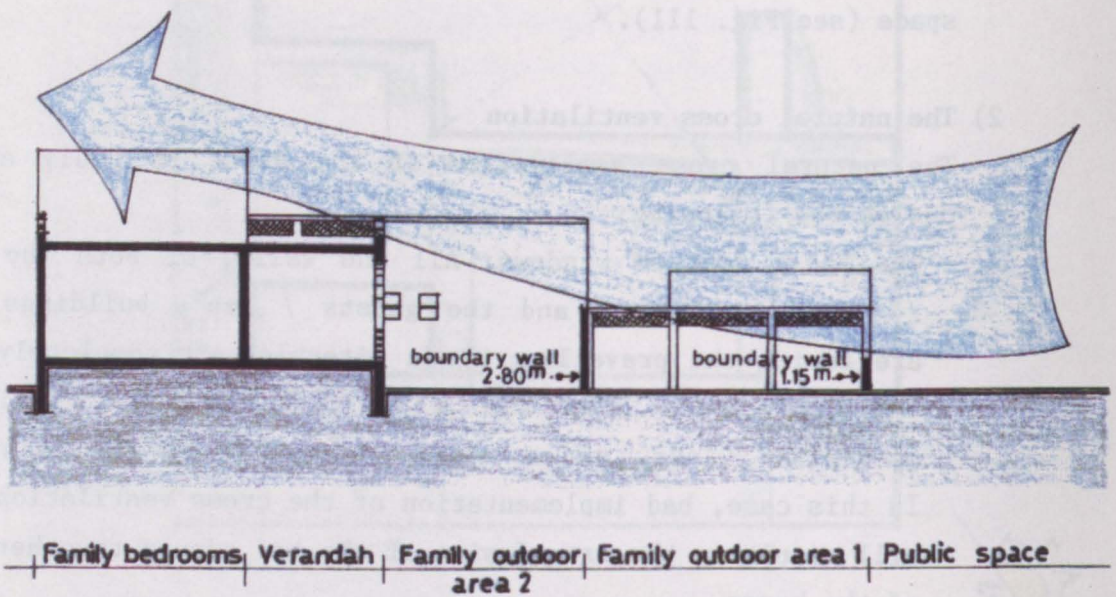

Fig. 112 : A sketch that shows the air flow pattern around the low-income house type 2.

- The store does not have windows facing the prevailing winds. It has one clear storey window located on the opposite wall. In order to maintain cross ventilation the store door has to be kept open.
- Air channeling around the house buildings and in the outdoor areas is totally neglected. The progressing height of the boundary walls of the house facing the prevailing winds direction, the distance between them and the house buildings forces the winds to climb to higher levels (see Fig. 112).

3) Sun protection

The design of this type of low income house does not provide complete sun protection, due to the following:

- Most of the windows of the house are not only wide and shallow, but also facing either west or south. Highly unrecommended orientation for unprotected windows.
- The unemployment of neither sun screens nor sun breakers, aggravates the effect of the direct sun rays on the interior of the house spaces. Semi-enclosed areas such as the verandahs which can act as perfect sun protection elements, are located on the opposite side from the walls carrying the windows.
- The walls thicknesses are variable due to the decorative wall cladding of some of them. The first impression is that walls are cladded for sun protection reasons. In reality only external walls apparent on the main elevations of the house are the cladded ones. Brick cladding is used only as a decorative element, where other buildings such as the kitchen, the store and the servant's room are not cladded at all.
- Thermal insulation is incomplete. While roofs have poor thermal insulation (U value = $0.11 \text{ w/m}^2\text{°C}$) walls are not, taking into consideration the ratio of the roof surface area to that of the walls.

Conclusion

This low income type of house does not provide comfortable living conditions. Natural cross ventilation is generally not implemented. Eventhough most of the buildings of the house are properly oriented, sun protection is not completely achieved. Essential air channelling around the house buildings is not maintained. Incomplete implementation of thermal insulation, wherefore the house does not efficiently adapt to the local climatical conditions of its surrounding environment.

2 . 3 P o s t - o c c u p a n c y h o u s i n g s u r v e y c a r r i e d o u t b y t h e P l a n n i n g D e p a r t m e n t o f A b u D h a b i

In fulfilment with the aim of the housing policy, developed by the government of Abu Dhabi, to provide the local people with convenient houses. The Planning Department of Abu Dhabi was assigned by the executive council to carry out a post-occupancy housing survey. The theme of this survey is the evaluation and the enhancement of the conveniency of the houses granted to the local people so far. This housing survey was carried out through the period from the 1st of March 1987 until September 1987. Utilising the main frame computer of the Finance Department of Abu Dhabi, the final results were sorted out in March 1988. These results reflect the actual needs of the local people. The Planning Department emphasises on the importance of taking these results into consideration when designing new low income housing schemes.

2.3.1 The survey methodology

This survey was carried out by a randomly selected uniform clustered sample, 10% of the low income houses built in each of the following areas of Abu Dhabi:

- Abu Dhabi city urban area
- Abu Dhabi city rural area
- Al'Ain city urban area
- Al'Ain city rural area

The total number of houses forming the sample and is subject to the survey is 1268 houses.

2.3.2 The aims of the survey

The aims for which this survey was carried is the identification of the following:

- 1- The actual constituents of the low income houses regarding the number of rooms, living rooms, kitchens, bath rooms, verandas, stores, garages and animal sheds. Hence, regestring the local people's opinions regarding the efficiency of each one of them.
- 2- The number and type of the house constituents added by the owners to the original design after occupying the house.
- 3- Some of the demographic, social, and economical properties of the households.
- 4- The design programme essential components that are to be achieved by the future low income housing schemes.

2.3.3 The principal indications of the housing survey

There are four principal indications of the housing survey, which are:

- First : General indications
- Second : Some of the sample characteristics
- Third : The low income house constituents
- Fourth : The animals sheds in the low income houses

First : General indications

- Only 87% of the owners occupy their low income houses.
- 1% of the total number of low income houses forming the survey sample were demolished and rebuilt differently.
- 82% of the households complain of the insufficient water tanks actual capacities (400, 600, 800 gallons).
- 59% of the households find that the main entrance of the house is inconvenient regarding its shape, form and material.
- 62% of the households increased the boundary wall height, where 69% of them find the convenient height is 3 - 3.5 m.
- 89% of the households find the concrete hollow block work suitable for the construction of the house regarding the environmental conditions. Whereas 59% find that the precast concrete walls and slabs are not suitable.

Second : Some of the sample characteristics

- The average size of the local families occupying the low income houses is 8 persons.
- The marital status of the family members, where 34% of the males and 21% of the females are not married. Future excess need of houses for the already housed families.
- The number of servants or drivers employed by the local families forms 10% of its total number of members.

Third : The low income house constituents

Bedrooms

- 50% of the households did not have sufficient number of bedrooms when they first occupied the house. Whereas the ratio of the added number of bedrooms to the original is 78%.
- 65% of the households find the master bedroom area insufficient, and 64% find the children's bedroom area insufficient.

The Majlis

- A family / women's majlis has been added by the families to 57% of the low income houses.
- 53% of the households find that the majlis area is insufficient.

Bathrooms

- While bathrooms have been added to 53% of the low income houses, only 34% of the households do not find their location next to the bedroom suitable.
- 75% of the households do not find the bathroom area suitable.

Kitchens

- 79% of the households find that one kitchen in the house is enough, while 21% do not.
- 78% of the households do not find the kitchen area suitable.

Stores

- 100% of the households added stores to their houses because of the family needs according to its size, or that the original store is small, or that the house did not initially include any stores.

Garages

- 64% of the houses did not include garages.
- 100% of the households added a garage or more either because there was not any or because of the number of cars they own.

Fourth : The animals sheds in the low income houses

- 39% of the households grow domestic animals, while 61% do not.
- 63% of the households who grow domestic animals did not initially have animals shed in their house.
- The average number of domestic animals / family is 20heads.

2.3.4 Recommendations

In reference to the principal indications of the housing survey, the Planning Department of Abu Dhabi emphasises on considering its recommendations concerning the following:

The low income house constituents :

- an average of four bedrooms including the servant's.
- two majlis; a family / women's majlis and a guests / men's majlis.
- an average of four bathrooms one of them serving the guests / men's majlis.
- one kitchen located outside the house main buildings and next to the servant's room.
- one store adjacent to the kitchen.
- a garage suitable for parking two cars.
- an animals shed for the houses built in the rural areas.

The areas of the low income house constituents

- The master bedroom to be of 30 sq. m. (6x5 m.).
- The children's bedrooms each to be of 25 - 30 sq. m. (5x5 or 6x5 m.).
- The guests / men's majlis to be of 48 sq. m. (8x6 m.).
- The family / women's majlis to be of 30 - 35 sq. m. (6x5 or 7x5 m.).
- The family bathrooms to be of 9 sq. m. (3x3 m.), and any others to be of 6 sq. m. (3x2 m.).
- The kitchen to be of 16 - 20 sq. m. (4x4 or 5x4 m.).
- The animals shed to be suitable for keeping 20 heads.

The house building materials

The low income houses to be constructed utilising concrete hollow block work, and not precast concrete walls & slabs.

Family size	Bed rooms	Majlis/ living rooms	Kitchen	Bath rooms	Store	Garage	Remarks
1 - 3 number area	1 4 x 5	1 5 x 6	1 3 x 4	2 3 x 3 2 x 3			for widows & devorced = 8%
4 - 6 number area	2 5 x 6 5 x 6	2 6 x 8 5 x 6	1 4 x 4	3 3 x 3 2 x 3 2 x 3	1 3 x 3	1 one car	= 20%
7 - 9 number area	3 5 x 6 5 x 6 5 x 6	2 6 x 8 5 x 6	1 4 x 4	4 3 x 3 3 x 3 2 x 3 2 x 3	1 3 x 4	1 two cars	= 28%
10 & + number area	4 5 x 6 5 x 6 5 x 5 4 x 5	2 6 x 8 5 x 6	1 4 x 5	5 3 x 3 3 x 3 3 x 3 2 x 3 2 x 3	1 4 x 4	1 two cars	= 44%

Fig. 113 : A table that shows the recommended low-income house types and their constituents with respect to the corresponding family sizes.

The water tanks

The water tanks are to be of 800 gallons or more, and to be made of fibreglass or galvanised steel.

The boundary walls

The boundary walls height to be of 3 - 3.5 m.

The widows and the devorced

Include small houses of two rooms in the low income house types for the widows and the divorced.

The future expansion

Prepare low income house designs that allow the future expansion of the house without affecting neither the original design nor the house structure and soundness.

The low income house types

Figure 113 is a table which shows the four types of low-income houses recommended by the Planning Department of Abu Dhabi, with respect to the family different sizes.

2 . 4 C o n c l u s i o n

The previous analytical study of the (social, environmental, etc. ...)feasibility of the houses built before and after the discovery of oil in the emirate of Abu Dhabi, leads to the fact that: as the traditional types of houses have common characteristics, the low income houses have common characteristics too.

2.4.1 Common characteristics of the traditional houses

The common characteristics of the traditional houses built in Abu Dhabi before the discovery of oil are:

1. They are generally divided into three main functional zones; Family / women's zone, guests / men's zone, and services zone. Most of the spaces which these three zones consist of, if not all, are multi-functional spaces. They are laid out together in a deep, highly impermeable, hierarchical spatial organisation.
2. The immediate audio/visual inspection, from any of these spaces on the next permeable space, is governed by the degree of privacy that each space requires. Family members, especially women, have absolute privacy in most of the traditional houses.
3. The traditional houses have been built utilising the available natural building materials available in the local environment of Abu Dhabi. The local builders applied traditional building methods in constructing these types of houses.
4. The traditional houses adapt to the local environmental conditions, offering the local people comfortable living qualities. This is the passive building system, which means building with the climate (27).
5. The traditional houses were built with local building materials, with strict limitations on importing few others needed. The cost of

construction per square metre was 100 Derhams, the sum equivalent to 14 Pounds Sterling.

6. The traditional houses designs include natural esthetical values. This was due to the implementation of functional decorative elements. Wherefore, in general, the traditional houses integrate the picture of their local surroundings.
7. The law and the building regulations, applied in the construction of the traditional houses, are the simple knowledge of the capabilities of these materials and the know how to assemble them together. Yet, these houses are the most convenient for the local people.

2.4.2 Common characteristics of the low income houses

The common characteristics of the low income houses built in Abu Dhabi after the discovery of oil are:

1. Some of the low income houses are divided into two zones only; Family / women's zone, and serviecs zone. Whereas some others are divided into three main zones; the above mentioned in addition to the guests / men's zone. Some of the spaces, which these zones consists of, are multi-functional spaces, and some are single-functional ones. They are laid out in spatial organisations of different forms, some of which perform a certain hierarchy. Some others are of very shallow spatial organisations.
2. Immediate audio/visual inspection, from any of the house spaces on the next permeable one, is not always governed by the degree of privacy each one requires. Therefore absolute privacy for the family members is not achieved.
3. The low income houses are built with contemporary building materials, and applying contemporary methods of construction.

4. The low income house designs ignore completely the local environmental conditions. Depending on the latest technology in air conditioning, efficient window type air conditions cool the inside of the house. This is the active building system, which means living and building in spite of the climate (27). They also generate excessive heat outside the houses in the hottest periods of the day.
5. The low income houses are built with locally produced building materials, a considerable amount of others are imported. The cost of construction/ m² varies between 950 - 1200 Derhams, the equivalent sum of 140 - 175 Pounds Sterling. The construction cost/m² is quite irrelevant where houses are provided for low income people without charges.
6. The low income houses artificial esthetical values are subject to personal judgments. They are implemented mostly to decorate the house elevations according to the architect's taste. Generally the houses do not integrate the picture of their local surroundings.
7. The building regulations, applied in constructing low income houses, are said to be the British Standards for design and construction. If so, which BS and of which edition on which date.

Comparing both sets of common characteristics to each other, explains the reasons why the low income house types have not been successful in meeting the needs of the local people so far. This is due to the lack of knowledge on the socio-cultural background of the local people, their social behaviour patterns, and their every day needs. The influence of the various foreign cultural backgrounds of the architects involved in preparing the low income housing schemes. The negligence of the local environmental conditions depending on modern technology. This resulted in a series of trial and error attempts to design convenient dwelling units for the local people. Taking into consideration the results and the recommendations of the post-occupancy housing survey, will help in developing the dwelling unit standards. Therefore, developing layout parameters which will be carried out in chapter four.

List of Quotations

- (1) Faegre, T., "Tents-Architecture of the Nomads", London, 1979, pp 18-25
- (2) El'Abdouly, K. G., "Prevailing Trends in the Architecture of the United Arab Emirates" Abu Dhabi, 1989, p 44
- (3) Reproduction by the author from : Faegr, T., "Tents", p 24
- (4) Hillier, B. & Hanson, J., "The Social Logic of Space", London, 1984, pp 147 - 152
- (5) Broadbent, G., "Design in Architecture - Architecture and the Humman Sciences", London, 1973, pp 262, 263
- (6) Reproduction by the author from : Faegr, T., "Tents", p 19
- (7) *ibid*, p21
- (8) Reproduction by the author from : El'Aboudy, N. H., "Studies on the United Arab Emirates Heritage and Archeology", Abu Dhabi, 1990, p 174 (Title translated by the author).
- (9) El'Abdouly, K. G., "Prevailing", pp 178 - 183
- (10) *ibid*, p 52 - 61
- (11) Heard-Bey, F., "From Trucial States to United Arab Emirates", London, 1984, p 439
- (12) *ibid*, p 246
- (13) Information on the method of construction of "Bait al'Sahel" are gathered by the author through personal interviews and meetings with local people, and Matloob, A., the responsible for the renovation of a similar house type in Dubai, Abu Dhabi, 1989 & 1990
- (14) El'Abdouly, K. G., "Prevailing", pp 53 - 61
- (15) El'Aboudy, N. H., "Studies on the", pp 146 - 164
- (16) El'Abdouly, K. G., "Prevailing", pp 81 - 95
- (17) El'Aboudy, N. H., "Studies on the", pp 104
- (18) Kay, S. & Zandi, D., "Architectural Heritage Of The Gulf", Dubai, 1991, p 21
- (19) Afifi, A. K. & Sarhan, A., "Climatical conditions and their influence on the urban design in the United Arab Emirates", a research paper, Al'Ain - Abu Dhabi, 1985, pp 5 - 7 (Title

- a research paper, Al'Ain - Abu Dhabi, 1985, pp 5 - 7 (Title translated by the author - Not published).
- (20) Ramzy, Sleeper, "Architectural Graphic Standards", 7th ed, New York, 1981, pp 111, 112
- (21) Reproduction by the author from: Ibrahim, M. A., "The Gulf Architecture Between Originality And Renovation", Part Two, Cairo, 1972, p 99 (Title translated by the author).
- (22) *ibid*, p 96
- (23) Reproduction by the author from: Salmani, T. M. A., "Privacy In Housing - Perception And Applications In Islamic Architecture", a research paper, Abu Dhabi, 1989, pp 16 - 18 (Not published)
- (24) Reproduction by the author from: Public Works Department - Emirate Of Abu Dhabi, "10 nos. Low Cost Houses", project no: 1-1-416/1R, drawing no: A/22, Abu Dhabi, 19/9/1987 (Not published).
- (25) Department of Planning, "Post-Occupancy Housing Survey", Abu Dhabi, 1987, p 67 (Title translated by the author - Not published).
- (26) Reproduction by the author from: Public Works Department - Emirate Of Abu Dhabi, "10 nos. Low Cost Houses", project no: 1-1-416/1R, drawing no: A/24, Abu Dhabi, 24/9/1987 (Not published).
- (27) Holm, D., "Energy Conservation In Hot Climates", London, 1983, p 25

List of Figures

- Figure 2/1 : A photograph that shows the house of hair.
- Figure 2/2 : An example for "Biute al'Badu" - Houses oh Hair.
- Figure 2/3 : A diagram that shows the different zones of "Biute al'Badu".
- Figure 2/4 : A photograph, shot by the author, that shows "Al'Zeribah".
- Figure 2/5 : A photograph, shot by the author, that shows "Al'Talal".
- Figure 2/6 : A photograph, shot by the author, that shows "Al'Towey".
- Figure 2/7 : A photograph, shot by the author, that shows "Al'Towey".
- Figure 2/8 : A diagram that shows the flow of circulation between the different zones of the house.
- Figure 2/9 : A map that shows the hierarchical spatial organisation of "bait al'badu".
- Figure 2/10 : A table that shows the different activities carried out in the different spaces of "bait al'badu", and their graphic interpretation.
- Figure 2/11 : A diagram that shows communication degrees between the house different zones.
- Figure 2/12 : A map that shows the types of communication between different spaces of the house of "bait al'badu".
- Figure 2/13 : A sketch that shows the tent cloth.
- Figure 2/14 : A sketch that shows a transversal section passing through the tent, and parallel to the dividing curtain wall.
- Figure 2/15 : A sketch that shows various types of stay fasteners.
- Figure 2/16 : A sketch that shows the curtain walls pinned to the tent roof.
- Figure 2/17 : A sketch that shows the orientation of the tent of the "house of hair".
- Figure 2/18 : A sketch that shows the natural cross ventilation of the tent of the "house of hair".
- Figure 2/19 : A sketch that shows how "Biute al'Sahel" were laid

out together, and the width of "al'seccah".

- Figure 2/20 : An example for "Khaimat al'Saaf" - the palm-frond tent.
- Figure 2/21 : A diagram that shows the different zones of "Khaimat al'Saaf".
- Figure 2/22 : A photograph that shows the family living rooms, and the palm-frond double door.
- Figure 2/23 : A photograph that shows "Al'Manamah".
- Figure 2/24 : A photograph that shows the wind tower constructed on the roof of "Al'Liwan".
- Figure 2/25 : A diagram that shows the flow of circulation between the different zones of the house.
- Figure 2/26 : A map that shows the hierarchical spatial organisation of "Khaimat al'Saaf".
- Figure 2/27 : A table that shows the different activities carried out in the different spaces of "Khaimat al'Saaf", and their graphic interpretation.
- Figure 2/28 : A diagram that shows communication degrees between the house different zones.
- Figure 2/29 : A map that shows the types of communication between different spaces of "Khaimat al'Saaf".
- Figure 2/30 : A sketch that shows a transversal section passing through "Khaimat al'Saaf".
- Figure 2/31 : A sketch that shows the orientation of the palm-frond tent.
- Figure 2/32 : A sketch that shows the natural cross ventilation of the palm-frond tent.
- Figure 2/33 : An example for "Bait al'Sahel"; the ground floor plan.
- Figure 2/34 : A diagram showing different zones of "bait al'sahel".
- Figure 2/35 : A photograph that shows the family entrance, and inset is the photograph of the guests entrance.
- Figure 2/36 : A sketch showing the plan of "al'makhzan".
- Figure 2/37 : A photograph of a "liwan".
- Figure 2/38 : A sketch showing a section through the family zone.
- Figure 2/39 : A photograph showing "al'wadesh" and "al'barjeel".
- Figure 2/40 : A sketch showing the plan of "al'majlis".

- Figure 2/41 : A sketch showing "al'bakhar".
- Figure 2/42 : A diagram showing the flow of circulation between different zones of the house.
- Figure 2/43 : A map showing the hierarchical spatial organisation of "bait al'sahel".
- Figure 2/44 : A table showing the different activities carried out in different spaces of "bait al'sahel", and their graphic interpretation.
- Figure 2/45 : A diagram showing communication degrees between the house zones.
- Figure 2/46 : A map showing the types of communication between different spaces of the house of "bait al'sahel".
- Figure 2/47 : A sketch that shows how immediate visual inspection was controlled, both from outside and inside.
- Figure 2/48 : A sketch that shows the indirect family entrance in plan and elevation.
- Figure 2/49 : A sketch that shows the three stages of entering to the indirect family entrance.
- Figure 2/50 : A sketch showing a section passing through an exterior wall, the platform and the wall footings.
- Figure 2/51 : A photograph showing the coral blocks in a wall section.
- Figure 2/52 : A photograph showing the house walls in section, and the plaster applied on the interior.
- Figure 2/53 : A photograph showing the horizontal layers of the coral blocks and the horizontal & vertical binding mortar.
- Figure 2/54 : A photograph showing the "al'chandel" wood of a window lintel.
- Figure 2/55 : A sketch showing a section passing through a window opening.
- Figure 2/56 : A photograph showing the "al'chandel" wood trunks and "al'sherbak" in a roof of a ground floor room.
- Figure 2/57 : A photograph showing a section in a first floor slab.
- Figure 2/58 : A sketch showing a section passing through the house final roof.

- Figure 2/59 : A photograph showing the "al'chandel" wood trunks carrying the roof; "al'salhad" on an internal wall.
- Figure 2/60 : A photograph showing the staircase.
- Figure 2/61 : A photograph showing the coral columns, and the beams made of "al'chandel" wood trunks.
- Figure 2/62 : A photograph showing the windows, see the wooden shutters and the steel bars.
- Figure 2/63 : A photograph showing the steel chain lock; an internal view of the main door.
- Figure 2/64 : A photograph showing the buttresses constructed to support a cracked wall.
- Figure 2/65 : A photograph showing a part of a roof parapet.
- Figure 2/66 : A photograph showing one of the window gypsum sunbreakers.
- Figure 2/67 : A photograph showing the wind tower.
- Figure 2/68 : The range of the ratio "R" of buildings in hot & humid climates.
- Figure 2/69 : A sketch showing the effect of the roof type on the roof surface area exposed directly to the sun.
- Figure 2/70 : A sketch showing the preferred orientation of "bait al'sahel".
- Figure 2/71 : A sketch showing the effect of the orientation on the total exterior surface area of the building exposed directly to the sun.
- Figure 2/72 : A sketch showing the winter & summer floors.
- Figure 2/73 : A sketch showing the air channelling of the prevailing winds inside the courtyard and around the buildings of "bait al'sahel".
- Figure 2/74 : A sketch showing the air flow pattern of "bait al'sahel" in winter.
- Figure 2/75 : A sketch showing natural ventilation achieved using "al'barjeel" in the family rooms "al'ghoraf" of the summer floor "al'dehleez".
- Figure 2/76 : A sketch showing the air flow pattern of "bait al'sahel" in summer.
- Figure 2/77 : A sketch showing the air flow pattern in the kitchen "al'matbakh" using "al'quemry".

- Figure 2/78 : A photograph showing "al'quemry".
- Figure 2/79 : A sketch showing the effect of the wall thickness on the heat transfer from outside to inside the house.
- Figure 2/80 : A sketch showing the relation between the depth & width of the window, and the wall thickness of the house of "bait al'sahel".
- Figure 2/81 : A sketch that shows how "Biute al'Burr" are laid out together.
- Figure 2/82 : An example for "Bait al'Leban" - the mud-brick house.
- Figure 2/83 : A diagram that shows the different zones of "Bait al'Leban".
- Figure 2/84 : A diagram that shows the flow of circulation between the different zones of the house.
- Figure 2/85 : A map that shows the hierarchical spatial organisation of "Bait al'Leban".
- Figure 2/86 : A table that shows the different activities carried out in the different spaces of "Bait al'Leban", and their graphic interpretation.
- Figure 2/87 : A diagram that shows communication degrees between the house different zones.
- Figure 2/88 : A map that shows the types of communication between different spaces of "Bait al'Leban".
- Figure 2/89 : A sketch that shows a transversal section passing through "Bait al'Leban".
- Figure 2/90 : A sketch that shows the orientation of the mud-brick house.
- Figure 2/91 : A sketch that shows the natural cross ventilation of the mud-brick house.
- Figure 2/92 : A sketch that shows how type 1 of these low income houses are laid out together.
- Figure 2/93 : An example for the low income house type 1.
- Figure 2/94 : A diagram that shows the different zones of the low income house type 1.
- Figure 2/95 : A diagram that shows the main flow of circulation between the different zones of the house.
- Figure 2/96 : A map that shows the hierarchical spatial

organisation of the low income house type 1.

- Figure 2/97 : A table that shows the different activities carried out in the different spaces of the low income house type 1, and their graphic interpretation.
- Figure 2/98 : A diagram that shows communication degrees between the house different zones.
- Figure 2/99 : A map that shows the types of communication between different spaces in the house.
- Figure 2/100 : A sketch that shows the east to north-eastern orientation of the house.
- Figure 2/101 : A sketch that shows the west to south-western orientation of the house.
- Figure 2/102 : A sketch that shows how type 2 of these low income houses are laid out together.
- Figure 2/103 : A sketch that shows the low income house type 2.
- Figure 2/104 : A diagram that shows the different zones of the low income house type 2.
- Figure 2/105 : A diagram that shows the flow of circulation between the different zones of the house.
- Figure 2/106 : A map that shows the hierarchical spatial organisation of the low income house type 2.
- Figure 2/107 : A table that shows the different activities carried out in the different spaces of the low income house type 2, and their graphic interpretation.
- Figure 2/108 : A diagram that shows communication degrees between the house different zones.
- Figure 2/109 : A map that shows the types of communication between different spaces in the house.
- Figure 2/110 : A sketch that shows a transversal section passing through the low income house type 2.
- Figure 2/111 : A sketch that shows the orientation of the low income house type 2.
- Figure 2/112 : A sketch that shows the air flow pattern around the low income house type 2.
- Figure 2/113 : A table that shows the recommended low income house types and their constituents with respect to the corresponding family sizes.

Chapter Three

Neighbourhood patterns in Abu Dhabi

In this chapter examples for traditional and contemporary neighbourhoods in Abu Dhabi will be shown. A brief discription of both will be carried out respectively through the following aspects:

-Functional -Socio-cultural -Environmental

The conclusion based on this brief discription will assist in developing layout parameters for groups of houses and neighbourhoods in Abu Dhabi. This chapter will be structured as follow:

3.1 Examples for traditional neighbourhood patterns.

3.2 Examples for contemporary neighbourhood patterns.

3.3 Conclusion.

3.1 Examples for traditional neighbourhood patterns.

Due to environmental, socio-cultural and other conditions influencing the urban design in Abu Dhabi, the local people grouped their houses developing two main types of neighbourhood patterns. They reflect their social behaviour patterns, and adapt to the existing environmental conditions of Abu Dhabi. The neighbourhoods of Abu Dhabi usually consist of "Biute al'Hadhar" gathered in groups of houses locally called "al'Fereej" (see chapter two). Since "biute al'hadhar" are of two types; "biute al'sahel" and "biute al'burr", two main types of traditional neighbourhoods can be respectively recognised in Abu Dhabi. These two types are:

Al'Sahel neighbourhoods

They are neighbourhoods which consist of groups of houses built on the coast of Abu Dhabi and any of its islands, these houses are called "biute al'sahel" (see Fig 1&2).

Al'Burr neighbourhoods

They are neighbourhoods which consist of groups of houses built on the main land of Abu Dhabi, these houses are called "biute al'burr" (see Fig 3&4).

The traditional "al'sahel" neighbourhoods are built along the coast line of Abu Dhabi (see Fig 5), while traditional "al'burr" neighbourhoods are built on the edges of the palm fields (see Fig 6). Referring to "al'Muqaddasi's" theories on Arab-Islamic settlements. Al'Muqaddasi is one of the medieval arab geographers who divided the islamic greater region into sub-regions as a mean of studying its settlements. His summary was published in 985 - 986 AD, in "Ahsan al'Taqasim fi Ma'rifat al'Aqalim" which means the best classification for the knowledge of regions. Also referring to his theoretical hierarchy of settlements (see Fig 7). The traditional "al'sahel" neighbourhoods grouped together form a "Madinah" which means a market town. The plural of "madinah" is "Mudun". This is due to their economical activities, related to their geographical location being on the coast, of trading and importing and exporting goods. The traditional "al'burr"

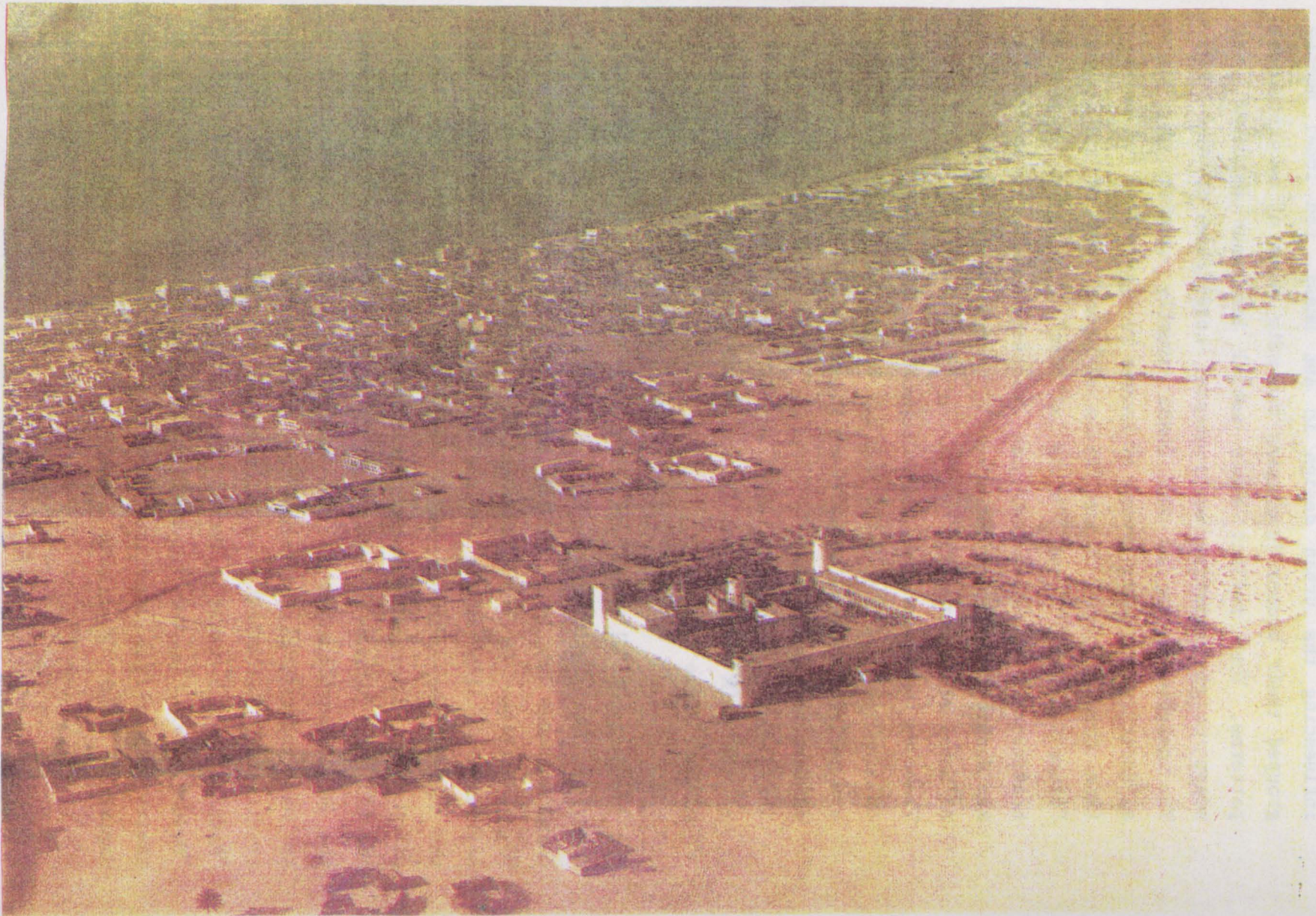

Fig 1 : A photograph that shows Abu Dhabi city and the Fortress Palace in the year 1966 (1).

neighbourhoods grouped together form a "Qaryah" which means a village. The plural of "Qaryah" is "Qura". This is due to their agricultural economic activities related to their location on the edges of the palm fields.



Fig 2 : A photograph that shows one of the traditional neighbourhoods located on the Abu Dhabi coast in the year 1966 (2).

Fig 3 : A photograph that shows one of the villages in Al'Ain oases (3).

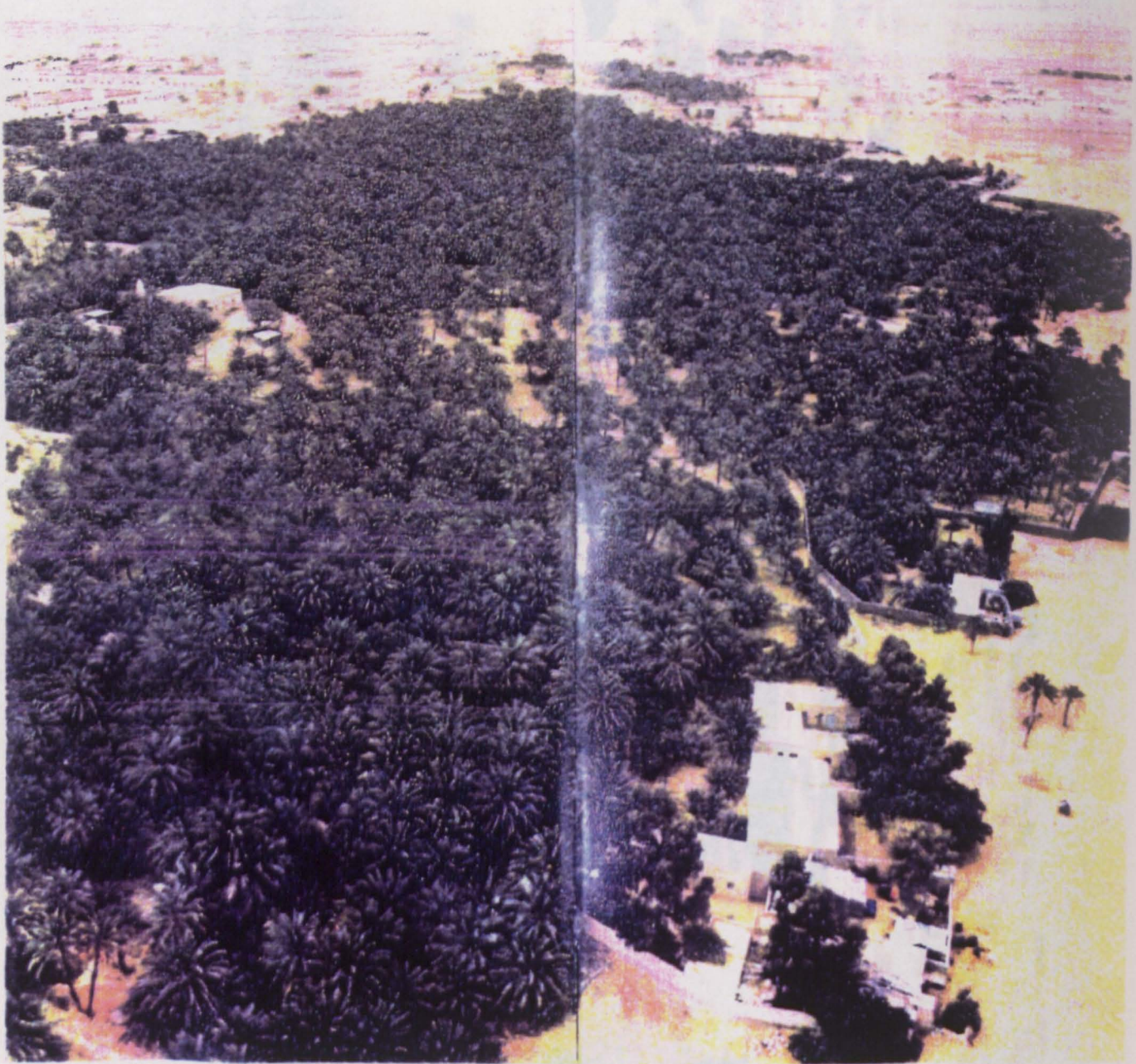
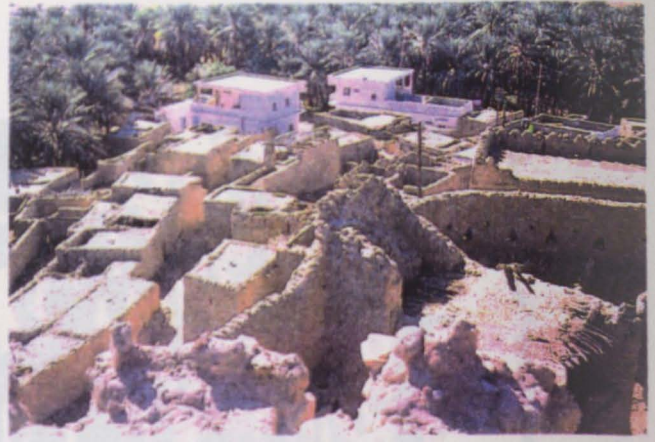

Fig 4 : A photograph that shows houses built on the edges of the palm fields in Al'Ain oases (2).

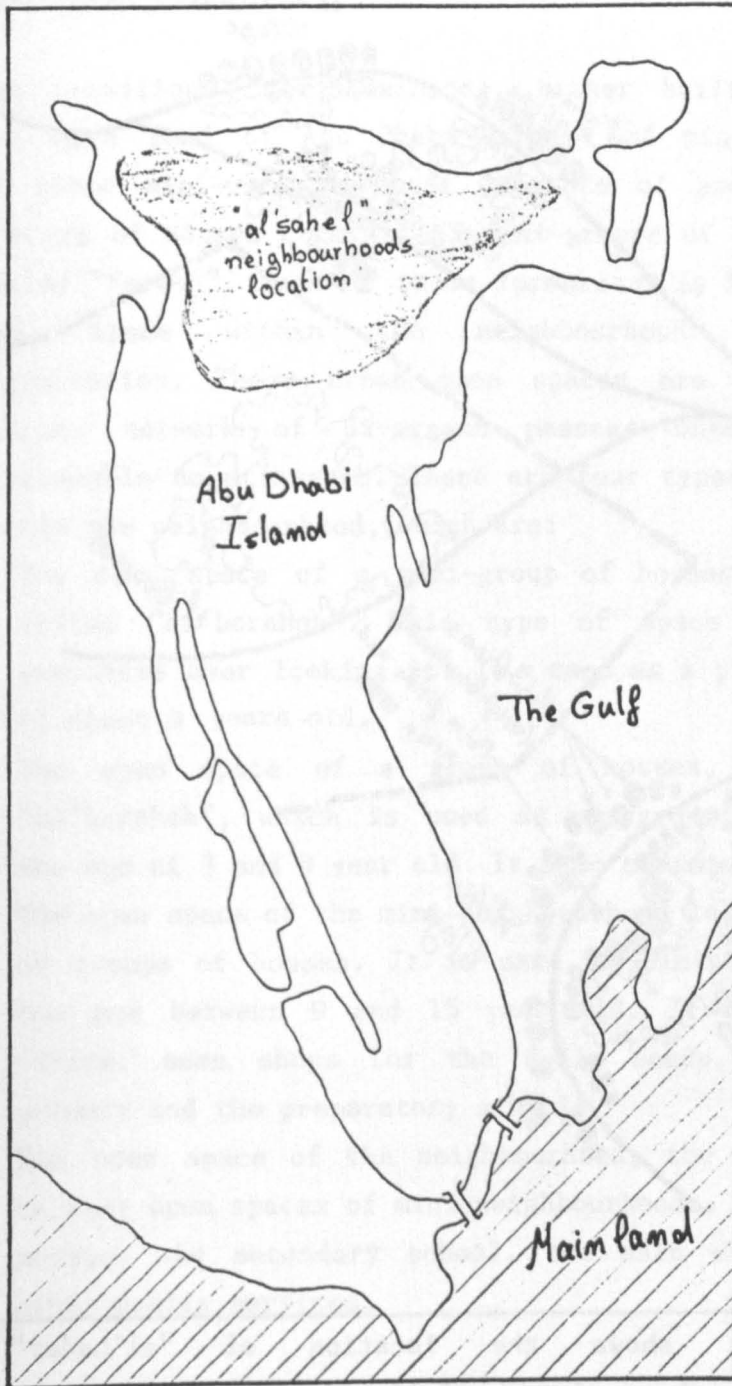

Fig 5 : map that shows the location of "al'sahel" neighbourhoods on the Abu Dhabi island (5).

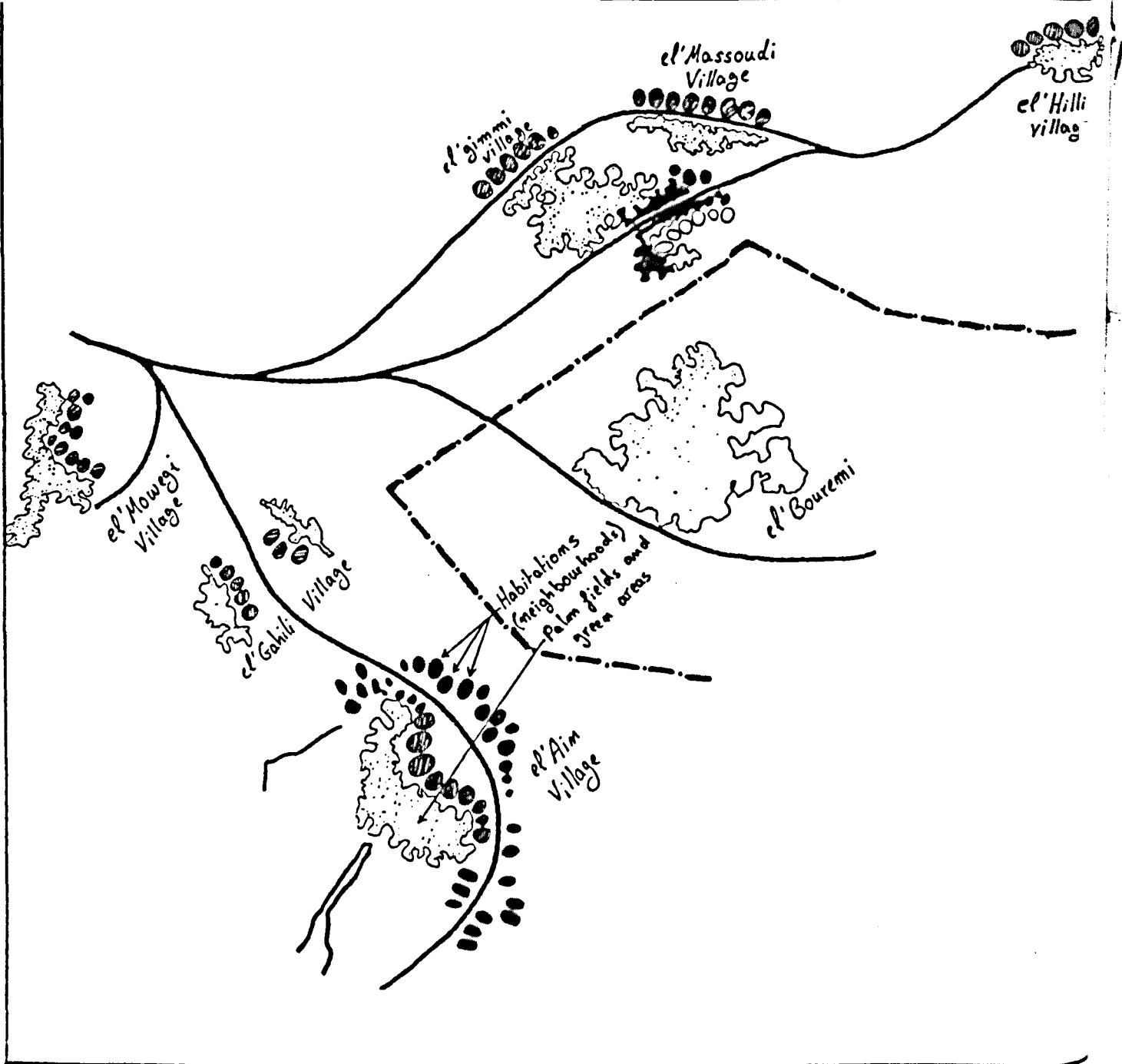

Fig 6 : map that shows the location of "al'hadar" neighbourhoods on the Abu Dhabi main land (6).

A. THEORETICAL HIERARCHY OF SETTLEMENTS:

1. AMSAR (SING MISR), METROPOLIS
2. OASABAT (SING OASABAH), FORTIFIED PROVINCIAL CAPITALS
3. MUDUN (SING MADINAH), PROVINCIAL TOWNS, A MAIN TOWN OF A DISTRICT, OR A MARKET TOWN
4. OURA (SING. OARYAH), VILLAGES

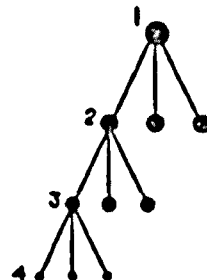

Fig 7 : diagramme that shows "Al'Muqaddasi's" grading of settlements (5)

Functional Aspect

The traditional neighbourhoods, either built on the coast or on the main land of Abu Dhabi consist of mini-neighbourhoods. Each of these mini-neighbourhoods consists of groups of houses, where a group of houses consists of mini-groups of houses each is locally called "Fereej". Each of these formations is located around an urban open space within the neighbourhood hierarchical spatial organisation. These urban open spaces are linked together by a complex network of divergent passage ways and streets highly impermeable to strangers. There are four types of urban open spaces within the neighbourhood, which are:

1. The open space of a mini-group of houses "al'fereej" which is called "al'barahah". This type of space leads to the houses entrances over looking it. It's used as a playground for children of about 3 years old.
2. The open space of a group of houses, which leads to many "al'barahah", which is used as playground for children between the age of 3 and 9 year old. It also contains the kindergarden.
3. The open space of the mini-neighbourhood leads to many open spaces of groups of houses. It is used as playgrounds for children of the age between 9 and 15 year old. It also contains a post office, some shops for the daily needs, a small mosque, the primary and the preparatory schools.
4. The open space of the neighbourhood, the central piazza, leads to many open spaces of mini-neighbourhoods. It contains the friday mosque, the secondary school, the main shopping centre and all other public services.

Conclusion

The traditional neighbourhoods of Abu Dhabi consist of various open urban spaces of different sizes and functions laid out together in hierarchical spatial organisation (see Fig 8). Their patterns prevent immediate physical intrusion of strangers through their structure.

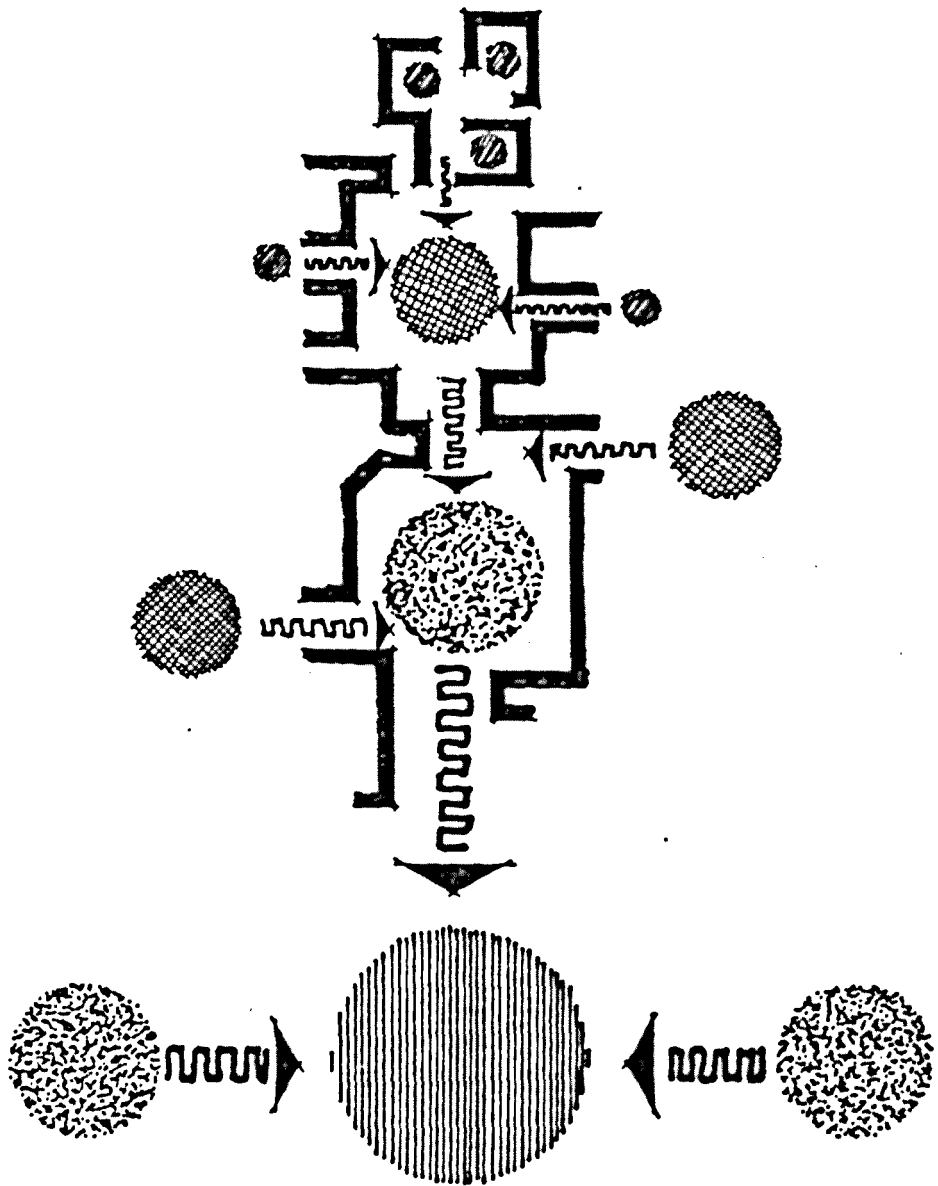





Fig 8 : diagramme that shows the hierarchical, sequential spatial organisation of urban spaces in the neighbourhood (7).

Key:

-  mini-group of houses open urban space.
-  open space for group of houses.
-  open space for mini-neighborhoods.
-  open space for the neighbourhood.

Socio-cultural Aspect

The design of the social urban spaces within the traditional neighbourhoods is a direct interpretation of the social behaviour patterns of the local people. Since privacy is a very important social value induced by the socio-cultural background of the local people, communication between different social urban spaces of the neighbourhood is governed by the degree of privacy each space requires. This resulted in a hierarchical spatial organisation of spaces, starting from the public space—the main street to the most private space—the house (see Fig 9). The complexity of the divergent passage ways within the neighbourhood resulted in a highly impermeable visual layout.

Conclusion

The traditional neighbourhood patterns of Abu Dhabi achieve the privacy of each type of social urban space within their structures. It also protects these social urban spaces of different privacy degrees from immediate visual intrusion by strangers.

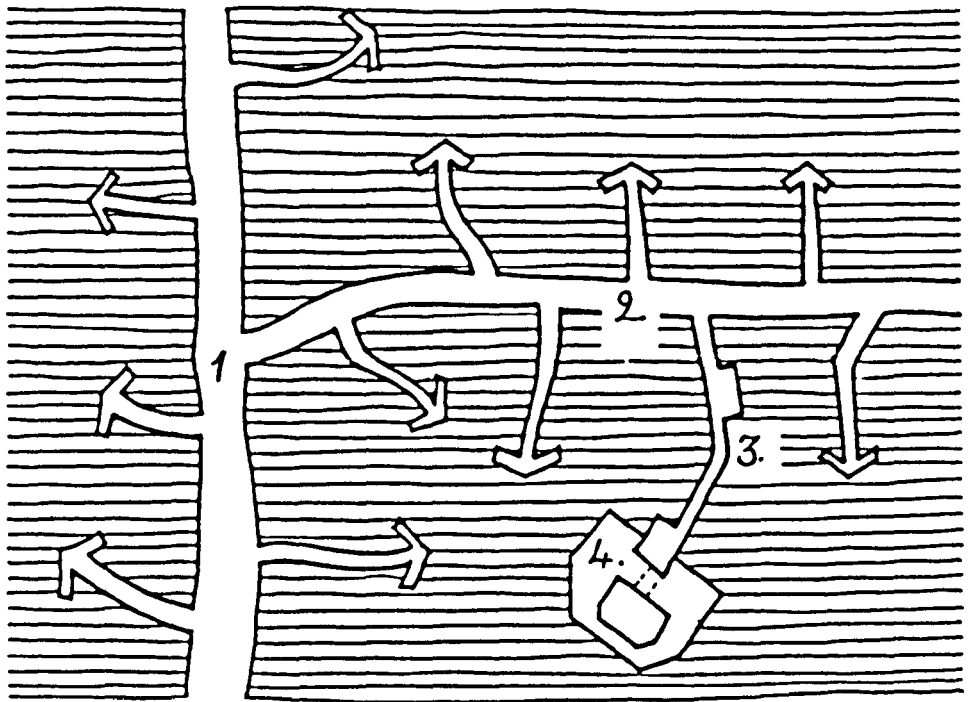

Fig 9 : diagramme that shows various degrees of streets privacy within the neighbourhood (8).

Key:

- | | |
|------------------------|----------------|
| 1. = Main street. | - Public |
| 2. = Secondary street. | - Semi-public |
| 3. = Drive way. | - Semi-private |
| 4. = A house | - Private |

Environmental Aspect

The traditional neighbourhood patterns of Abu Dhabi did not only achieve functional and socio-cultural requirements, but also minimised the discomfort of the local climate. The following elements helped the successful adaptation to the severe local environmental conditions. These elements are:

- The shape and orientation of streets
- Sun protection
- Natural ventilation

The shape and orientation of streets

The streets of different functional and social degrees were of irregular linear shapes. The orientation being north to north-west allows the streets and urban spaces to be shaded almost all through the day (see Fig 10).

Sun protection

Sun protection was achieved by planting palm trees to provide shade and to soften the climatic effect on the outdoor open urban spaces. The ratio of the street width to the height of the surrounding houses boundary walls is about 60 - 70 %, and for the urban spaces the ratio of the space width to the height of the spatial enclosure is about 1.5 - 3.00 (see Fig 11).

Natural ventilation

The streets being of irregular linear shapes and of widths that vary from 2.00 - 2.50 metres, facing the prevailing winds direction helped air channelling within the urban spaces linked by them. Thus preventing the accumulation of hot and/or hot humid air in these urban spaces (see Fig 12).

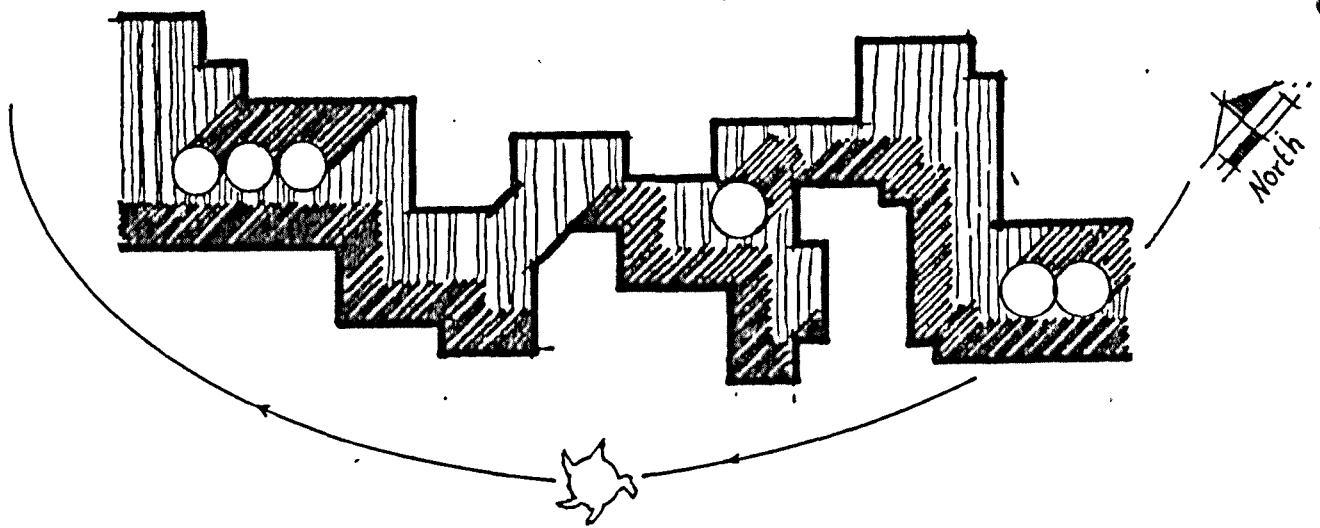

Fig 10 : sketch that shows the correct orientation of streets

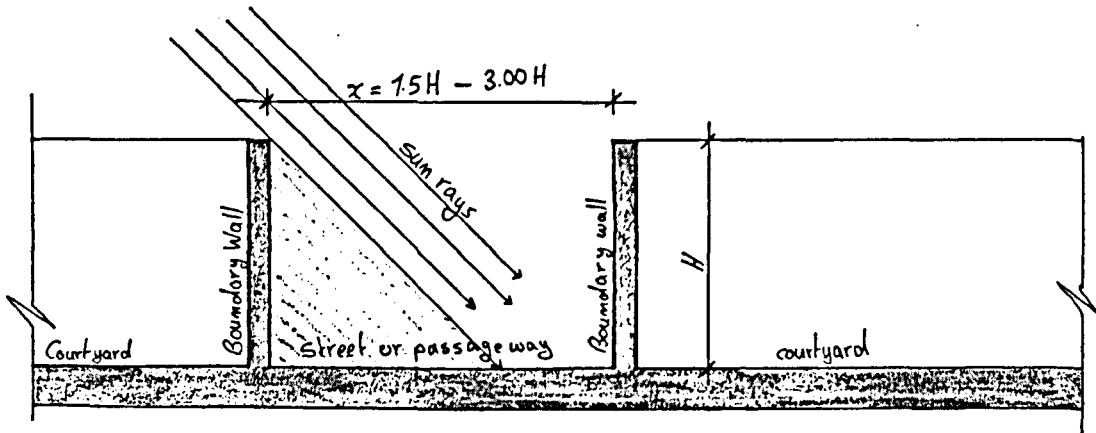

Fig 11 : sketch that shows the ratio of the street width to the height of the surrounding houses boundary walls

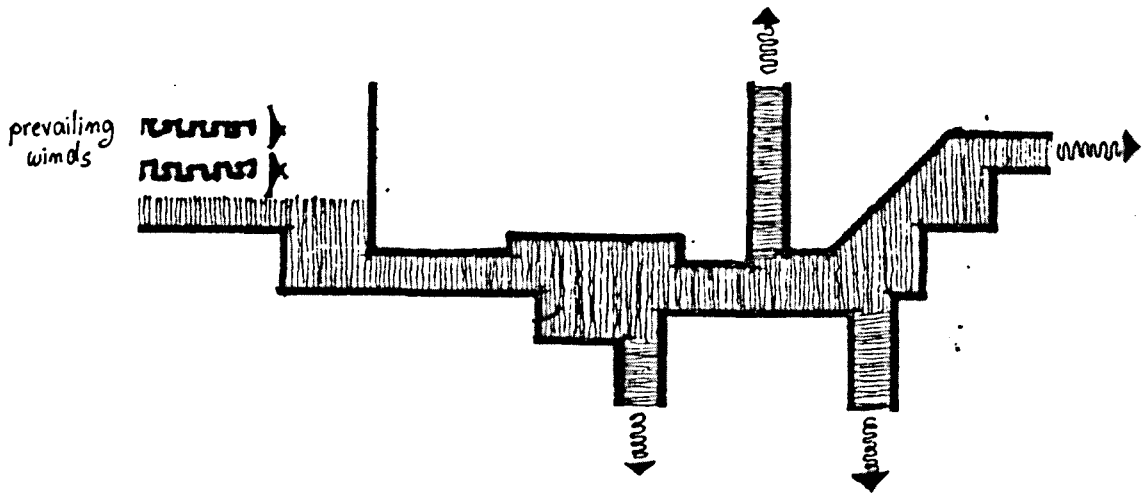

Fig 12 : sketch that shows air channelling within urban spaces

Conclusion

The traditional neighbourhood patterns provide comfortable living conditions. Taking into consideration maintaining natural ventilation, providing sun protection and streets proper orientation, were the elements that allowed the traditional neighbourhoods to adapt to the local climatical conditions of their surrounding enviroment.

3.2 Examples for contemporary neighbourhood patterns

In fulfilment to the ambitious housing policy developed by the government of Abu Dhabi. A number of foreign urban designers and town planners were involved in the development of the contemporary neighbourhood patterns. A brief discription of these patterns will be carried out. Figures 13, 14 and 15 show examples for the contemporary neighbourhoods in Abu Dhabi. Most of these neighbourhoods consist of one size low income house type. This house type is monotonously repeated in single or back-to-back house rows surrounded by straight linear streets (see also Fig 92 in chapter two).

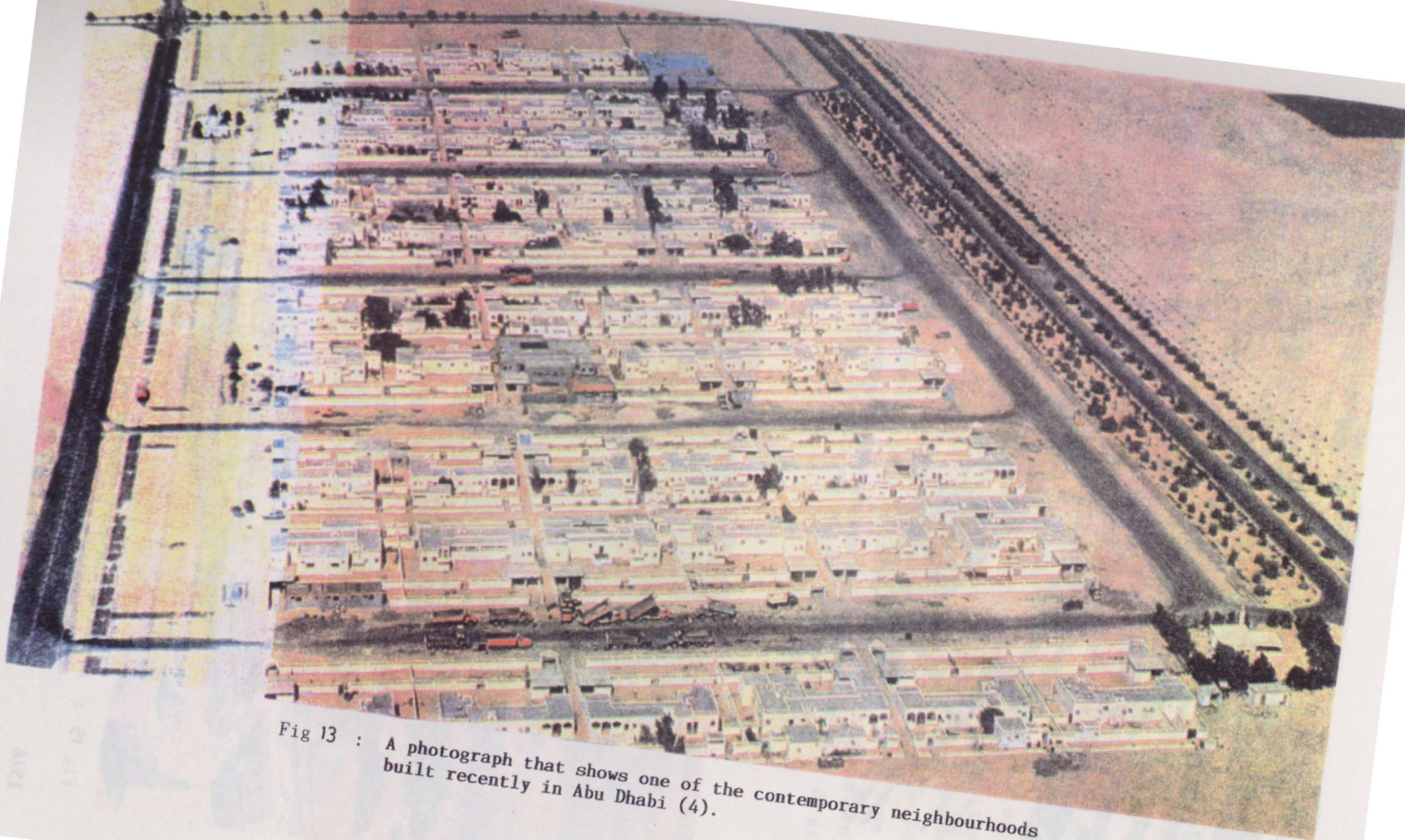

Fig 13 : A photograph that shows one of the contemporary neighbourhoods built recently in Abu Dhabi (4).



Fig 14 : A photograph that shows a part of one of the contemporary neighbourhoods in the new city of "Dalma" in the emirate of Abu Dhabi (1).

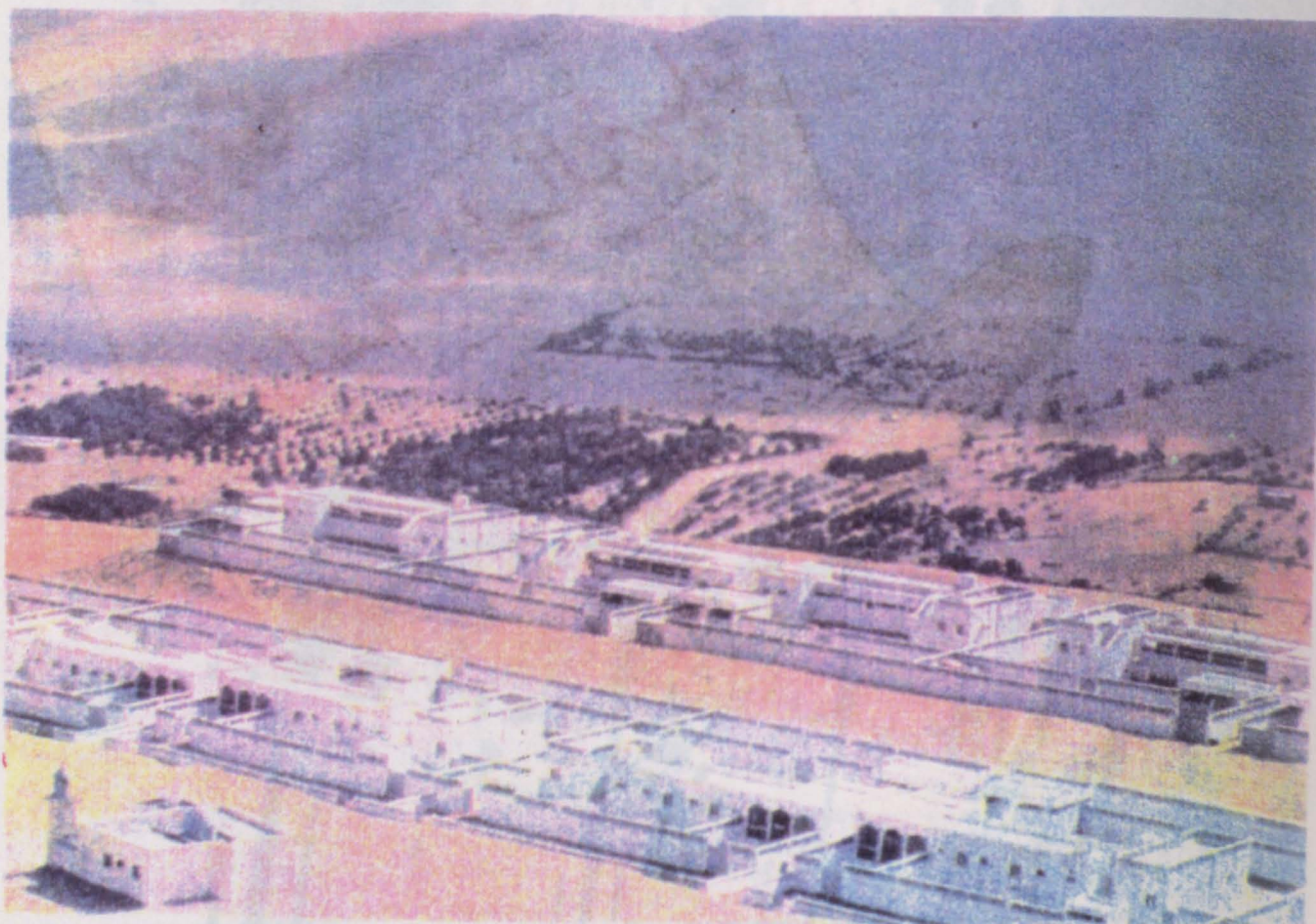

Fig 15 : A photograph that shows a part of one of the contemporary neighbourhoods in the western area of the emirate of Abu Dhabi (4).

Functional Aspect

The contemporary neighbourhood patterns consist of housing clusters of low income house types surrounded by dual carriage ways from the four directions. These dual carriage ways being of straight and linear shapes allow immediate physical intrusion of strangers through the neighbourhood structure. The hierarchical spatial organisation of open urban spaces within the neighbourhood is absent. There are no transitional urban spaces between the house indoor private space and the main urban space of the neighbourhood. The lack of public services except for the mosque. Apart from small shops that can exist in the neighbourhood with private efforts, kindergardens, schools, shops and other governmental public services can be located in neighbouring bigger villages several kilometres away from most newly built contemporary neighbourhoods. The later are often not within a reasonable walking distances.

Conclusion

The absence of hierarchical, sequential and spatial organisation of urban spaces within the contemporary neighbourhood patterns. These patterns allow immediate physical intrusion of strangers through their structures.

Socio-cultural Aspect

The contemporary neighbourhood patterns do not correspond to the social behaviour patterns of the local people, where the social value of privacy is ignored. Communication between groups of houses and main streets does not achieve the degree of privacy they require. Groups of houses being directly surrounded by main wide streets of straight and linear shapes allow visual impermeability of strangers. The contemporary neighbourhood patterns do not achieve the required hierarchical, sequential and spatial organisation of social urban spaces.

Conclusion

The contemporary neighbourhood patterns do not achieve the required hierarchical spatial organisation necessary to achieve a sequential organisation of transitional social urban spaces of different privacy degrees.

Environmental Aspect

Regarding the severe environmental conditions of Abu Dhabi, the contemporary neighbourhood patterns do not adapt efficiently to the local environment. This is due to the negligence of the following:

- The shape and orientation of streets
- Sun protection
- Natural ventilation

The shape and orientation of streets

The streets being of straight and linear shapes parallel to the groups of houses which they surround, do not achieve the required orientation for all of them. Where if the houses front elevations are facing the prevailing winds, streets parallel to them will be oriented east-west and so on. Therefore these space areas are exposed to the sun all through the day and do not provide shaded areas.

Sun protection

Sun protection is completely ignored within the contemporary neighbourhood patterns where streets widths ratio to the height of the surrounding houses boundary walls is about 11 to 1. Therefore streets are exposed to the sun all through the day (see Fig 16). The absence of plantation in remoted neighbourhoods that can provide shaded areas aggravates the lack of shaded areas. On the other hand the streets widths increased the ground surface area between houses exposed to direct sun rays, thus increased the amount of reinduced heat at night which kept high ambient temperature degrees within the neighbourhoods.

Natural ventilation

The streets being of regular linear shapes, very wide and rarely of proper orientation do not help air channelling around the houses. Thus allowing the accumulation of hot and/or humid air around the houses, which prevent rapid cooling of the houses and ground surfaces.

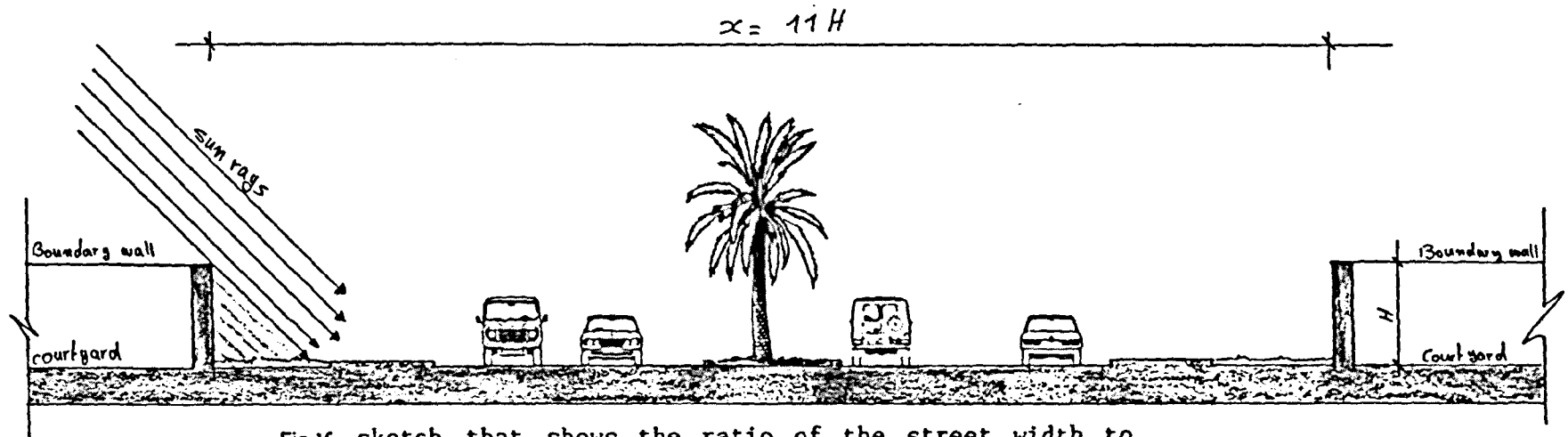

Fig 16 sketch that shows the ratio of the street width to the height of the surrounding houses boundary walls

Conclusion

The contemporary neighbourhood patterns do not provide comfortable living conditions. The natural ventilation, sun protection and proper orientation of streets are totally ignored. Therefore, the contemporary neighbourhoods do not adapt to the local climatical conditions of their surrounding environment.

3.3 Conclusion

Comparing both descriptions of the traditional and the contemporary neighbourhood patterns in Abu Dhabi, explains the reasons why the contemporary neighbourhoods have not been successful in offering the local people a convenient urban environment. The lack of knowledge on the socio-cultural background of the local people, and their social behaviour patterns. The influence of the various foreign cultural backgrounds of the urban designers and town planners involved in preparing the neighbourhood urban schemes in particular and the towns master plans in general. In addition to this is the negligence of the local environmental conditions depending on modern urban design and planning theorys, that might be successful in their countries of origin which is not the case in Abu Dhabi. This resulted in the following :

Due to the severe environmental conditions, and the local people living in air conditioned multi-enclosures moving from one to the other through the day. From the house to the car, then to work and then back home. The need of intensive road construction so that the car can reach everywhere, and the lack of full segregation between drive ways and walk ways. Both led to the complete disappearance of the main pedestrian areas and walk way networks.

The urban design in Abu Dhabi depends on the method of Sub-division plan and not on the Free plan. This resulted into plots of land equal in size and laid out in parallel on both sides of the streets. Therefore forming separated spaces between the houses boundary walls, normally of 3.00 to 6.00 metres wide. These spaces not being integrated within a comprehensive pedestrian network are used by the local people as extra parking places, or for installing extra water tanks or even sometimes for gathering garbage bags, etc. ...

The absence of the human scale in proportions and dimensions

of the neighbourhood design. Where the ratio of the streets width to their enclosure heights are completely out of scale.

The lack of social urban spaces within the neighbourhood patterns and the disintegration of the green areas separately grouped in the form of public gardens, or on the separating islands between both directions of the streets.

Taking into consideration the traditional values of the neighbourhood patterns in Abu Dhabi, will help developing layout parameters for more convenient contemporary groups of houses and neighbourhood patterns, which will be carried out in chapter four. A proposed design solution for mini-neighbourhoods in Abu Dhabi is shown in chapter five in figure 54 on page 209B.

List of Quotations

- (1) Al'Ettihad, "18 Years of Cooperation, the leadership and the people", a special supplement on the 18th National Day, Abu Dhabi, December 1989, pp 27, 127 (Title translated by the author).
- (2) Tammam, H., "The Leader and the March", Abu Dhabi, 1981, pp 63, 84
- (3) Kay, S. & Zandi, D., "Architectural Heritage Of The Gulf", Dubai, 1991, p 51
- (4) Al'Ettihad, "The glorious years of prosperity", a special supplement on the occasion of the Accession Day, Abu Dhabi, August 1991, pp 112, 114, 115 (Title translated by the author).
- (5) Howeedy, M. A., "A Study Suggesting Contemporary Urban Design Guidelines Using The United Arab Emirates As An Illustrative Case", Masters thesis, Michigan, 1989, pp 40, 72 (not published)
- (6) Reproduction by the author from: Ibrahim, M. A., "The Gulf Architecture Between Originality And Renovation", Part Two, Cairo, 1972, p 90 (Title translated by the author).
- (7) Reèproduction by the author from: Afifi, A. K., and Sarhan, A. E., "The effect of climatic factors on Urban Design in the U.A.E.", a research paper presented at the U.A.E. University, Al'Ain, 1985, p 28 (Title translated by the author-not published)
- (8) Reproduction by the author from: Salmani, T. M. A., "Privacy In Housing - Perception And Applications In Islamic Architecture", a research paper, Abu Dhabi, 1989, pp 16 - 18 (Not published)

List of Figures

- Figure 3/1 : A photograph that shows Abu Dhabi city and the Fortress Palace in the year 1966
- Figure 3/2 : A photograph that shows one of the traditional neighbourhoods located on the Abu Dhabi coast in the year 1966
- Figure 3/3 : A photograph that shows one of the villages in Al'Ain oases
- Figure 3/4 : A photograph that shows houses built on the edges of the palm fields in Al'Ain oases
- Figure 3/5 : A map that shows the location of "al'sahel" neighbourhoods on the Abu Dhabi island
- Figure 3/6 : A map that shows the location of "al'hadar" neighbourhoods on the Abu Dhabi main land
- Figure 3/7 : A diagraph that shows "Al'Muqaddasi's" grading of settlements
- Figure 3/8 : A diagraph that shows the hierarchical, sequential spatial organisation of urban spaces in the neighbourhood
- Figure 3/9 : A diagraph that shows various degrees of streets privacy within the neighbourhood
- Figure 3/10 : A sketch that shows the correct orientation of streets
- Figure 3/11 : A sketch that shows the ratio of the street width to the height of the surrounding houses boundary walls
- Figure 3/12 : A sketch that shows air channelling within urban spaces
- Figure 3/13 : A photograph that shows one of the contemporary neighbourhoods built recently in Abu Dhabi
- Figure 3/14 : A photograph that shows a part of one of the contemporary neighbourhoods in the new city of "Dalma" in the emirate of Abu Dhabi
- Figure 3/15 : A photograph that shows a part of one of the contemporary neighbourhoods in the western area of the emirate of Abu Dhabi

Figure 3/16 : A sketch that shows the ratio of the street width to the height of the surrounding houses boundary walls

Chapter Four

Establishing the criteria of housing design in Abu Dhabi

In this chapter the criteria of housing design in Abu Dhabi will be established. Taking into consideration the results of the analytical study carried out in chapter two, along with the post-occupancy housing survey carried out by the Planning Department of Abu Dhabi. Dwelling unit standards and layout parameters for groups of houses will be developed. This chapter is structured as follow:

- 4.1 Developing dwelling unit standards.
- 4.2 Developing layout parameters for groups of houses.

4.1 Developing dwelling unit standards

The housing design in Abu Dhabi should conform with the following dwelling unit standards, which are developed in accordance to the conclusion of the analytical study carried out in chapter two. These standards are set to maintain required functional performance of the dwelling unit, comply with the social behaviour patterns of the local people, integrate the locally available construction materials & methods, and provide the local people with comfortable environmental living conditions.

These standards are :

- 4.1.1 The dwelling unit standard sizes.
- 4.1.2 The dwelling unit main zones.
- 4.1.3 The dwelling unit courtyard.
- 4.1.4 The dwelling unit entrances.
- 4.1.5 The dwelling unit spaces.
- 4.1.6 Privacy.
- 4.1.7 Design standards regarding climatical conditions.
- 4.1.8 Technical standards.

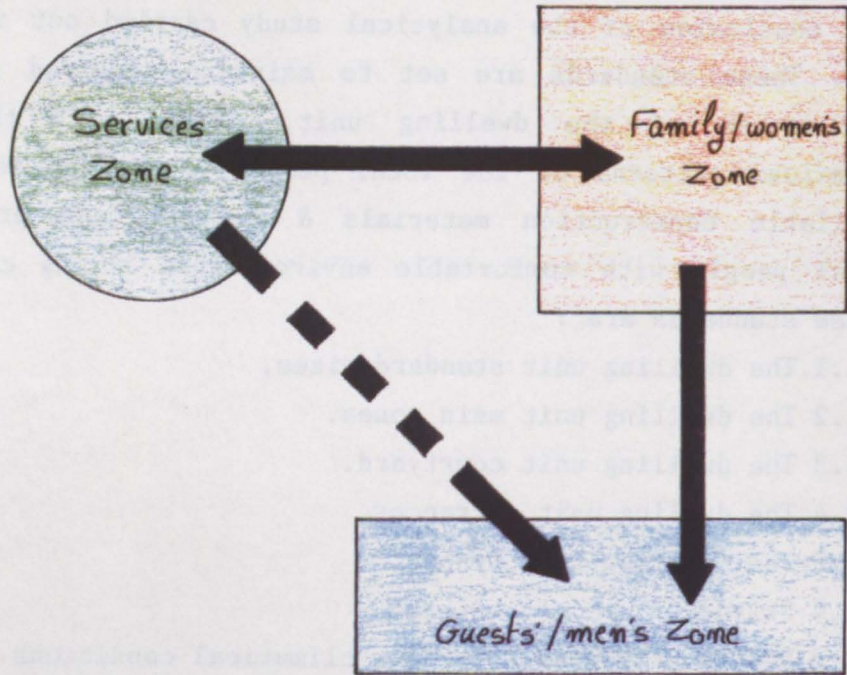





Fig 1 : A diagram that shows the recommended communication degrees between the house different zones.

Key :

-  mutual and dense
-  single and frequent
-  single and infrequent

4.1.1 The dwelling unit standard sizes

With respect to the different family sizes of the local people living in Abu Dhabi (see Socio-cultural conditions), four dwelling unit standard sizes should be available. These four sizes are :

- "A" : One bedroom dwelling unit (for families of 1-3 persons)
- "B" : Two bedroom dwelling unit (for families of 4-6 persons)
- "C" : Three bedroom dwelling unit (for families of 7-9 persons)
- "D" : Four bedroom dwelling unit (for families of 10 or more)

4.1.2 The dwelling unit main zones

A dwelling unit should be divided into three main zones : Family / women's zone; Guests / men's zone; Services zone.

These three zones should be separated in order to achieve absolute privacy for each zone, guarantee an uninterrupted flow of circulation between them which maintains the required functional performance of each zone.

The location of each of the three zones with respect to the others, should be governed by the communication degree between each zone and the other two (see Fig 1).

4.1.3 The dwelling unit courtyard

The dwelling unit three zones should be laid out around a private courtyard ; it is used for family gatherings, celebrations, gardenning and as a children playground.

The courtyard being a multi-functional outdoor private space, also serves as a transitional circulation distributing area between the house different zones.

Courtyards in dwelling units designd for hot/dry areas should be enclosed. They should maintain a skimming air flow regime.

This can be achieved by obtaining the following ratio:

courtyard longer side / surrounding building hight = 1.0 - 1.5 . This type of courtyard is an excellent thermal

regulator, where its high surrounding walls cut off the sun. It also provide shade for inner surface areas, and for the courtyard floor area during the day. It retains a pool of

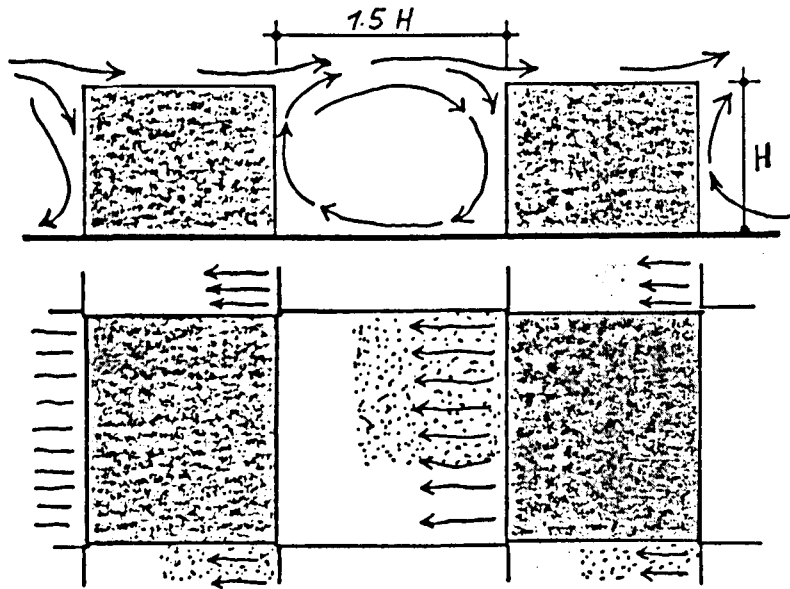

Fig 2 : A sketch that shows the skimming air flow regime.

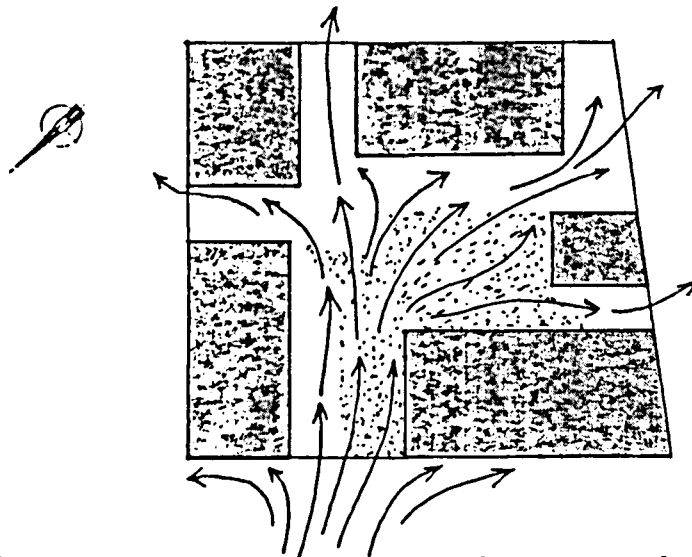

Fig 3 : A sketch that shows the semi-enclosed courtyard and maintaining air channeling around the dwelling unit buildings.

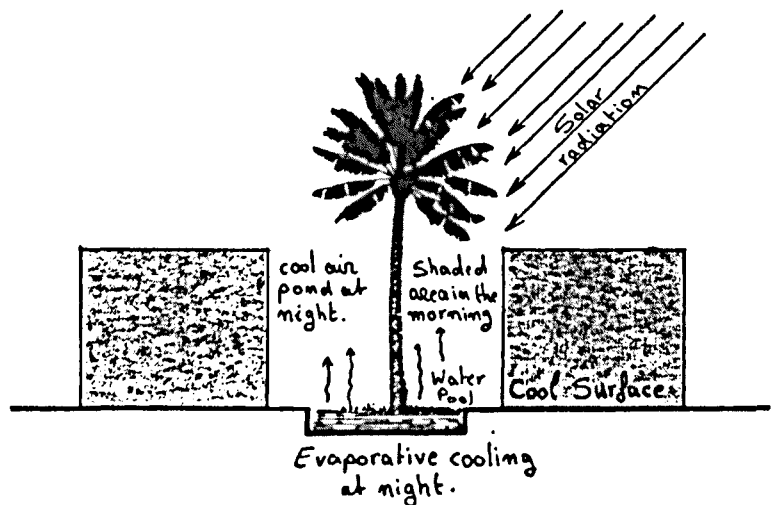

Fig 4 : A sketch that shows integrating trees, and water pools within the courtyard design.

cool air (see Fig 2).

Courtyards in dwelling units designed for hot/humid areas should be semi-enclosed. Therefore maintaining air channelling around the dwelling unit buildings, and provide plenty of outdoor shaded areas (see Fig 3).

The courtyard design should integrate the use of trees, plants and water pools (especially in hot/dry areas). This helps cooling the air by evaporation, help keeping dust down and provide more shaded areas (see Fig 4).

The courtyard allow the family / women's zone and the services zone to overlook an out door private space, while the guests / men's zone should overlook the out door public area.

4.1.4 The dwelling unit entrances

The dwelling unit should be provided with two entrances which are : Family / women's entrance; Guests / men's entrance(see Fig 5).

The family / women's entrance should allow the family members (females and/or males) to have access from outside the house to the family / women's zone and the services zone, and vice-a-verse, without passing through the guests / men's zone (see Fig 5).

The family / women's entrance should allow indirect access for the male members of the family and the family servants, from inside the house to the guests / men's zone (see Fig 5).

The family / women's entrance should be indirect (see Fig 2/18, 19). It should be provided with a large double door that allows the entry of furniture and other large house appliances. One of the door leaves should have an inset small openable shutter for entering the house. Its threshold should be of about 20 cm. higher than the entrance level, and its top lower than the average eye level by 10-15 cm. (see Fig 6).

The guests / men's entrance should allow direct access from the outdoor public space to the guests / men's zone without

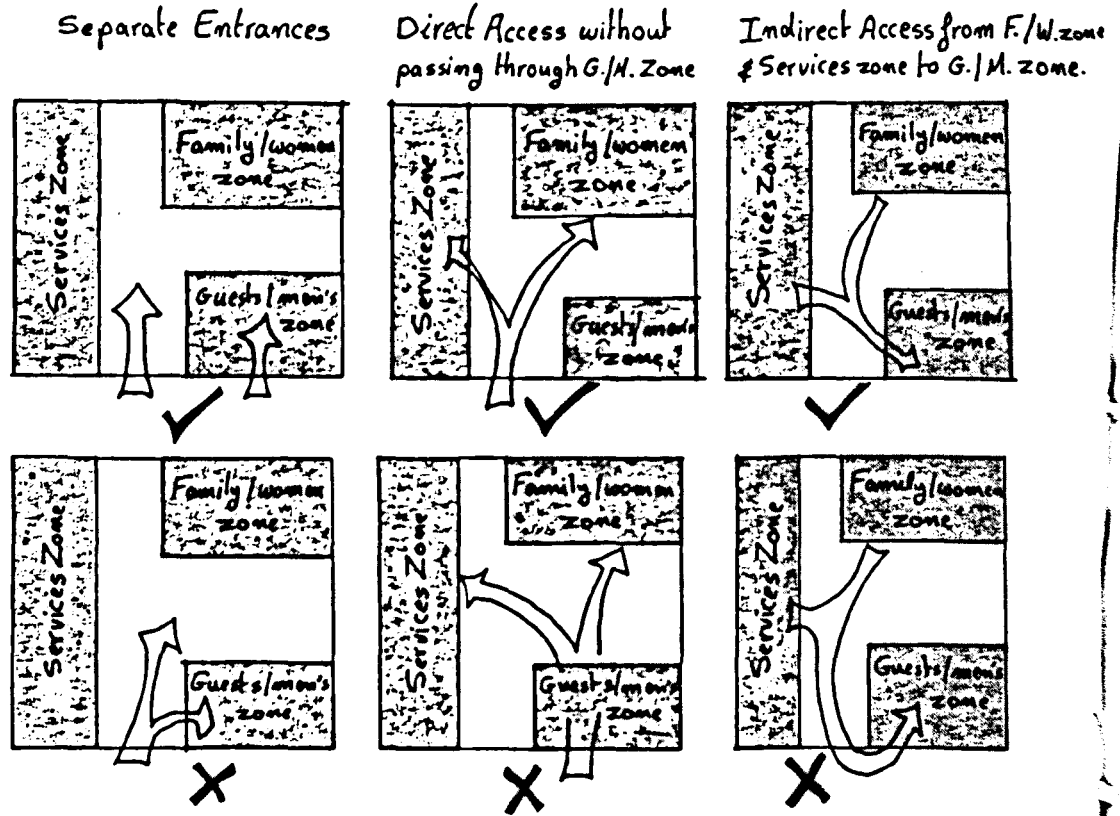

Fig 5 : Different sketches that show dwelling unit direct and indirect entrances and accesses.

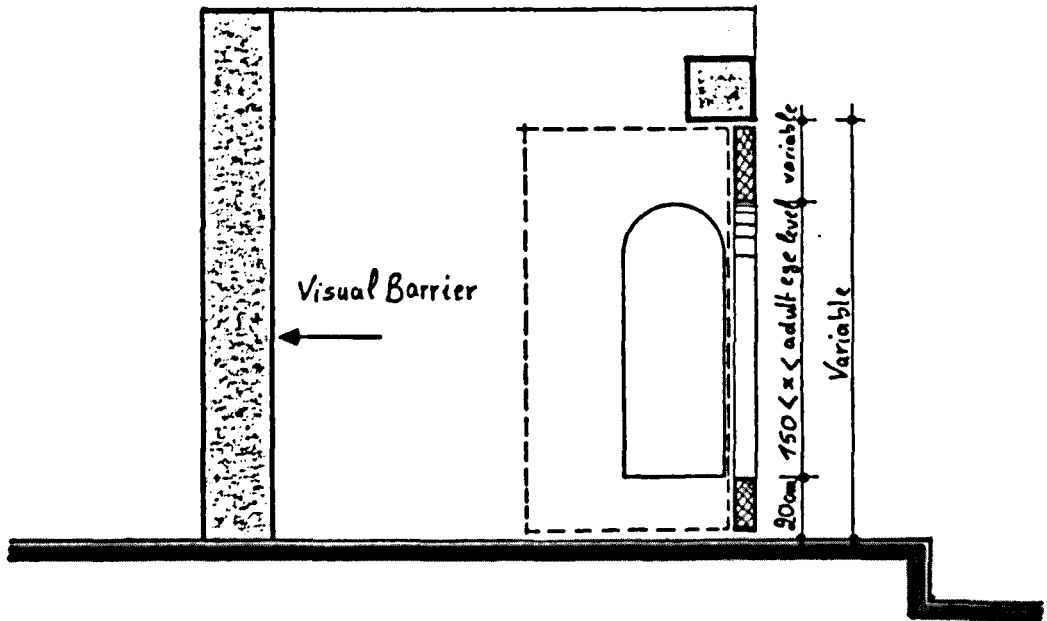

Fig 6 : A sketch that shows the indirect family/women's entrance.

passing neither through the family / women's zone, nor the services zone.

The guests / men's entrance should be of a double door, where, being open can allow one person to enter at a time (see Fig 7).

4.1.5 The dwelling unit spaces

The dwelling unit different spaces should be grouped under their correspondent zones, as follow:

Family / women's zone

Family rooms (sleeping, sitting and dining).

Dressing rooms (changing area, and clothes store).

Bathrooms (bathing, ablution and w.c.).

Family living room (family sitting, dining and female guests reception)

Guests / men's zone

Guests reception "Majlis" (male guests reception : sitting, and dining).

Appendants (showers, w.cs., and hand washing areas).

Services zone

Kitchen (cooking, and food preparation).

Store.

Servant's room (sleeping, sitting, and dining).

Servant's bathroom (bathing, ablution, and w.c.).

Car garage

Animals shelter when needed.

Most of these spaces, if not all, should be multi-functional in which different activities should be allowed to take place at different times of the day (see Figs 7 to 12).

Each of these spaces should be of a sufficient surface area, and the number of each space type in the four different dwelling unit sizes (A, B, C and D) should correspond to the family size which will occupy the dwelling unit. Figure 14 shows four different space programmes (recommended by the author) with respect to the four different family sizes.

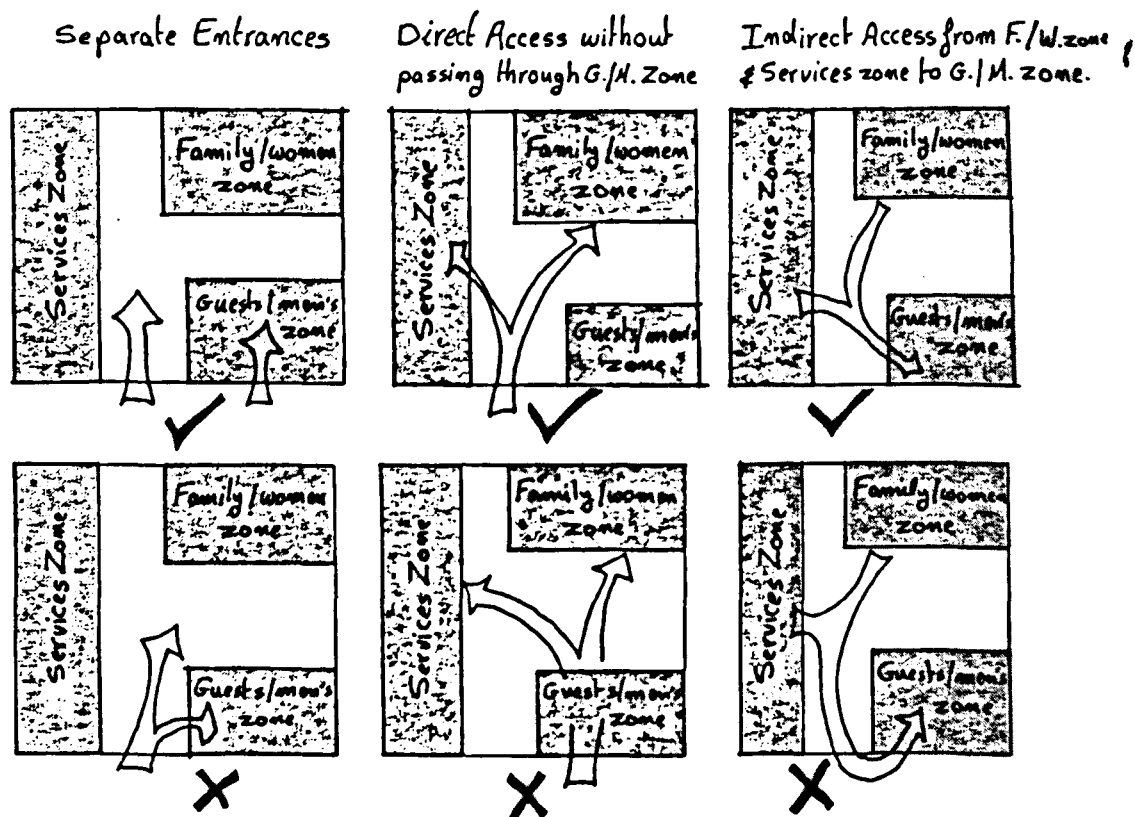

Fig 5 : Different sketches that show dwelling unit direct and indirect entrances and accesses.

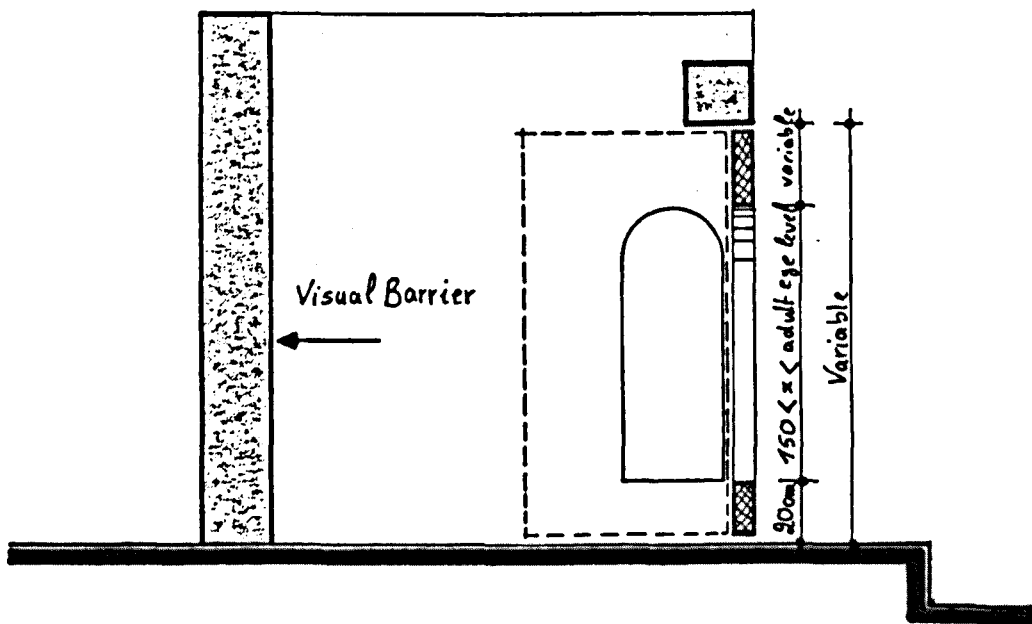

Fig 6 : A sketch that shows the indirect family/women's entrance.

passing neither through the family / women's zone, nor the services zone.

The guests / men's entrance should be of a double door, where, being open can allow one person to enter at a time (see Fig 7).

4.1.5 The dwelling unit spaces

The dwelling unit different spaces should be grouped under their correspondent zones, as follow:

Family / women's zone

Family rooms (sleeping, sitting and dinning).

Dressing rooms (changing area, and clothes store).

Bathrooms (bathing, ablution and w.c.).

Family living room (family sitting, dinning and female guests reception)

Guests / men's zone

Guests reception "Majlis" (male guests reception : sitting, and dinning).

Appendants (showers, w.c.s., and hand washing areas).

Services zone

Kitchen (cooking, and food preparation).

Store.

Servant's room (sleeping, sitting, and dinning).

Servant's bathroom (bathing, ablution, and w.c.).

Car garage

Animals shelter when needed.

Most of these spaces, if not all, should be multi-functional in which different activities should be allowed to take place at different times of the day (see Figs 7 to 12).

Each of these spaces should be of a sufficient surface area, and the number of each space type in the four different dwelling unit sizes (A, B, C and D) should correspond to the family size which will occupy the dwelling unit. Figure 14 shows four different space programmes (recomended by the author) with respect to the four different family sizes.

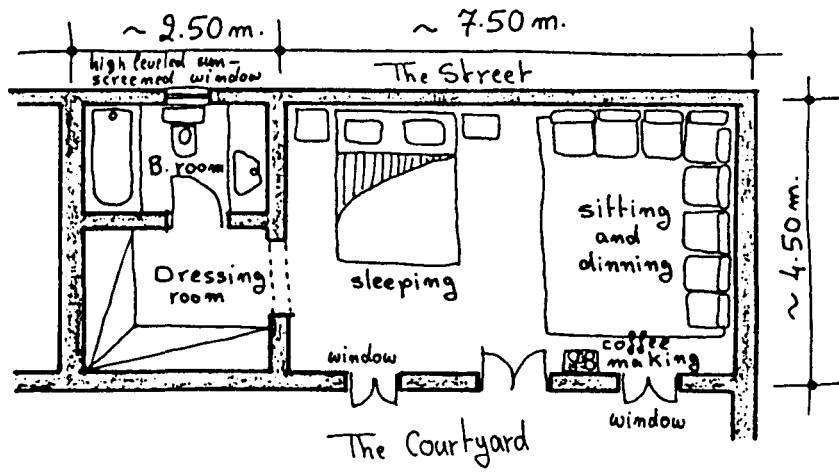

Fig 7 : A sketch that shows family bedroom, dressing room, and bathroom.

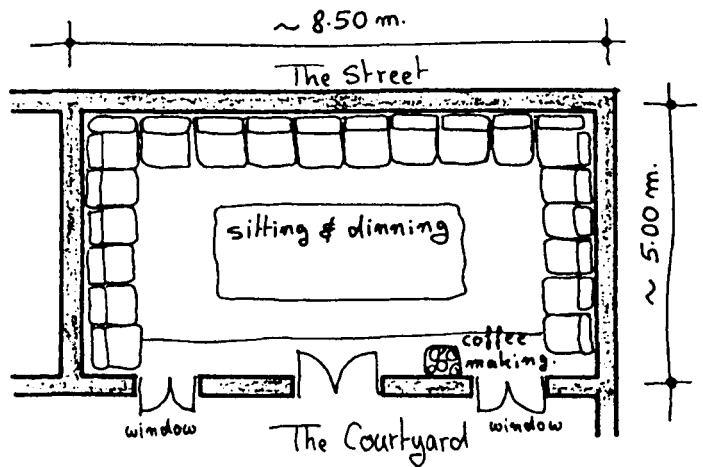

Fig 8 : A sketch that shows family living room.

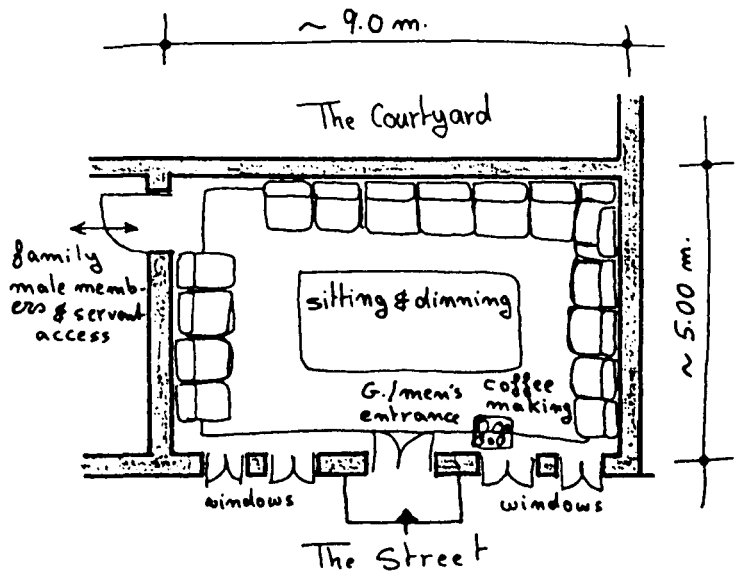

Fig 9 : A sketch that shows guests/men's reception "al'Majlis".

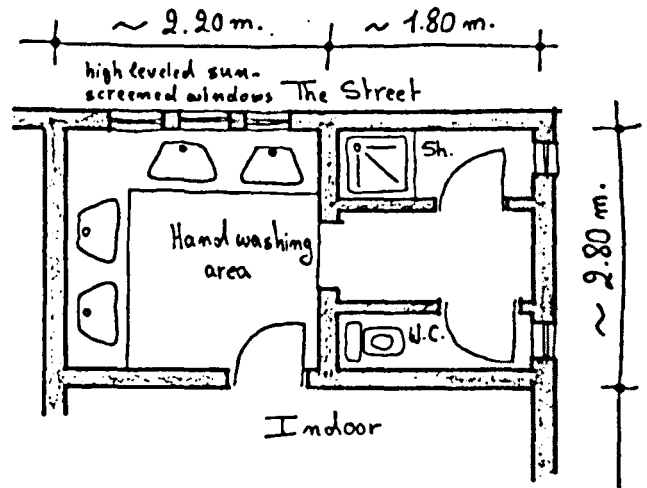

Fig 10 : A sketch that shows hand washing area, w.c., and shower.

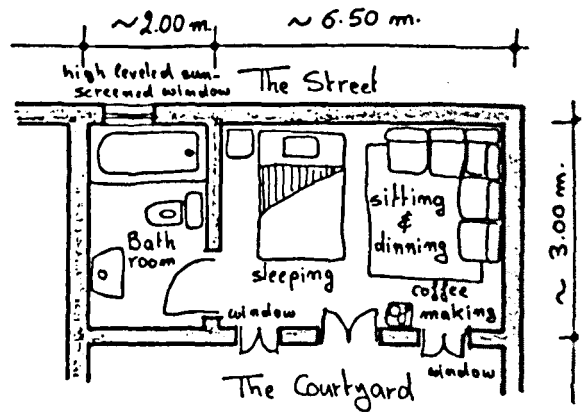

Fig 11 : A sketch that shows the servant's room.

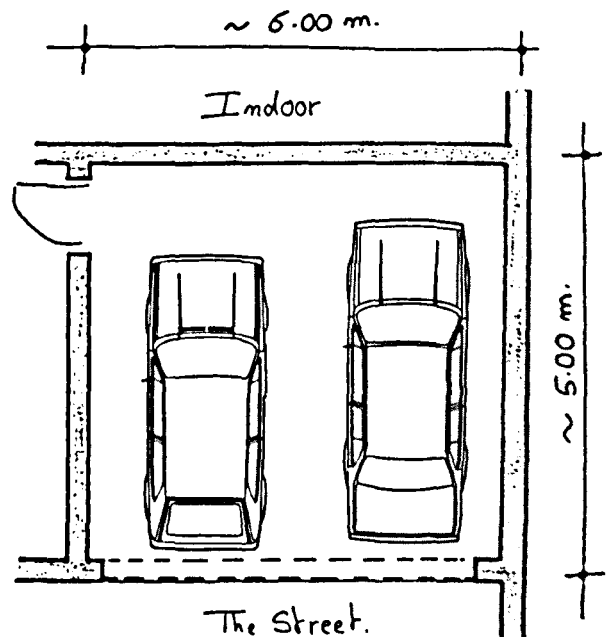

Fig 12 : A sketch that shows the garage.

Space type	Surface area in sq m.			N° of average surface area/ dwelling unit size				Total average surface area/ dwelling unit size			
	min	aver	opt	A	B	C	D	A	B	C	D
Family rooms	20										
		25									
		30		1	2	3	4	30	60	90	120
			36								
Bathrooms	6			1	2	2	2	6	12	12	12
		9		1	1	2	3	9	9	18	27
			12								
Family living rooms	30			1				30			
		38			1	1			38	38	
			48				1				48
Guests reception "Majlis"	30			1				30			
		38			1				38		
			48			1	1			48	48
Kitchen	12			1				12			
		16			1	1			16	16	
			20				1				20
Store	9			1				9			
		12			1	1			12	12	
			16				1				16
Car Garage	6										
		15		1	1	2	2	15	15	30	30
			25								
Servant's room	20						1				20
		25									
		30									
			36								
Total recommended built-up surface area for each dwelling unit size = sq.m.								141	200	264	341

Fig 13 : A table that shows four different space programmes of low-income houses, recommended by the author, with respect to the four different family sizes of the Abu Dhabi society.

Dwelling Unit Size :-

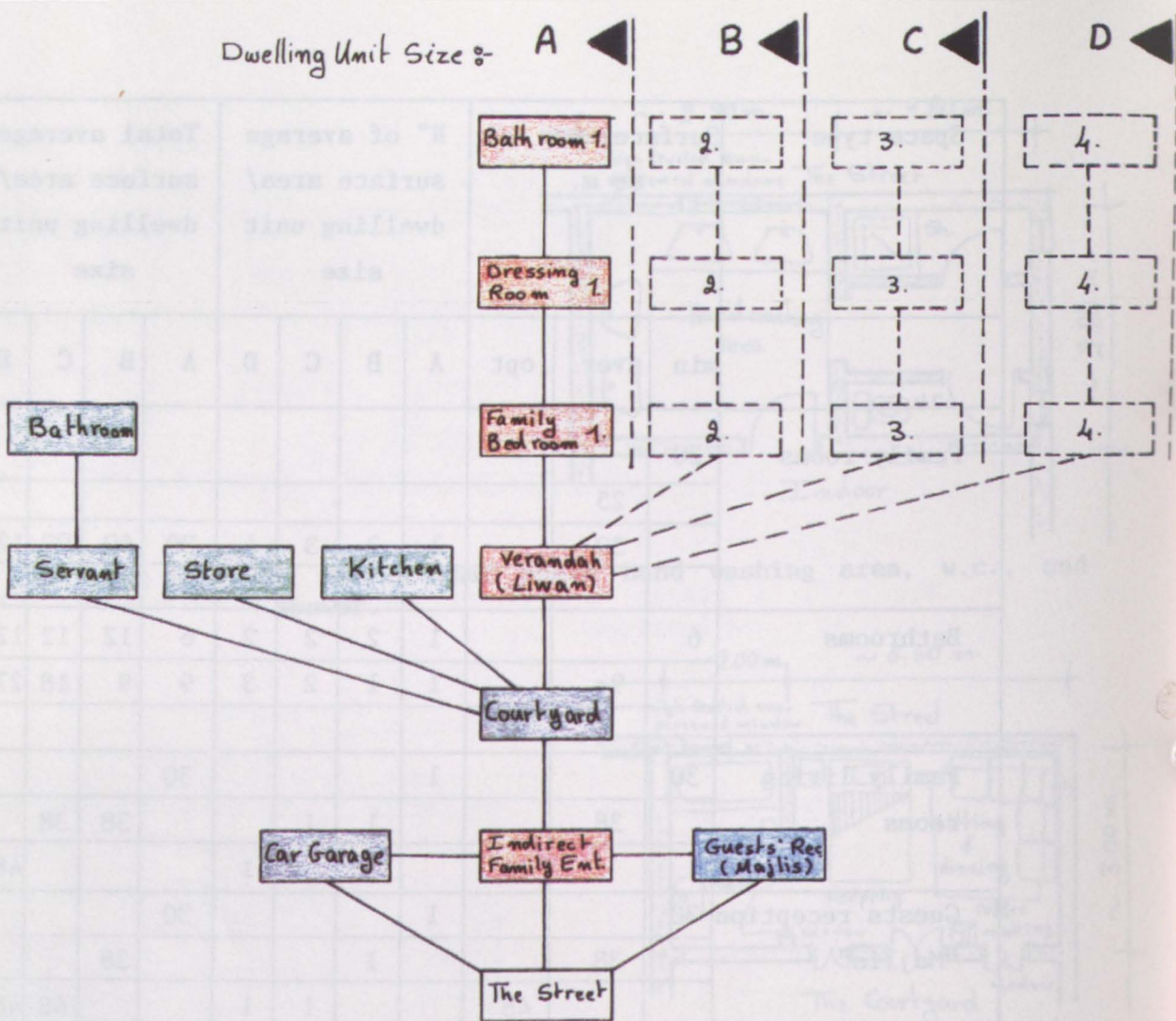
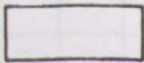

Fig 14 : A map that shows the recommended hierarchical spatial organization of the low-income houses in Abu Dhabi.

Key :



a space in the house



a step from one space to another

Note : This map is based on the direct accessibility from one space to the other, and on the method of the justified gamma maps (2).

4.1.6 Privacy

The design of dwelling units should provide privacy for the occupants.

The different spaces of the dwelling unit, which constitute the dwelling unit three main zones, should be laid out in a sequential, highly impermeable (to strangers), hierarchical spatial organisation (see Fig 14).

The degree of impermeability of a space should be the result of its depth within the dwelling unit layout. The increasing depth of different spaces in the dwelling unit should be governed by the degree of privacy required by each space.

The privacy of each space in the dwelling unit should be achieved by controlling the immediate audio/visual inspection between its different spaces, with respect to the activities carried out in them (see Fig 15).

Walls between dwelling unit's different spaces should conform with the criteria for airborne sound insulation within a dwelling unit shown below (1):

Partition function between rooms	STC : Sound transmission class		
	Opt	Aver	Min
	Grade I	Grade II	Grade III
bedroom to bedroom	48	44	40
living room to bedroom	50	46	42
bathroom to bedroom	52	48	45
kitchen to bedroom	52	48	45
bathroom to living room	52	48	45

Walls between dwelling unit's spaces and public space or the courtyard should conform with 55 STC as a sound transmission limitation.

Doors leading to bedrooms and bathrooms should be of solid-core construction and gasketed to assure a comfortable degree of privacy (1).

The privacy of the households' outdoor private area, the

Fig 15a : A map that shows the recommended types of aural communication between different spaces of the low-income houses in Abu Dhabi.

Key :

———— indirect aural
 - - - - - direct aural

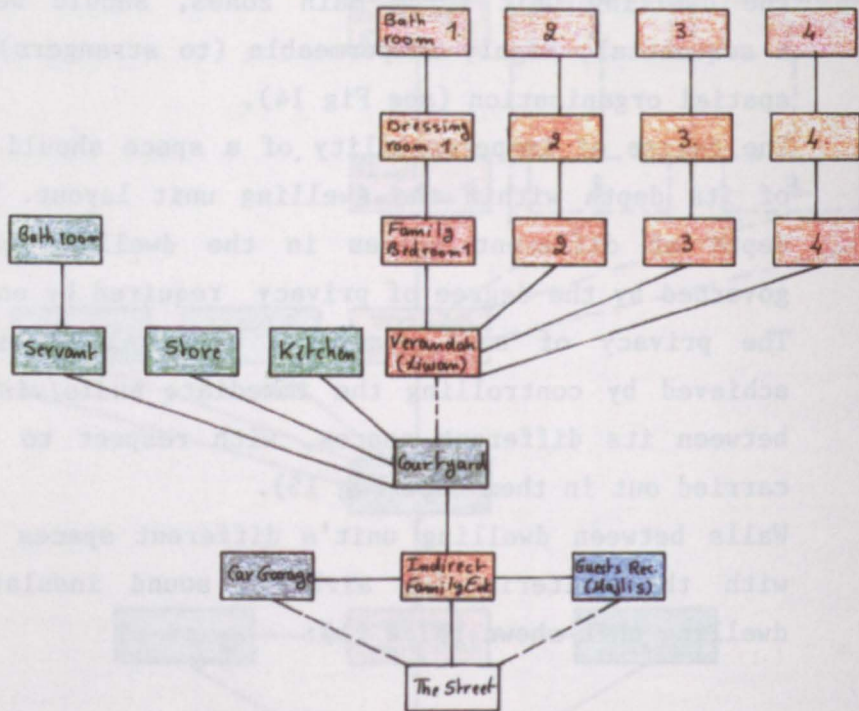
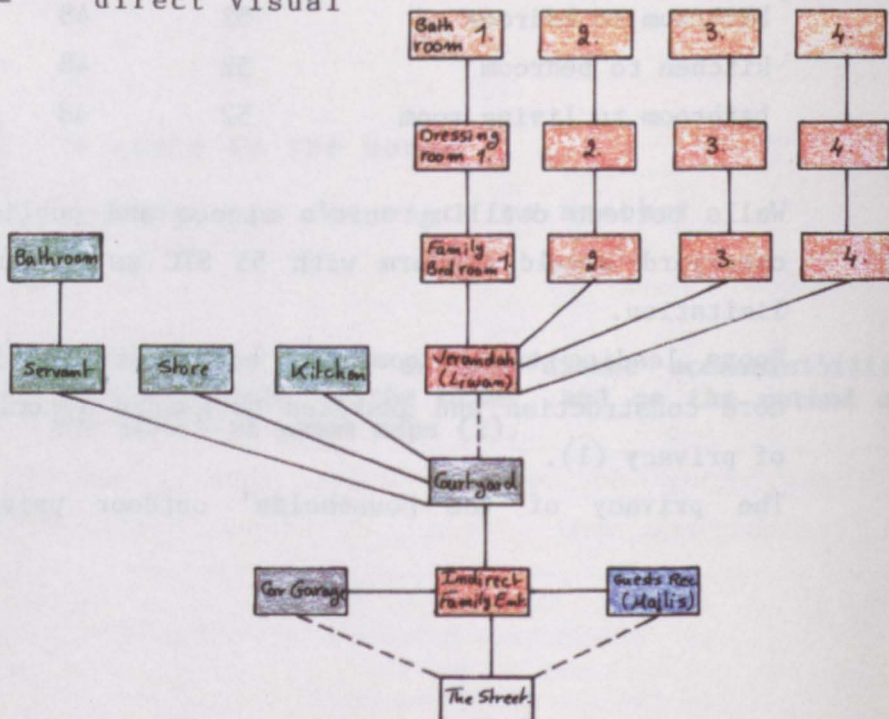

Fig 15b : A map that shows the recommended types of vial communication between different spaces of the low-income houses in Abu Dhabi.

Key :

———— indirect visual
 - - - - - direct visual



163A

Note : Maps shown in Figs 15a & 15b are based on the immediate audio/visual inspection from any space on the next permeable one (3).

courtyard, should be maintained. A boundary wall should surround the courtyard. It should be of sufficient height to prevent immediate visual inspection from the street on the courtyard. Boundary wall different heights:

- less than 2.5 m. (not acceptable)
- between 2.50 & 3.00 (acceptable)
- between 3.00 & 3.50 (preferable & recommended by the Planning Department of Abu Dhabi).

The family / women's zone and the services zone should overlook the courtyard and not the outdoor public area.

The guests / men's zone should neither overlook the family / women's zone, nor the services zone nor the family courtyard. The family indirect entrance should not allow immediate audio/visual inspection from the outdoor public area even when the door is opened.

4.1.7 Design standards regarding climatical conditions

Dwelling units design should provide comfortable environmental living conditions.

Dwelling units designed for hot / dry areas should conform with the following:

The house buildings should be of rectangular shapes. The ratio of the breadth to the length should neither exceed 1 : 1.3 nor fall shorter than 1 : 1.6.

The orientation of the house buildings should be east to south-eastern, where surfaces exposed to the sun should be reduced as much as possible.

Non habitable rooms (stores, kitchens, toilets, etc. ...) should be used as thermal barriers by being planned and placed on the east and/or the west ends of the house buildings.

Sun protection should be provided. Projecting roofs, verandahs, shading devices, trees, sunscreens and the surrounding boundary walls should be adopted as basic sun protection

techniques.

Care should be taken to use materials of low thermal capacity for shading devices close to openings, to ensure their quick cooling after sun set.

The buildings roofs should be of flat horizontal surfaces, where sometimes the households sleep on top of the roof in hot summer nights.

Thermal transmittance (or U value) of walls and particularly roofs should not exceed $U = 0.6 \text{ w/m}^2 \text{ }^\circ\text{C}$

The buildings should have maximum contact with the ground. Ground floors should be solid , not suspended, and in no case should the building be built on stilts (4).

Exterior walls and roofs should be of low heat absorbing colours.

The window width should be equal to twice the thickness of the wall bearing it.

Windows should be of double glazed panels reflecting minimum 60% of the solar radiation. They should be timber framed. Thermal transmittance (or U value) of windows should not exceed $U = 1 \text{ w/m}^2 \text{ }^\circ\text{C}$.

Windows acting as air inlets over looking the courtyard should be located low on the walls in order to benefit from the cool air pond at night and the shade in the morning. Windows do not over look the courtyard should be narrow and located high on the walls, admitting little heat and dust, and reducing ground glare effect on the interior of the dwelling unit areas.

Accessisible roofs' parapets should be of 90-120 cm. high. Parapets of non accessisible roofs should be of 0.45-0.60 metres. All parapets should be perforated to allow air circulation as close as possible to the roof to help cooling

its exterior surface, and thick enough to avoid visual inspection, from the street, on the top of the low roofs. High solid parapets should be avoided, where they will create a stagnant pool of hot air on the top of the roof surface. Heat source buildings such as kitchens should be isolated and separately ventilated (4).

Dwelling units designed for hot / humid areas should conform with the same standards mentioned above, except for the following:

The house buildings should also be of rectangular shapes but the ratio of the breadth to length in this case should neither exceed 1 : 1.7 nor fall shorter than 1 : 3.

The orientation of the house buildings should be north to north-western.

Air inlets should be facing the direction of the cool prevailing winds, and should be narrower than the air outlets. Windows acting as air outlets should be located on the opposite walls to those of the air inlets, thus maintaining the required natural cross ventilation. Air outlets should be protected by sun screens, where they will be facing south to south-eastern. They can also be protected by wood louvered shutters where they maintain subdued light, privacy and ventilation. They have good thermal performance (8).

Sun screens should provide 100% shading starting from sun altitude angle of 60°.

In case of not applying mechanical air conditioning systems, the use of the wind scoop system such as the wind-tower "al'Barjeel" should be adopted.

4.1.8 Technical standards

The housing design in Abu Dhabi should conform with the

following technical standards:

The applied construction methods and materials should conform with the building regulations adopted by the local building authorities of Abu Dhabi.

Utilised building materials should conform with the technical safety measurements in order to guarantee a sound construction.

The house ground floor should be raised above the ground level by an average of one to three steps, thus preventing dust and reptiles from entering the house.

The applied structure systems should allow future expansion of the house constituents without affecting the soundness of the buildings. Future expansion should be achieved without obliging the households to move out during construction period.

The house buildings should be maintained regularly, in order to assure the safety of the households.

4 . 2 D e v e l o p i n g l a y o u t p a r a m e t e r s f o r g r o u p s o f h o u s e s

Layout of groups of houses in Abu Dhabi forming neighbourhoods, which consist of different sizes of houses, should conform with the following layout parameters :

Houses should be laid out together in groups forming mini-neighbourhoods (see Fig 16). The layout of these houses should create complex patterns of streets visually impermeable to strangers.

These patterns of streets should be linked together with a chain of relatively small piazzas or open spaces which contain a small mosque, and are used as points of social contacts and help increasing the amount of shade and coolness.

The maximum distance between a house and any of these piazzas in a mini-neighbourhood should be between 350 & 400 metres (5). Segregation between drive ways and walk ways should be achieved in order to offer the inhabitants protected pedestrian network (see Fig 17).

Houses should be aligned close to each other to achieve mutual shading and maintain air channelling between houses with respect to the prevailing wind directions.

The ratio of the width of the street to the height of the surrounding boundary walls should be equal to 1.5-3.00, therefore increasing shaded areas of the streets and achieve mutual shading between the houses exterior walls.

Green areas should be integrated in the neighbourhood planning programme, where they are used for social contacts and gatherings. They also help reducing the area of glare reflecting surfaces.

In hot/dry areas water pools, fountains should be integrated in the neighbourhood design.

Two or three mini-neighbourhoods forming a complete

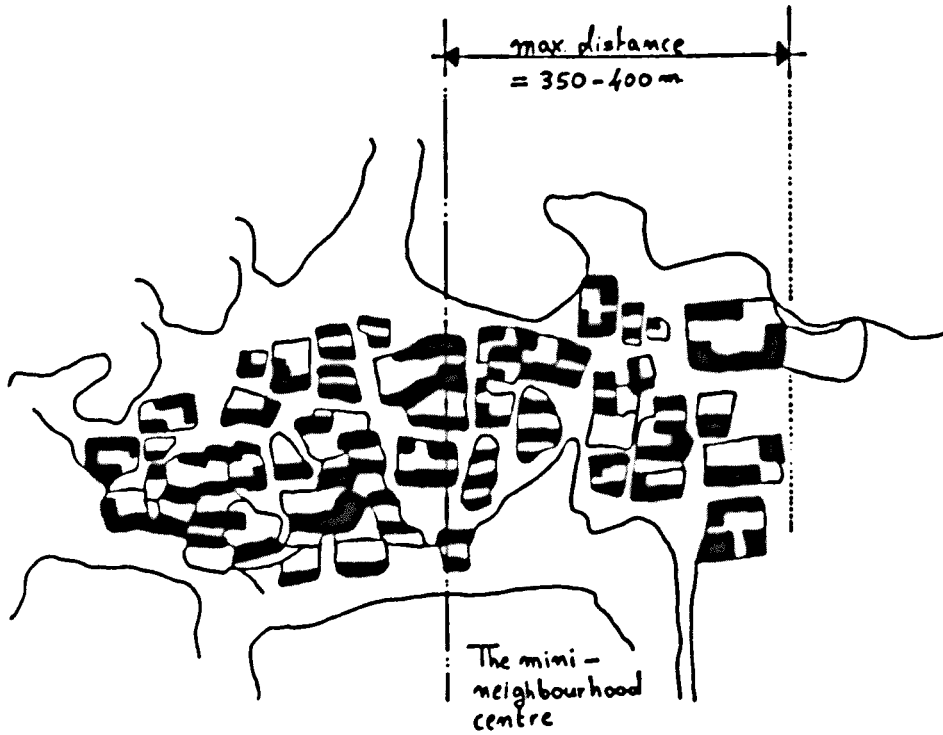
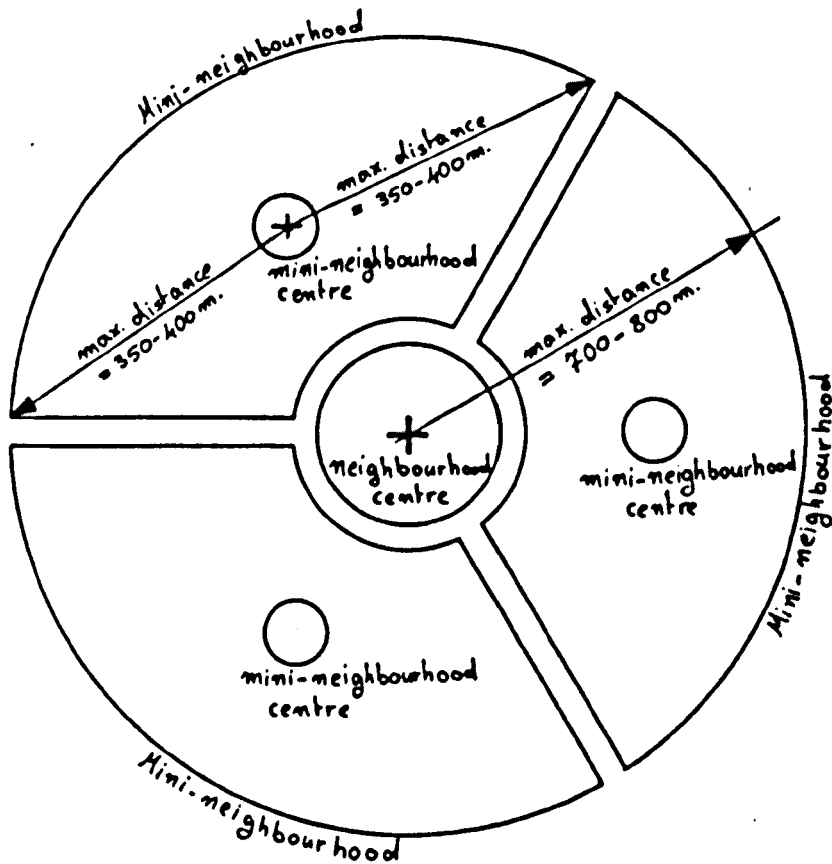

Fig 16a : A sketch that shows an example for a mini-neighbourhood. (6)



168A

Fig 16b : The neighbourhood.

neighbourhood should be laid out around the central piazza which contains the shopping centre, the friday mosque, the secondary school, the public library, a social exhibition centre, the post office, a municipality office, police station, fire department station, 8 grossary shops, 2 pharmacies, 4 bouchers / fish / poultry, 2 stationarays, 2 children toy shops, 4 women's wear, 2 men's wear, 1 gift's shop, house equipments, 1 electrical appliances, 2 restaurants. The average surface area of a shop should be around 20m² (5). The radius definning the exterior limits of a neighbourhood is the maximum distance one can walk in hot weather which is between 700 & 800 metres (5).

The maximum length of a street within the neighbourhood should not exceed 350 - 400 metres long.

The width of a pedestrien walkway should not be wider than 2.4 - 3.00 metres.

Neighbourhood & mini-neighbourhood sizes

The size of the mini-neighbourhood is defined according to the sizes of the primary and preparatory schools and the number of each within the mini-neighbourhood.

Thus : primary school size = 450 pupils

2 primary schools needed = 2x450 = 900 pupils

preparatory school size =300 pupils

2 preparatory schools needed = 2x300 = 600 pupils

The primary school pupils' age % of the population = 13.3%
(7).

The preparatory school pupils age % of the population = 10.6%
(7).

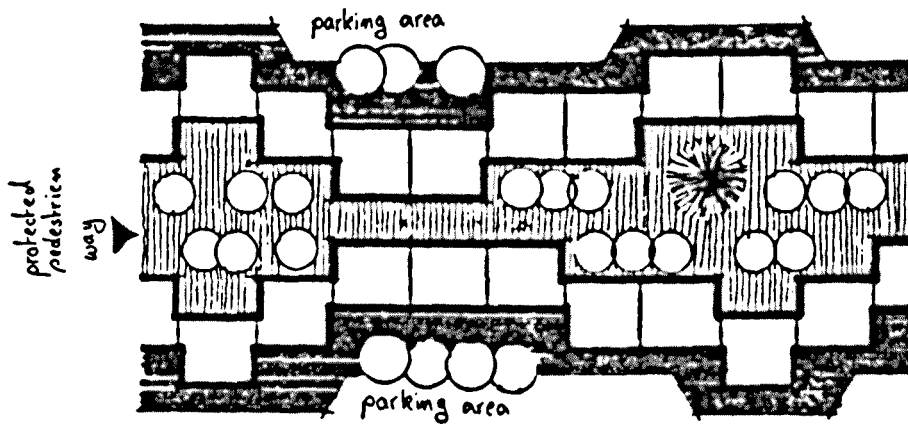

Fig 17 : A sketch that shows how segregation between drive ways and walk ways can be achieved.

The size of the mini-neighbourhood varies :
from $600/0.106 = 5700$ persons
to $900/0.133 = 6800$ persons

The neighbourhood size is either double or triple that of the mini-neighbourhood. Thus the minimum and the maximum sizes of the neighbourhood vary as follow:

Minimum size: from 11400 to 13600 persons.

Maximum size: from 17100 to 20400 persons.

Since the average size of the family is 7 persons

Thus number of families per mini-neighbourhood =

$(5700+6800)/2 = 6250$ persons; $6250/7 = 890$ families

Since each family lives in a separate dwelling unit, and the dwelling unit average plot area is = 441 m^2

Thus, the surface area needed for dwelling units per mini-neighbourhood = $890 \text{ families} \times 441 \text{ m}^2 = 39.25 \text{ H.};$

Therefore, the surface area needed for dwelling units per neighbourhood varies from : $2 \times 39.25 = 78.50 \text{ H.}$

to : $3 \times 39.25 = 117.75 \text{ H.}$

The net density of the mini-neighbourhood is equal to that of the neighbourhood, which is :

$6250 \text{ persons} / 39.25 \text{ H.} = 159.24 \text{ persons/H.}$

List of Quotations

- (1) Callender, J. H., "Time-Saver Standards For Architectural Design Data", 6th ed, New York, 1982, p 4-44
- (2) Hillier, B. & Hanson, J., "The Social Logic of Space", London, 1984, pp 147-152
- (3) Broadbent, G., "Design in Architecture - Architecture and the Human Sciences", London, 1973, pp 262, 263
- (4) Koenigsberger, O. H., et al, "Manual of tropical housing and building", Part One: Climatic design, London, 1974, pp 203-212
- (5) Ibrahim, A. B., "Originating Civilizational Values In Building The Contemporary Islamic City", Cairo, 1982, pp 126-131, (Title translated by the author).
- (6) Ibrahim, M. A., "The Gulf Architecture Between Originality And Renovation", Part Two, Cairo, 1972, p 99, (Title translated by the author).
- (7) Department of Planning, "Statistical Year Book", Abu Dhabi, 1984, p 20
- (8) Holm, D., "Energy Conservation In Hot Climates", London, 1983, p 36

List of Figures

- Figure 4/1 : A diagram that shows the recommended communication degrees between the house different zones.
- Figure 4/2 : A sketch that shows the skimming air flow regime.
- Figure 4/3 : A sketch that shows the semi-enclosed courtyard and maintaining air channeling around the dwelling unit buildings.
- Figure 4/4 : A sketch that shows integrating trees, and water pools within the courtyard design.
- Figure 4/5 : Different sketches that show dwelling unit direct and indirect entrances and accesses.
- Figure 4/6 : A sketch that shows the indirect family/women's entrance.
- Figure 4/7 : A sketch that shows family bedroom, dressing room, and bathroom.
- Figure 4/8 : A sketch that shows family livingrom.
- Figure 4/9 : A sketch that shows guests/men's reception "al'Majlis".
- Figure 4/10 : A sketch that shows hand washing area, w.c., and shower.
- Figure 4/11 : A sketch that shows the servant's room.
- Figure 4/12 : A sketch that shows the garage.
- Figure 4/13 : A table that shows four different space programes of low income houses, recommended by the aouthor, with respect to the four different family sizes of the Abu Dhabi society.
- Figure 4/14 : A map that shows the recommended hierarchical spatial organization of the low income houses in Abu Dhabi.
- Figure 4/15a : A map that shows the recommended types of aural communication between different spaces of the low income houses in Abu Dhabi.
- Figure 4/15b : A map that shows the recommended types of vial communication between different spaces of the low income houses in Abu Dhabi.
- Figure 4/16a : A sketch that shows an example for a mini-neighbourhood.

Figure 4/16b : The neighbourhood.

Figure 4/17 : A sketch that shows how segregation between drive ways and walk ways can be achieved.

Chapter Five

Developing, evaluating and selecting dwelling unit layouts and groups of houses

In this chapter various dwelling unit layouts will be systematically designed following the established criteria in chapter four. They will then be evaluated and successful ones will be presented. A design solution for mini-neighbourhoods in Abu Dhabi will, then, be proposed using the successful dwelling units with respect to the layout parameters for groups of houses developed in chapter four.

This chapter will be structured as follow:

5.1 The dwelling units design solutions, which will be of two types:

- * Type I for hot and dry climate
- * Type II for hot and humid climate

5.2 The mini-neighbourhood proposed design solution.

5.1 The dwelling unit design solutions

Dwelling unit design solutions will be of two types: I & II Type I will be classed by sizes of different solutions, and type II will be classed by solutions of different sizes (see Socio-cultural background of the local people). Taking into consideration that families living by the coast expand within the same family house, while other families living on the main land do not, a future expansion zone within every plot area is feasible for solutions type II. Satisfying all criteria mentioned in chapter four-part one, these designs will be evaluated according to three eliminating yardsticks which are in the following order:

- a The courtyard shape: it should allow free usage of the given surface area within a certain shape, and should maintain skimming air flow regime for type I and air channelling around the house buildings for type II. The courtyard shape will be evaluated as follow: Desirable = 4; Tolerable = 3; Undesirable = 2; Intolerable = 1. If a courtyard shape achieves 3 or 4 points the design solution will proceed to other evaluating yardsticks, and if it achieves 2 or 1 point will be directly eliminated.
- b The location of the kitchen compared to the other constituents of the house. Determining weather, it allows or not, odours to be carried away by prevailing winds to the house. That is with respect to the dwelling unit orientation recommended by the author. Solutions that allow kitchen odours to be carried away to the house buildings will be given the sign "X", other solutions which do not will be given the sign "O". Any solution which carries the sign "X" will be directly eliminated.
- c The built-up surface area of the design solution, where only design solutions with the nearest built-up surface area to that recommended by the author in chapter three (see Fig 13 - ch 3) will be finally selected and presented as examples for possible solutions for both types I & II.

Results will be summarised in a table following each group of possible design solutions showing the selected ones. Proposed elevations by the author and recommended typical details will be presented for the successful dwelling unit layouts.

D e s i g n S o l u t i o n s T y p e I

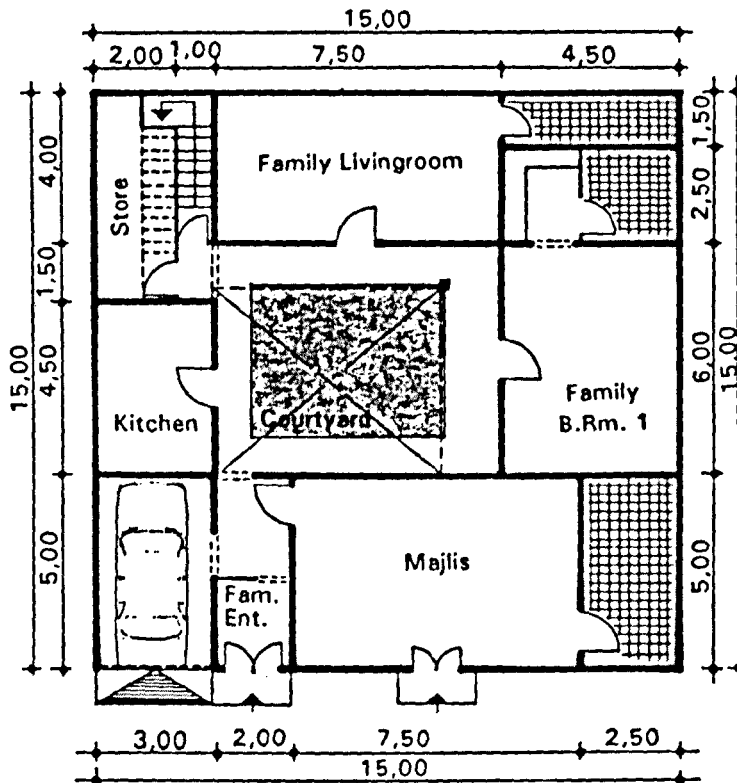

Fig 1 : Size A Solution 1
Scale 1:200

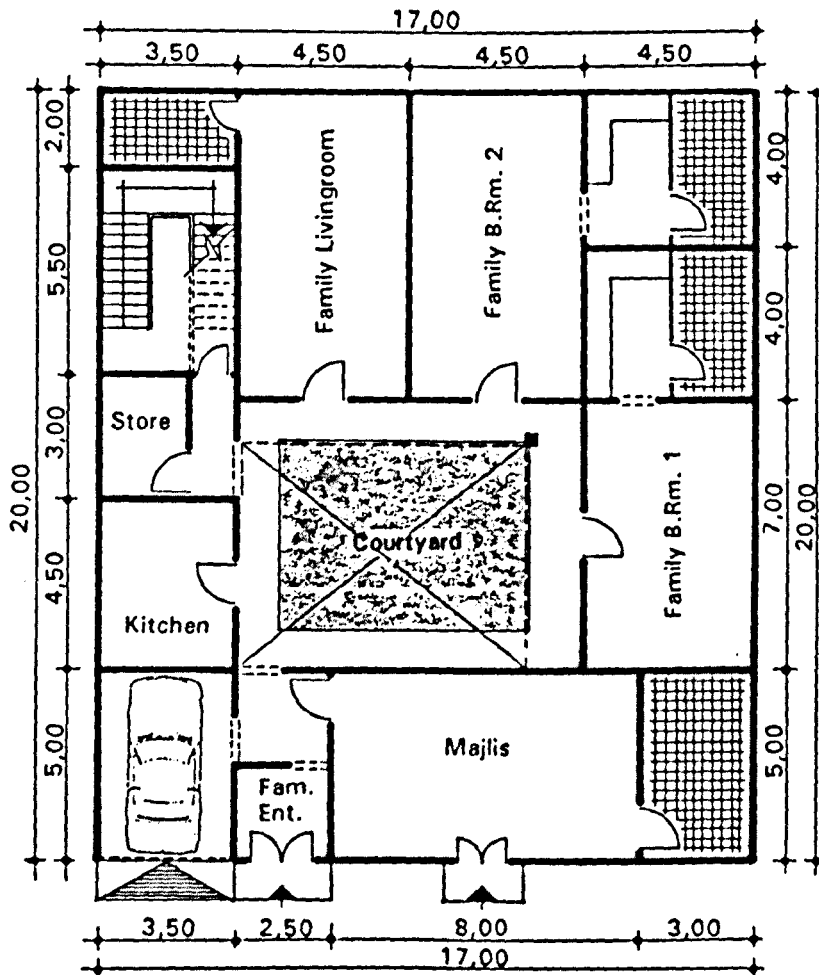

Fig 2 : Size B Solution 1
Scale 1:200

173A

Size A - Solution 1

a The courtyard is of a rectangular shape which allows skimming air flow regime.

b Kitchen does not allow bad smells to be carried away to the house buildings.

c The built-up surface area = 165.05 m²

Plot surface area = 225.00 m²

Ratio of built-up surface area to plot surface area is:

$$165.05 / 225.00 = 73.35 \%$$

Size B - Solution 1

a The courtyard is of a rectangular shape which allows skimming air flow regime.

b Kitchen does not allow bad smells to be carried away to the house buildings.

c The built-up surface area = 256.50 m²

Plot surface area = 340.00 m²

Ratio of built-up surface area to plot surface area is:

$$256.50 / 340.00 = 75.44 \%$$

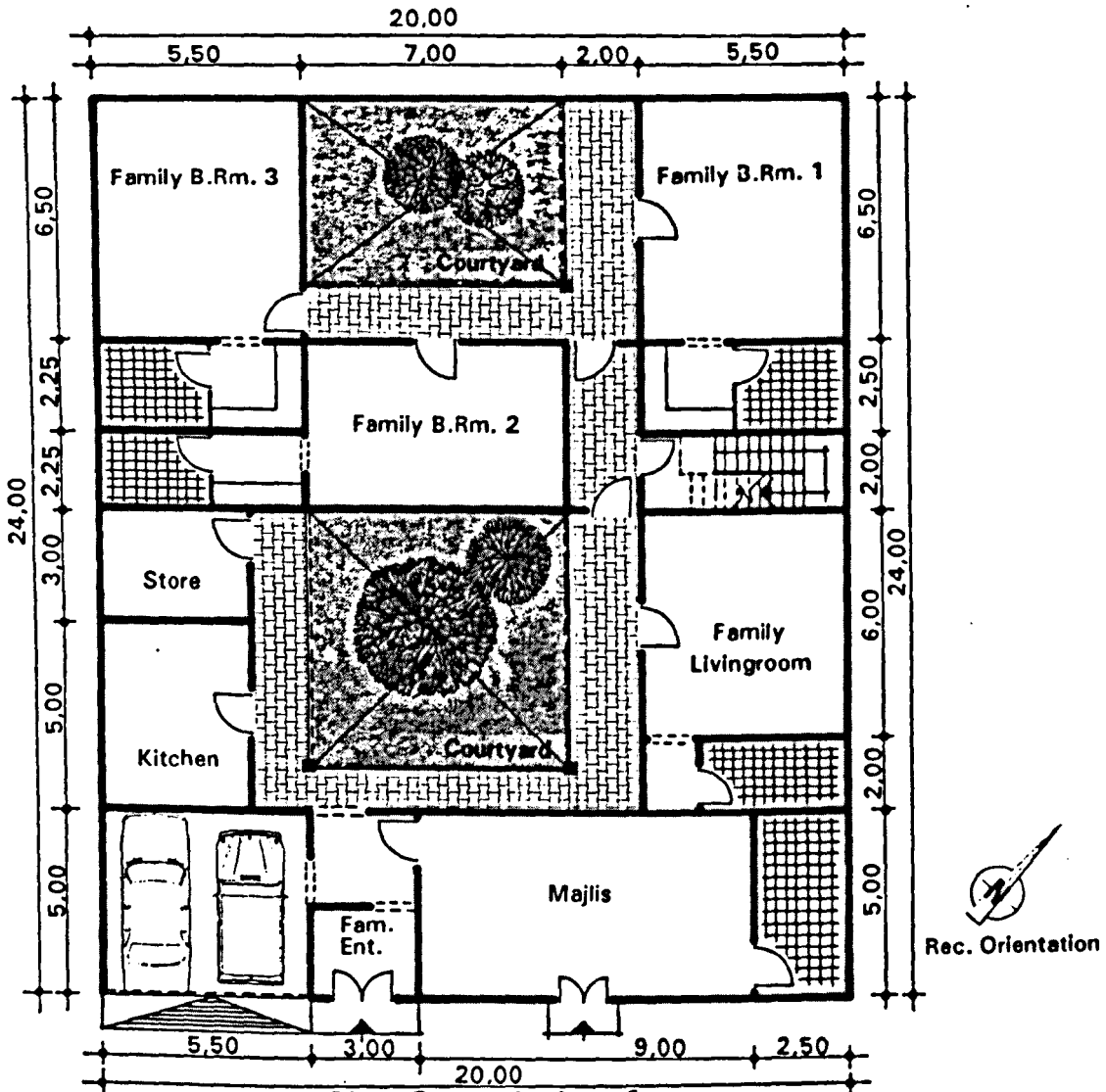

Fig 3 : Size C Solution 1
Scale 1:200

Size C - Solution 1

a The courtyards are of rectangular and square shapes, where both courtyards allow a skimming air flow regime.

b Kitchen does not allow bad smells to be carried away to the house buildings.

c The built-up surface area = 273.50 m²

Plot surface area = 480.00 m²

Ratio of built-up surface area to plot surface area is:

$$273.50 / 480.00 = 56.98 \%$$

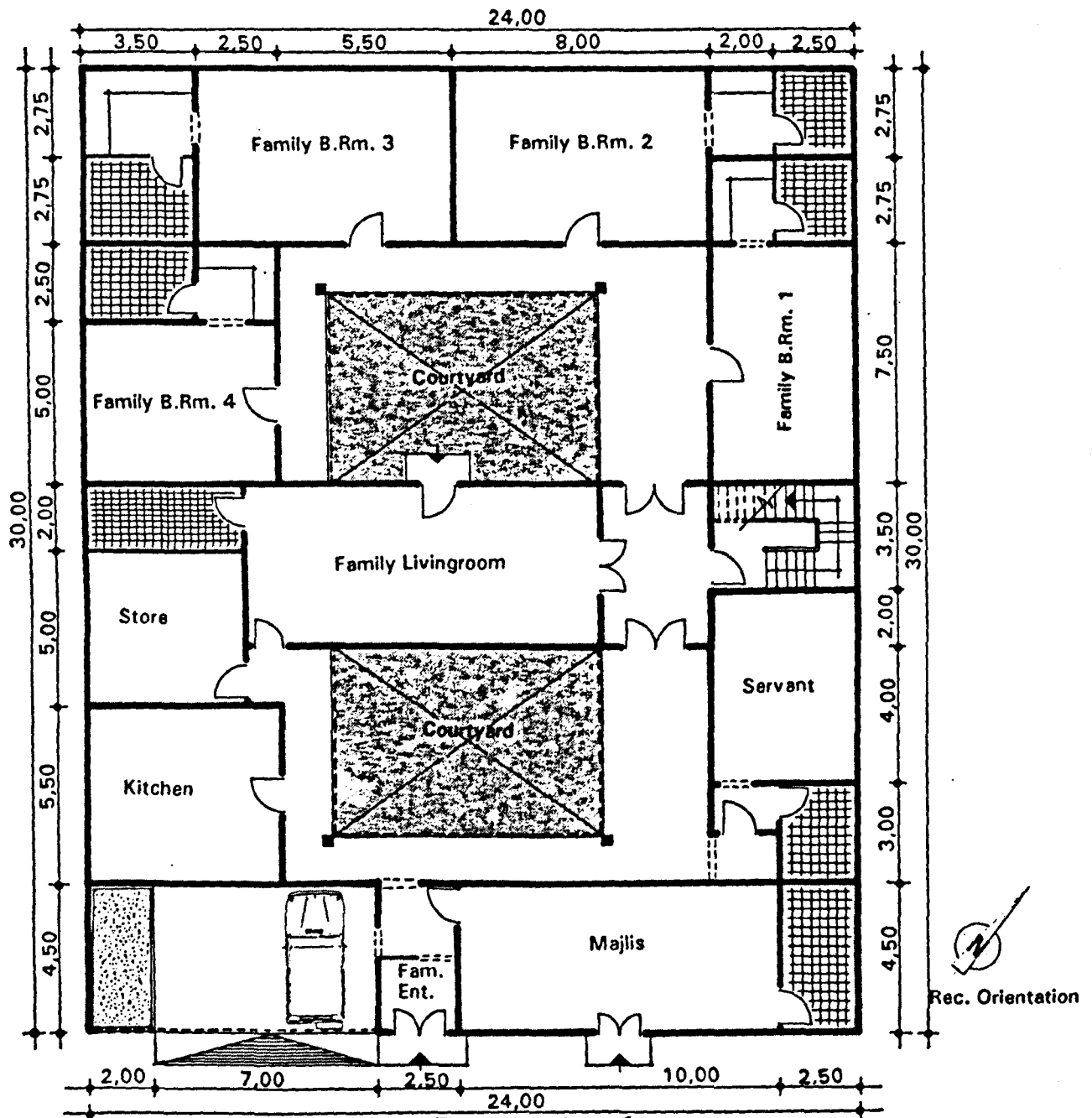

Fig 4 : Size D Solution 1
Scale 1:200

Size D - Solution 1

a The courtyards are of rectangular shapes, where both courtyards allow skimming air flow regime.

b Kitchen does not allow bad smells to be carried away to the house buildings.

c The built-up surface area = 444.25 m^2

Plot surface area = 720.00 m^2

Ratio of built-up surface area to plot surface area is:

$$444.25 / 720.00 = 61.70 \%$$

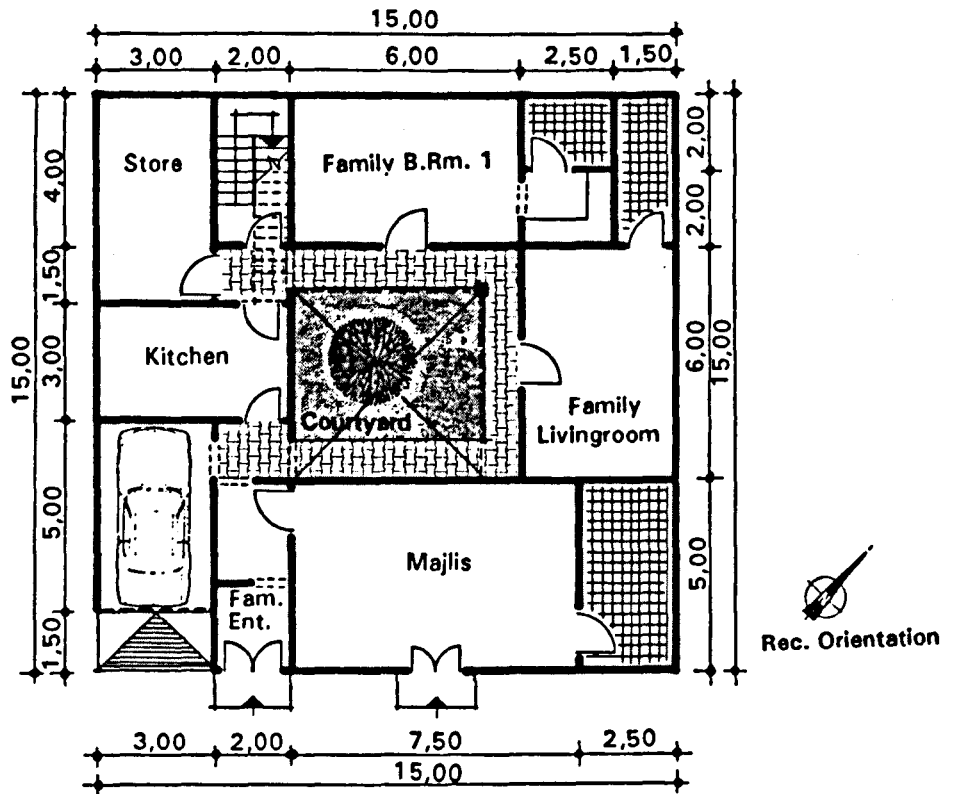

Fig 5 : Size A Solution 2
Scale 1:200

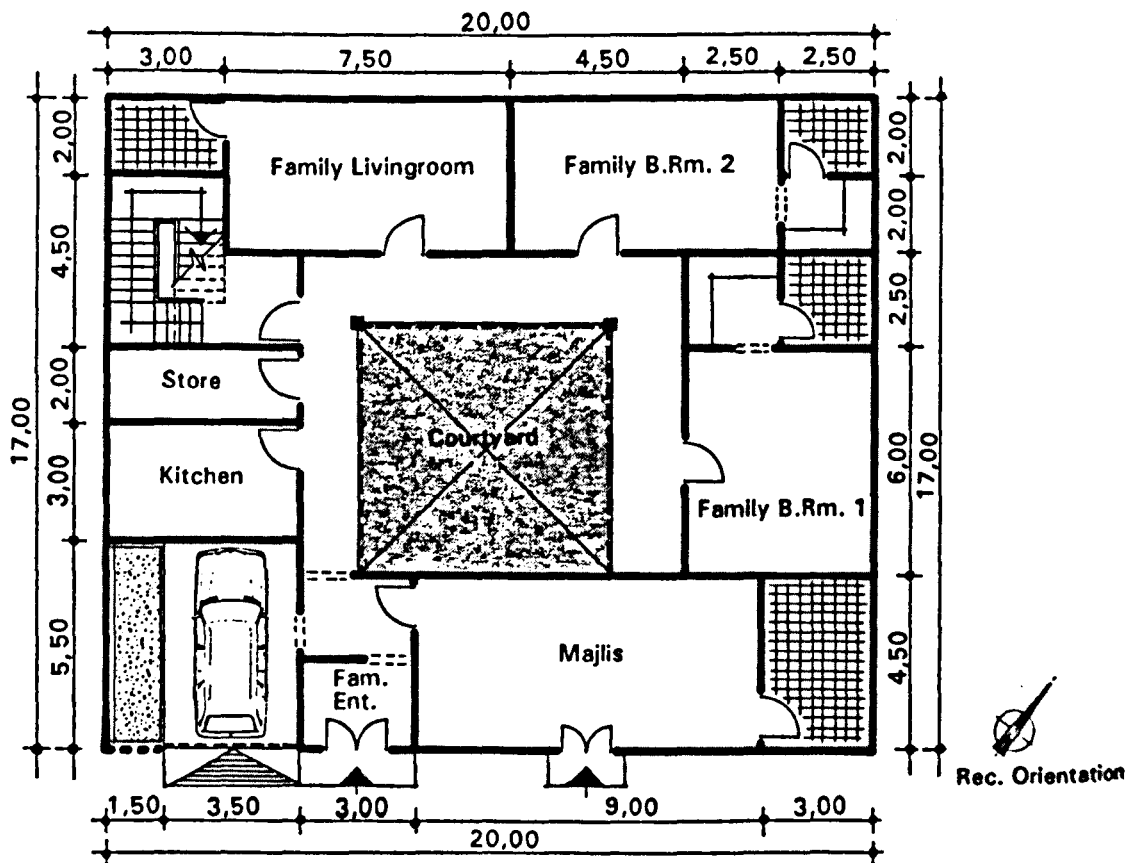

Fig 6 : Size B Solution 2
Scale 1:200

176A

Size A - Solution 2

- a The courtyard is of a square shape which allows skimming air flow regime.
- b Kitchen does not allow bad smells to be carried away to the house buildings.
- c The built-up surface area = 161.60 m^2
Plot surface area = 225.00 m^2
Ratio of built-up surface area to plot surface area is:
 $161.60 / 225.00 = 71.82 \%$

Size B - Solution 2

- a The courtyard is of a square shape which allows skimming air flow regime.
- b Kitchen does not allow bad smells to be carried away to the house buildings.
- c The built-up surface area = 215.50 m^2
Plot surface area = 340.00 m^2
Ratio of built-up surface area to plot surface area is:
 $215.50 / 340.00 = 63.38 \%$

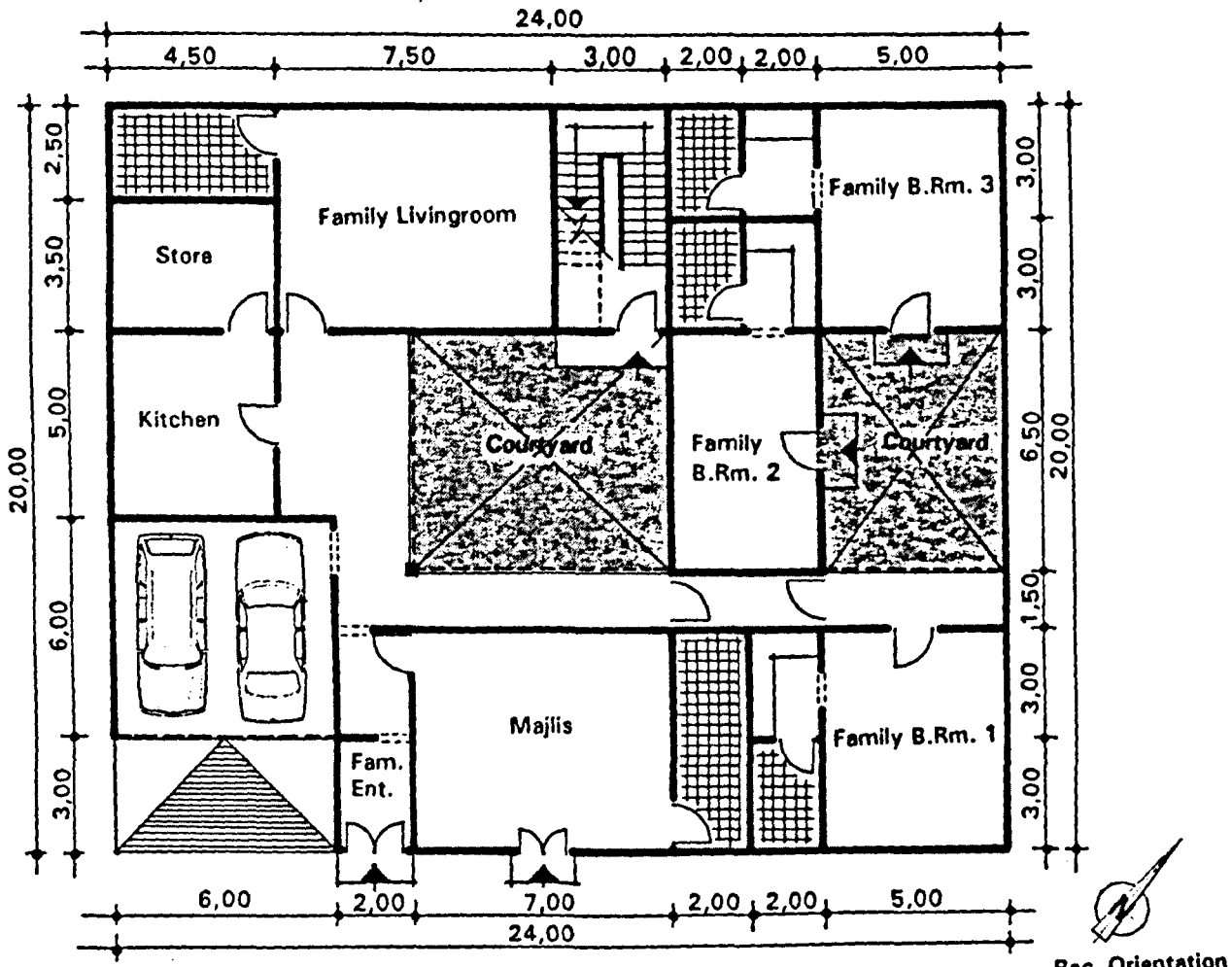

Fig 7 : Size C Solution 2

Scale 1:200

Size C - Solution 2

a The courtyards are of rectangular and square shapes, where both courtyards allow a skimming air flow regime.

b Kitchen does not allow bad smells to be carried away to the house buildings.

c The built-up surface area = 308.50 m^2

Plot surface area = 480.00 m^2

Ratio of built-up surface area to plot surface area is:

$$308.50 / 480.00 = 64.27 \%$$

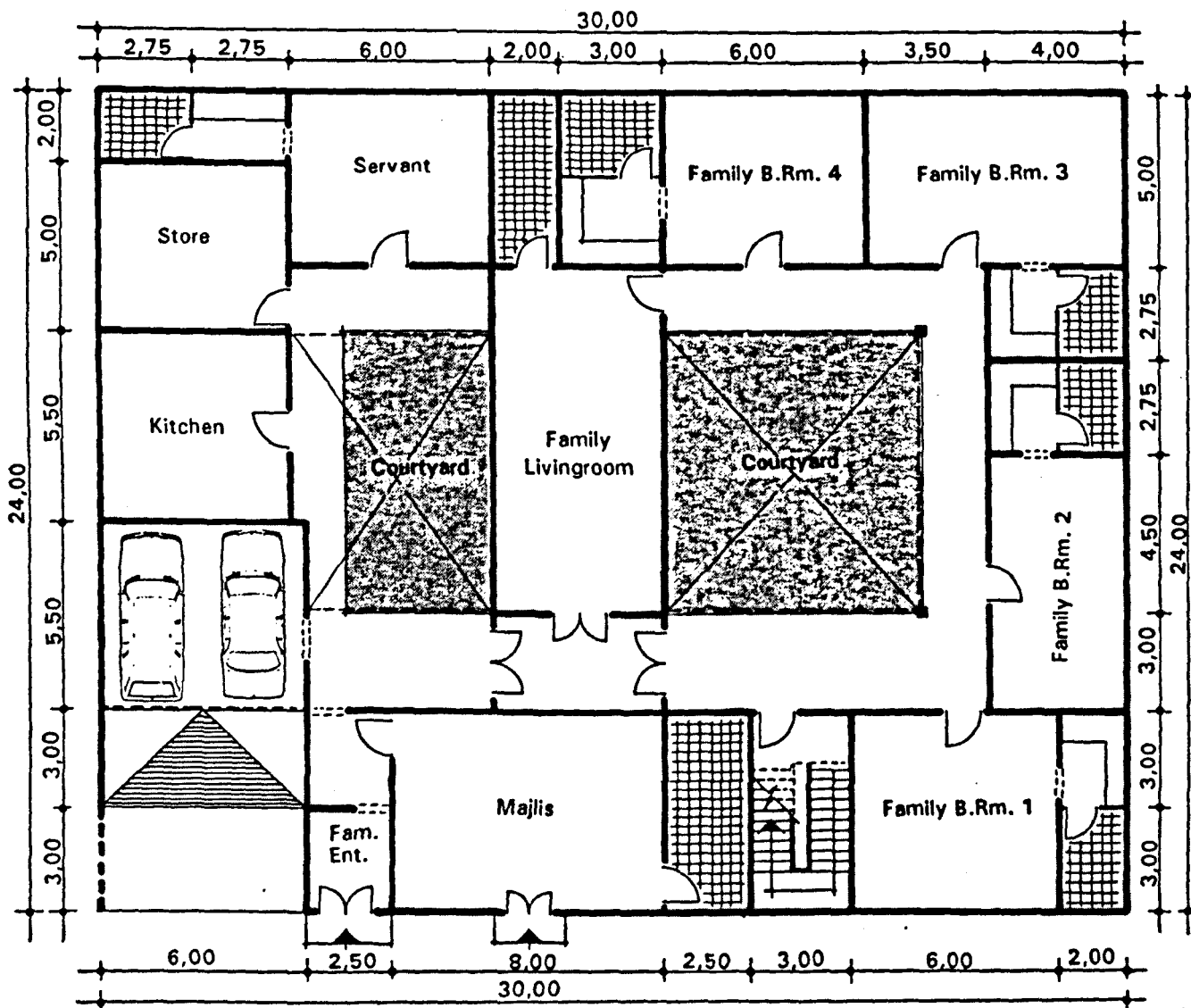

Fig 8 : Size D Solution 2
Scale 1:200



Size D - Solution 2

a The courtyards are of rectangular shapes, where both courtyards allow skimming air flow regime.

b Kitchen does not allow bad smells to be carried away to the house buildings.

c The built-up surface area = 439.00 m²

Plot surface area = 720.00 m²

Ratio of built-up surface area to plot surface area is:

$$439.00 / 720.00 = 60.97 \%$$

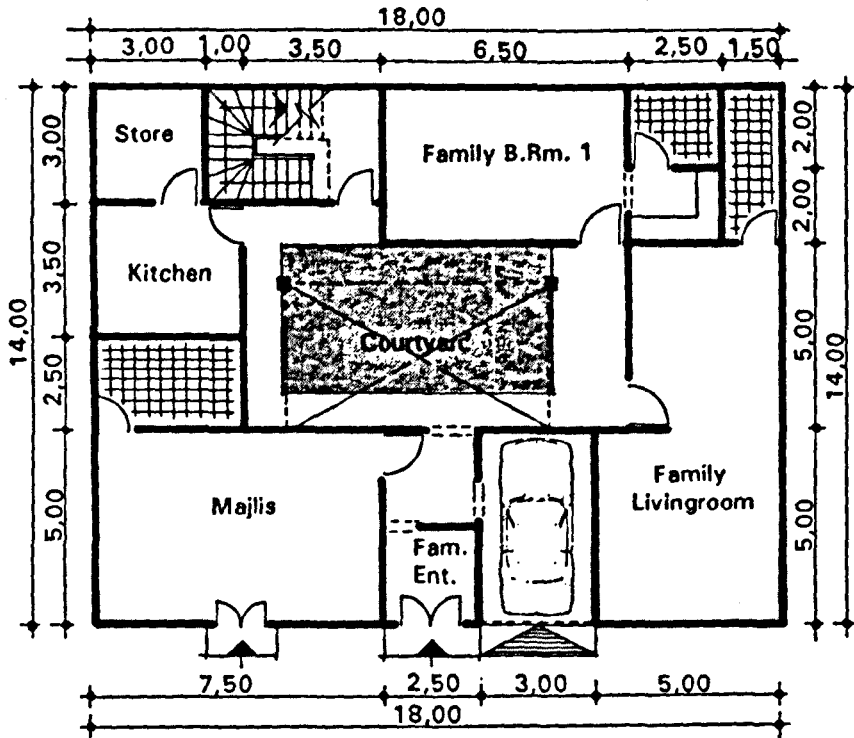

Rec. Orientation

Fig 9 : Size A Solution 3
Scale 1:200

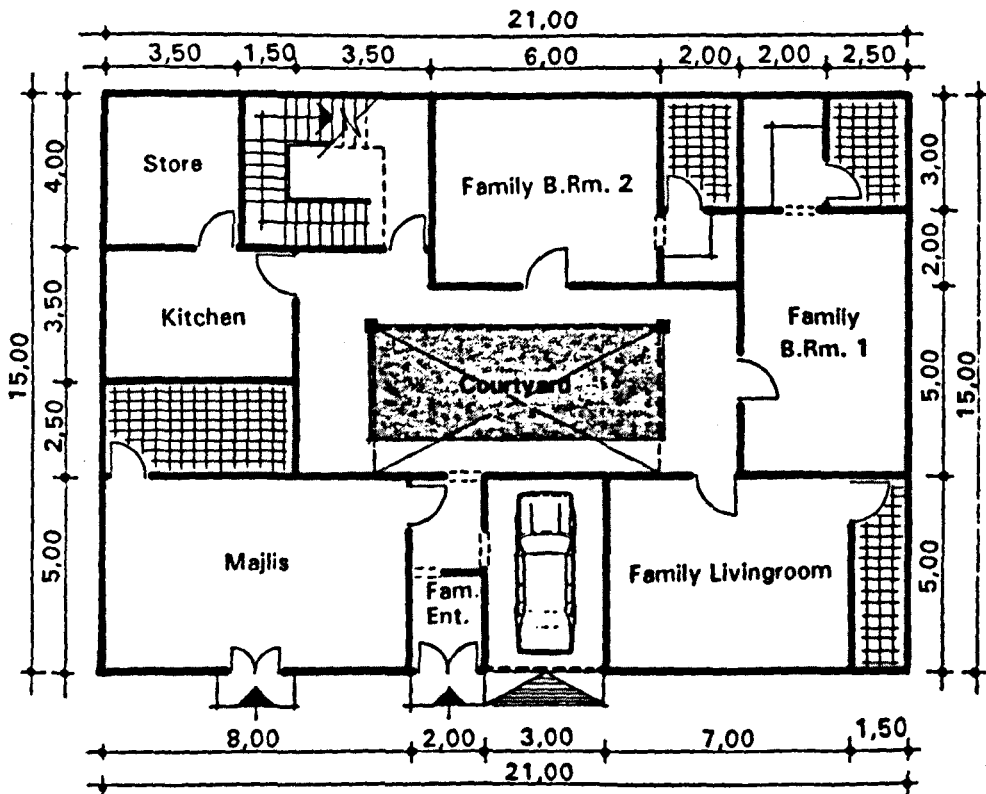

179A

Rec. Orientation

Fig 10 : Size B Solution 3
Scale 1:200

Size A - Solution 3

a The courtyard is of a rectangular shape which allows skimming air flow regime.

b Kitchen does not allow bad smells to be carried away to the house buildings.

c The built-up surface area = 175.00 m²

Plot surface area = 252.00 m²

Ratio of built-up surface area to plot surface area is:

$$175.00 / 252.00 = 69.44 \%$$

Size B - Solution 3

a The courtyard is of a rectangular shape which allows skimming air flow regime.

b Kitchen does not allow bad smells to be carried away to the house buildings.

c The built-up surface area = 224.00 m²

Plot surface area = 315.00 m²

Ratio of built-up surface area to plot surface area is:

$$224.00 / 315.00 = 71.11 \%$$

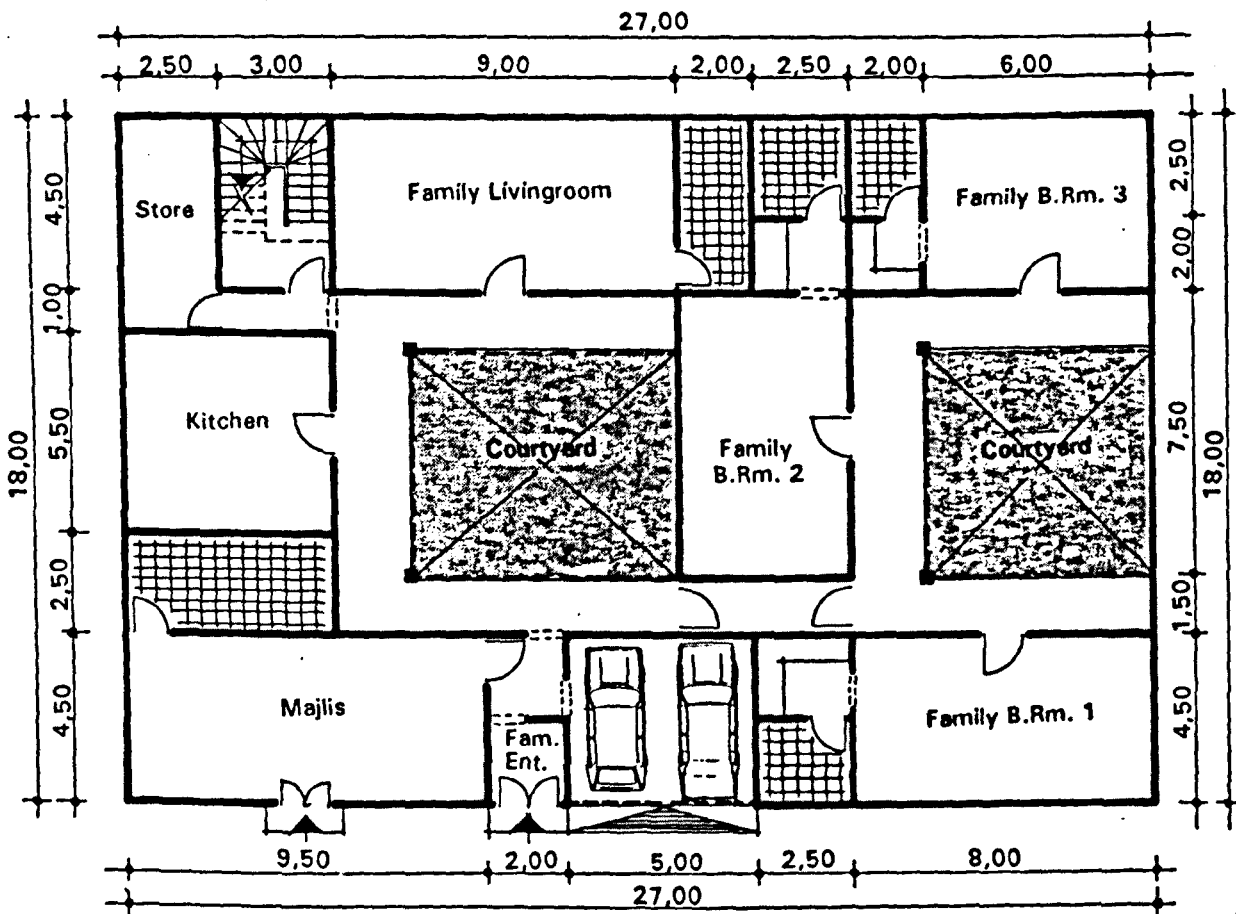

Fig 11 : Size C Solution 3
Scale 1:200



Size C - Solution 3

a The courtyards are of rectangular and square shapes, where both courtyards allow a skimming air flow regime.

b Kitchen does not allow bad smells to be carried away to the house buildings.

c The built-up surface area = 298.50 m^2

Plot surface area = 486.00 m^2

Ratio of built-up surface area to plot surface area is:

$$298.50 / 486.00 = 61.42 \%$$

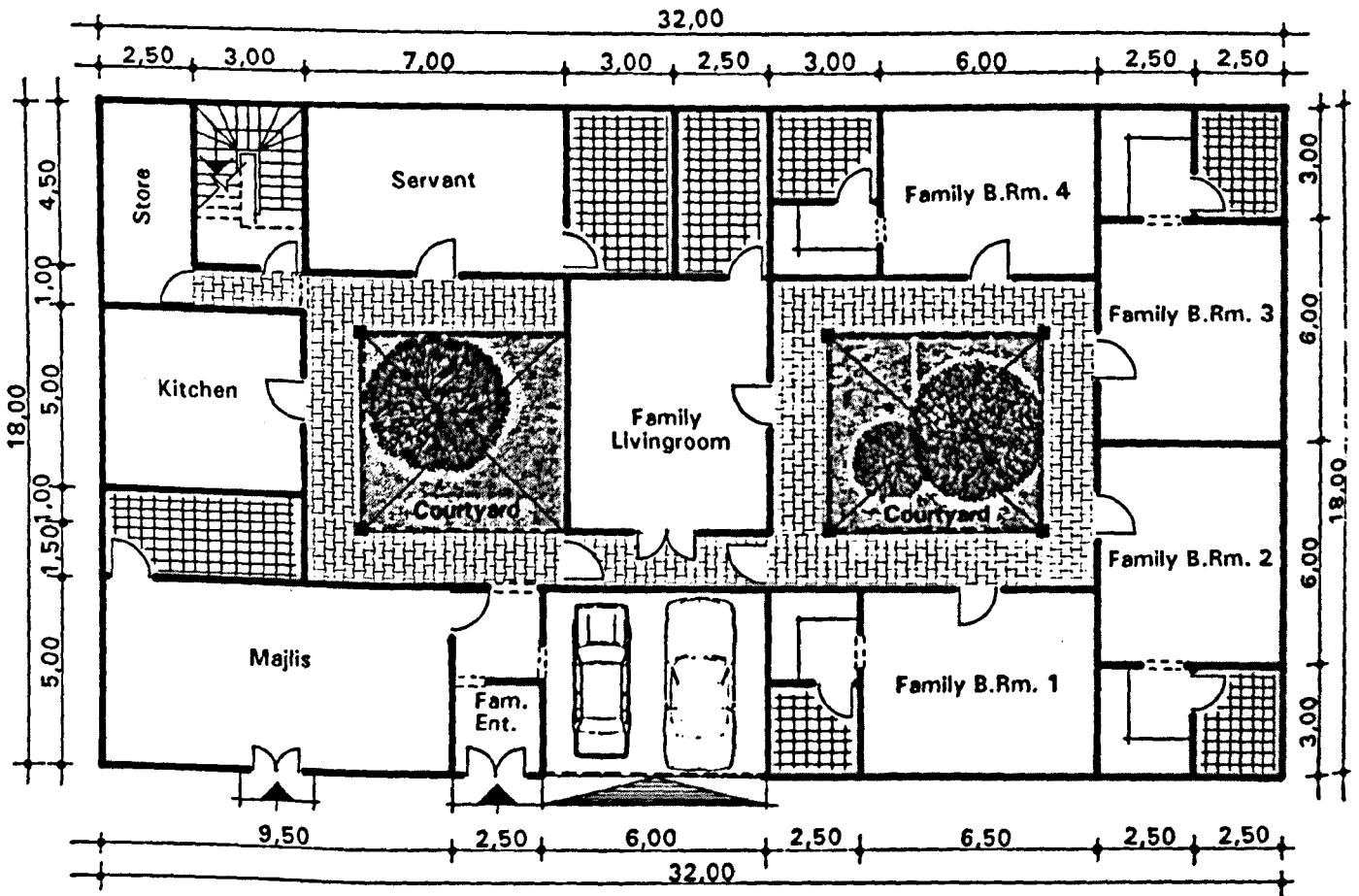

Fig 12 : Size D Solution 3
Scale 1:200



Rec. Orientation

Size D - Solution 3

a The courtyards are of rectangular shapes, where both courtyards allow skimming air flow regime.

b Kitchen does not allow bad smells to be carried away to the house buildings.

c The built-up surface area = 402.75 m^2

Plot surface area = 576.00 m^2

Ratio of built-up surface area to plot surface area is:

$$402.75 / 576.00 = 69.92 \%$$

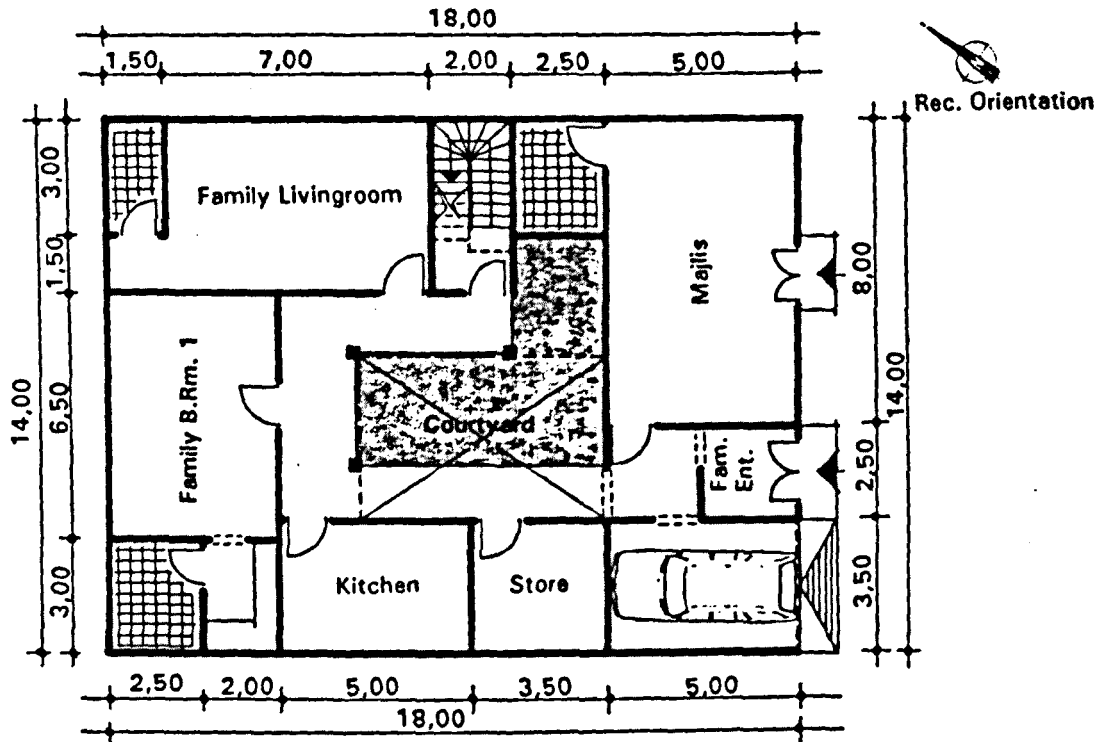

Fig 13 : Size A Solution 4
Scale 1:200

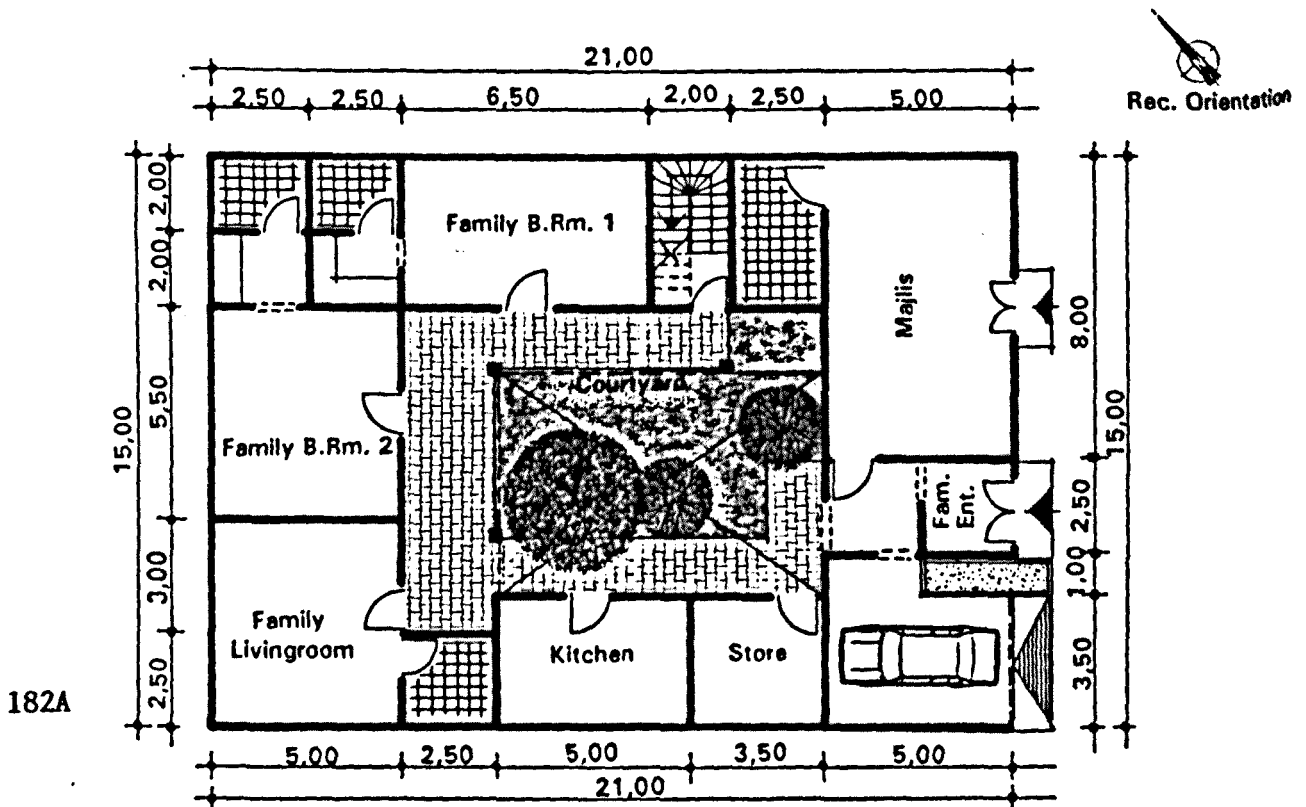

Fig 14 : Size B Solution 4
Scale 1:200

Size A - Solution 4

a The courtyard is of a rectangular shape which allows skimming air flow regime.

b Kitchen does not allow bad smells to be carried away to the house buildings.

c The built-up surface area = 177.90 m^2

Plot surface area = 252.00 m^2

Ratio of built-up surface area to plot surface area is:

$$177.90 / 252.00 = 70.59 \%$$

Size B - Solution 4

a The courtyard is of a rectangular shape which allows skimming air flow regime.

b Kitchen does not allow bad smells to be carried away to the house buildings.

c The built-up surface area = 203.25 m^2

Plot surface area = 315.00 m^2

Ratio of built-up surface area to plot surface area is:

$$203.25 / 315.00 = 64.52 \%$$

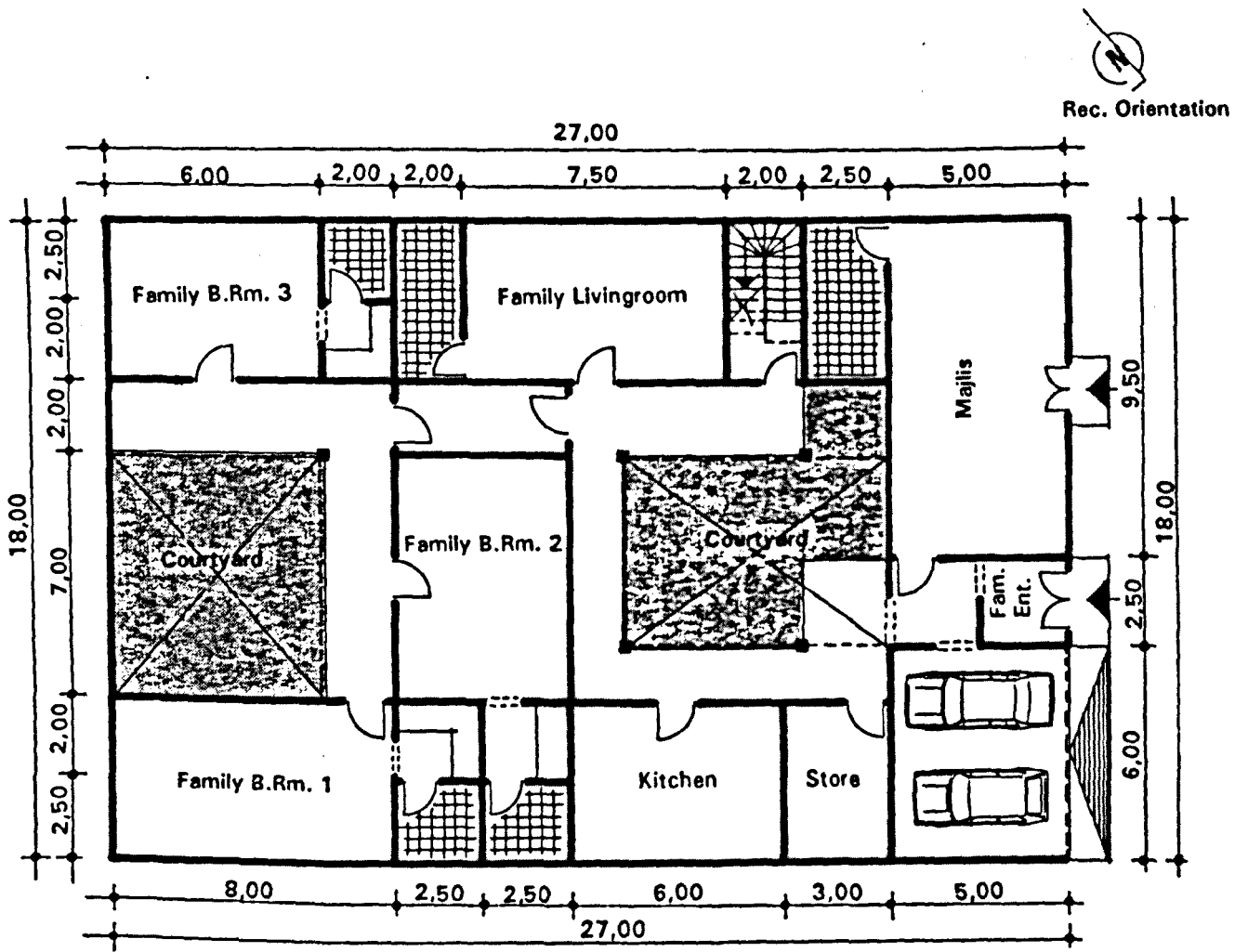

Fig 15 : Size C Solution 4
Scale 1:200

Size C - Solution 4

a The courtyards are of rectangular shapes, where both courtyards allow a skimming air flow regime.

b Kitchen does not allow bad smells to be carried away to the house buildings.

c The built-up surface area = 303.75 m^2

Plot surface area = 486.00 m^2

Ratio of built-up surface area to plot surface area is:

$$303.75 / 486.00 = 62.50 \%$$

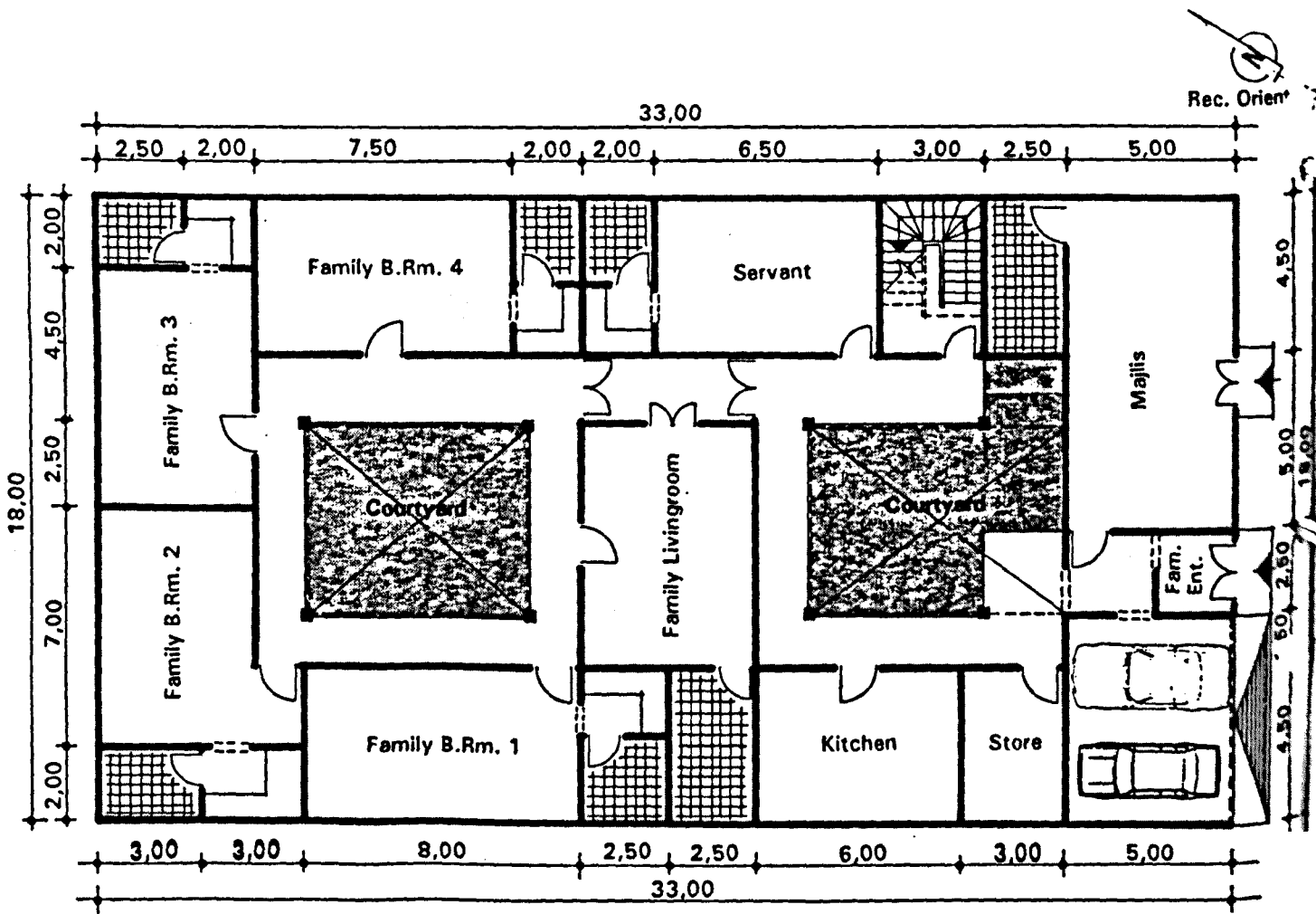

Fig 16 : Size D Solution 4

Scale 1:200

Size D - Solution 4

a The courtyards are of rectangular shapes, where both courtyards allow a skimming air flow regime.

b Kitchen does not allow bad smells to be carried away to the house buildings.

c The built-up surface area = 410.00 m²

Plot surface area = 594.00 m²

Ratio of built-up surface area to plot surface area is:

$$410.00 / 594.00 = 69.02 \%$$

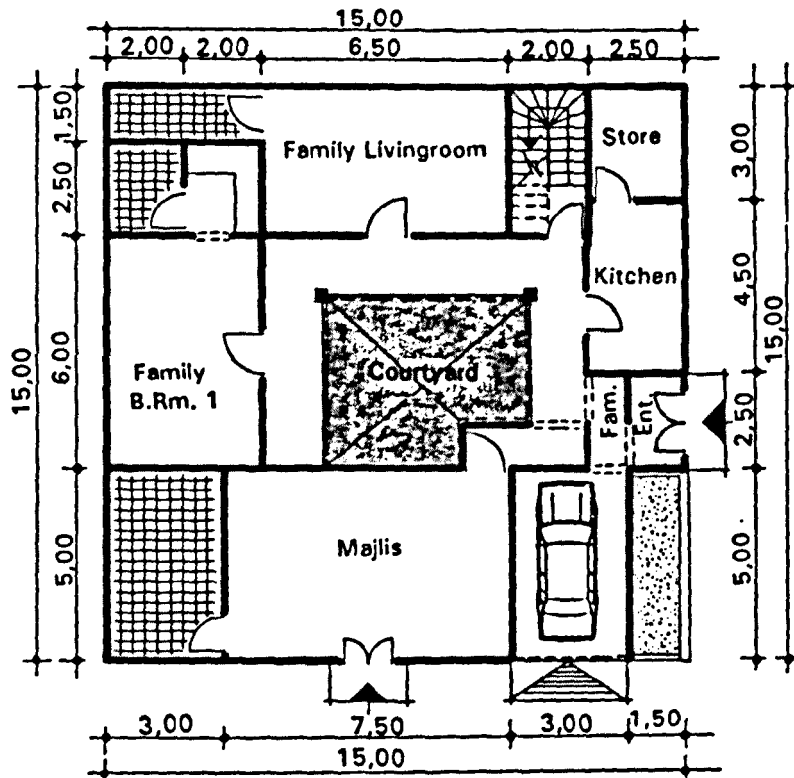

Fig 17 : Size A Solution 5
Scale 1:200

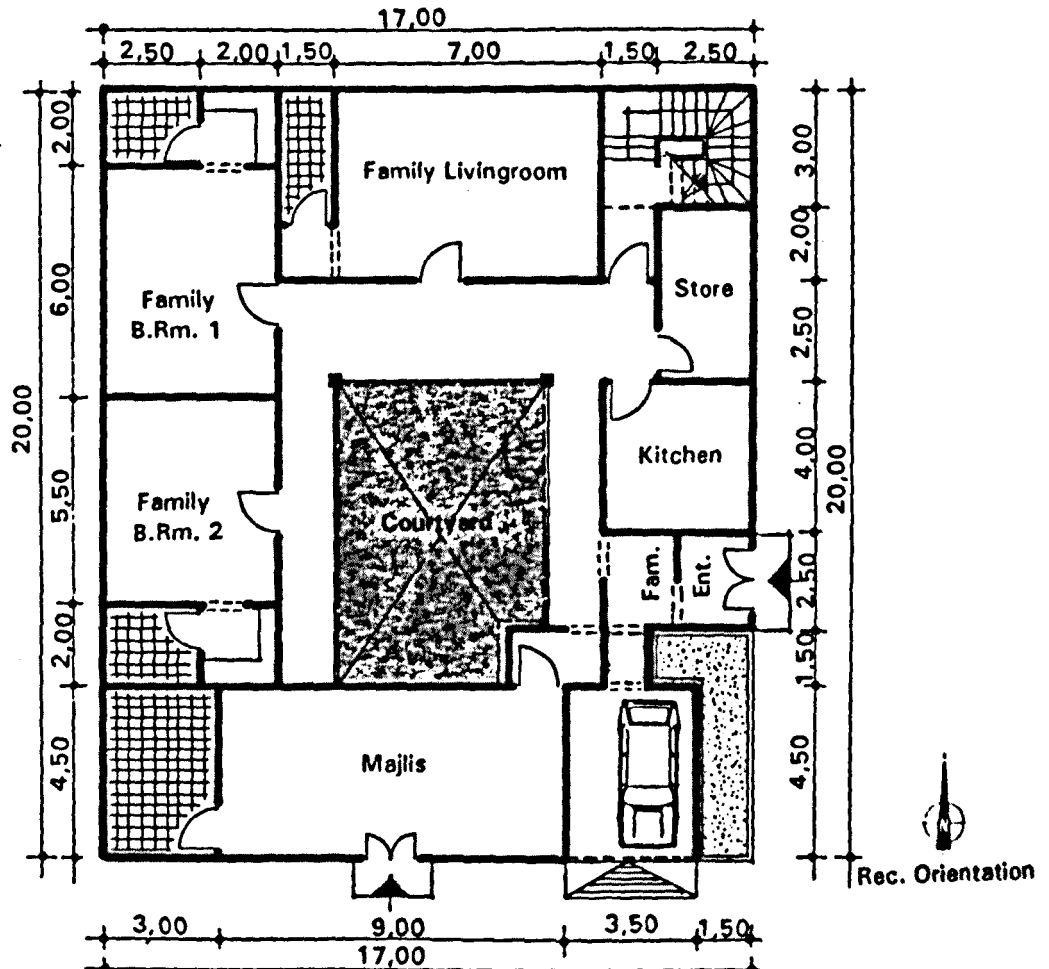

Fig 18 : Size B Solution 5
Scale 1:200

Size A - Solution 5

- a The courtyard is of a rectangular shape which does not allow skimming air flow regime.
- b Kitchen allows bad smells to be carried away to the house buildings.
- c The built-up surface area = 153.75 m^2
Plot surface area = 225.00 m^2
Ratio of built-up surface area to plot surface area is:
 $153.75 / 225.00 = 68.33 \%$

Size B - Solution 5

- a The courtyard is of a rectangular shape which allows skimming air flow regime.
- b Kitchen allows bad smells to be carried away to the house buildings.
- c The built-up surface area = 211.50 m^2
Plot surface area = 315.00 m^2
Ratio of built-up surface area to plot surface area is:
 $211.50 / 315.00 = 67.14 \%$

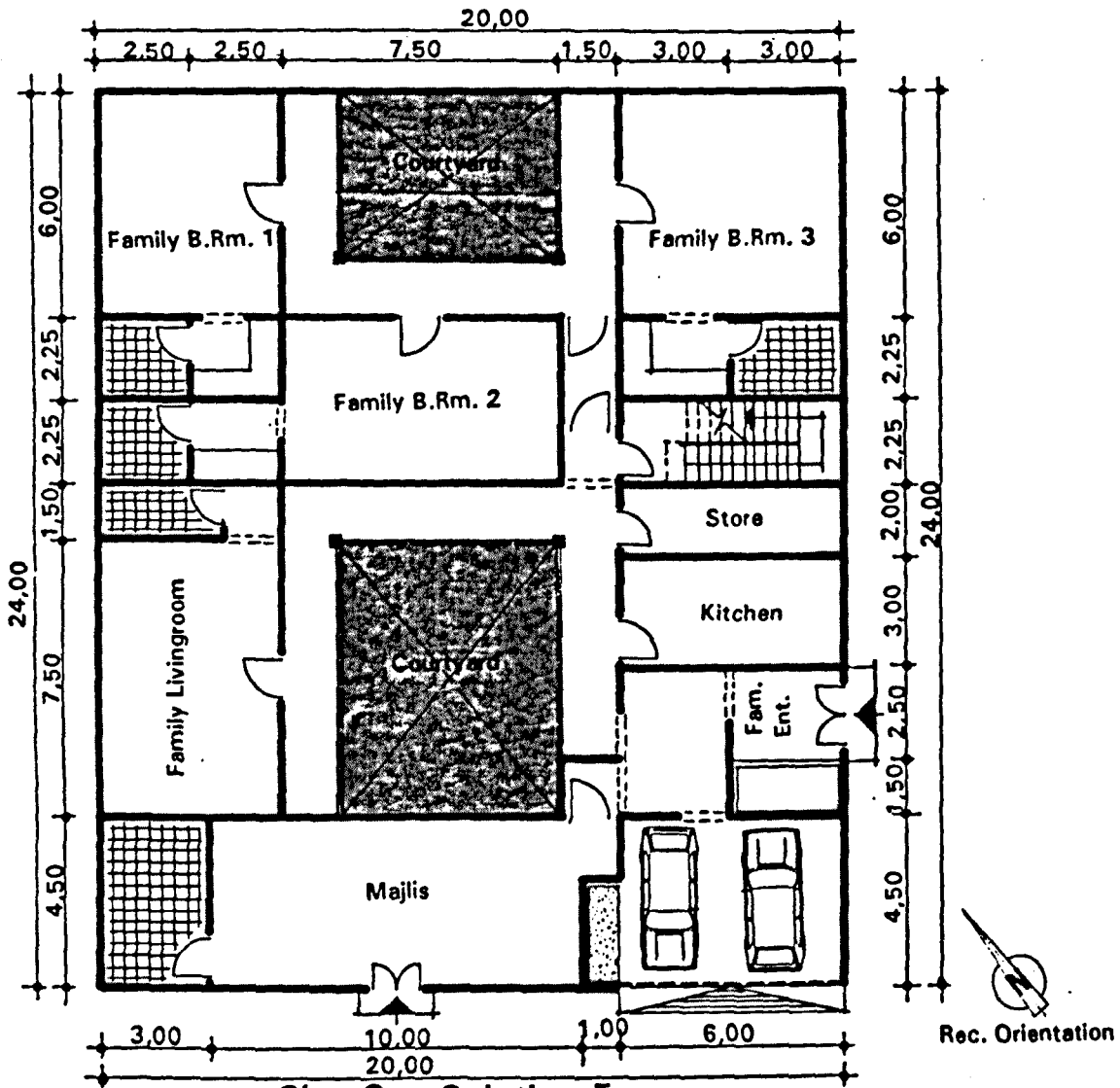

Fig 19 : Size C Solution 5
Scale 1:200

Size C - Solution 5

a The courtyards are of rectangular shapes, where one of the courtyards allows a skimming air flow regime and the other does not.

b Kitchen allows bad smells to be carried away to the house buildings.

c The built-up surface area = 296.25 m^2

Plot surface area = 480.00 m^2

Ratio of built-up surface area to plot surface area is:

$$296.25 / 480.00 = 61.72 \%$$

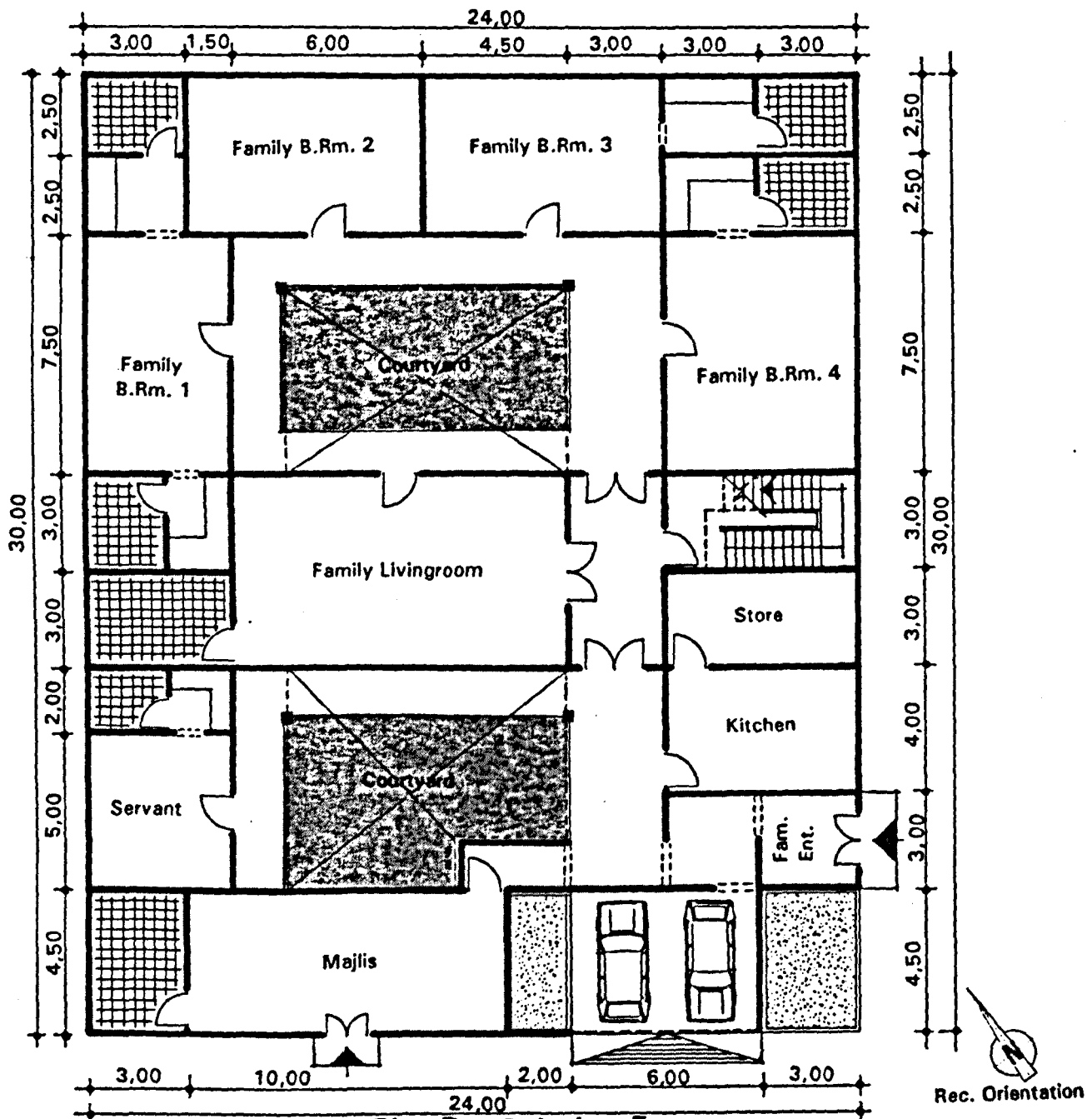

Fig 20 : Size D Solution 5
Scale 1:200

Size D - Solution 5

a The courtyards are of rectangular shapes, where both courtyards allow a skimming air flow regime.

b Kitchen allows bad smells to be carried away to the house buildings.

c The built-up surface area = 447.75 m^2

Plot surface area = 720.00 m^2

Ratio of built-up surface area to plot surface area is:

$$447.75 / 720.00 = 62.18 \%$$

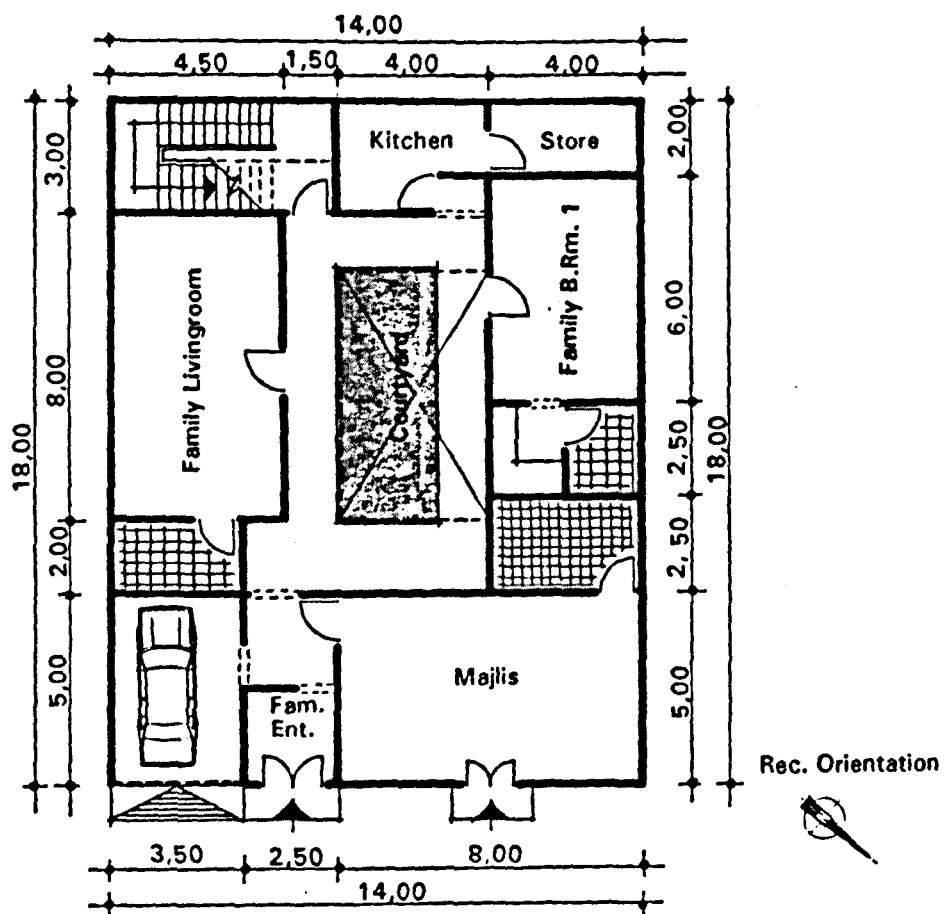

Fig 21 : Size A Solution 6
Scale 1:200

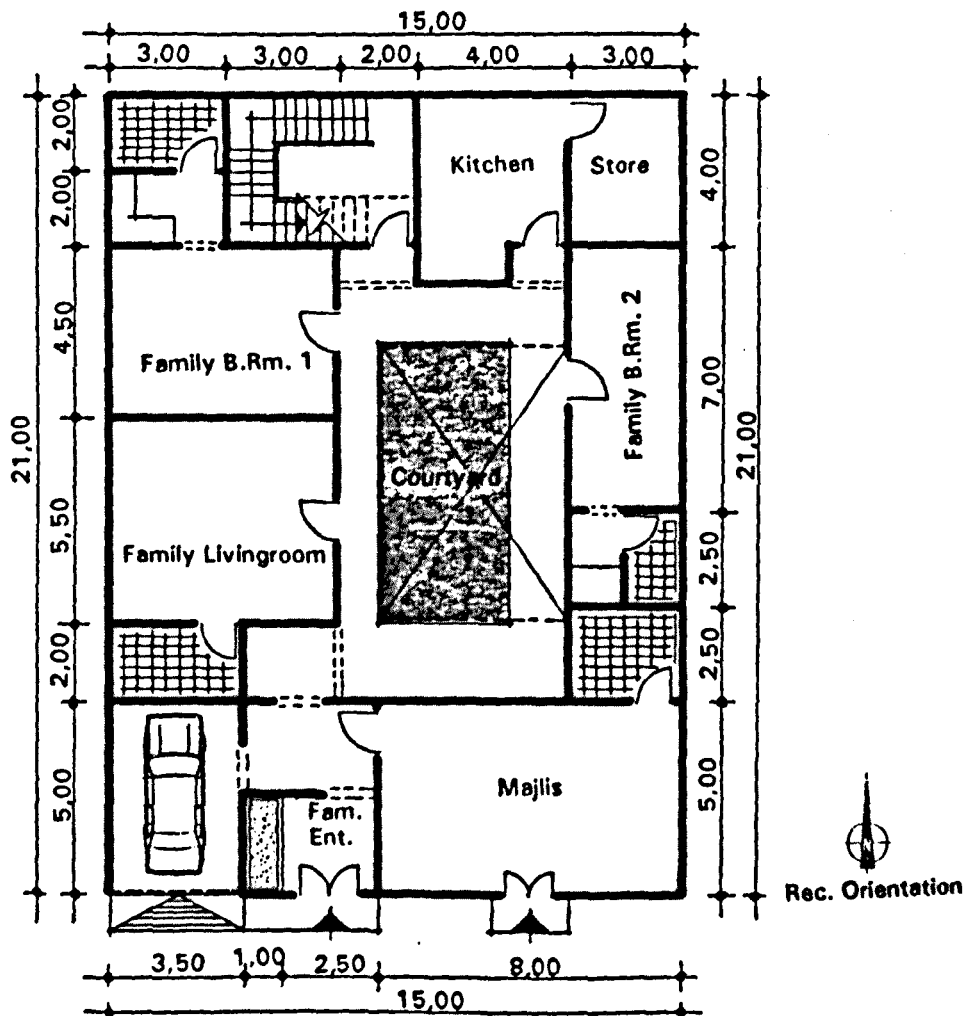

Fig 22 : Size B Solution 6
Scale 1:200

Size A - Solution 6

a The courtyard is of a rectangular shape which allows skimming air flow regime.

b Kitchen does not allow bad smells to be carried away to the house buildings.

c The built-up surface area = 164.50 m^2

Plot surface area = 252.00 m^2

Ratio of built-up surface area to plot surface area is:

$$164.50 / 252.00 = 65.27 \%$$

Size B - Solution 6

a The courtyard is of a rectangular shape which allows skimming air flow regime.

b Kitchen does not allow bad smells to be carried away to the house buildings.

c The built-up surface area = 204.50 m^2

Plot surface area = 315.00 m^2

Ratio of built-up surface area to plot surface area is:

$$204.50 / 315.00 = 64.92 \%$$

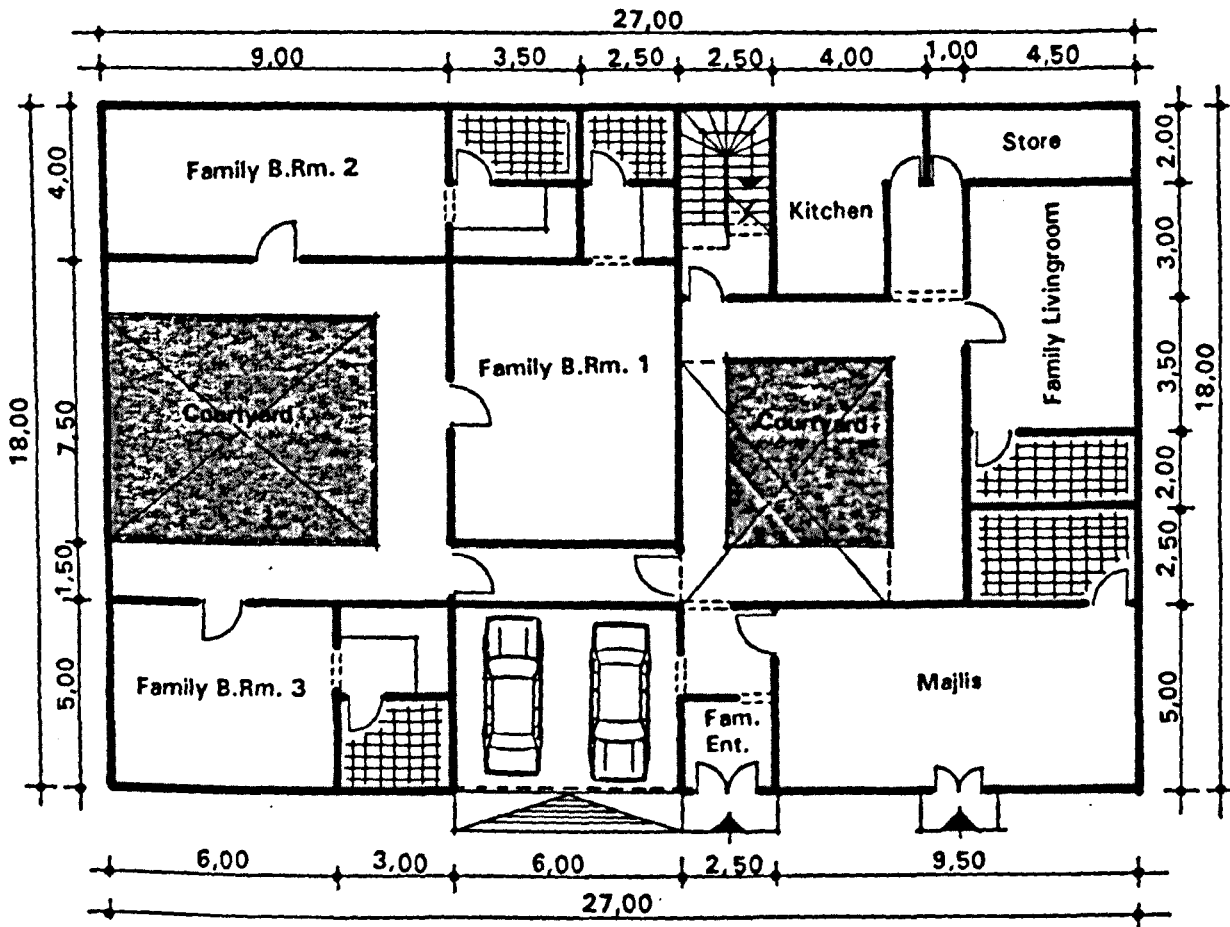

Fig 23 : Size C Solution 6
Scale 1:200



Size C - Solution 6

a The courtyards are of rectangular shapes, where both courtyards allow a skimming air flow regime.

b Kitchen does not allow bad smells to be carried away to the house buildings.

c The built-up surface area = 308.00 m²

Plot surface area = 486.00 m²

Ratio of built-up surface area to plot surface area is:

$$308.00 / 486.00 = 63.37 \%$$

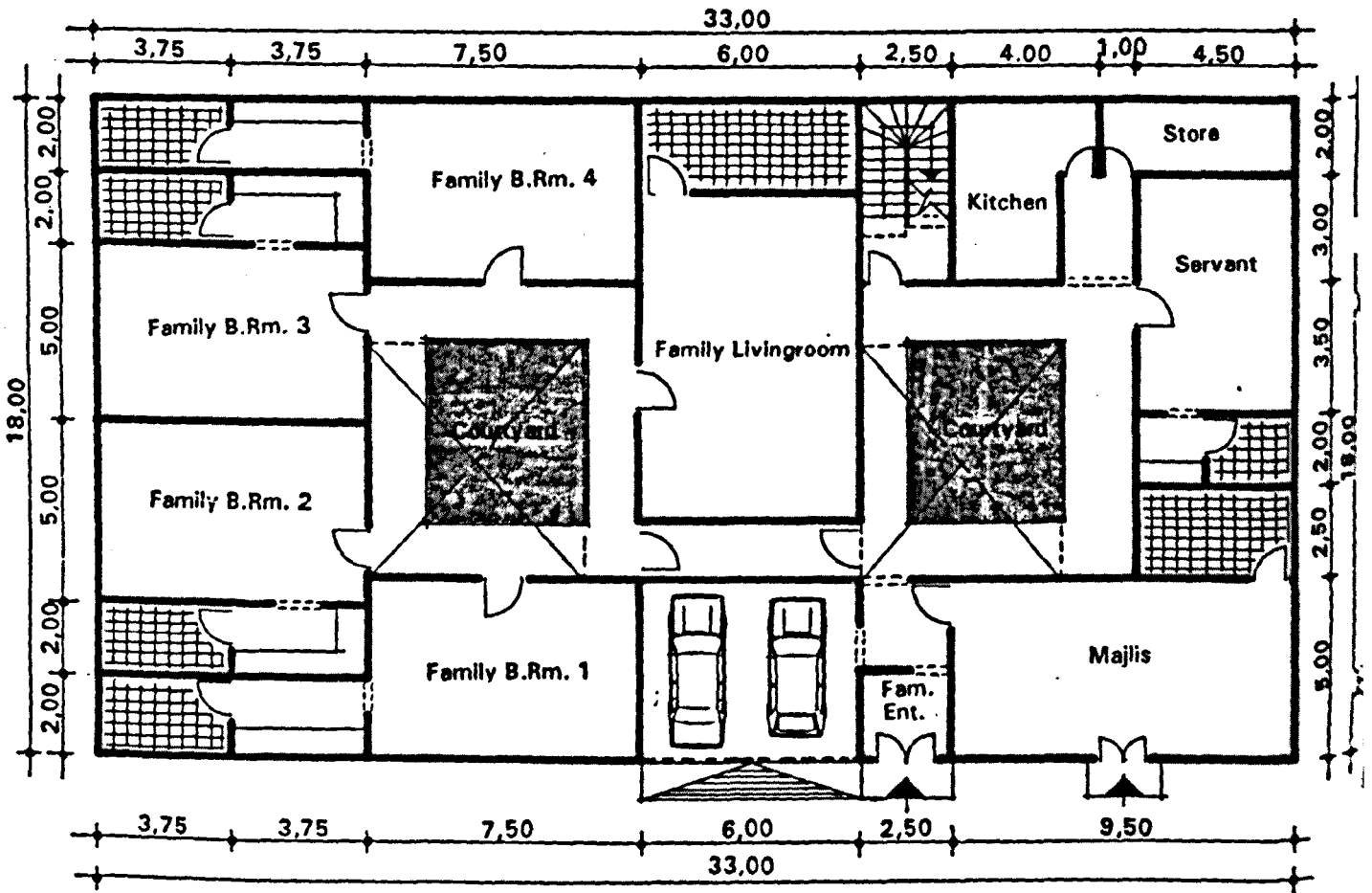

Fig 24 : Size D Solution 6
Scale 1:200



Size D - Solution 6

a The courtyards are of rectangular shapes, where both courtyards allow a skimming air flow regime.

b Kitchen does not allow bad smells to be carried away to the house buildings.

c The built-up surface area = 437.00 m²

Plot surface area = 594.00 m²

Ratio of built-up surface area to plot surface area is:

$$437.00 / 594.00 = 73.56 \%$$

SIZE	Recommended Built-up Surface area	Yard- stick	SOLUTION					
			1	2	3	4	5	6
A	141 m ²	a	3	4	3	4	1	3
		b	0	0	0	0	-	0
		c	165.05	161.60	175.00	177.90	-----	164.50
B	200 m ²	a	3	4	3	4	3	3
		b	0	0	0	0	X	0
		c	256.50	215.50	224.00	203.25	-----	204.50
C	264 m ²	a	4	3	3	4	2	3
		b	0	0	0	0	-	0
		c	273.50	308.50	298.50	303.75	-----	308.00
D	341 m ²	a	4	4	4	4	3	4
		b	0	0	0	0	X	0
		c	444.25	439.00	402.75	410.00	-----	437.00

Thus successful design solution of type I are:

Size A solution 2

Size B solution 4

Size C solution 1

Size D solution 3

Proposed elevations of the selected design solutions of the dwelling units type I are shown in figures 25, 26, 27 and 28.

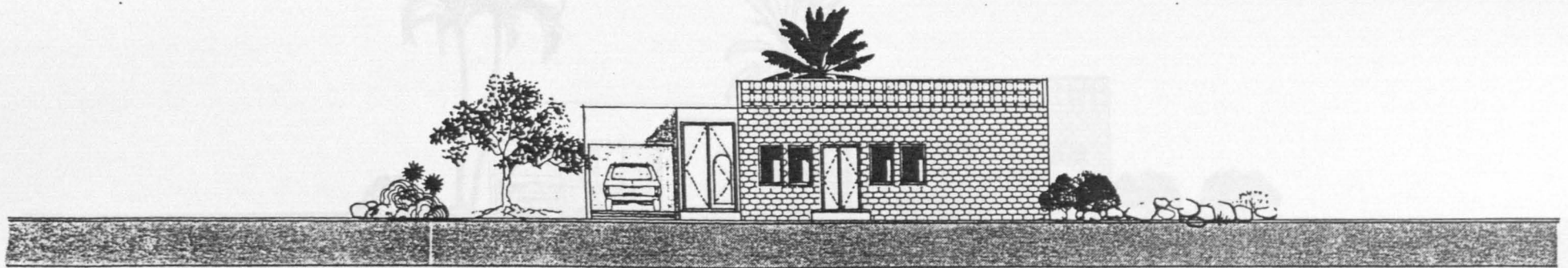

Fig 25 : Size A Solution 2
Front Elevation
Scale 1:200

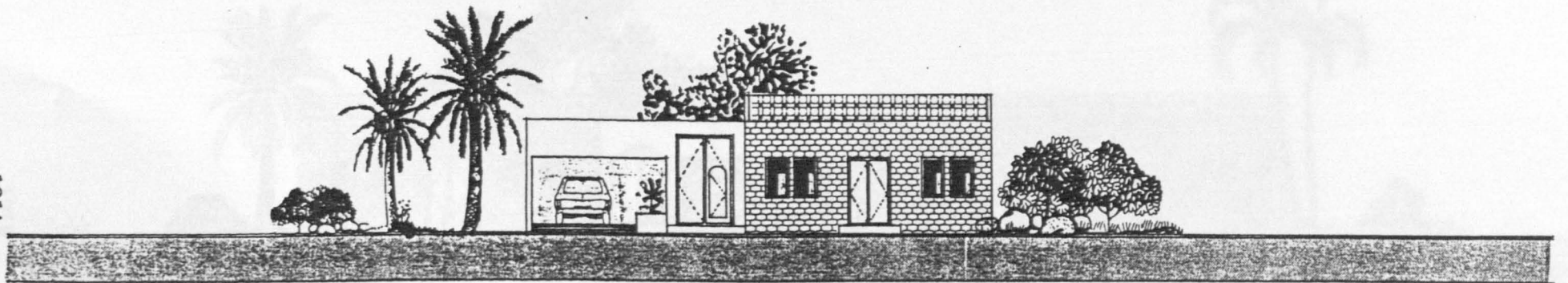

Fig 26 : Size B Solution 4
Front Elevation
Scale 1:200

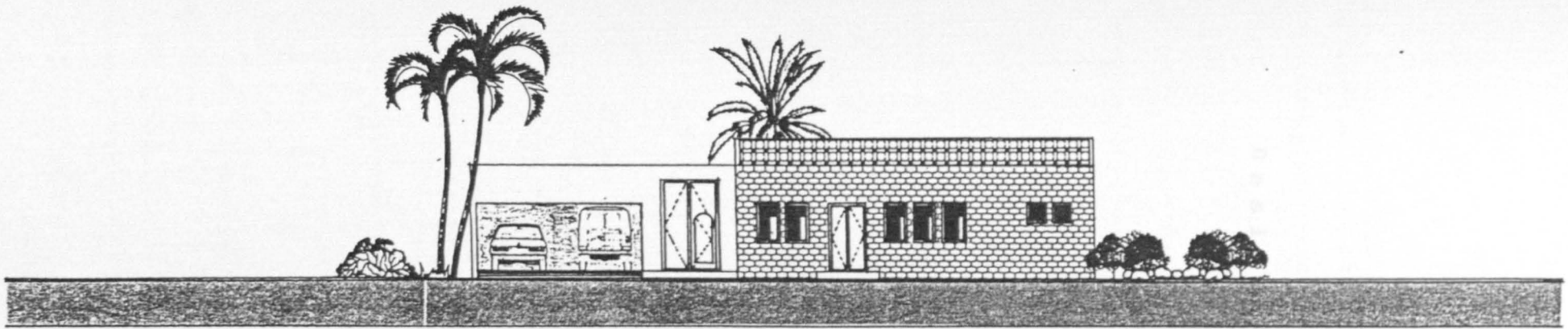

Fig 27 : Size C Solution 1
Front Elevation
Scale 1:200

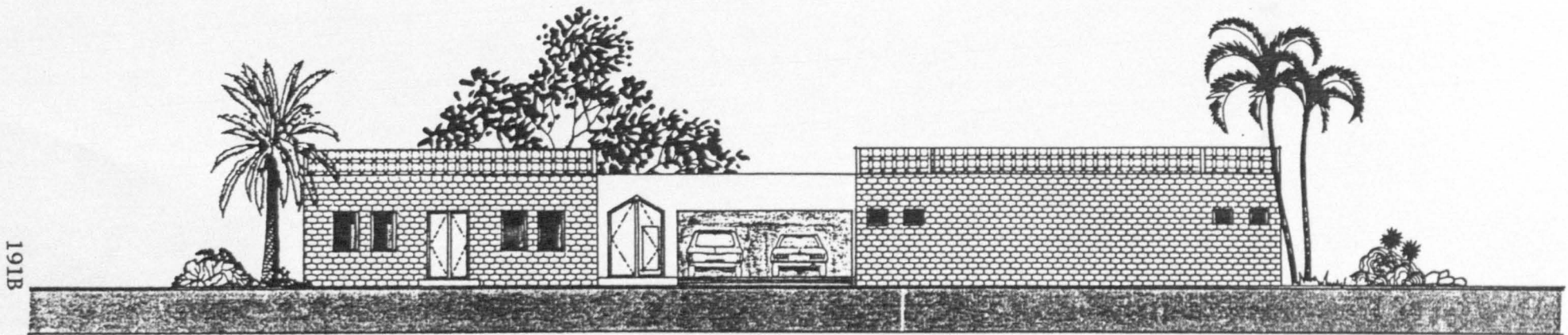

Fig 28 : Size D Solution 3
Front Elevation
Scale 1:200

191B

D e s i g n S o l u t i o n s T y p e I I

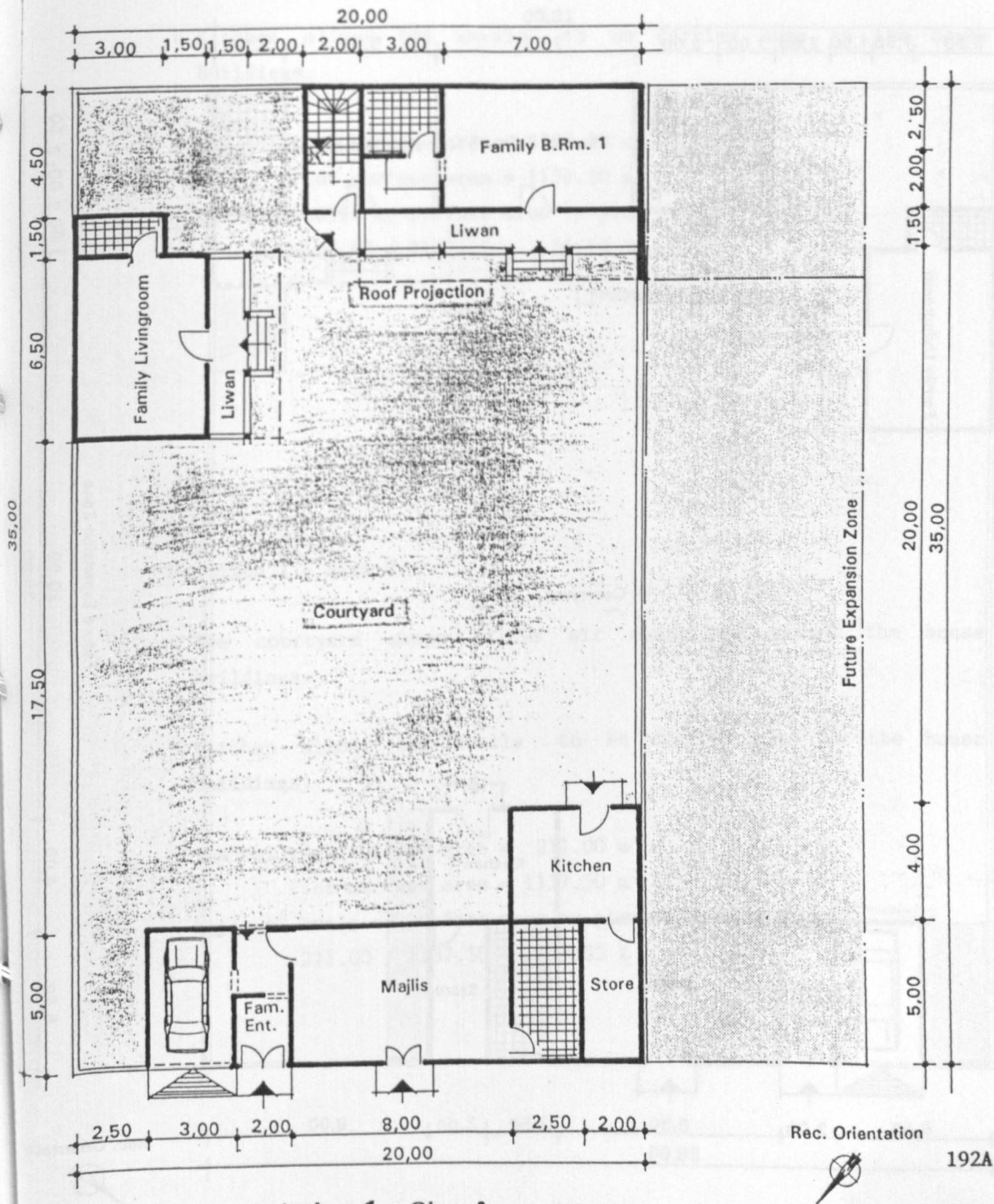
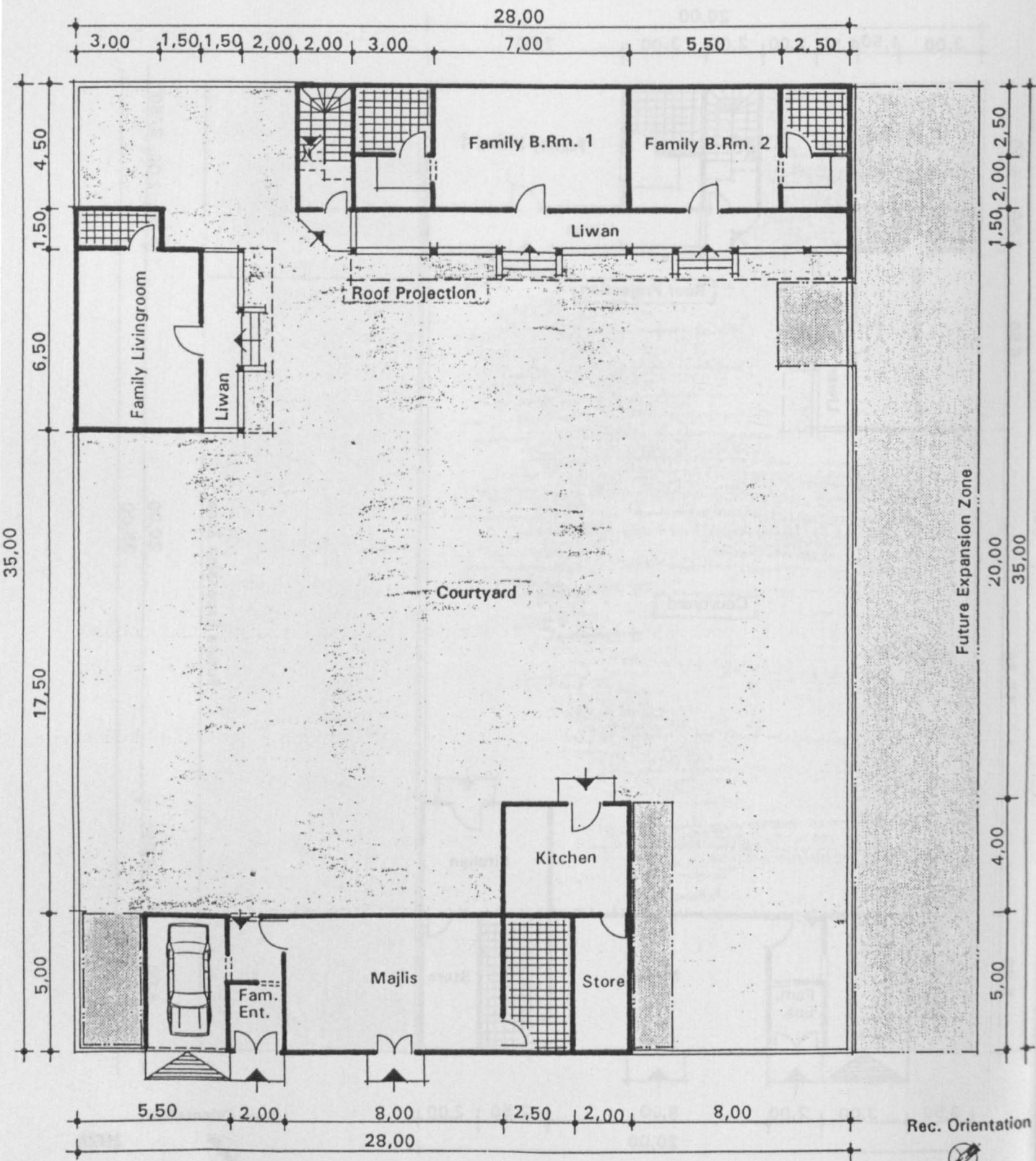

Fig 29 : Solution 1 Size A
 Scale 1:200



193A

Fig 30 : Solution 1 Size B

Scale 1:200

Rec. Orientation



Solution 1 - Size A

a The courtyard shape allows air channelling around the house buildings.

b Kitchen allows bad smells to be carried away to the house buildings.

c The built-up surface area = 160.00 m²

Plot surface area = 1137.50 m²

Ratio of built-up surface area to plot surface area is:

$$160.00 / 1137.50 = 14.10 \%$$

Solution 1 - Size B

a The courtyard shape allows air channelling around the house buildings.

b Kitchen allows bad smells to be carried away to the house buildings.

c The built-up surface area = 211.00 m²

Plot surface area = 1137.50 m²

Ratio of built-up surface area to plot surface area is:

$$211.00 / 1137.50 = 18.55 \%$$

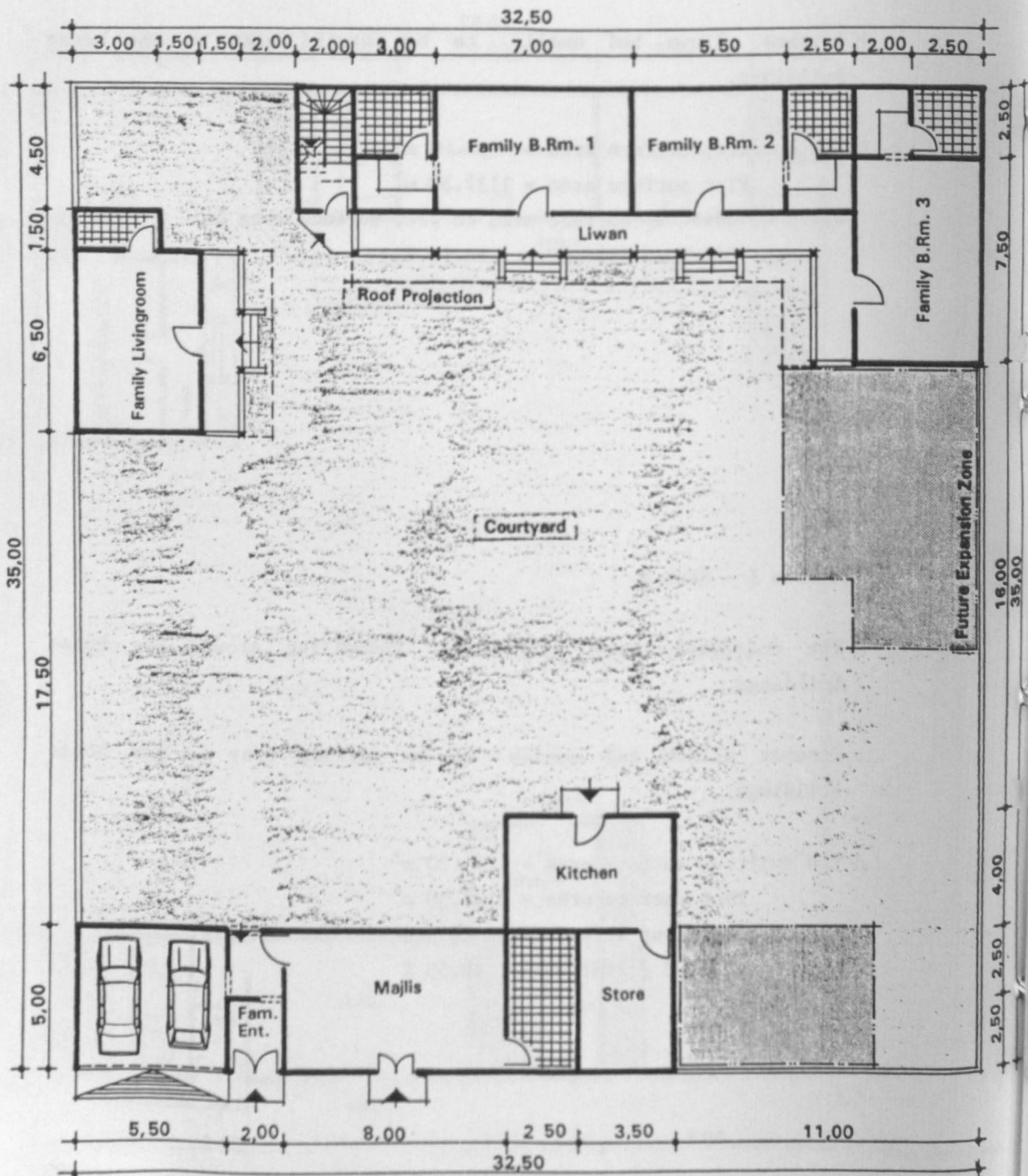

194A

Fig 31 : Solution 1 Size C
Scale 1:200

Rec. Orientation



Solution 1 - Size C

a The courtyard shape allows air channelling around the house buildings.

b Kitchen allows bad smells to be carried away to the house buildings.

c The built-up surface area = 268.50 m²

Plot surface area = 1137.50 m²

Ratio of built-up surface area to plot surface area is:

$$268.50 / 1137.50 = 23.60 \%$$

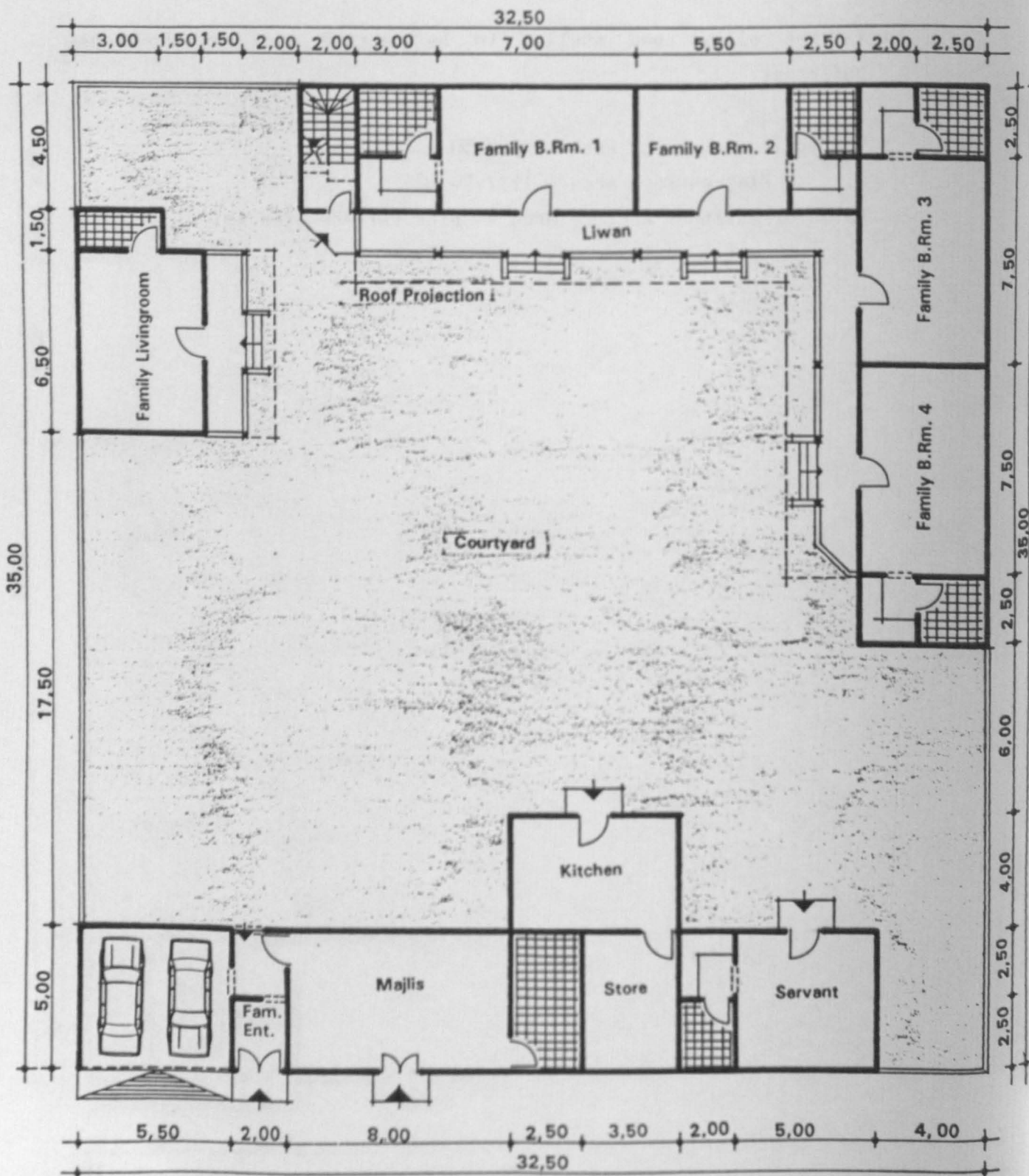

195A

Fig 32 : Solution 1 Size D

Scale 1:200

Rec. Orientation



Solution 1 - Size D

a The courtyard shape allows air channelling around the house buildings.

b Kitchen allows bad smells to be carried away to the house buildings.

c The built-up surface area = 362.00 m^2

Plot surface area = 1137.50 m^2

Ratio of built-up surface area to plot surface area is:

$$362.00 / 1137.50 = 31.82 \%$$

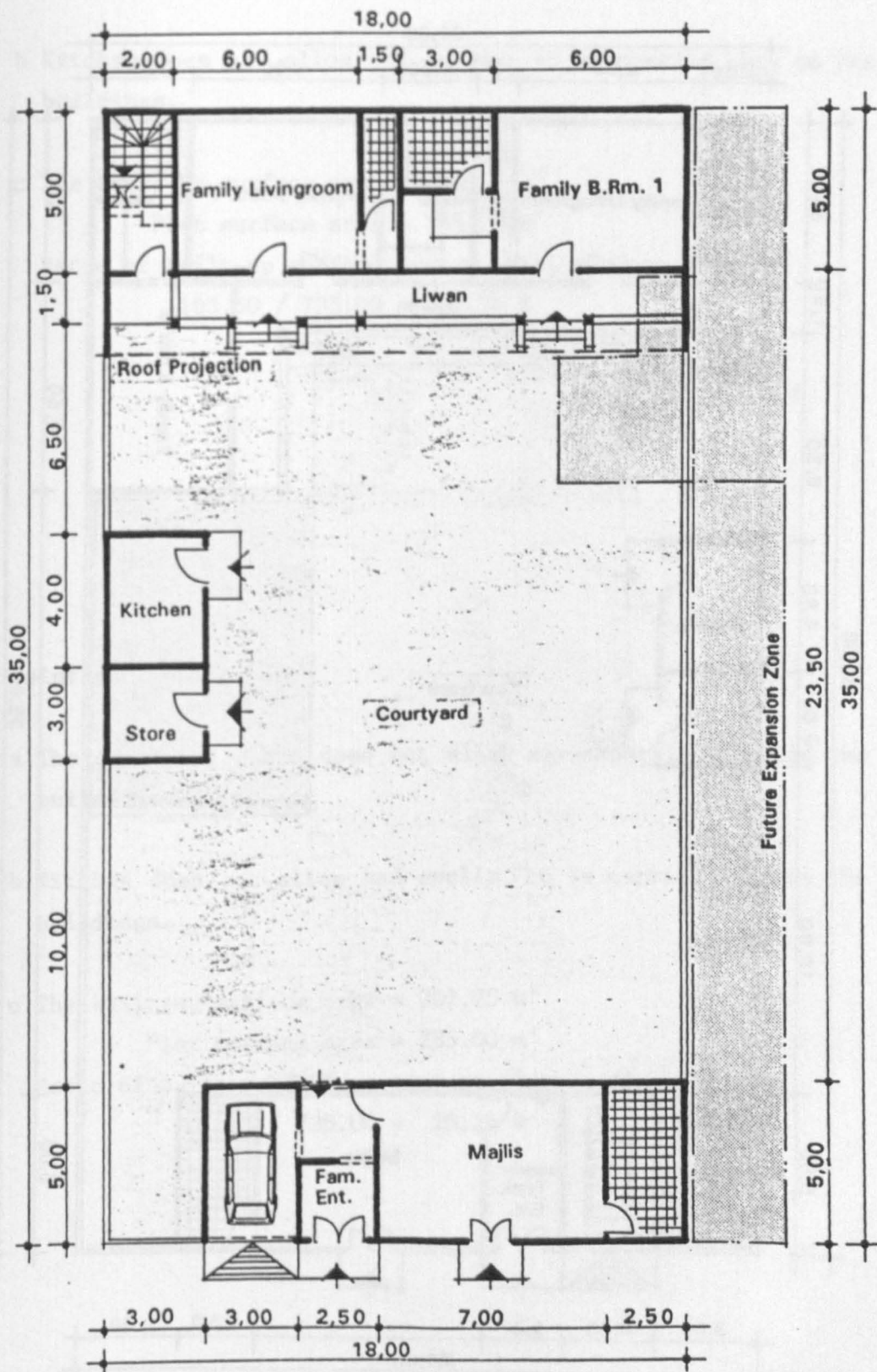

Fig 33 : Solution 2 Size A
Scale 1:200

Rec. Orientation



195B

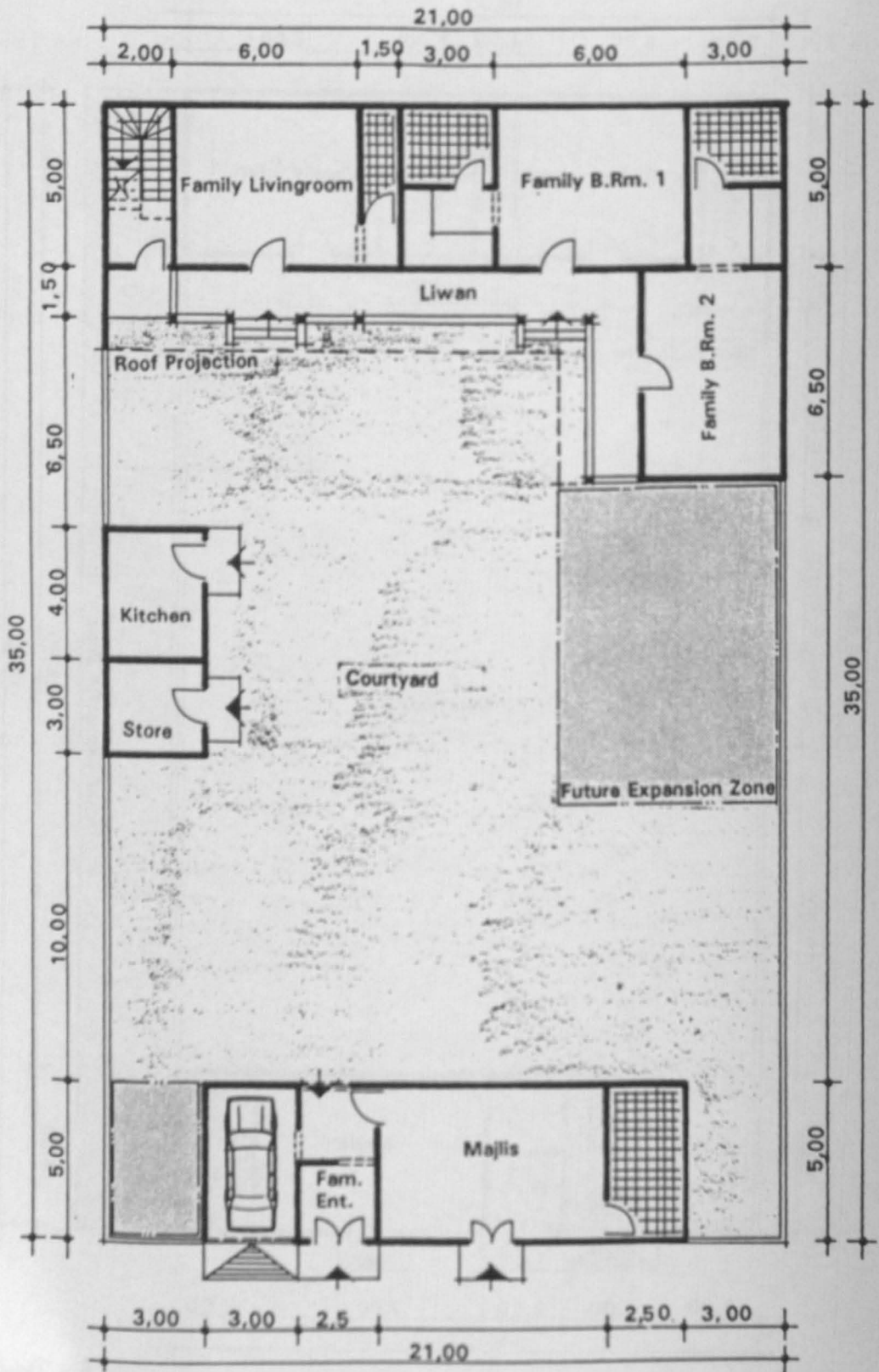

Fig 34 : Solution 2 Size B

Scale 1:200



Solution 2 - Size A

- a The courtyard shape does not allow air channelling around the house buildings.
- b Kitchen does not allow bad smells to be carried away to the house buildings.
- c The built-up surface area = 163.50 m^2
Plot surface area = 735.00 m^2
Ratio of built-up surface area to plot surface area is:
 $163.50 / 735.00 = 22.24 \%$

Solution 2 - Size B

- a The courtyard shape does not allow air channelling around the house buildings.
- b Kitchen does not allow bad smells to be carried away to the house buildings.
- c The built-up surface area = 207.75 m^2
Plot surface area = 735.00 m^2
Ratio of built-up surface area to plot surface area is:
 $207.75 / 735.00 = 28.26 \%$

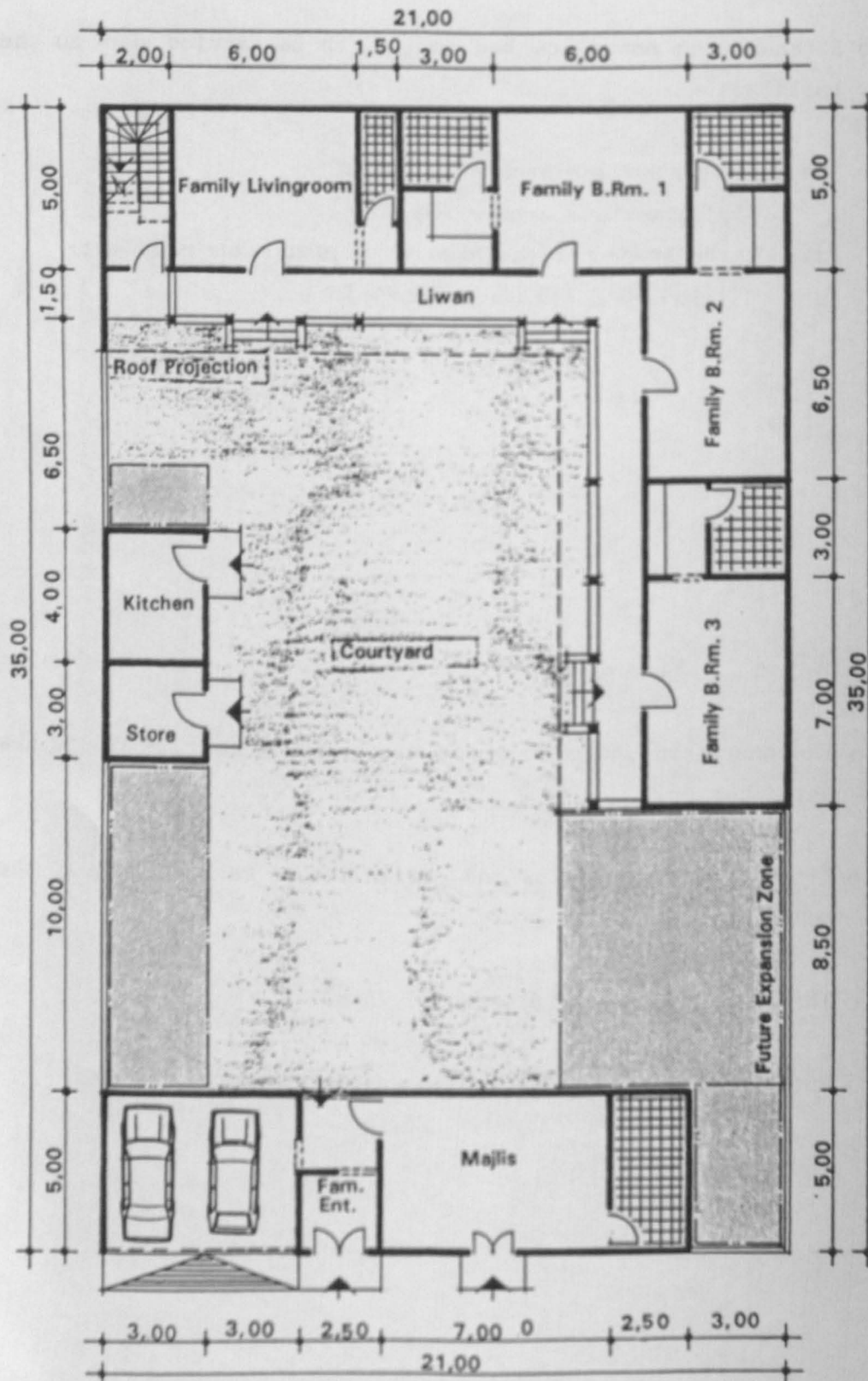

Fig 35 : Solution 2 Size C

Scale 1:200



Solution 2 - Size C

a The courtyard shape does not allow air channelling around the house buildings.

b Kitchen does not allow bad smells to be carried away to the house buildings.

c The built-up surface area = 267.75 m²

Plot surface area = 735.00 m²

Ratio of built-up surface area to plot surface area is:

$$267.75 / 735.00 = 36.42 \%$$

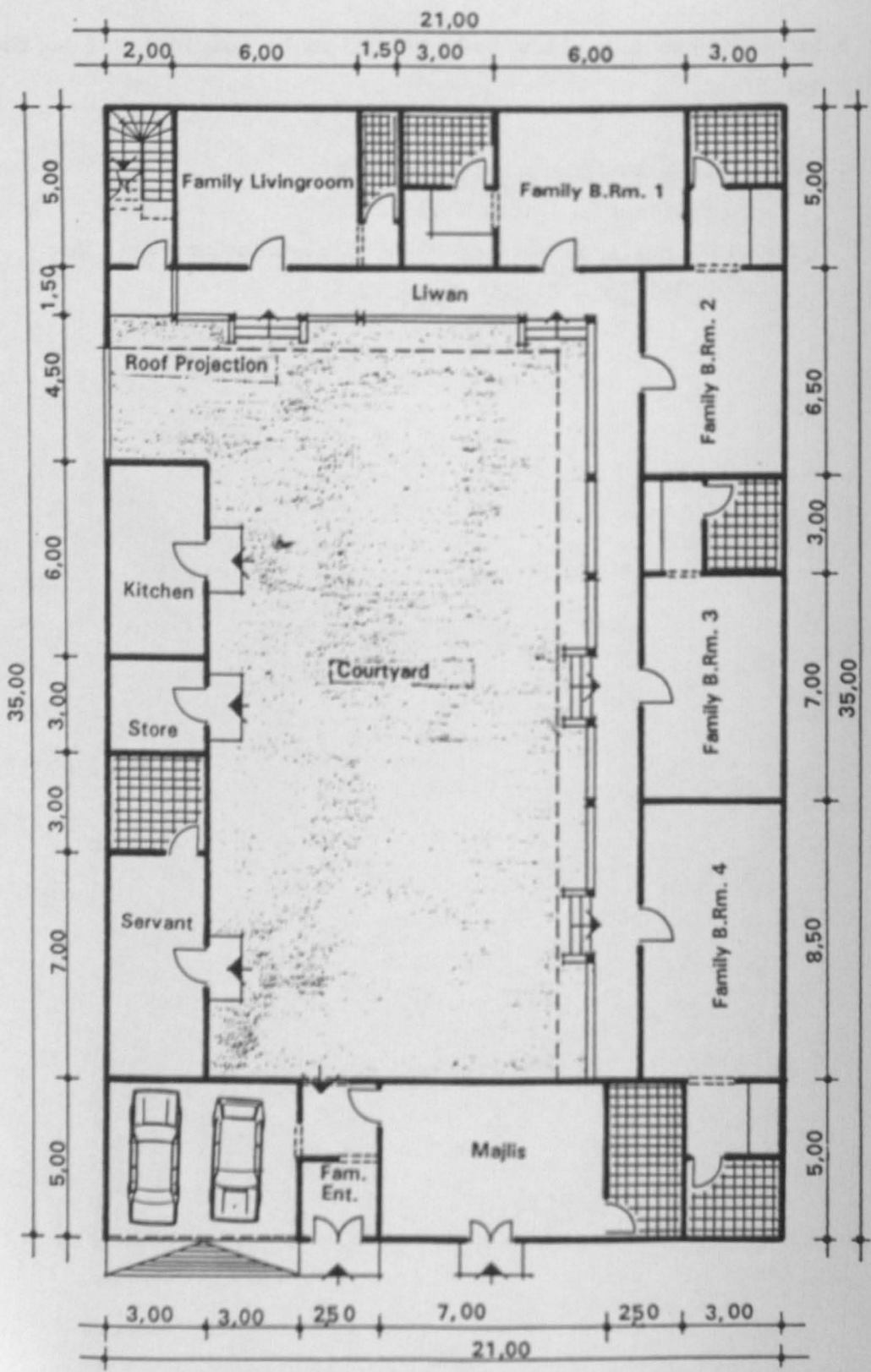

Fig 36 : Solution 2 Size D
Scale 1:200

Rec. Orientation



Solution 2 - Size D

a The courtyard shape does not allow air channelling around the house buildings.

b Kitchen does not allow bad smells to be carried away to the house buildings.

c The built-up surface area = 357.00 m²

Plot surface area = 735.00 m²

Ratio of built-up surface area to plot surface area is:

$$357.00 / 735.00 = 48.57 \%$$

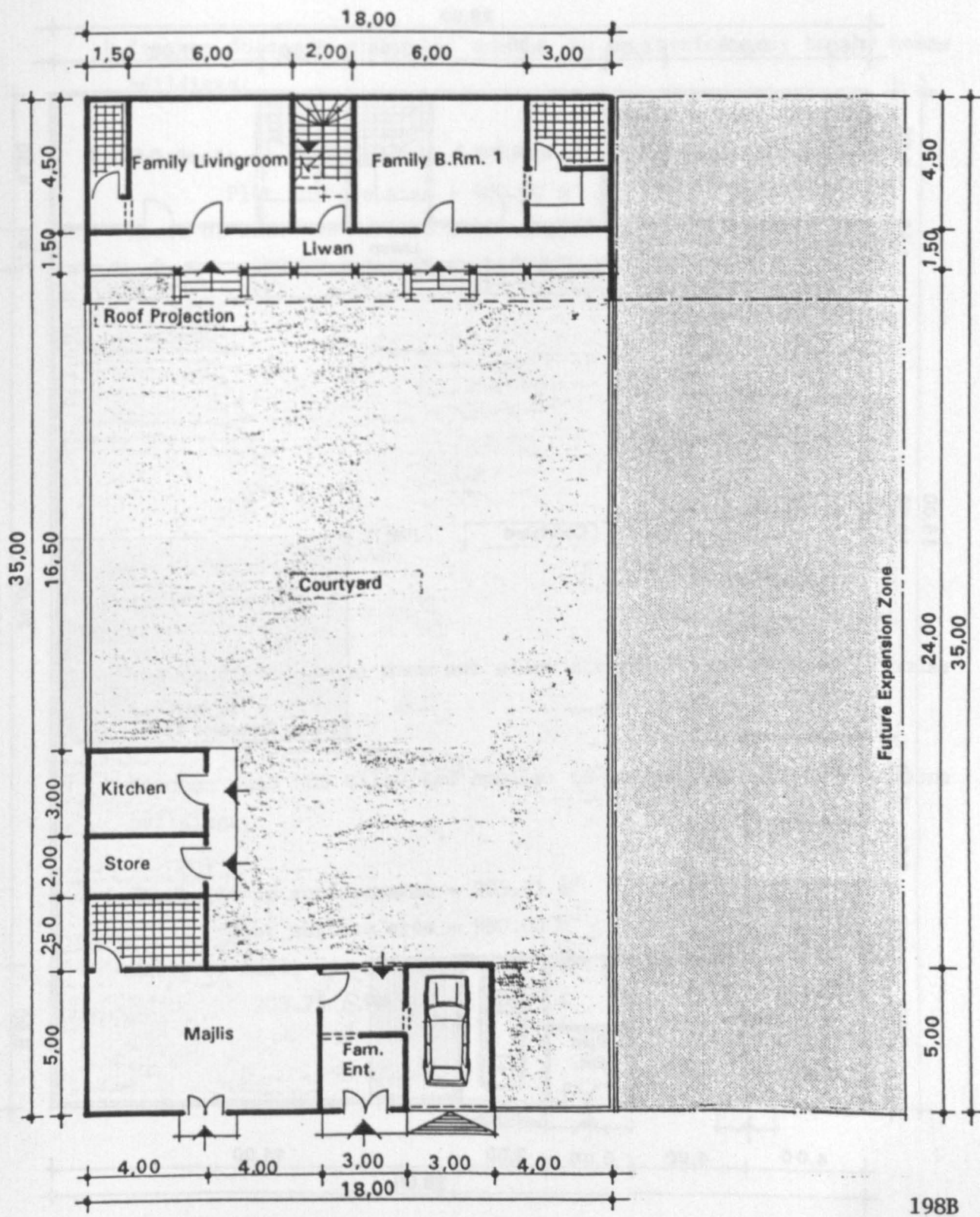

198B

Fig 37 : Solution 3 Size A
Scale 1:200



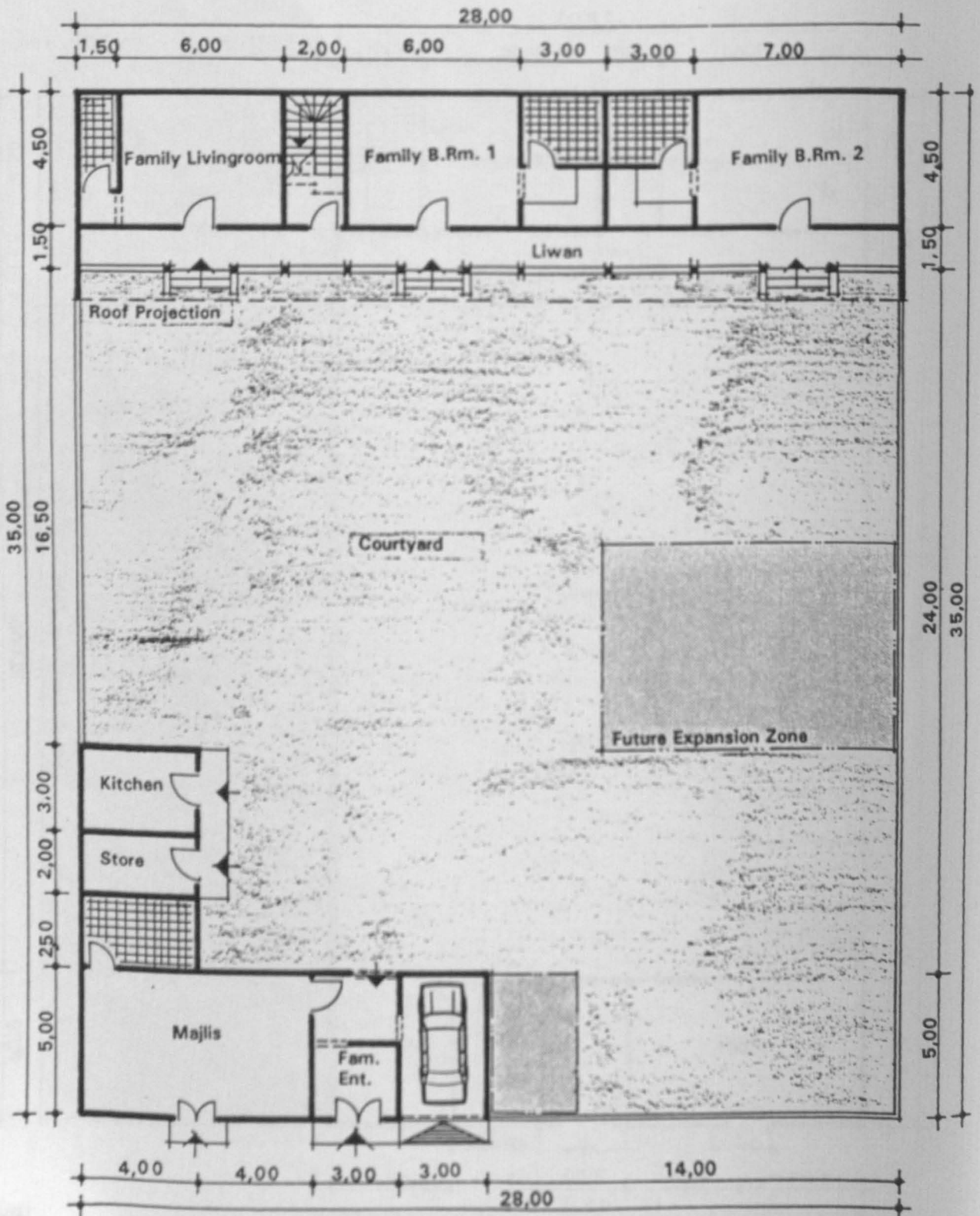

Solution 3 - Size A

a The courtyard shape does not allow air channelling around the house buildings.

b Kitchen does not allow bad smells to be carried away to the house buildings.

c The built-up surface area = 160.75 m²

Plot surface area = 980.00 m²

Ratio of built-up surface area to plot surface area is:

$$160.75 / 980.00 = 16.40 \%$$

Solution 3 - Size B

a The courtyard shape does not allow air channelling around the house buildings.

b Kitchen does not allow bad smells to be carried away to the house buildings.

c The built-up surface area = 205.75 m²

Plot surface area = 980.00 m²

Ratio of built-up surface area to plot surface area is:

$$205.75 / 980.00 = 20.99 \%$$

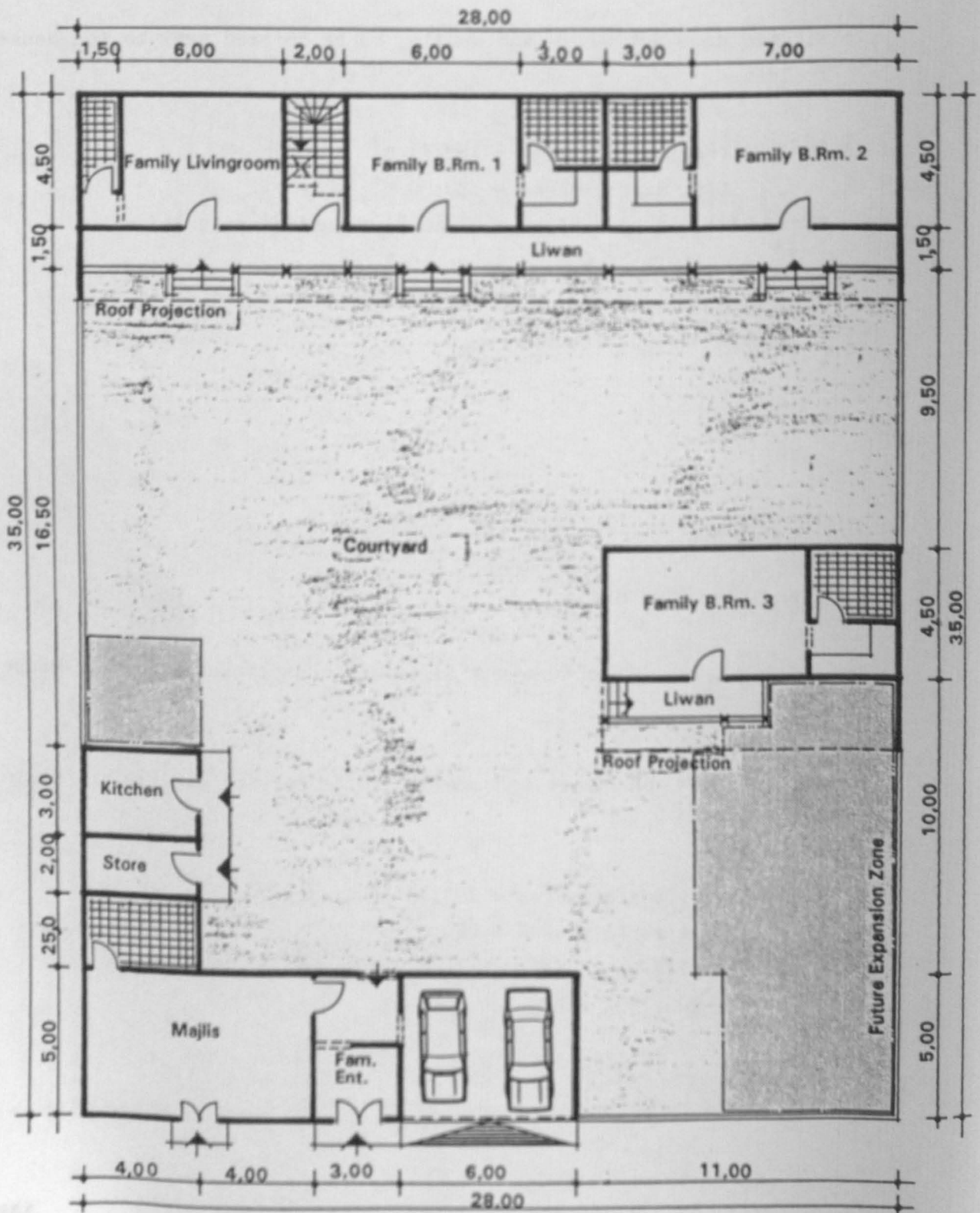
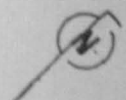

Fig 39 : Solution 3 Size C

Scale 1:200

Rec. Orientation



Solution 3 - Size C

a The courtyard shape allows air channelling around the house buildings.

b Kitchen does not allow bad smells to be carried away to the house buildings.

c The built-up surface area = 265.75 m²

Plot surface area = 980.00 m²

Ratio of built-up surface area to plot surface area is:

$$265.75 / 980.00 = 27.12 \%$$

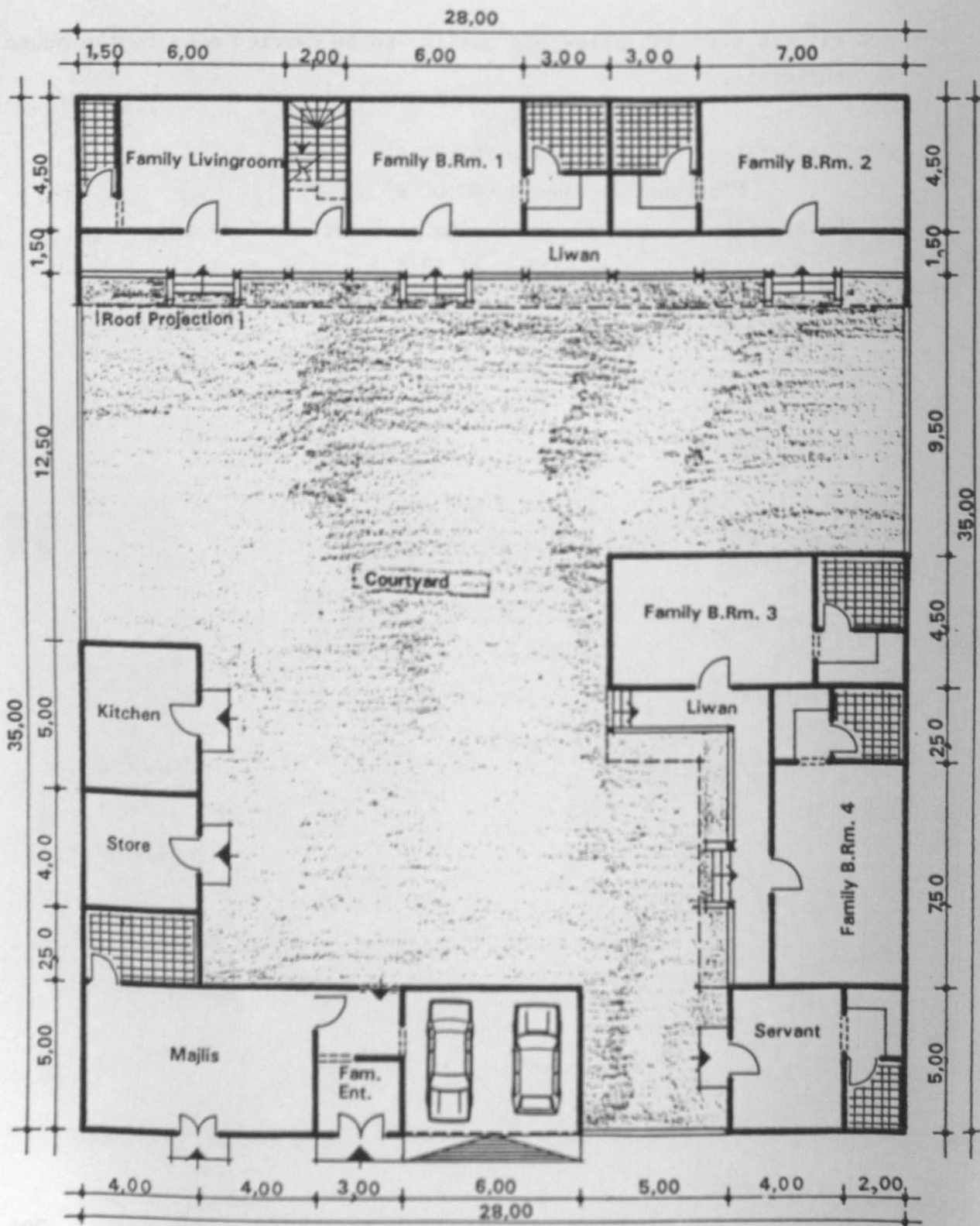

Fig 40 : Solution 3 Size D

Scale 1:200

Rec. Orientation



Solution 3 - Size D

a The courtyard shape allows air channelling around the house buildings.

b Kitchen does not allow bad smells to be carried away to the house buildings.

c The built-up surface area = 353.00 m²

Plot surface area = 980.00 m²

Ratio of built-up surface area to plot surface area is:

$$353.00 / 980.00 = 36.02 \%$$

The courtyard shape does not allow for classifying around the house buildings.

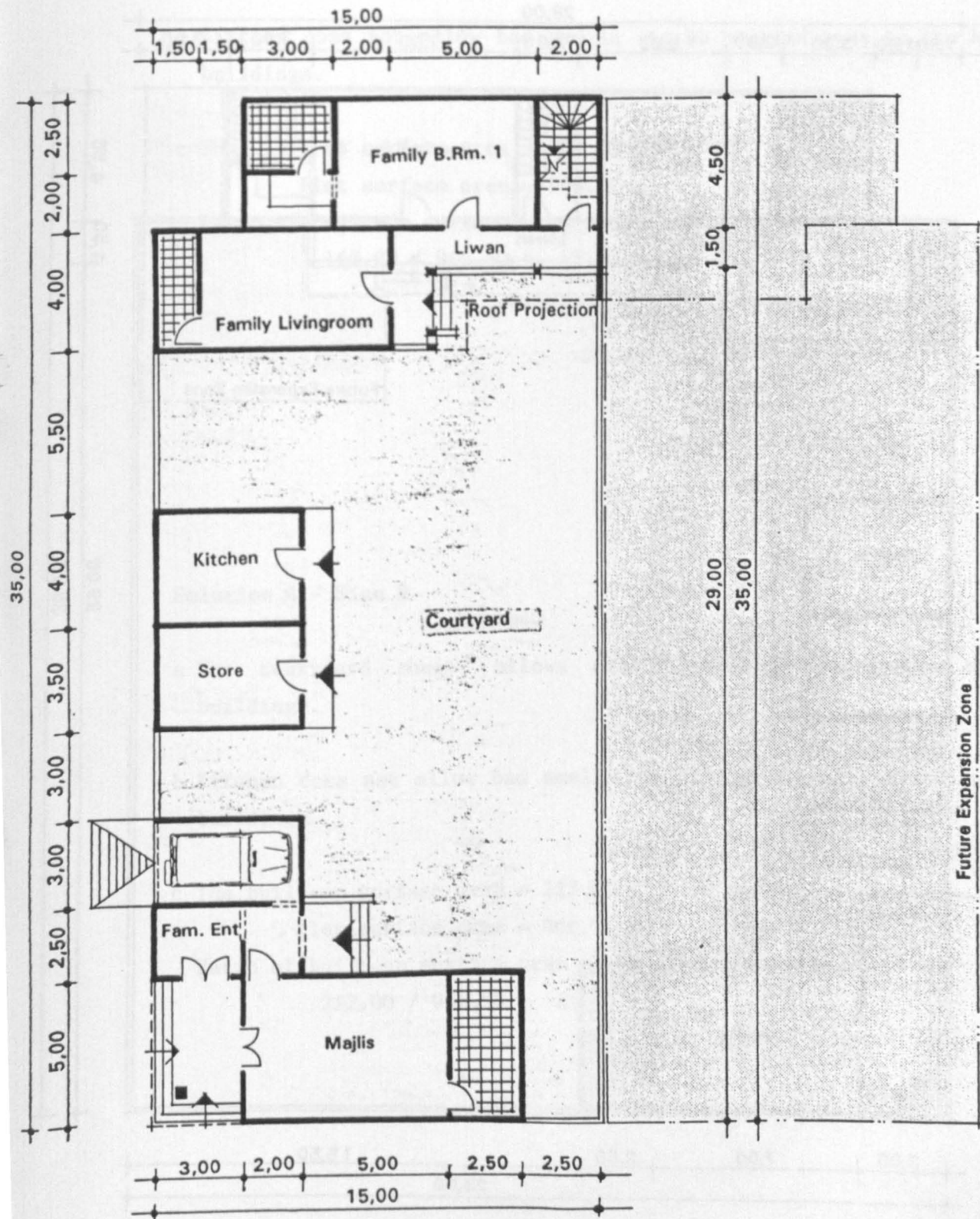
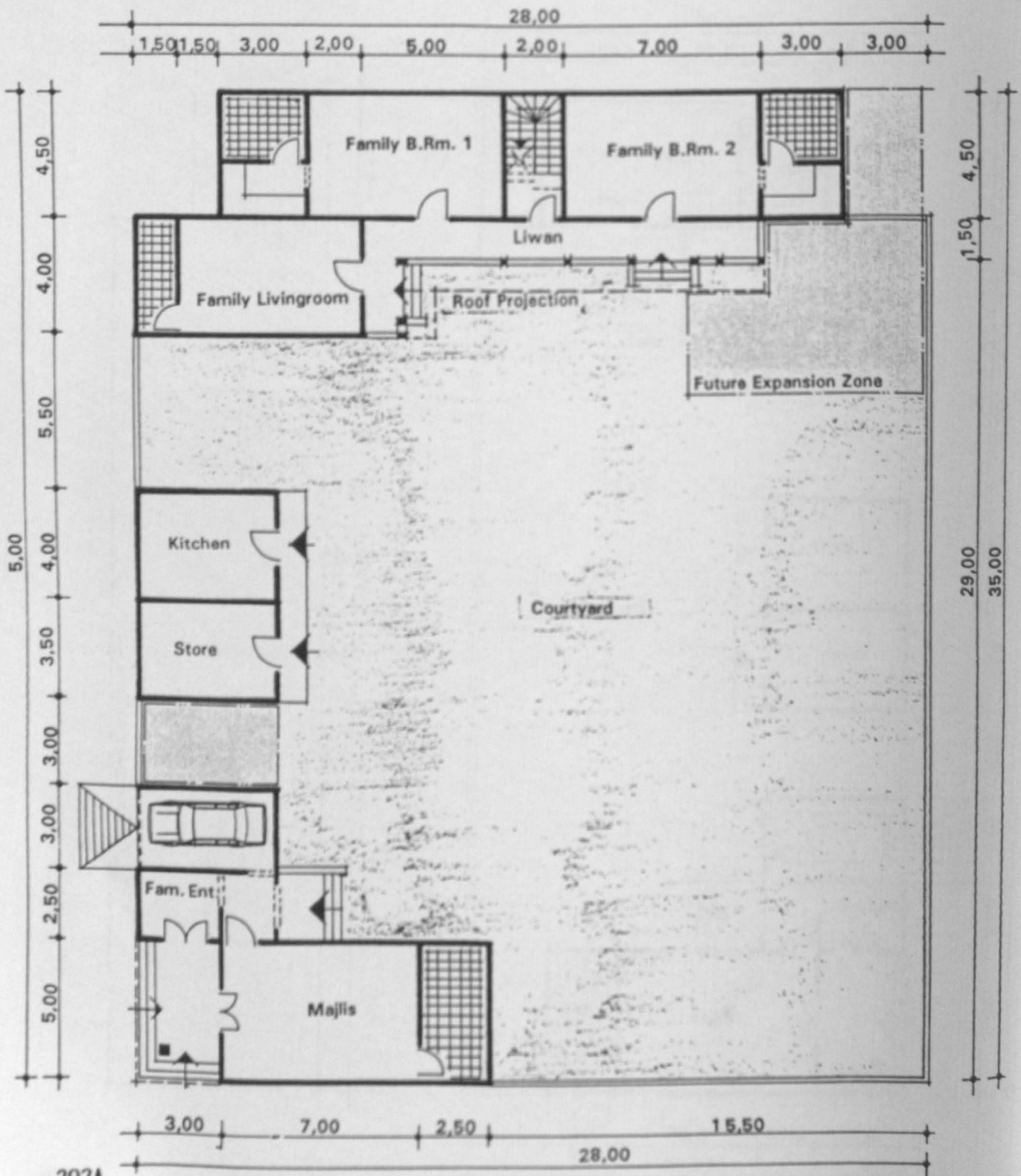

Fig 41 : Solution 4 Size A

Scale 1:200

Rec. Orientation





202A

Fig 42 : Solution 4 Size B
Scale 1:200

Rec. Orientation



Solution 4 - Size A

a The courtyard shape does not allow air channelling around the house buildings.

b Kitchen does not allow bad smells to be carried away to the house buildings.

c The built-up surface area = 167.00 m²

Plot surface area = 966.50 m²

Ratio of built-up surface area to plot surface area is:

$$167.00 / 966.50 = 17.27 \%$$

Solution 4 - Size B

a The courtyard shape allows air channelling around the house buildings.

b Kitchen does not allow bad smells to be carried away to the house buildings.

c The built-up surface area = 212.00 m²

Plot surface area = 966.50 m²

Ratio of built-up surface area to plot surface area is:

$$212.00 / 966.50 = 21.93 \%$$

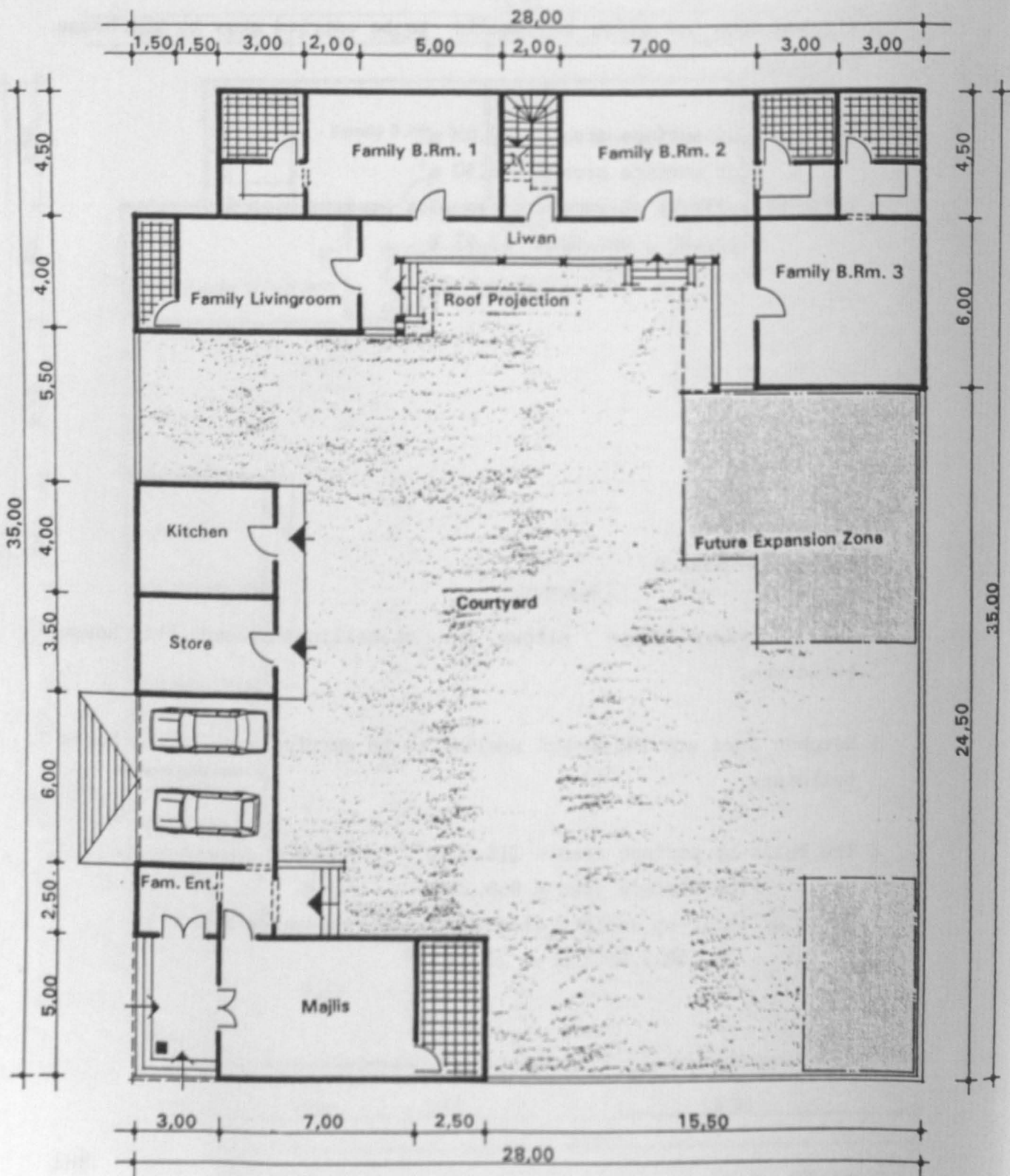

Fig 43 : Solution 4 Size C
Scale 1:200

Rec. Orientation



Solution 4 - Size C

a The courtyard shape allows air channelling around the house buildings.

b Kitchen does not allow bad smells to be carried away to the house buildings.

c The built-up surface area = 276.50 m²

Plot surface area = 966.50 m²

Ratio of built-up surface area to plot surface area is:

$$276.50 / 966.50 = 28.61 \%$$

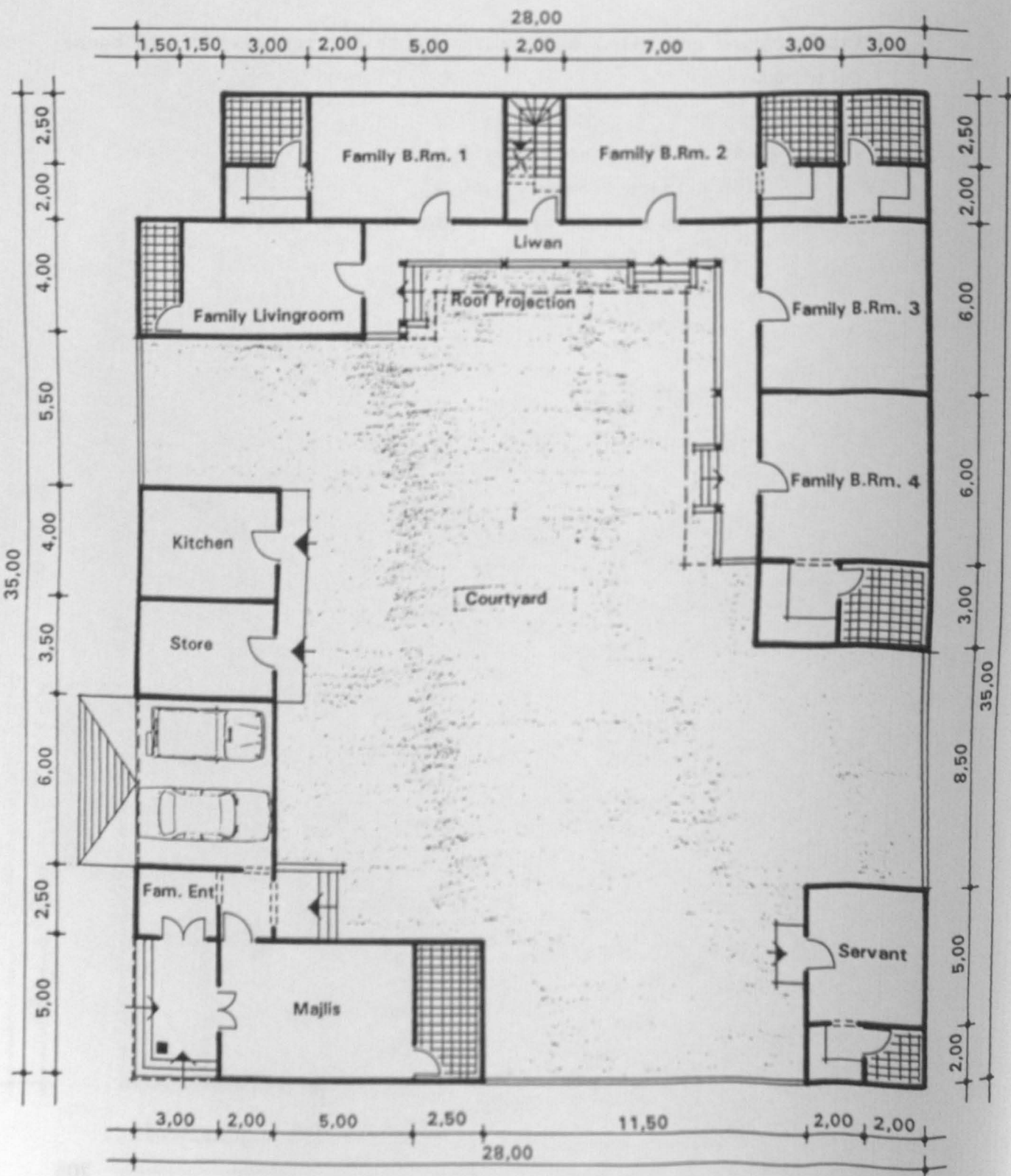
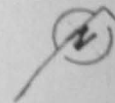

Fig 44 : Solution 4 Size D

Scale 1:200

Rec. Orientation



Solution 4 - Size D

a The courtyard shape allows air channelling around the house buildings.

b Kitchen does not allow bad smells to be carried away to the house buildings.

c The built-up surface area = 368.50 m²

Plot surface area = 966.50 m²

Ratio of built-up surface area to plot surface area is:

$$368.50 / 966.50 = 38.13 \%$$

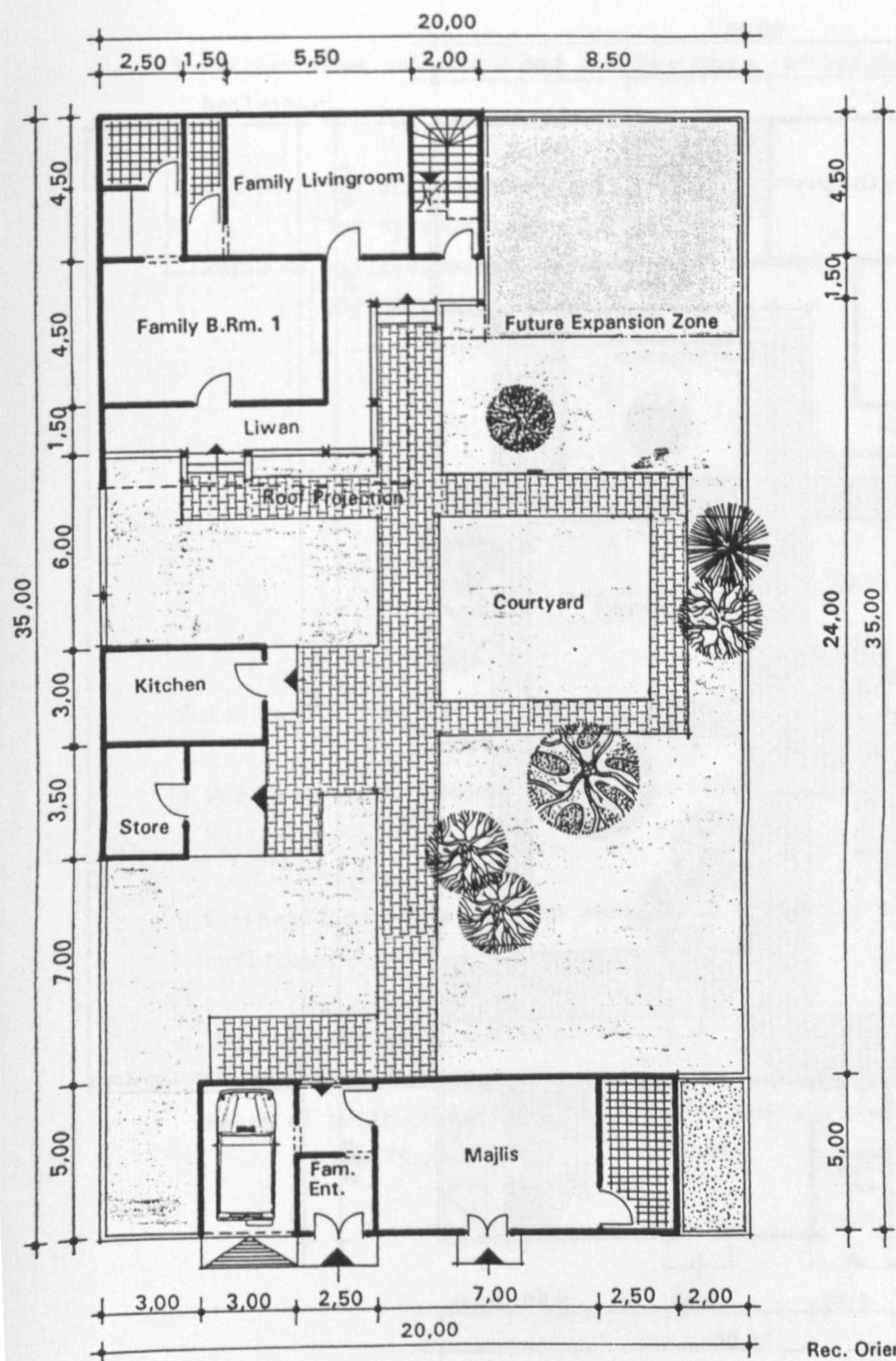
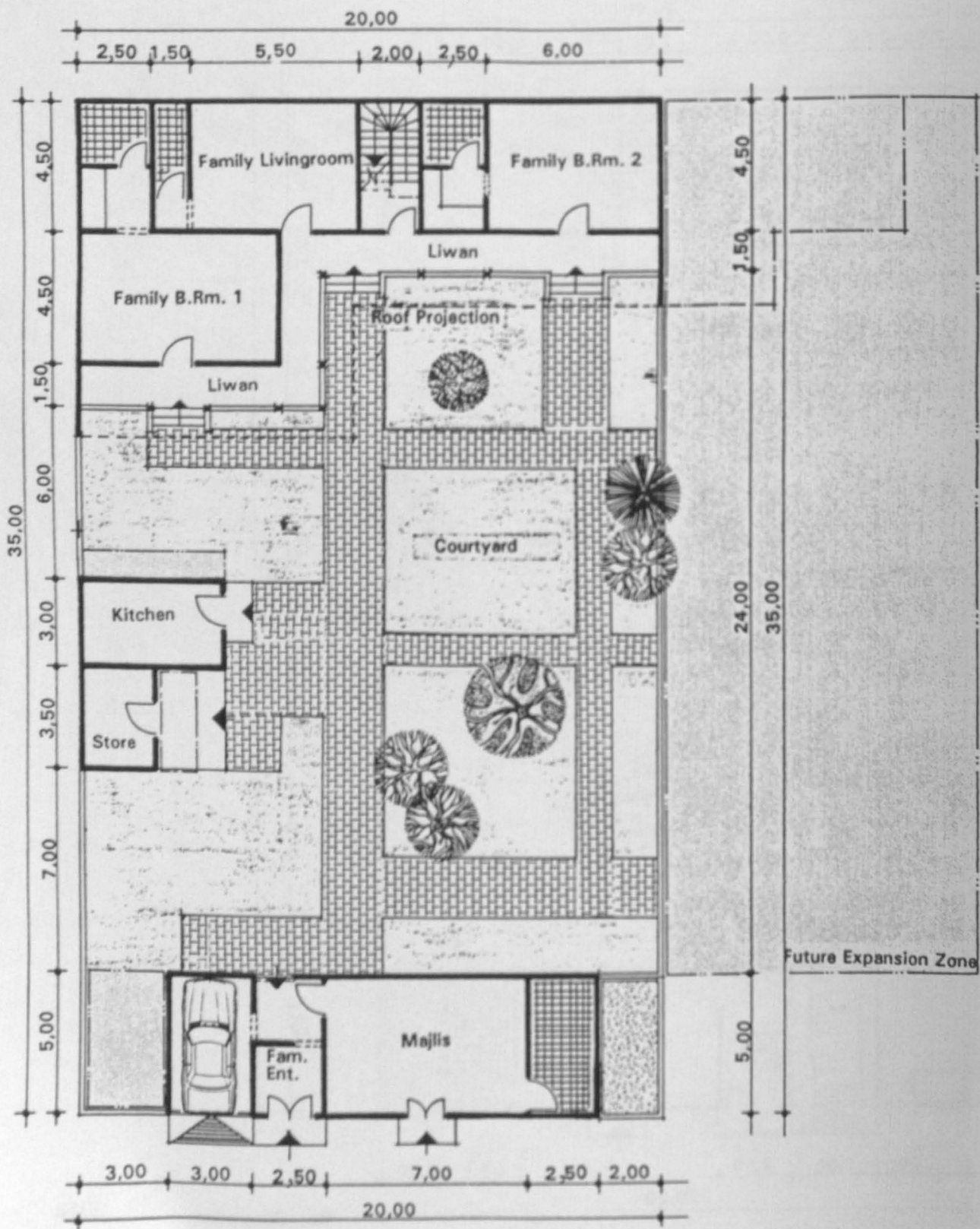

Fig 45 : Solution 5 Size A
Scale 1:200

Rec. Orientation



204B



205A Fig 46 : Solution 5 Size B
Scale 1:200

Rec. Orientation



Solution 5 - Size A

a The courtyard shape allows air channelling around the house buildings.

b Kitchen does not allow bad smells to be carried away to the house buildings.

c The built-up surface area = 157.50 m^2

Plot surface area = 1030.00 m^2

Ratio of built-up surface area to plot surface area is:

$$157.50 / 1030.00 = 15.29 \%$$

Solution 5 - Size B

a The courtyard shape allows air channelling around the house buildings.

b Kitchen does not allow bad smells to be carried away to the house buildings.

c The built-up surface area = 198.75 m^2

Plot surface area = 1030.00 m^2

Ratio of built-up surface area to plot surface area is:

$$198.75 / 1030.00 = 19.29 \%$$

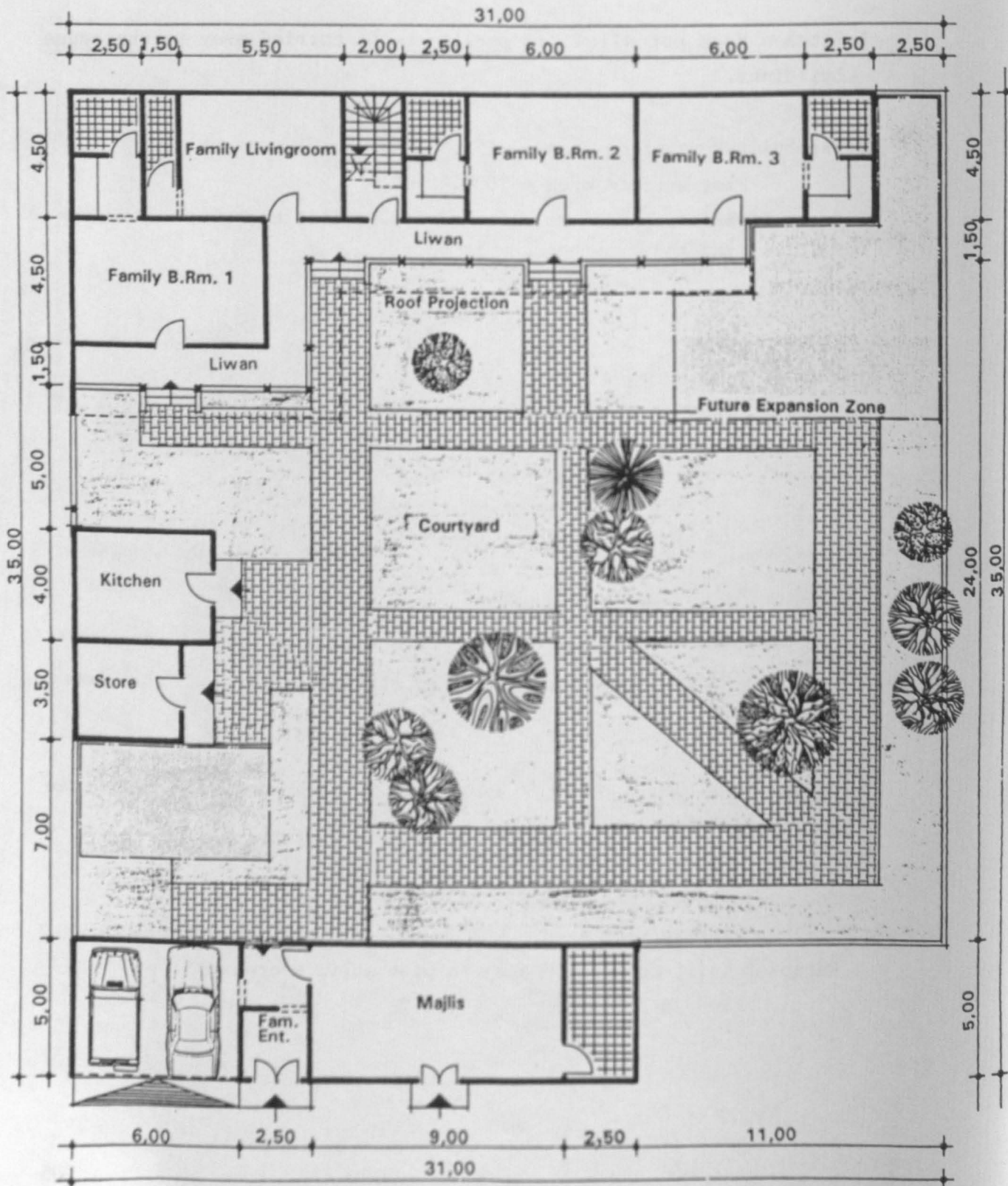
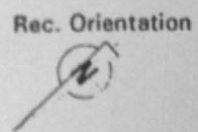

Fig 47 : Solution 5 Size C
Scale 1:200



Solution 5 - Size C

a The courtyard shape allows air channelling around the house buildings.

b Kitchen does not allow bad smells to be carried away to the house buildings.

c The built-up surface area = 262.00 m²

Plot surface area = 1030.00 m²

Ratio of built-up surface area to plot surface area is:

$$262.00 / 1030.00 = 25.44 \%$$

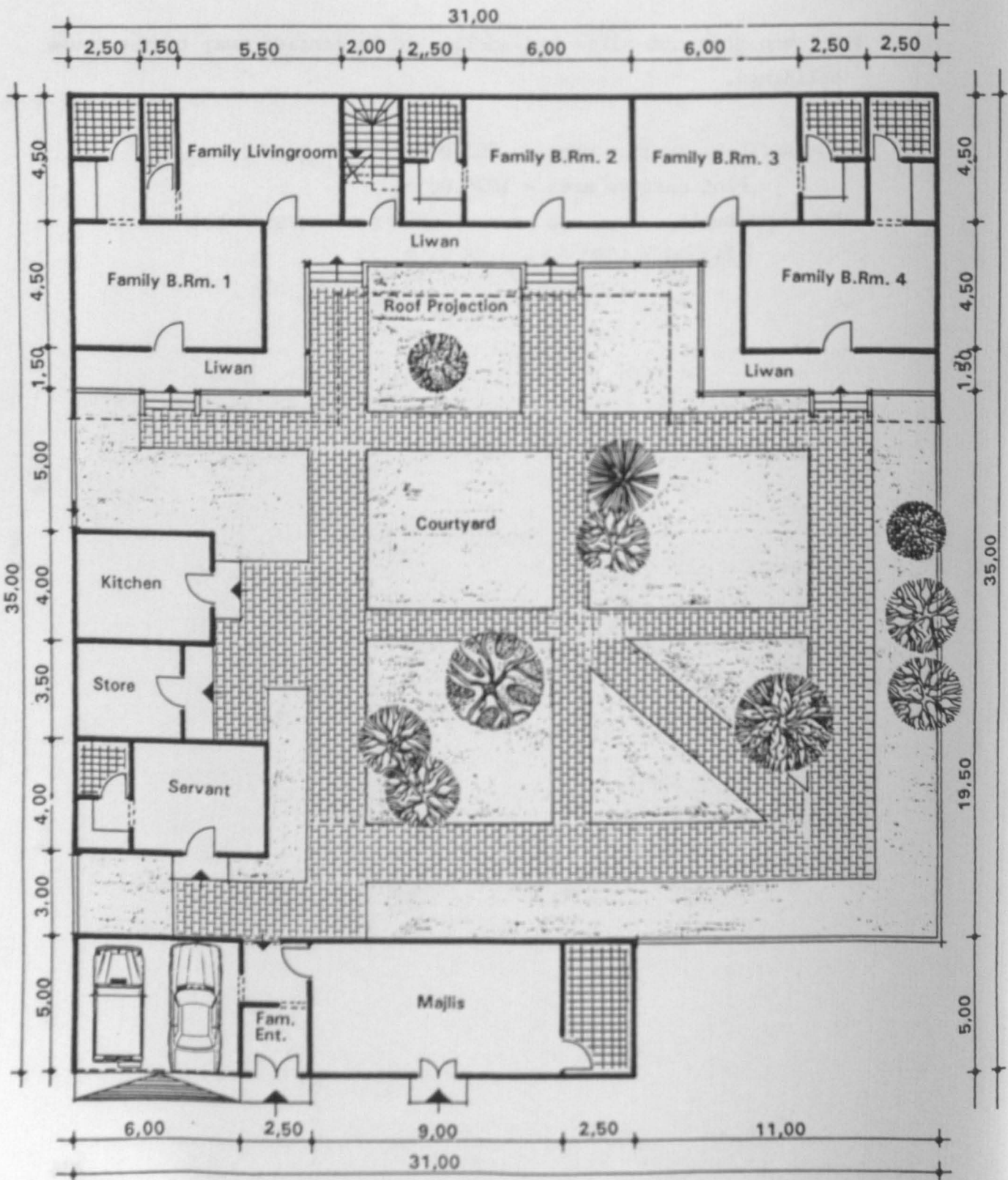
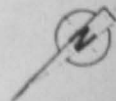

Fig 48 : Solution 5 Size D

Scale 1:200

Rec. Orientation



Solution 5 - Size D

a The courtyard shape allows air channelling around the house buildings.

b Kitchen does not allow bad smells to be carried away to the house buildings.

c The built-up surface area = 341.50 m²

Plot surface area = 1030.00 m²

Ratio of built-up surface area to plot surface area is:

$$341.50 / 1030.00 = 33.15 \%$$

SIZE	Recommended Built-up Surface area	Yard- stick	SOLUTION				
			1	2	3	4	5
A	141 m ²	a	3	2	2	2	4
		b	X	-	-	-	0
		c	-----	-----	-----	-----	157.50
B	200 m ²	a	3	2	2	3	4
		b	X	-	-	0	0
		c	-----	-----	-----	212.00	198.75
C	264 m ²	a	3	2	3	3	4
		b	X	-	0	0	0
		c	-----	-----	265.75	276.50	262.00
D	341 m ²	a	3	1	3	3	3
		b	X	-	0	0	0
		c	-----	-----	353.00	368.50	341.50

Thus successful design solution of type II are:

Solution 5 size A

Solution 5 size B

Solution 5 size C

Solution 5 size D

Proposed elevations of the selected design solutions of the dwelling units type II are shown in figures 49 and 50.

Recommended typical wall-window and sun screens details are shown in figures 51 and 52.

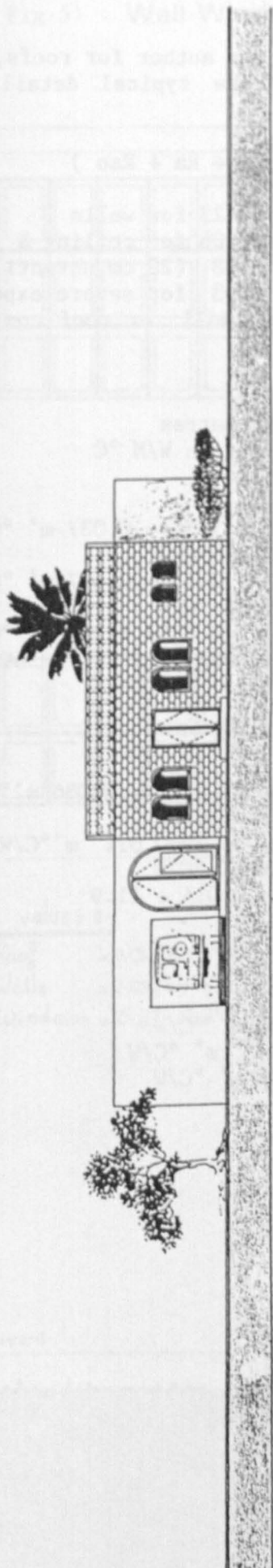

Fig 49 : Solution 5 Size A - B
Front Elevation
Scale 1:200

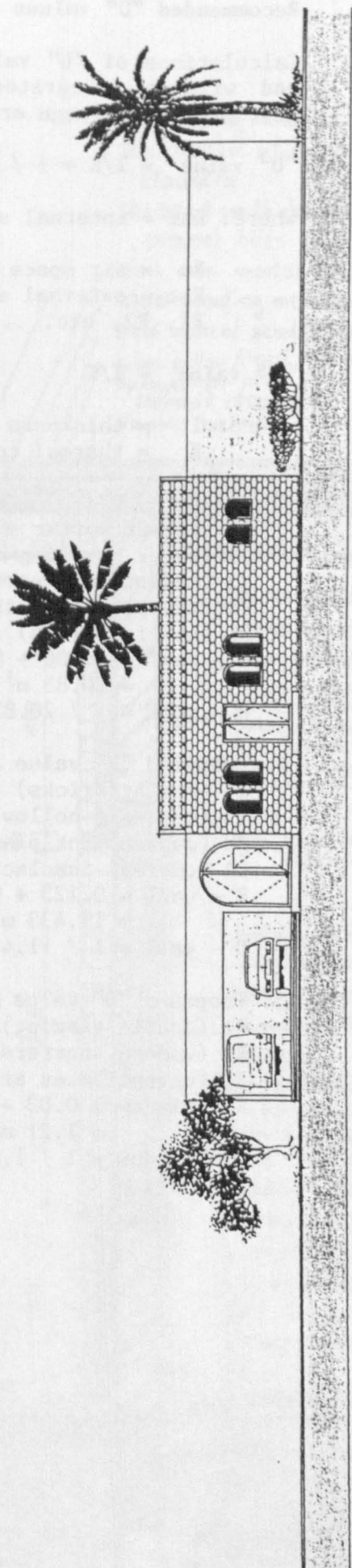
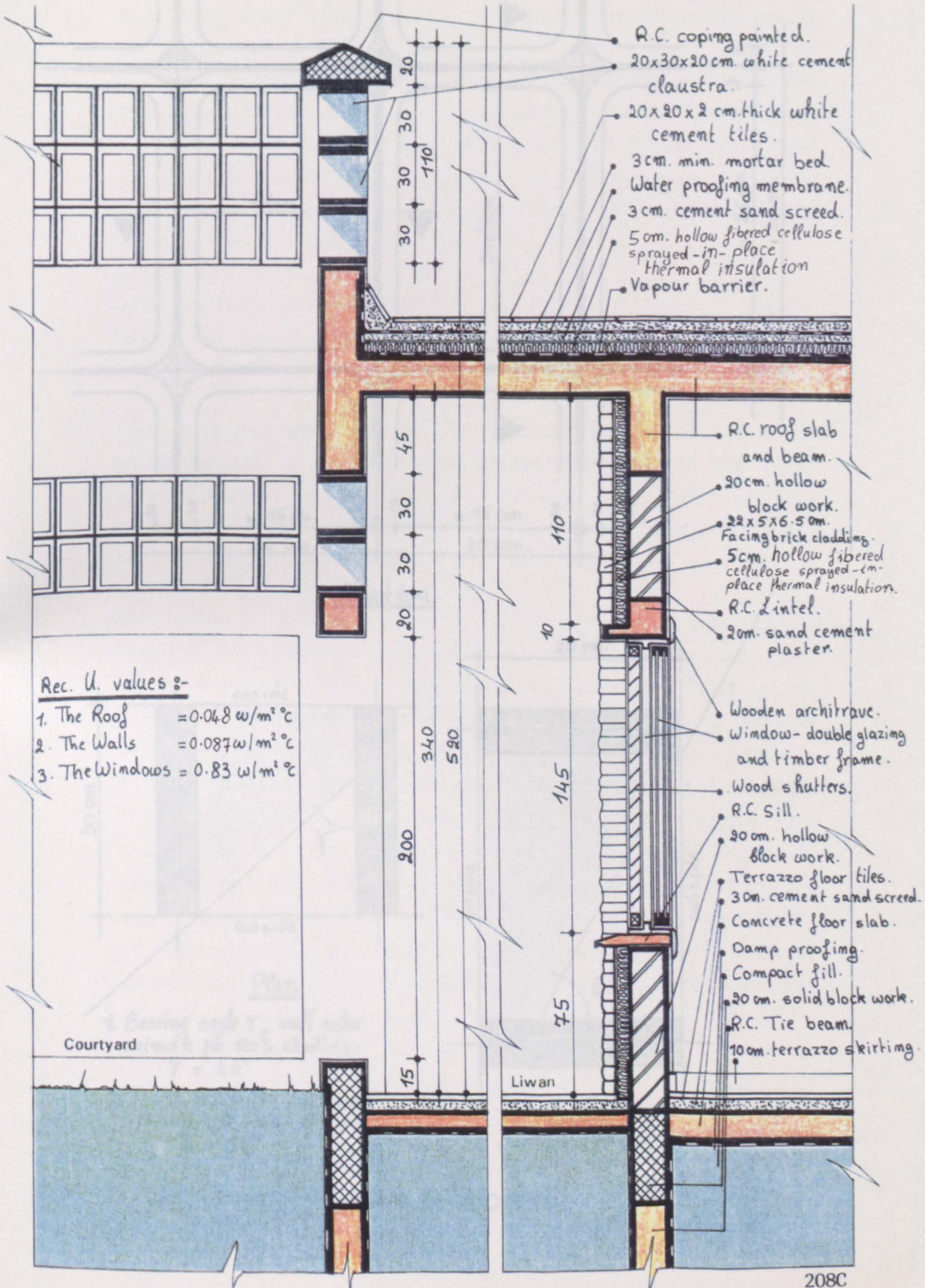

Fig 50 : Solution 5 Size C - D
Front Elevation
Scale 1:200

Fig 51 : Wall-Window Typical Detail

Scale 1:25



■ 20x30x20 white cement claustra. ■

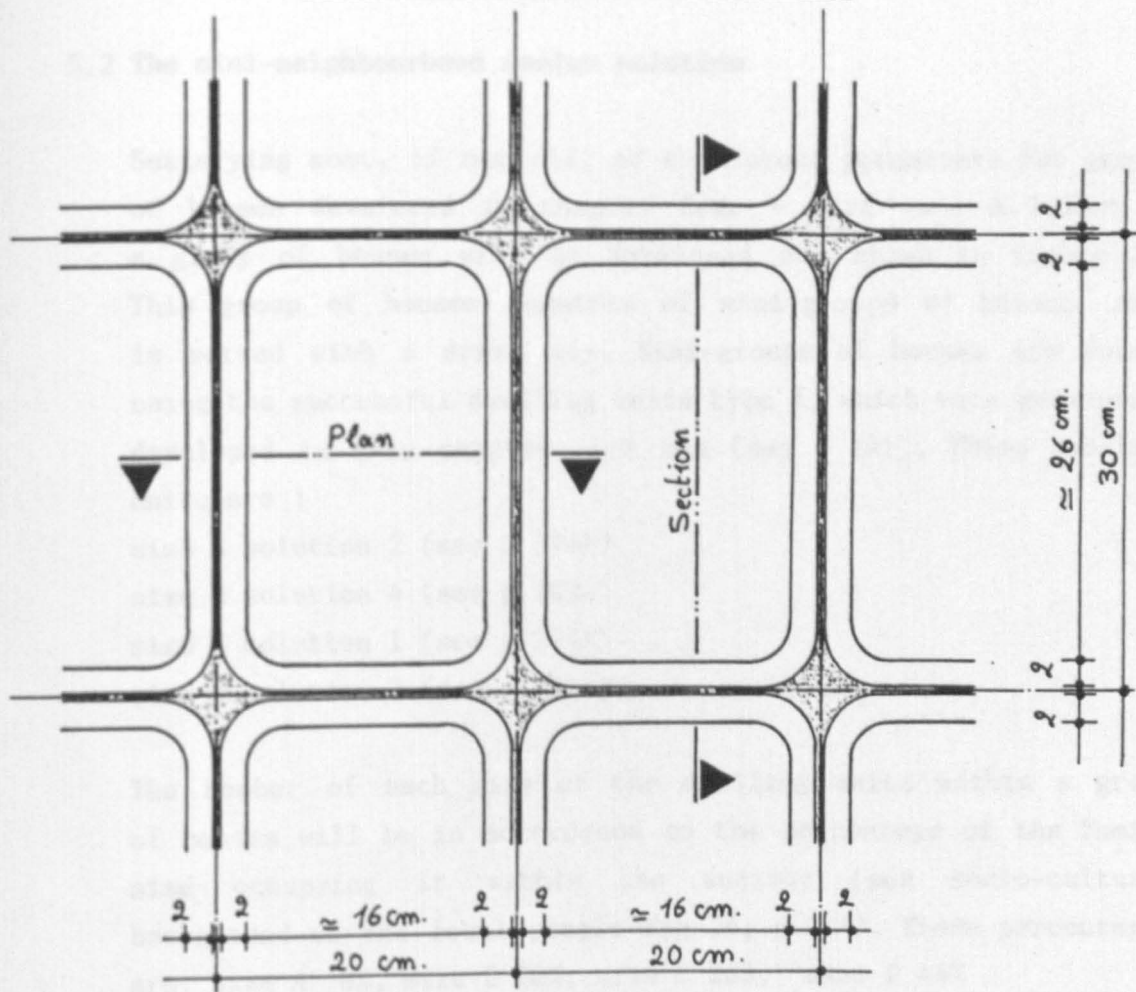

Elevation.

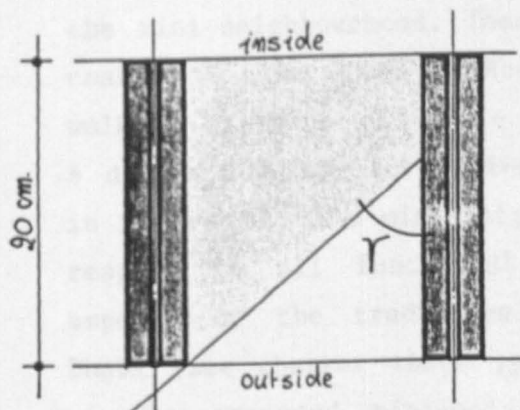

Plan

1. Bearing angle γ , wall solar azimuth for 100% shading:
 $\gamma = 40^\circ$

2. Profile angle β , wall solar altitude for 100% shading:
 $\beta = 61^\circ$

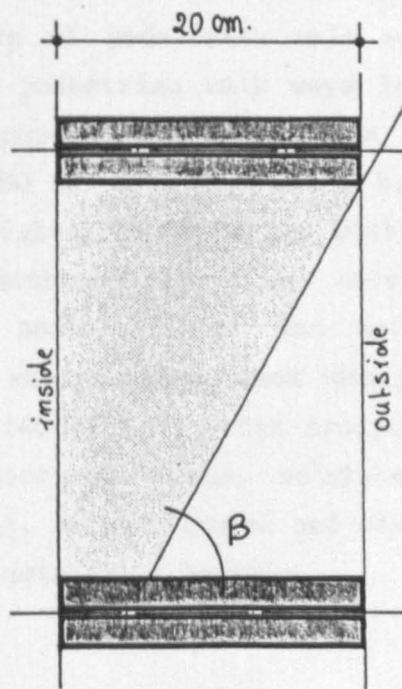

Section.

Fig 52 : Sun Screen Typical Detail

Scale 1:5

5.2 The mini-neighbourhood design solution

Satisfying most, if not all, of the layout parameters for groups of houses developed in chapter four - part two, a layout of a group of houses will be developed and shown in figure 53. This group of houses consists of mini-groups of houses, each is served with a drive way. Mini-groups of houses are formed using the successful dwelling units type I, which were previously developed in this chapter part one (see p 191). These dwelling units are :

size A solution 2 (see p 176A)

size B solution 4 (see p 182A)

size C solution 1 (see p 174A)

size D solution 3 (see p 181A)

The number of each size of the dwelling units within a group of houses will be in accordance to the percentage of the family size occupying it within the society (see socio-cultural background of the local people Fig 26, p 25A). These percentages are: size A 8%, size B 20%, size C 28%, size D 44%

The layout of similar groups of houses of various sizes linked together by a complex pattern of pedestrian walk ways, forms the mini-neighbourhood. These pedestrian walk ways lead to the centre of the mini-neighbourhood which is within a maximum walking distance of 350 - 400 m. (see Fig 16a & b, p 168A). A design solution for mini-neighbourhoods in Abu Dhabi is shown in figure 54. The mini-neighbourhood layout was developed with respect to all functional, socio-cultural and environmental aspects of the traditional mini-neighbourhood design in Abu Dhabi (see chapter three pp 146-149). A brief analytical study of the proposed mini-neighbourhood design solution will be carried out through: functional, socio-cultural and environmental aspects, where finally a conclusion will be made.

REMARKS : The layout of the dwelling units of various sizes within the group of houses has been carried out with respect to the recommended orientation for each shown in chapter five part one. This orientation is south to south-east for the house type I used in forming this group of houses



Fig 53 : A sketch that shows the layout of a group of houses within a mini-neighbourhood

Note : The scale of this drawing is 1/1000

Key to plan :

- walk ways
- drive ways
- green areas

Fig. 54 : A proposed design solution for mini-neighbourhoods in Abu Dhabi

Note : This drawing is a reduction from A3 to A4 size. The scale of drawing on A3 size is : 1 / 2000 .

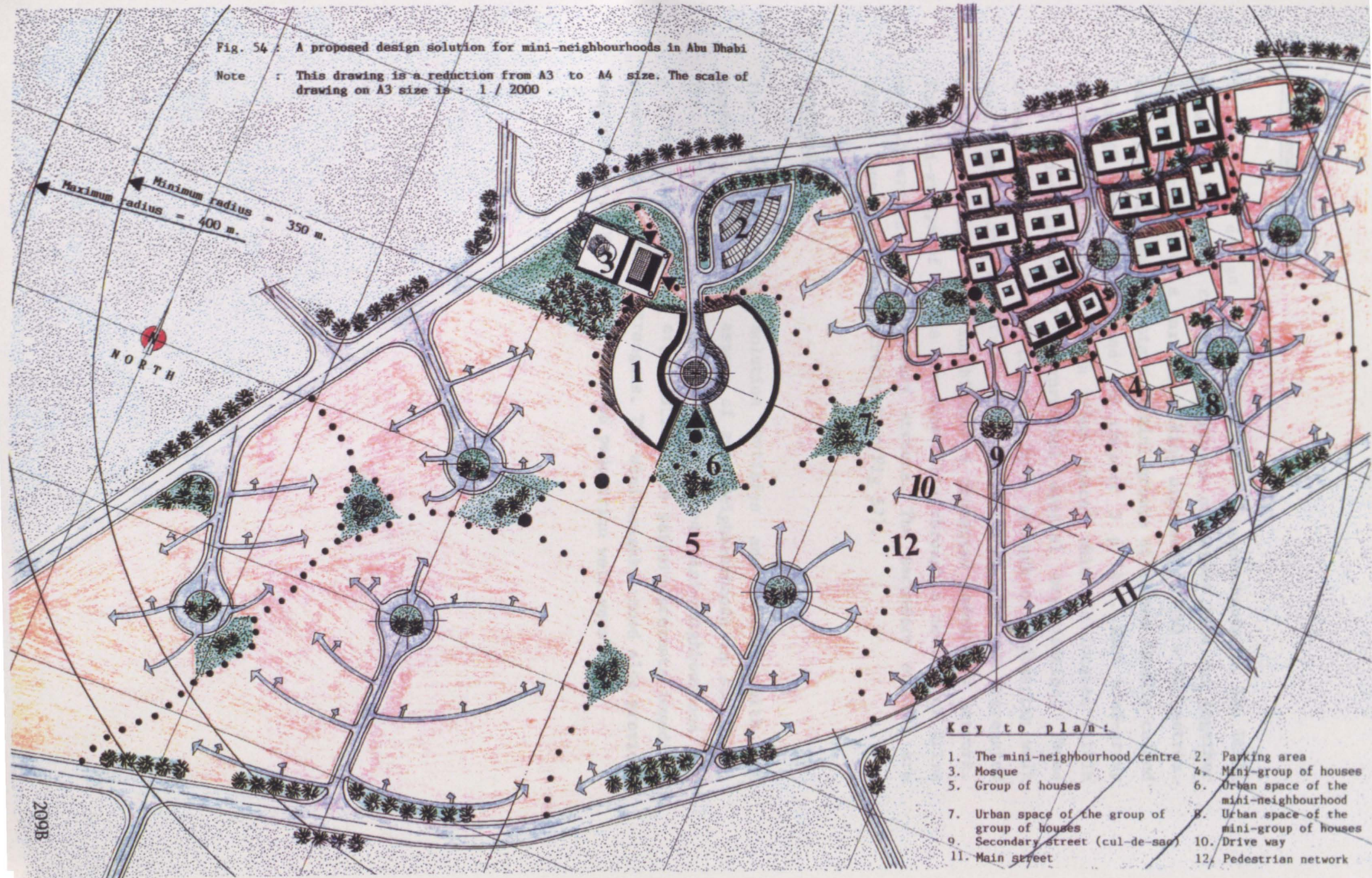

Functional Aspect

The proposed design solution for mini-neighbourhoods in Abu Dhabi shown in figure 54 consists of groups of houses laid out together within a radius of a maximum walking distance of 350 - 400 metres. Each group of houses consists of mini-groups of houses locally called "Fereej" (see Fig 55, and see chapter 3 p 146). Each mini-group of houses has its own open urban space, which is located within the mini-neighbourhood hierarchical spatial organisation. These urban spaces are linked together by a network of pedestrian walk ways (see Fig 56). Pedestrian walk ways and drive ways are segregated in order to offer the inhabitants a protected pedestrian network. The mini-groups of houses are accessible through a network of drive ways diverging from secondary streets. The secondary streets are linked together by main streets (see Fig 57).

Conclusion

The proposed design solution satisfies and conform with the traditional functional aspect of mini-neighbourhoods in Abu Dhabi. The functional structure of the proposed mini-neighbourhood has a hierarchical spatial organisation. Its pattern prevents immediate physical intrusion of strangers. The mini-neighbourhood also provides segregation between drive ways and pedestrian walk ways..

Fig 55 : A sketch that shows the hierarchical spatial organisation of the proposed mini-neighbourhood.

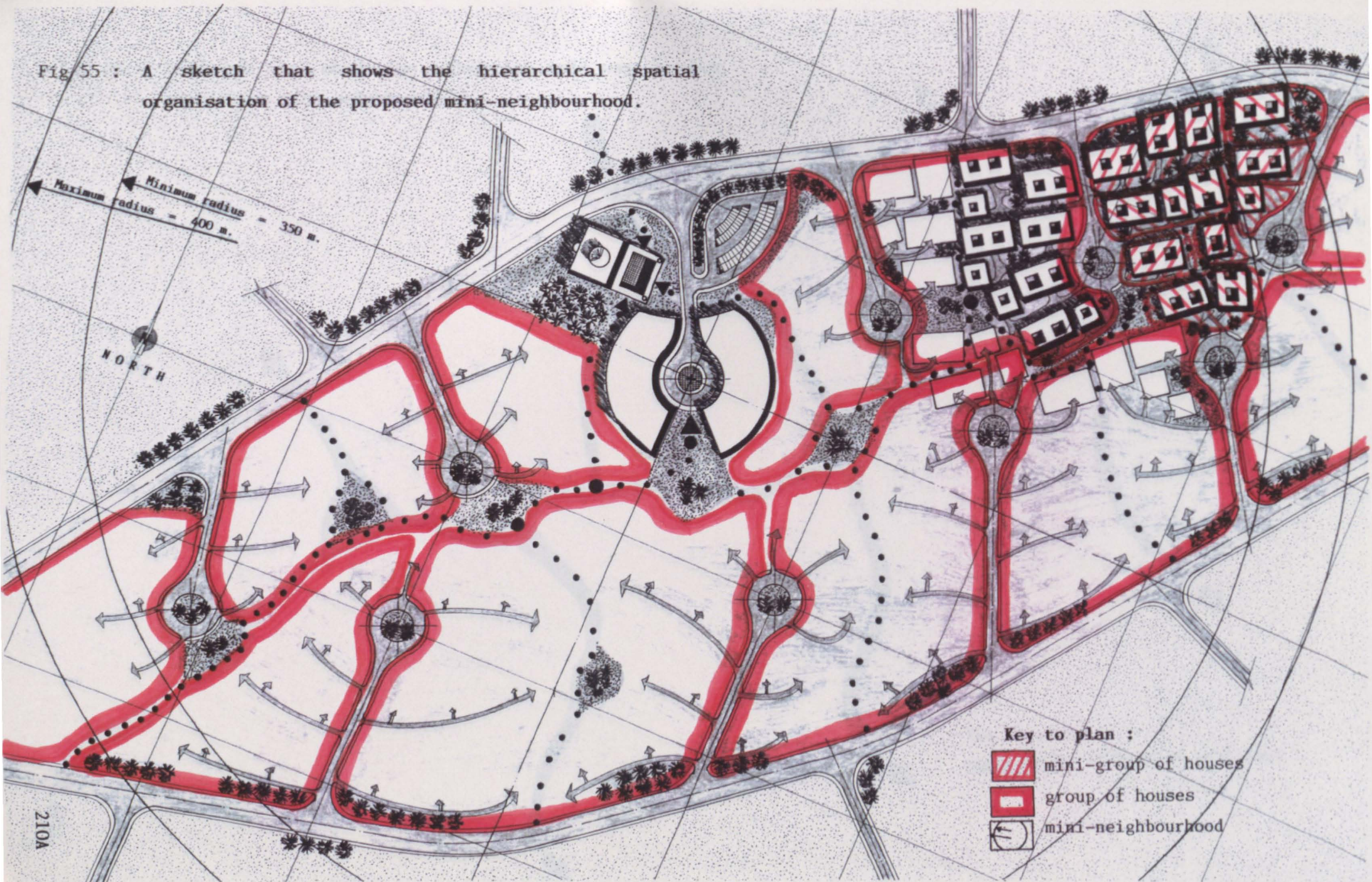

Fig 56 : A sketch that shows the pedestrian walk ways network within the mini-neighbourhood

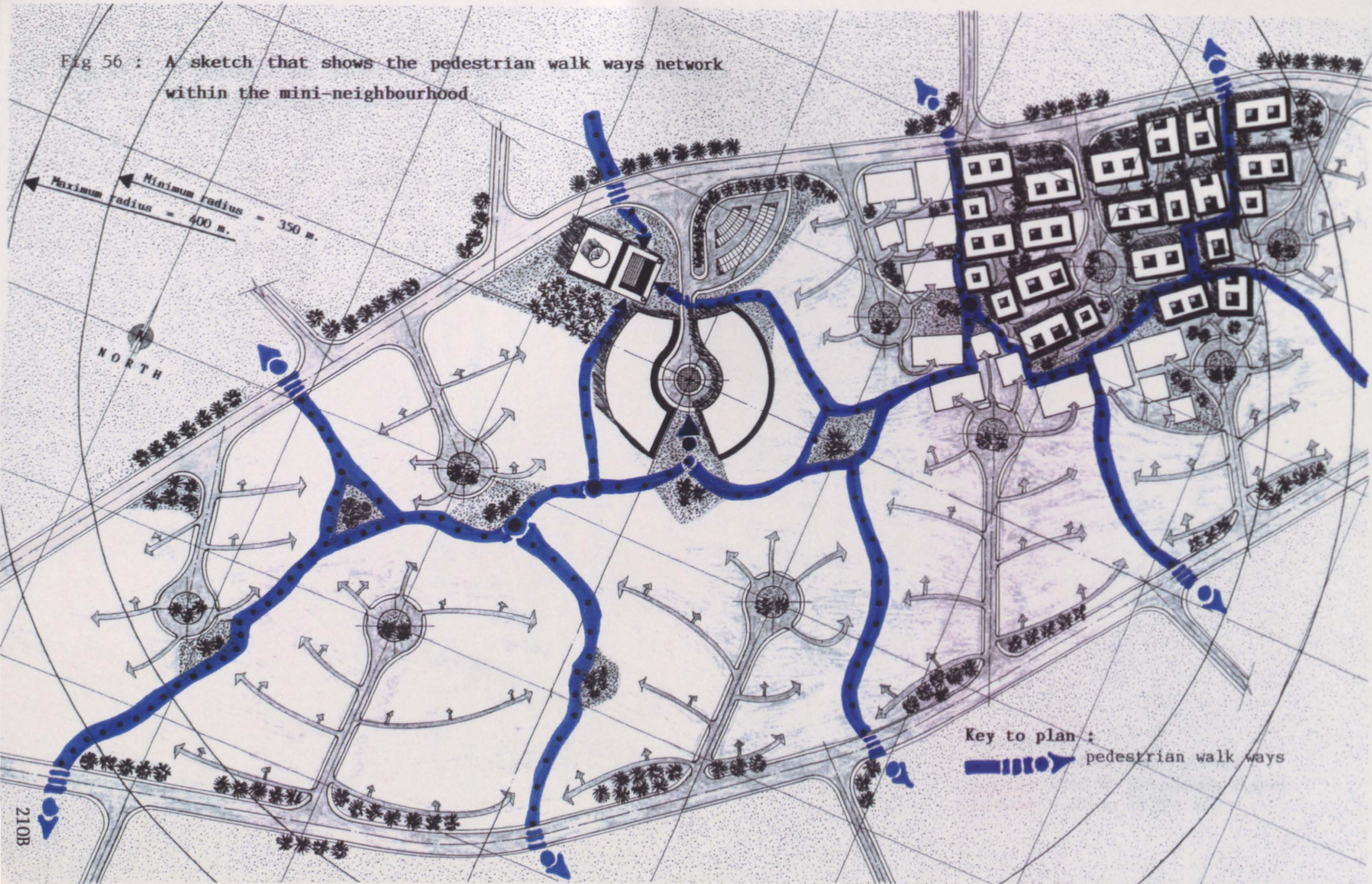
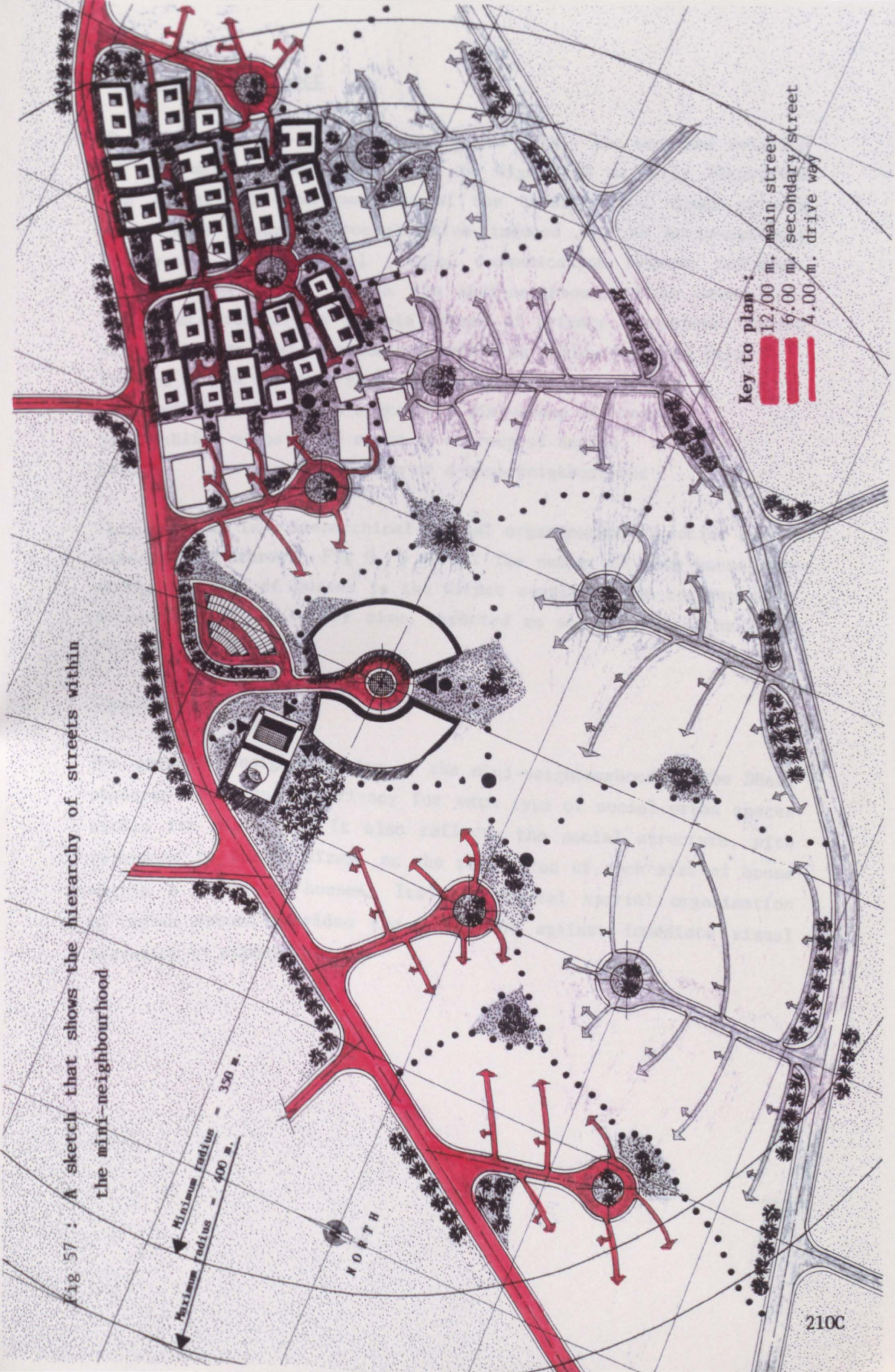

Fig 57 : A sketch that shows the hierarchy of streets within the mini-neighbourhood



Socio-cultural Aspect

The design of the social urban spaces within the proposed solution of the mini-neighbourhood shown in figure 54 directly interprets the social behaviour patterns of the local people. Since privacy is a very important social value induced by the socio-cultural background of the local people, communication between different social urban spaces within the mini-neighbourhood is controlled. Each space requires a certain degree of privacy. Therefore, spaces within the proposed solution are ranked as follow (see Fig 58):

- Private = the courtyard of a house
- Semi-private = the urban space of a mini-group of houses
- Semi-public = the urban space of a group of houses
- Public = the urban space of a mini-neighbourhood

This resulted in a hierarchical spatial organisation of social spaces (see chapter three - Fig 8, p 147A). The number of each house size within a group of houses is the direct result of the corresponding percentage of the family size, expected to occupy it, in the local society (see Fig 59).

Conclusion

The proposed design solution of the mini-neighbourhood in Abu Dhabi achieves the required privacy for each type of social urban spaces within its structure. It also reflects the social structure, with reference to family sizes, on the repetition of each size of house within a group of houses. Its hierarchical spatial organisation of urban spaces provides the protection against immediate visual intrusion by strangers.

Fig 58 : A sketch that shows the hierarchical organisation of urban spaces within the mini-neighbourhood

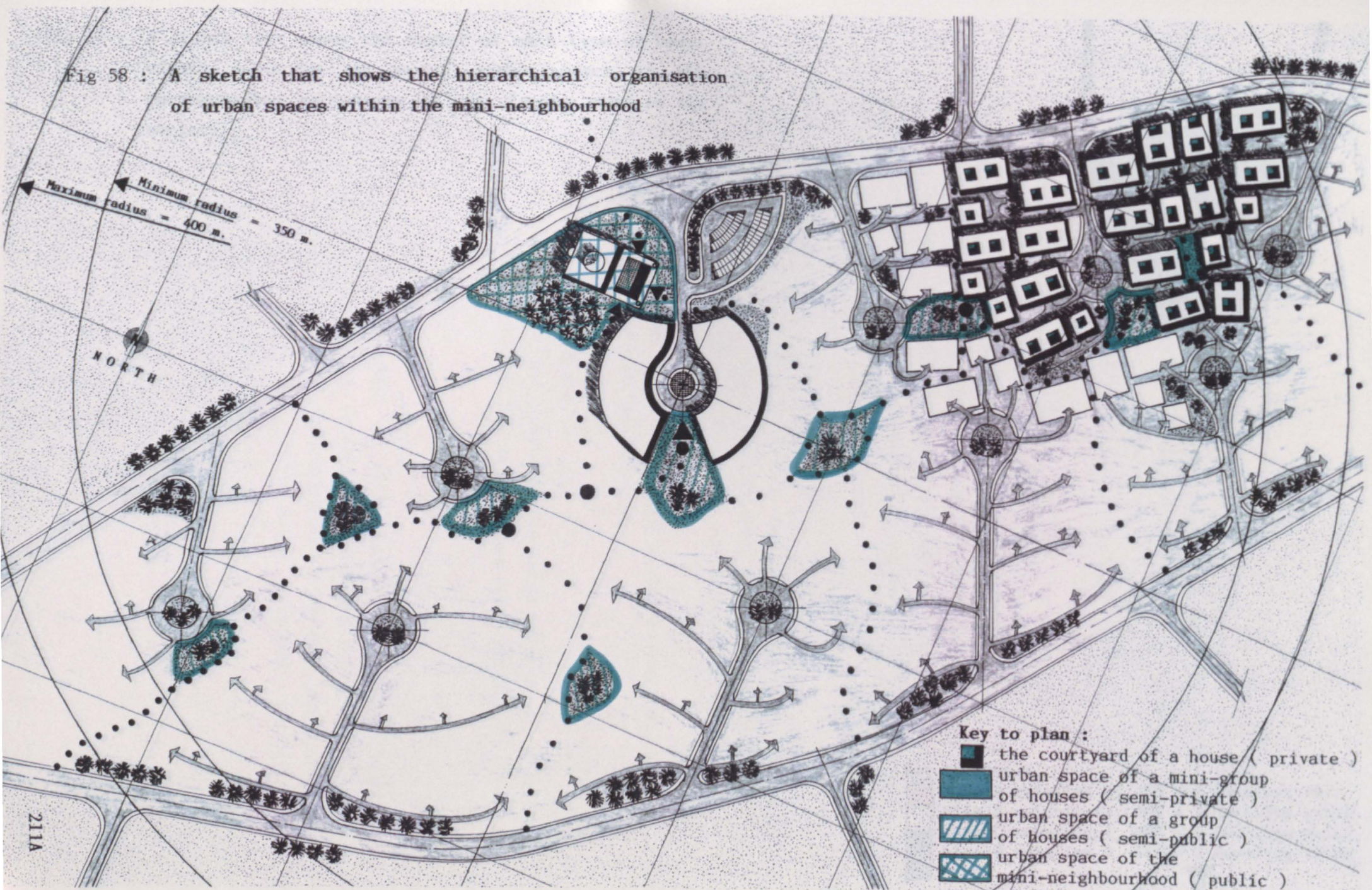
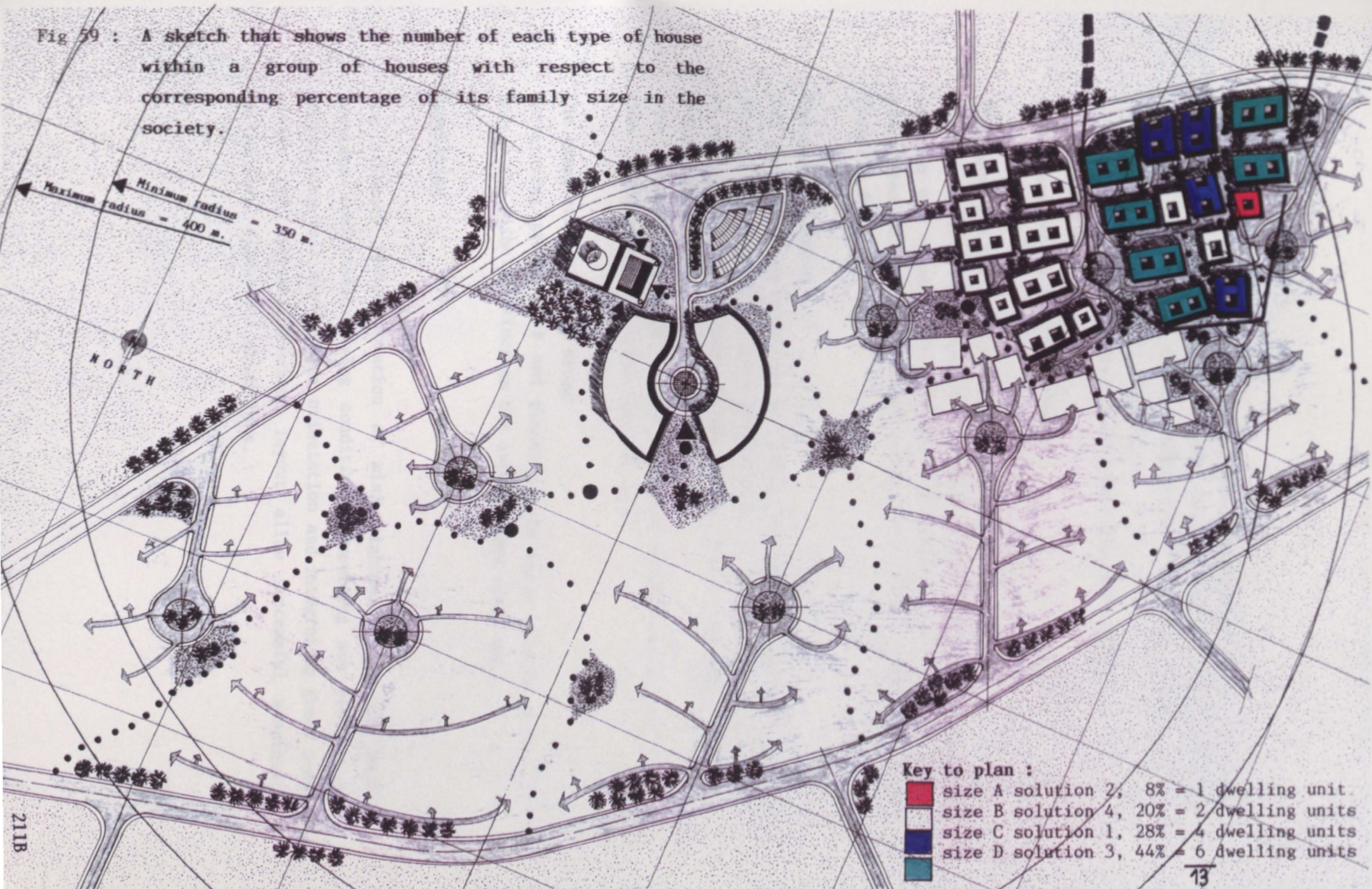

Fig 59 : A sketch that shows the number of each type of house within a group of houses with respect to the corresponding percentage of its family size in the society.



211B

Environmental Aspect

The proposed design solution for mini-neighbourhoods in Abu Dhabi minimises the discomforts of the local climate. The following elements helped successful adaptation to the severe local environmental conditions, which are:

- The shape and the orientation of pedestrian walk ways.
- The sun protection.
- The integration of green areas.

The shape and the orientation of pedestrian walk ways

Pedestrian walk ways are of irregular linear shapes, where most of them are of north to north-west orientation. This allows both, pedestrian walk ways and urban spaces to be shaded most of the day (see Fig 60).

The sun protection

Sun protection is achieved by laying out houses relatively close to each other which provides mutual shading. The ratio of the width of the pedestrian walk ways to the height of the surrounding boundary walls, which is :

walk way width $W = (1.50 - 3.00) \times H$ height of the boundary walls

Thus increasing shaded areas (see Fig 61).

The integration of green areas

Integrating green areas and planting palm trees provide shade and soften the climatic effect on the outdoor open urban space.

Conclusion

The proposed design solution of mini-neighbourhood in Abu Dhabi provides comfortable living conditions. Providing sun protection, maintaining walk ways proper orientation and integrating green areas within the mini-neighbourhood layout allow successful adaptation to the local climatical conditions.

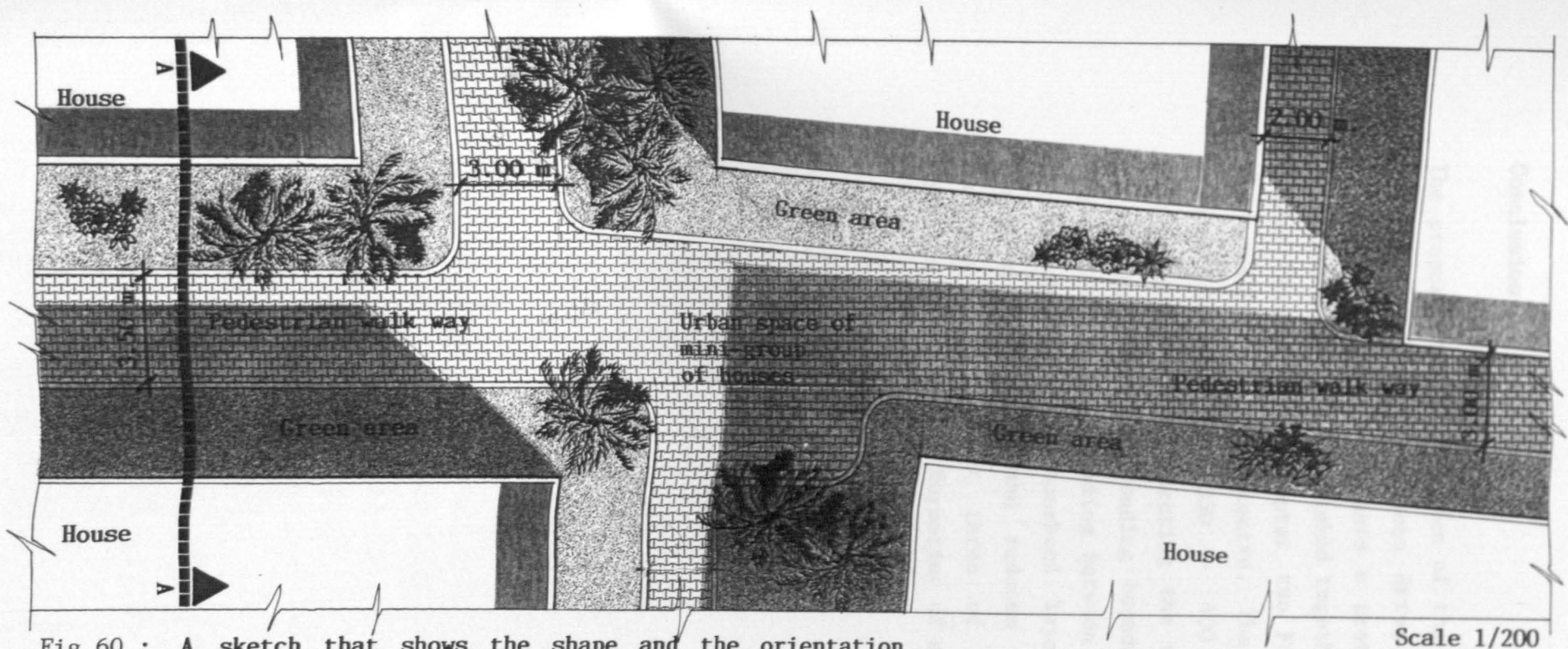

Fig 60 : A sketch that shows the shape and the orientation of pedestrian walk ways

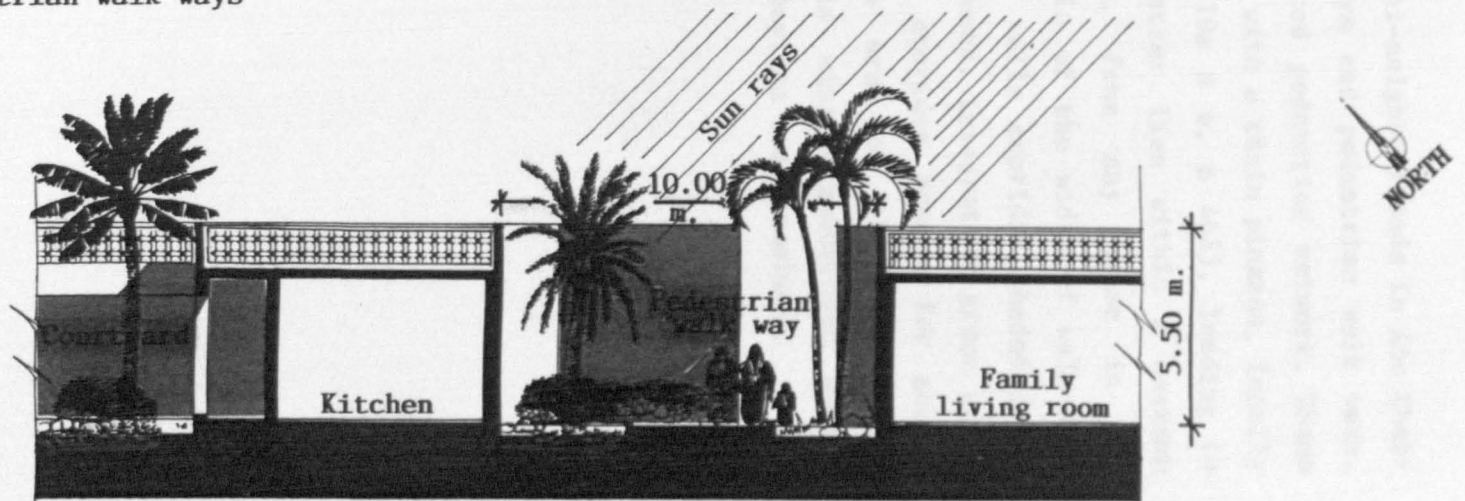

Fig 61 : A sketch that shows section A-A passing through a pedestrian walk way

Conclusion

The proposed design solution of the mini-neighbourhoods in Abu Dhabi provides segregation between drive ways and pedestrian walk ways, which offers the inhabitants a protected pedestrian network. These divergent walk ways are linked together with a chain piazzas, locally called "barayeh"(see chapter two Fig 19a & b, p 46A), leading to the mini-neighbourhood centre. The latter lies within a maximum walking distance of 350 - 400 m. from any house in the mini-neighbourhood. Respecting the ratio of the width of walk ways to the height of surrounding boundary walls provides shaded areas and achieves mutual shading between houses. Integrating green areas within the mini-neighbourhood layout provides spaces for social contacts, gatherings and reduces the area of glare reflecting surfaces. Thus two or three of this mini-neighbourhood design solution can serve the formation of a complete neighbourhood.

List of Figures

- Figure 5/1 : Size A Solution 1
- Figure 5/2 : Size B Solution 1
- Figure 5/3 : Size C Solution 1
- Figure 5/4 : Size D Solution 1
- Figure 5/5 : Size A Solution 2
- Figure 5/6 : Size B Solution 2
- Figure 5/7 : Size C Solution 2
- Figure 5/8 : Size D Solution 2
- Figure 5/9 : Size A Solution 3
- Figure 5/10 : Size B Solution 3
- Figure 5/11 : Size C Solution 3
- Figure 5/12 : Size D Solution 3
- Figure 5/13 : Size A Solution 4
- Figure 5/14 : Size B Solution 4
- Figure 5/15 : Size C Solution 4
- Figure 5/16 : Size D Solution 4
- Figure 5/17 : Size A Solution 5
- Figure 5/18 : Size B Solution 5
- Figure 5/19 : Size C Solution 5
- Figure 5/20 : Size D Solution 5
- Figure 5/21 : Size A Solution 6
- Figure 5/22 : Size B Solution 6
- Figure 5/23 : Size C Solution 6
- Figure 5/24 : Size D Solution 6
- Figure 5/25 : Size A Solution 2
Front Elevation
- Figure 5/26 : Size B Solution 4
Front Elevation
- Figure 5/27 : Size C Solution 1
Front Elevation
- Figure 5/28 : Size D Solution 3
Front Elevation
- Figure 5/29 : Solution 1 Size A
- Figure 5/30 : Solution 1 Size B

- Figure 5/31 : Solution 1 Size C
- Figure 5/32 : Solution 1 Size D
- Figure 5/33 : Solution 2 Size A
- Figure 5/34 : Solution 2 Size B
- Figure 5/35 : Solution 2 Size C
- Figure 5/36 : Solution 2 Size D
- Figure 5/37 : Solution 3 Size A
- Figure 5/38 : Solution 3 Size B
- Figure 5/39 : Solution 3 Size C
- Figure 5/40 : Solution 3 Size D
- Figure 5/41 : Solution 4 Size A
- Figure 5/42 : Solution 4 Size B
- Figure 5/43 : Solution 4 Size C
- Figure 5/44 : Solution 4 Size D
- Figure 5/45 : Solution 5 Size A
- Figure 5/46 : Solution 5 Size B
- Figure 5/47 : Solution 5 Size C
- Figure 5/48 : Solution 5 Size D
- Figure 5/49 : Solution 5 Size A-B
Front Elevation
- Figure 5/50 : Solution 5 Size C-D
Front Elevation
- Figure 5/51 : Wall-Window Typical Detail
- Figure 5/52 : Sun Screen Typical Detail
- Figure 5/53 : A sketch that shows the layout of a group of houses within a mini-neighbourhood
- Figure 5/54 : A sketch that shows an example for a mini-neighbourhood which consists of various groups of houses as that shown in figure 53
- Figure 5/55 : A sketch that shows the hierarchical spatial organisation of the proposed mini-neighbourhood.
- Figure 5/56 : A sketch that shows the pedestrian walk ways network within the mini-neighbourhood
- Figure 5/57 : A sketch that shows the hierarchy of streets within the mini-neighbourhood
- Figure 5/58 : A sketch that shows the hierarchical organisation

of urban spaces within the mini-neighbourhood

Figure 5/59 : A sketch that shows the number of each type of house within a group of houses with respect to the corresponding percentage of its family size in the society.

Figure 5/60 : A sketch that shows the shape and the orientation of pedestrian walk ways

Figure 5/61 : A sketch that shows section A-A passing through a pedestrian walk way

Chapter Six

Summary and recommendations for further research

In this chapter the summary of the research work already carried out will be made, and recommendations for further research to be carried out with the aim of originating civilisational values in building the islamic cities in general and neighbourhoods in particular.

S u m m a r y

The responsible individuals of the low income housing policy in Abu Dhabi have been passing during the last 20-25 years through an endless number of trial and error design procedures trying to find convenient housing types for the local people. Various types of low income houses have been designed and built in large numbers forming new neighbourhoods and settlements, and still the local people have not been offered a house type that can substitute for their traditional houses. The increasing need of low income houses year after year due to the high rate of population growth, and the efforts of the concerned authorities of Abu Dhabi in modifying the design of housing types to satisfy the local people needs continue in vain. Since these efforts are based on simple contributions of individual architects of different origins, the problem of inconviency of low income houses in Abu Dhabi continues to exist. The need to find a solution for this problem became extremely important, where houses already built are abandoned, or completely modified, or totally insufficient. Various simple contributions of different governmental authorities, such as the post-occupancy housing survey carried out by the Planning Department of Abu Dhabi, helped knowing the needs of the local people. The absence of a detailed research work built on scientific bases encouraged the author to take the task. The research work carried out consists of five main chapters. The first chapter defines the problem conditions in order to understand the different dimensions of the case of study. In the second chapter detailed study of traditional types of houses built before the discovery of oil in Abu Dhabi; critical analysis of the contemporary types of low income houses built after the discovery of oil were carried out. A close view on the local people's current needs and preferences are obtained from the housing survey. In chapter three examples for both traditional and contemporary neighbourhoods are shown. The results of the detailed study, discription and analysis along with the defined needs of the local people helped developing dwelling unit standards, and layout parameters for groups of houses which are

In chapter five examples for systematic design procedure, based on the inputs of chapter four, are developed then evaluated in order to select most suitable ones. Recommendations for further research work and methods of conserving and originating civilisational values in building islamic cities are stated in this chapter. This research work will permit responsible individuals of the housing policy to understand the local people needs and provides them with the necessary tools and examples to deal with the design problem in the every day practical life. It is also the foundation stone on which more detailed research work should be based with a future vision of establishing complete design standards for housing projects in Abu Dhabi.

Recommendations for further research on the housing problem

In order to develop this research work in practical life, further detailed studies of the housing problem practical aspects should be carried out. The following aspects are recommended by the author for further research:

Economic aspect: establishing standard breakdowns of total cost of construction for various types of low income houses; constant analysis of building and finishing materials, local market prices and feedback to standard breakdowns, etc. ...

Climatical aspect: detailed laboratory studies on windows proper location and dimensions; the use of wind towers "al'barjeel", etc. ...

Esthetical aspect: originating local decoration forms and patterns; integrating functional decorative elements such as columns, arches, sun screens, etc. ...

Building regulations: detailed studies should be carried out in order to develop methods of originating civilisational values in building Abu Dhabi city that might be more efficient and practical.

Recommendations and methods of originating civilisational values in building the islamic cities in general and neighbourhoods in particular.

The current regulations of setting out land lots and construction lines in existing and new neighbourhoods do not allow the development of courtyard houses and assembling open areas in one or several courtyards, whereas they lead to the fragmentation of open spaces on the sides of the building. New laws and regulations concerning each neighbourhood and district in old, new and future expansion areas of the city should be set out. Detailed studies and scientific research work should be carried out to help establishing urban design criteria which aim for originating civilisational values in building Abu Dhabi's cities, and for the conservation of its islamic architectural heritage. This can be achieved through out the application of the following methods:

- 1st Method :** It aims for the presentation and conservation of the civilisational heritage of Abu Dhabi's architecture, whether it is in the form of single or groups of buildings. (1).
- 2nd Method :** It aims for applying the civilisational urban and architectural islamic values through the executional authorities, such as municipalities. (1).
- 3rd Method :** It aims for planning and designing new urban areas with respect to the urban and architectural values, taking into consideration recent technological achievements and modern life demands. Those which do not contradict civilisational values of the islamic society. (1).

List of Quotation

- (1) Ibrahim, A. B., "Originating Civilizational Values In Building The Contemporary Islamic City", Cairo, 1982, pp 126-131, (Title translated by the author).

B i b l i o g r a p h y

I UNPUBLISHED MATERIAL, GOVERNMENTAL PUBLICATIONS, ETC.

II BOOKS

III ARTICLES

IV PERIODICALS

V SOME FURTHER READINGS

B i b l i o g r a p h y

I UNPUBLISHED MATERIAL, GOVERNMENT PUBLICATIONS, ETC.

AFIFI, A. K. & SARHAN, A., *Climatic Factors And Their Effect On The Ueban Design In The United Arab Emirates*, a research paper, Al'Ain-Abu Dhabi, 1985 (Title translated by the author).

AL'MASAWY, H., *Houses Internal Layouts In The United Arab Emirates*, a research paper, Abu Dhabi, 1989

GOVERNMENT OF ABU DHABI, DEPARTMENT OF PLANNING, *Post-occupancy Housing Survey*, Abu Dhabi, 1987 (Title translated by the author).

GOVERNMENT OF ABU DHABI, DEPARTMENT OF PLANNING, *Statistical Year Book*, Abu Dhabi, 1976, 1984, 1986, 1987, 1988.

GOVERNMENT OF BAHRAIN, GENERAL PLANNING & ORGANISING DIRECTORATE, *Annual Statistical Bulletin*, Part One, 1969.

GOVERNMENT OF ABU DHABI, GENERAL INDUSTRY CORPORATION, *Industry In Abu Dhabi*, The First Year Book, 1980

GOVERNMENT OF ABU DHABI, HERITAGE AND TOURISM DIRECTORATE, *The United Arab Emirates Heritage*, 1979

GOVERNMENT OF ABU DHABI, MINISTRY OF CULTURE AND COMMUNICATION, DEPARTMENT OF HERITAGE AND TOURISM, *Tourism In The U. A. E.*, 1975.

GOVERNMENT OF ABU DHABI, MINISTRY OF CULTURE AND COMMUNICATION, *United Arab Emirates*, The Year Book, 1975.

GOVERNMENT OF ABU DHABI, MINISTRY OF INFORMATION, *The U.A.E.*, 197?.

GOVERNMENT OF ABU DHABI, PUBLIC WORKS DEPARTMENT, *10 N°s. Low-cost Houses*, Project N°: 1-1-416 / 1R, Abu Dhabi, 1987.

HOWEEDY, M. A., *A Study Suggesting Contemporary Urban Design Guidl-*
220

ines Using The United Arab Emirates As An Illustrative Case, a Masters Thesis, Michigan, 1989.

JUMA, M. A., *Urban Development In The United Arab Emirates And In Abu Dhabi City*, a Thesis submitted to the Department of Geography and Geology, Eastern Michigan University in partial fulfilment of the requirement for the degree of Master of Science in Geography, Michigan, 1985.

MATLOUB, A., *Reconstruction Of Sheikh Saeid Al'Maktoum House*, a research paper, Abu Dhabi, 1989.

SALMANI, T. M. A., *Privacy In Housing - Perception And Applications In Islamic Architecture*, a research paper, Abu Dhabi, 1989.

UNITED ARAB EMIRATES UNIVERSITY, THE DEPARTMENT OF ARCHITECTURE
Selected Subjects In Urban Design, a course N°: 73564 by SOLIMAN, B M., Al'Ain - Abu Dhabi, 1986/87.

WAHBY, H. A. M., *Originating Civilisational Values Of Privacy In Contemporary Houses*, a research paper, Abu Dhabi, 1989

II BOOKS

AL'KATIB, A. Sh., *A New Dictionary Of Scientific And Technical Terms*, 5th ed, Librairie Du Liban, Beirut, 1982.

AL'WAKEEL, S. & SERAG, A., *Climate & Hot Regions Architecture*, Al-Tobgy Publishing Company, Cairo, 1985.

BROADBENT, G., *Design In Architecture, Architecture And The Human Sciences*, John Wiley & Sons Ltd., London, N. Y., Sydney, Toronto, 1973.

BROADBENT, G., *Design In Architecture, Architecture And The Human Sciences*, David Fulton Publishers, London, 1988.

CALLENDER, J. H. , *Time - Saver Standards For Architectural Design*

Data, 6th ed, McGraw Hill, New York, 1982.

CODRAI, R., *The Seven Sheikdoms*, Stacey International, London, 1990

EL'ABDOULY, K. G., *Prevailing Trends In The Architecture Of The United Arab Emirates*, El-Ettihad Publishing Establishment, Abu Dhabi, 1989.

EL'ABOUDY, N. H., *Studies On The United Arab Emirates Heritage And Archeology*, Bin Desmal - Abu Dhabi Printing & Publishing Est., Abu Dhabi, 1990. (Title translated by the author).

EL'HAGGAG, Y. A. et al, *The United Arab Emirates - A Comprehensive Surveyal Study*, Egyptian Printing Company & Publishing, Cairo, 1978 (Title translated by the author).

EL'SABBAGH, I. R., *Pearl Fishing*, El-Dar El-Arabia Publidhers, Beirut, 1983.

EL'TAEI, L. A., *Localisation Of Beduins In Abu Dhabi*, Al-Razi Office, Beirut, 1974, (Title translated by the author).

EVANS, M., *Housing, Climate And Comfort*, The Architectural Press , London / Halsted Press Division and John Wiley & Sons, New York, 1980

FAEGRE, T., *Tents - Architecture Of The Nomads*, John Murray, London, 1979.

FENELON, K. G., *The U. A. E.*, Longman, London, 1973

HANDAL, F., *The Detailed Of The United Arab Emirates History*, Dar El-Fikr Publishing Est., Abu Dhabi, 1983 (Title translated by the author).

HEARD-BEY, F., *From Trucial States To United Arab Emirates, A Society In Transition*, Longman Group Limited, London, 1982, 1984.

HILLIER, B. & HANSON, J., *The Social Logic Of Space*, Cambridge University Press, Great Britain, 1984.

IBRAHIM, A. B. & Ibrahim, H. M., *The Historic Perspective Of Architecture In Eastern Arabia*, International Press & C. P.A.S., Cairo, 1987 (Title translated by the author).

IBRAHIM, A. B., *The Islamic Perspective Of The Architectural Theory* International Press & C.P.A.S., Cairo, 1986, (Title translated by the author).

IBRAHIM, A. B., *Originating Civilisational Values In Building The Contemporary Islamic City*, International Press & C.P.A.S., Cairo, 1982 (Title translated by the author).

JONES, J. C., *Design Methods. Seeds Of Human Futures*, Wiley - Inter Science / John Wiley & Sons Ltd., London, New York, Sydney, Toronto 1970.

JONES, J. C., *Design Methods. Seeds Of Human Futures*, John Wiley & Sons Ltd., A Wiley - Inter Science Publication, Chichester, New - York, Brisbane, Toronto, 1970, 1980.

JONES, J. C., *Design Methods*, 2nd ed, Van Nostrand Reinhold, New - York, 1992.

KOENIGSBERGER, O. H. et al, *Manual Of Tropical Housing And Building Part One : Climatic Design*, Longman Group Ltd., London, 1974

MANN, C., *Abu Dhabi, Birth Of An Oil Sheikdom*, Khayats, Beirut , 1964.

McGinness, W. J. et al, *Mechanical And Electrical Equipment For Buildings*, 6th ed, John Wiley & Sons, New York, 1980.

MITCHELL, G., *Architecture Of The Islamic World - History & Social Meaning*, Thames & Hudson Ltd., London, 1978.

NEUFERT, E., *Architects' Data*, 2nd Int. ed, Granada, Halsted Press
John Wiley & Sons Inc., New York, 1982.

OBRIEN, E., *Arabia Days*, Quartet Book, London, 1977.

QADER, N. A. & EL-TOUNI, S. M., *In Designing And Planning Of Urban Areas - Introduction Applications*, Published By The Authors, Cairo, 1988 (Title translated by the author).

RAMZY & SLEEPER, *Architectural Graphic Standards*, 7th ed, John Wiley & Sons, New York, Chichester, Brisbane, Toronto, 1981.

SALVADORI, M. & LEVY, M., *Structural Design In Architecture*, 2nd ed, Prentice - Hall, New Jersey, 1981.

SHARAF, M. Y., *The Emirates Society*, Dar Al-Mutanaby Printing & Publications, Abu Dhabi, 1990.

TAMMAM, H., *Zayed Bin Sultan Al-Nahian - The Leader And The March*, Dai Nippon Printing Co. Limited, Tokyo, Japan, 1981.

VINE, P. & CASEY, P., *Arab Gold - Heritage Of The U. A. E.*, Immel, Japan, 1989.

III ARTICLES

ABDUL-KARIM, M., " *El'Khaleej Opens The File Of The Low-cost Houses (6)* ", in the Al'Khaleej Newspaper, vol 3740, 1989, p 3, (Title translated by the author).

ABDUL-KARIM, M., " *Housing And The Urgent Needs (4)* ", in the Al'Khaleej Newspaper, vol 4244, 1990, p 4, (Title translated by the author).

EL'BOSHY, M., " *El'Khaleej Opens The File Of The Low-cost Houses (1)* ", in the Al'Khaleej Newspaper, vol 3734, 1989, p 3, (Title translated by the author).

HAMDAN, S., " *El'Khaleej Opens The File Of The Low-cost Houses (7)*"
in the Al'Khaleej Newspaper, vol 3742, 1989, p 3, (Title translated
by the author).

IV PERIODICALS

Al'Ettihad, Arabic Language Daily, Abu Dhabi

Al'Khaleej, Arabic Language Daily, Abu Dhabi

Asian Affairs, Journal Of The Royal Central Asian Society, London

Dubai Visitor, English Language, Dubai

Emirates News, English Language Daily, Abu Dhabi

V SOME FURTHER READINGS

HEARD-BEY, F., *Development Anomalies In The Beduin Oases Of Al-Liwa*
The Royal Central Asian Society, London, 1974

KAY, S. & ZANDI, D., *Architectural Heritage In The Gulf*, Motivate
Publishing, Dubai, 1991

ORGANISATION OF ISLAMIC CAPITALS AND CITIES, PROCEEDINGS OF A SYMP-
OSIUM HELD IN ANKARA - TURKEY, *Housing In The Islamic City*, edited
by : Center Of Planning And Architectural Studies, International P-
ress, Cairo, 1986

THE SAUDI ARABIAN GOVERNMENT, JEDDAH MUNICIPALITY, *Up - Grading Of*
The Urban Environment Of Cities, prepared by the Center Of Planning
And Architectural Studies, Dar-Al-Shorouk, Cairo, 1986

IBRAHIM, M.A., *The Gulf Architecture Between Originality*
And Renovation, Part Two, (publisher unknown), Cairo,
1972, (Title translated by the author).

SWEET'S GROUP, *Sweet's International Building Products*, Worldwide
Edition, McGraw Hill, Inc., New York, 1994

HOLM, D., *Energy Conservation In Hot Climates*, The Architectural Press, London, 1983