

**Designing Effective Interface
Configurations in Touchscreen
Eyes-free Interaction**

by

Munyaporn Pooripanyakun

A thesis submitted to the University of Strathclyde

for the degree of Doctor of Philosophy

Department for Design, Manufacturing and Engineering Management

University of Strathclyde

2022

Declaration of Authenticity and Author's Rights

This thesis is the result of the author's original research. It has been composed by the author and has not been previously submitted for examination which has led to the award of a degree.

The copyright of this thesis belongs to the author under the terms of the United Kingdom Copyright Acts as qualified by University of Strathclyde Regulation 3.50. Due acknowledgement must always be made of the use of any material contained in, or derived from, this thesis. The copyright of this thesis belongs to the author under the terms of the United Kingdom Copyright Acts as qualified by the University of Strathclyde Regulation 3.51. Due acknowledgement must always be made of the use of any material contained in, or derived from, this dissertation.

Signed: *Munyarun Pooripanyahm*

Date: *24/2/2023*

Acknowledgements

The past 4 years in the PhD journey have actually been the most challenging years of my life. There are a number of people who have made this endeavor possible I would like to thank them for their support. Firstly, I would like to express my gratitude to my academic supervisors, Dr. Andrew Wodehouse and Prof. Jorn Mehnert. They provided many valuable insights, continuing guidance, and dedicated support throughout my studies.

I would like to thank all the participants and interviewees who devoted their time and effort to many experiments and investigations. Human-centred design research would not have been possible without their voluntary contributions. Their participation is much appreciated.

I would also like to thank all the academic staff of DMEM and the reviewers who provided constructive feedback on my research. I also owe a debt of gratitude to the Ministry of Higher Education, Science, Research and Innovation and my current agency, King Mongkut's University of Technology North Bangkok for a government scholarship in science and technology.

I must also thank my special person, my brother, and my cousin-sister for a lot of helpful support, several fruitful discussions, and for introducing me to meet many experienced UI/UX designers. Lastly, thanks to my family, friends and, colleagues for all the support and positive encouragement while I have faced many challenges and exhaustion.

Abstract

Smartphones are considered ubiquitous in our daily life, allowing us to conveniently manipulate data while simultaneously performing other tasks. Unfortunately, our interaction with smartphone interfaces can act as a distraction from other activities which could put the user at risk. Without unique tactile cues on the touchscreen, the users are forced to devote more attention to carrying out their task at hand. Interface design for eyes-free interaction with a featureless screen is therefore a highly challenging, and informative approach. By simplifying and optimising menu layout patterns and understanding how to locate and memorise active touchpoints, there is an opportunity to create touchscreen interfaces that harness innate human abilities and product affordances, allowing the reduction of levels of visual attention. Therefore, this research aims to enhance understanding of human cognitive abilities that are proprioception and spatial memory to deliver a framework and guidelines that help support effective eyes-free interface configurations of touchscreen surfaces.

The configuration of interface elements in relation to thumb motion under the mobile screen frame and human spatial memory become key aspects to be considered in designing an eyes-free interface for one-handed mobile interaction. The interface prototypes were developed to test for certain qualities of design. Two experiments are conducted to test the performance accuracy of interfaces caused by spatial memory and proprioception. Participants need to memorise the visual interface which has been viewed before imagining a relative spatial layout and tap on a match position of the target with tactile sense on the unseen flat mobile screen. Insight from the experimental findings brought about the development of the design framework suggesting key interface configuration characteristics to synergise the strengths of spatial memory and proprioception. These include horizontal alignment, structure with even button spacing, unified layout, middle segmentation, symmetry in a square, and proximity to the device frame within a comfortable thumb range. Following the development of this novel conceptual framework, design guidelines were then developed to support the practitioner to configure the eyes-free interfaces to attain high accuracy and efficiency.

In the practical study, three novel application layouts were proposed and evaluated. In addition, interviews with experienced user interface designers were conducted for insights into the suitability of the design framework and design guidelines. The fundamentals in this thesis have the potential to be used in designing touchscreen layouts allowing better interaction with smartphones with a low level of visual attention. This thesis demonstrates a contribution to knowledge through the development and application of eyes-free interface prototypes.

Relevant papers by the author

Pooripanyakun, M., Wodehouse, A., & Mehnen, J. (2020). The Effect of Time Pressure on the Performance of Dexterous Operations. *Proceedings of the Design Society: DESIGN Conference*, 1, 1521-1530.

Pooripanyakun, M., Wodehouse, A. & Mehnen, J. (2022). The design and evaluation of an eyes-free touchscreen interface, *Human Interaction & Emerging Technologies (IHET-AI 2022): Artificial Intelligence and Future Applications*. New York, 10 p.

Pooripanyakun, M., Wodehouse, A. & Mehnen, J. The Role of Interface Configuration on Performance Accuracy in Eyes-free Touchscreen Interaction. *Universal Access in the Information Society*, 1-17. Paper submitted.

Table of Contents

| | |
|---|-----------|
| Acknowledgements | i |
| Abstract..... | ii |
| Relevant papers by the author | iii |
| Table of Contents | iv |
| List of Figures..... | viii |
| List of Tables | xi |
| Chapter 1 Introduction | 1 |
| 1.1 Motivation of the research | 4 |
| 1.2 Aim and objectives..... | 7 |
| 1.3 Thesis structure..... | 7 |
| 1.4 Summary..... | 9 |
| Chapter 2 A literature review of researches on human factors in interface and interaction design | 11 |
| 2.1 Background | 11 |
| 2.2 Human cognitive ability | 12 |
| 2.3 Human hand and control | 17 |
| 2.4 Spatial memory (SM)..... | 21 |
| 2.5 Proprioception (PP)..... | 22 |
| 2.6 Human senses for eyes-free interaction on target selection tasks..... | 26 |
| 2.7 Mobile interaction and user interface design | 28 |
| 2.8 Discussion | 31 |
| 2.9 Summary..... | 34 |
| Chapter 3 Research Approach | 35 |
| 3.1 Research Philosophy..... | 35 |
| 3.2 Research design..... | 38 |
| 3.3 Research techniques..... | 41 |

| | | |
|---|---|----|
| 3.4 | Research ethics..... | 43 |
| 3.5 | Summary..... | 44 |
| Chapter 4 Understanding human ability under spatial interfaces for dexterous operation..... | | |
| | | 45 |
| 4.1 | Aim of preliminary study..... | 46 |
| 4.2 | Task design and experiment procedure..... | 47 |
| 4.3 | Result and analysis..... | 51 |
| 4.4 | Discussion..... | 55 |
| 4.5 | Insights into the spatial interface and interaction design..... | 56 |
| 4.6 | Summary..... | 58 |
| Chapter 5 Spatial interface prototype development for eyes-free touchscreen interaction..... | | |
| | | 60 |
| 5.1 | Eyes-free interaction and spatial interface design on touchscreen mobile..... | 60 |
| 5.2 | Requirements definition..... | 62 |
| 5.3 | Conceptual design (First iteration)..... | 65 |
| 5.4 | Development of experimental apparatus (Screen recording app)..... | 70 |
| 5.5 | Detailed design (Second iteration)..... | 72 |
| 5.6 | Summary..... | 77 |
| Chapter 6 Understanding human spatial memory and proprioception of the eye-free interface to develop a design framework..... | | |
| | | 78 |
| 6.1 | Design of experiment..... | 79 |
| 6.1.1 | Experimental protocol..... | 81 |
| 6.1.2 | Participants..... | 84 |
| 6.1.3 | Data processing..... | 84 |
| 6.1.4 | Data analysis..... | 85 |
| 6.2 | Experiment 1 (Serial presentation mode)..... | 86 |
| 6.2.1 | Task and procedure..... | 86 |
| 6.2.2 | Hypotheses..... | 90 |

| | | |
|--|--|------------|
| 6.2.3 | Results | 90 |
| 6.3 | Experiment 2 (Single layout presentation mode) | 97 |
| 6.3.1 | Task and procedure | 97 |
| 6.3.2 | Hypotheses | 98 |
| 6.3.3 | Results | 99 |
| 6.4 | Discussion | 107 |
| 6.4.1 | Analysis of the results | 107 |
| 6.4.2 | Analysis of the interface configurations | 110 |
| 6.5 | Implications for design | 114 |
| 6.6 | Summary | 116 |
| Chapter 7 Design guideline development and validation of eyes-free interface design | | 117 |
| 7.1 | Development of design guidelines | 117 |
| 7.2 | Designing eyes-free interface prototypes | 122 |
| 7.3 | Evaluation of eyes-free interfaces for applications on a touchscreen | 124 |
| 7.3.1 | Participants | 127 |
| 7.3.2 | Questionnaire design and results on interface configuration formats | 127 |
| 7.3.3 | Task design and experimental procedure in the usability study | 130 |
| 7.3.4 | Measures and data analysis | 133 |
| 7.3.5 | Results | 133 |
| 7.3.6 | Discussion | 138 |
| 7.4 | Interviewing with user interface designers | 141 |
| 7.4.1 | Methodology | 142 |
| 7.4.2 | Results | 143 |
| 7.4.3 | Summary of designer feedback | 149 |
| 7.5 | Improvement of design guidelines | 150 |
| 7.6 | Summary | 152 |
| Chapter 8 Summary and conclusions | | 153 |

| | | |
|------------|---|-----|
| 8.1 | Overview of the research | 153 |
| 8.2 | Research contributions | 156 |
| 8.3 | Limitations and future works | 159 |
| 8.4 | Concluding remarks | 161 |
| | References | 162 |
| | Appendices | 176 |
| | Appendix 1 The mind map of the inspiration phase for eyes-free interaction | 177 |
| | Appendix 2 The layouts for eyes-free interaction in the ideation phase | 178 |
| | Appendix 3 Specification of experimental prototypes | 180 |
| | Appendix 4 The processing method of the raw data | 183 |
| | Appendix 5 Analysis method of the repeated measures ANOVA | 185 |
| | Appendix 6 Data on the distance error from Experiment 1 | 188 |
| | Appendix 7 Data on the distance error from Experiment 2 | 196 |
| | Appendix 8 Specification of application prototypes | 206 |
| | Appendix 9 Questionnaire on interface configuration formats | 207 |
| | Appendix 10 Data on the touch coordinates from the usability test | 213 |
| | Appendix 11 Interview questions | 221 |
| | Appendix 12 Interview transcript example | 225 |

List of Figures

| | |
|--|----|
| Figure 1.1 Handheld devices or controllers | 1 |
| Figure 1.2 Human-Mobile Interaction (HMI) relating to User Interface (UI)..... | 2 |
| Figure 1.3 Smartphone usage in different contexts..... | 4 |
| Figure 2.1 Field of research | 12 |
| Figure 2.2 Human cognitive processes (Adapted from Bailey, 1982)..... | 14 |
| Figure 2.3 Mobile interfaces and menu interface layouts..... | 16 |
| Figure 2.4 Hand bones (Photo from Rob Swatski)..... | 18 |
| Figure 2.5 Top view of the back of the right hand (simplified kinematic model)..... | 19 |
| Figure 2.6 Kinetic anatomy and finger postures under single-handed thumb interaction | 20 |
| Figure 2.7 Factors that influence spatial memory..... | 22 |
| Figure 2.8 Motor control pathways in interacting with manipulable object under proprioceptive system, contributing to eyes-free interaction..... | 24 |
| Figure 2.9 Factors that affect the proprioception..... | 26 |
| Figure 2.10 Icon size and spacing in the home screen menu and mobile application | 29 |
| Figure 3.1 Stratified ontology of Critical Realism (Adapted from Saunders et al., 2015) | 37 |
| Figure 3.2 The overall research design and techniques | 42 |
| Figure 4.1 Dexterous operation study on the spatial interface..... | 45 |
| Figure 4.2 The set-up in the experiment on Task 1: typing the 20 words of Thai letters | 48 |
| Figure 4.3 The set-up in the experiment on Task 2: assembling the 20 pieces of a jigsaw puzzle..... | 49 |
| Figure 4.4 Experimental set-up..... | 51 |
| Figure 4.5 Protocol of the experiment | 51 |
| Figure 4.6 An example of the result and button locations of typing errors in Task 1..... | 52 |
| Figure 4.7 Examples of the results and error patterns in Task 2..... | 54 |
| Figure 4.8 The speed increment comparison on Task 1 and Task 2 between the fixed and moving interface | 56 |
| Figure 4.9 Eyes-free interaction within the context of spatial memory and proprioception.. | 58 |
| Figure 5.1 Eye-free interaction schema on a touchscreen mobile | 61 |
| Figure 5.2 Characteristics of target configuration that impact both spatial memory and proprioception, derived from the literature review | 62 |
| Figure 5.3 House of quality for eyes-free interface | 64 |
| Figure 5.4 Paper prototypes in the ideation phase | 67 |
| Figure 5.5 The touchscreen test app used during ideation phase..... | 68 |

| | |
|---|-----|
| Figure 5.6 Testing on the touchscreen test app in the ideation phase..... | 69 |
| Figure 5.7 The final concept of experimental prototypes | 70 |
| Figure 5.8 Experimental apparatus in this research | 71 |
| Figure 5.9 The software development system to record data in the experiments | 72 |
| Figure 5.10 Layouts of eyes-free interface prototypes in different orientations..... | 73 |
| Figure 5.11 The representation of interface configuration and response of the pilot test..... | 75 |
| Figure 5.12 Layouts in divided pattern..... | 75 |
| Figure 5.13 The comparison of button proximity between normal and divided pattern layouts | 76 |
| Figure 5.14 The spatial discrimination of the button layouts in comparison with line layouts | 77 |
| Figure 5.15 The unstructured layouts | 77 |
| Figure 6.1 Structure of Chapter 6 showing sections and subsections for the overall study... | 79 |
| Figure 6.2 Experimental apparatus | 81 |
| Figure 6.3 Experimental protocol | 83 |
| Figure 6.4 Experimental setup | 83 |
| Figure 6.5 Samples of serial presentations of layouts for Experiment 1 | 87 |
| Figure 6.6 Illustrations of integration of spatial elements from four frames presentation..... | 89 |
| Figure 6.7 Line drawing outcomes in Experiment 1..... | 91 |
| Figure 6.8 Outcomes on button layouts in Experiment 1 | 93 |
| Figure 6.9 Layout ranking in Experiment 1..... | 97 |
| Figure 6.10 Interface layouts in Experiment 2..... | 98 |
| Figure 6.11 Line drawing outcomes in Experiment 2..... | 100 |
| Figure 6.12 Outcomes on button layouts in Experiment 2 | 103 |
| Figure 6.13 Grouping Information among Layouts Using Fisher LSD Method and 95% Confidence..... | 106 |
| Figure 6.14 Preferred layout ranking | 107 |
| Figure 6.15 Layout dimensions and relations | 111 |
| Figure 6.16 Design framework of eyes-free interface | 114 |
| Figure 7.1 The process flowchart of constructing the reversed L-shaped layout | 119 |
| Figure 7.2 The process flowchart of constructing the U-shaped layout | 120 |
| Figure 7.3 The process flowchart of constructing the underlined N-shaped layout | 121 |
| Figure 7.4 The overall process flowchart of designing the effective interface configurations in touchscreen eyes-free application..... | 123 |
| Figure 7.5 The examples of interface configurations | 124 |

| | |
|--|-----|
| Figure 7.6 The conventional formats of user interfaces and prototypes of eyes-free user interfaces | 126 |
| Figure 7.7 Study protocol on the first phase of eyes-free interface prototypes | 127 |
| Figure 7.8 Survey results among three types of layouts | 129 |
| Figure 7.9 Single-target selection tasks | 130 |
| Figure 7.10 Serial-target selection tasks | 130 |
| Figure 7.11 Study protocol on the second phase of eyes-free interface prototypes..... | 131 |
| Figure 7.12 The blank button layout used in the spatial memory test | 132 |
| Figure 7.13 The example of commands and tasks given in the test..... | 132 |
| Figure 7.14 Outcomes of all tests | 135 |
| Figure 7.15 Participants' feedback to interfaces after completing tasks..... | 137 |
| Figure 7.16 The participants' suggestions on the interface configurations | 138 |
| Figure 7.17 The illustrations of the ways to touch, reach and move the thumb when using the interface (Only the top row made an example with the visual interface) | 140 |
| Figure 7.18 Examples of adopting the middle segmentation feature..... | 148 |
| Figure 7.19 The updated flowchart based on expert feedback | 151 |
| Figure 8. 1 Summary of the work | 155 |

List of Tables

| | |
|--|-----|
| Table 2.1 Terminologies used in the sensorimotor system..... | 14 |
| Table 2.2 Terminologies used in the cognitive system..... | 15 |
| Table 2.3 Key themes of the reviewed papers on spatial interfaces | 31 |
| Table 3.1 The number of participants in studies..... | 43 |
| Table 4.1 Time set-up and variables for each trial..... | 50 |
| Table 4.2 The average of the net speed on each trial in Task 1 | 52 |
| Table 4.3 The average error rate (words/person) on each trial in Task 1 | 52 |
| Table 4.4 The cause of typing error in percentage..... | 53 |
| Table 4.5 The proportion of word error | 53 |
| Table 4.6 The average of the net speed on each trial in Task 2 | 54 |
| Table 4.7 The average error rate (pieces/person) on each trial in Task 2 | 54 |
| Table 4.8 The percentage of errors on jigsaw task | 55 |
| Table 4.9 Considerations on designing spatial interfaces for dexterous operations | 58 |
| Table 6.1 Errors in line drawing test on Set 3..... | 92 |
| Table 6.2 Mean distance error (units) of the unstructured layouts under serial presentation mode in Set 1 | 94 |
| Table 6.3 Mean distance error (units) of normal structure layouts in Set 2..... | 95 |
| Table 6.4 Mean distance error (units) of divided pattern layouts in Set 4..... | 96 |
| Table 6.5 The outcome trend and interquartile range of line drawing layouts | 102 |
| Table 6.6 Mean errors in line drawing..... | 102 |
| Table 6.7 Mean distance error (units) of the unstructured layouts in a unified layout or simultaneous presentation mode..... | 104 |
| Table 6.8 Mean distance error (units) of the normal layouts in Experiment 2 | 105 |
| Table 6.9 Mean distance error (units) of the divided pattern layouts in Experiment 2..... | 105 |
| Table 6.10 Characteristics of each layout..... | 111 |
| Table 7.1 Descriptive statistics of all tests..... | 134 |
| Table 7.2 The mean distance error (units) of buttons for the conventional and the new formats of arrow layouts | 136 |
| Table 7.3 The profiles of experienced user interface designers..... | 142 |

Chapter 1 Introduction

It is undeniable that the handheld device is ubiquitous and convenient (Weiss, 2002; Lorenz et al.,2009). These devices are used for entering information into the computer system with touch. Various examples of handheld devices are provided in Figure 1.1, such as a remote control, a Bluetooth clicker, a smartphone, and VR controllers. In the virtual reality system shown on the right of Figure 1.1, the user is wearing the headset and using the controller through tactual perception. That person uses the controller in the absence of vision but is able to control its function by physical buttons. Smartphones are one of the everyday handheld gadgets in the digital age. There were over 5 billion smartphone users from about 7.9 billion world population in 2020 (UNCTAD, 2021). People use them for many purposes and in various contexts, for example, visual search, menu selection, and functional control. With touchscreen technology, smartphones are different from other feature devices. Recently, some interactive system applications adopted a smartphone as a video game controller (AirConsole) in conjunction with Android TV and as a VR controller in conjunction with the headset (HTC Vive Flow) instead of the traditional haptic controller (Schoon, 2021). This mobile device communicates with the users via interfaces.



Figure 1.1 Handheld devices or controllers

The term ‘User Interface (UI)’ describes the device’s parts, including data display, data entry, or control interface (Sutcliffe, 1988), which users see and interact with in order to communicate with the technological systems such as computers, machines, touchscreen mobiles, and mixed reality systems. Based on the user's intention, the task result should be accomplished at the affordance of the product. In engineering design, affordance relates to the design of a product or visual interface in an intuitive approach so as to support users in performing certain actions on the product correctly (Andersen et al., 2021). In other words, users perceive how to perform an interaction easily without experimentation through the visual properties of a designed interface element. User experience is the primary concern for product

success in the interactive system. With interactive technology, the user interaction could be in many input modalities such as touch, gestures, voice, eye gaze, and brain waves (Peddie, 2017).

The field of human-computer interaction and user interface design relates to the study of human factors and ergonomics from physical parts of the body (anthropometrics) to behaviour aspects, cognition, and human information processing to control the interfaces (MacKenzie, 2012; Ritter et al., 2014). Figure 1.2 shows human-mobile interaction relating to the user interface. UI involves the input part whose device (task) is operated by the user and the output part which is the graphical display. Eyes and limbs play the major role of medium for perceiving the stimuli and feedback on the interface. The brain processes all of the information obtained from the human senses. Sight on visual representation contributes to human perception and memory. Then, the interpretation is executed, and the action is planned within the brain. Finally, actions are performed for the intended goal through limb control and sense of touch. As a result, the mobile device operates along with visual feedback provided to the user.

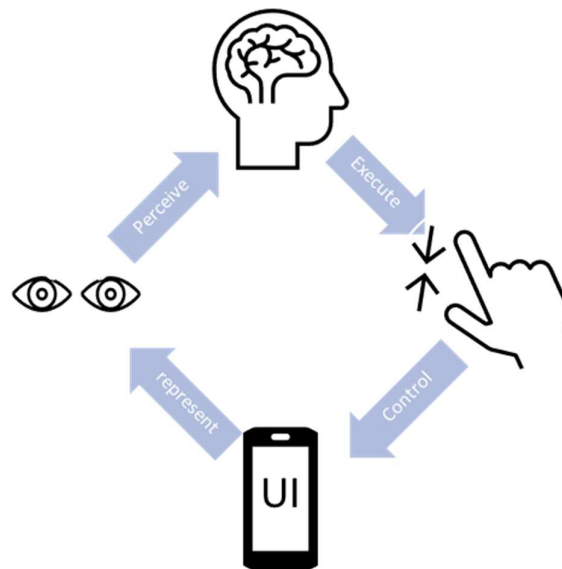

Figure 1.2 Human-Mobile Interaction (HMI) relating to User Interface (UI)

A touch screen interface supports rich interactions through various input types, including swipe, pinch, slide, tap, and press and hold. Bachynskyi et al. (2015) reported that using a smartphone with two hands provides better performance than one-handed use. However, the thumb interaction within a hand holding and operating the system could also be suitable when

it preserves a limited physical resource in the case that solely one hand is available, offers dexterous movement, and promotes multitasking (Mark, 2015). It is said that people usually operate mobile phones with one hand (Park and Han, 2010; Chen and Yan, 2016).

Mobile computing and applications are usable, easily accessible, and well-supported to users. The interface of the interactive system includes input and output modalities which are essential parts and influence human-computer interaction and task performance (Robelski, and Wischniewski, 2016). The interface features are composed of visual presentation and output feedback that relate to ergonomics design and interaction design (Zhao et al., 2007). Interaction on a mobile device might be the touch interaction on spatial interfaces such as virtual buttons, icons, or graphical objects, as well as the gesture interaction with a non-spatial interface i.e., abstract shape and pre-designed shortcut gestures (Poppinga et al., 2014). The design of functions and visual affordances could be integrated to facilitate and support users (Ciavola and Gershenson, 2016; Berni et al., 2020). This relates to affective, cognitive, and behavioural mechanisms (Crilly et al., 2004; Motamed, 2016). Many researchers and developers devote their attention to designing effective mobile interfaces (Hooper and Berkman, 2011; Medhi et al., 2011; Shao et al., 2015). The key size and location were considered as a major interest in ergonomic design (Punchoojit and Hongwarittorn, 2017). These are related to the physiology of the hand and fingers, affecting the performance accuracy of the interface. In addition, the studies of cognitive ability and visual information give designers insights into design characteristics to improve the performance of products in a wide variety of use cases (Henry, 1998; Rama, 2001; Jin et al., 2007; Andersen et al., 2021). However, some issues with mobile interaction still persist. Feng and Agosto (2017) addressed users' experience of mobile information overload. Users often felt information overload when using their smartphones.

Mobile interaction mostly is direct interaction with an interface that is displayed on the screen and requires the users to look at and interact with it. In other words, the mobile interface requires users' visual attention in order to locate and interact with the correct spatial position. Figure 1.3 illustrates smartphone usage in different contexts. People may use smartphones for listening to music while waiting for the bus, functioning as a navigator when driving, or paralleling to another interest or activity. As a result, users' attention would be switched forth and back between tasks. During multitasking, a user's eye attention may focus on the primary task and use the peripheral senses to perform the secondary task on a mobile device with less visual attention. For example, controlling a menu of a music player seems a secondary task while watching buses that are arriving. Interacting with a mobile device may become the centre

of attention when required but may also be performed in the periphery. As opposed to the products or artefacts that are rich in tactile qualities with physical buttons, operating a smartphone that is flat and featureless touchscreen without looking at them is challenging and interesting despite often being required when the user's attention is occupied by a primary task. In other words, the interactions with smartphone interfaces can act as a distraction from other activities which could put the user at risk. Should the user not have unique tactile cues on the touchscreen, they are forced to devote more attention to carrying out their task at hand. How good it would be if the touchscreen interfaces offer an effectively designed layout to facilitate eyes-free interaction.



Figure 1.3 Smartphone usage in different contexts

1.1 Motivation of the research

Since human mental resources and attention are limited and need to be allocated efficiently (Wickens, 2002; Bakker, 2013), the input interface should facilitate users to reduce their visual attention. Yi et al. (2012) pointed out that it would be beneficial if users could operate the mobile device in eyes-free mode to reduce visual attention from the many demanding tasks. The absence of any physical buttons (tactile cues) on the touchscreen implies that eyes-free interaction is not easily achieved. Some researchers applied reactive audio feedback to facilitate touch input techniques for eyes-free menu selection (Zhao et al, 2007; Vazquez-Alvarez and Brewster, 2011; Kajastila, 2013). Even voice-controlled functions like Siri in Apple's iPhone are available nowadays. Nevertheless, the problem might occur if there is background noise interference. It seems that the interaction with a non-spatial interface such as pre-defined shortcut gestures might lessen the need for visual attention. However, these abstract gestures are hidden controls, requiring a significant effort to remember and learn and there are still many possible difficulties to interpret a set of gesture commands accurately for the recognition system of drawn abstract shapes on a touchscreen (Poppinga et al., 2014). Punchoojit and Hongwarittorn (2017) provided that recent studies are insufficient to establish mobile interface design guidelines for eyes-free interaction. Therefore, it is interesting to explore designing touchscreen interfaces allowing a reduced level of visual attention. This

thesis will develop spatial interface configuration prototypes that are easy to remember and learn, and easy to reach and navigate in eyes-free mode.

Generally, the development of the interface relies on knowledge concerning computer science and human factors like the physiology of the human fingers and user psychology (Sutcliffe, 1988; Bergstrom-Lehtovirta and Oulasvirta, 2014, Mayer et al., 2017). Hand/finger characteristics and usage patterns vary from user to user (MacKenzie, 2012). To design an effective interface, it is required to perform empirical studies to understand human characteristics and user experience clearly. Therefore, researchers usually conduct experiments with participants so as to measure the interface performance and gain useful insights for a more well-refined design. Other researchers have reported undertaking similar activities albeit in different applications. The previous studies related to interface design, for example, the study by Roudaut et al. (2009), Dezfuli et al. (2012), Leitão and Silva (2012), Gilliot et al. (2014), Tao et al. (2019), and so on, examined different contexts such as adopting gesture shortcuts, interaction with the index finger, or design improvement on different form factors. Many interface studies reported that form factors, including target size, shape, location, direction, and proximity, influence the task accuracy and completion time for one-handed thumb interaction (Parhi et al., 2006; Park and Han, 2010; Lee et al., 2019; Tao et al., 2019). However, the previous studies in Human-Computer Interaction (HCI) have not dealt with the interface configurations or button alignment on touchscreen mobiles in the eyes-free mode.

This research investigates human cognition and task performance under the development of touchscreen interface configurations to increase the accessibility of mobile interfaces for eyes-free interaction. Two innate human abilities that are spatial memory and proprioception were highlighted as part of the research. Spatial memory refers to the cognitive ability to recall the visual-spatial layout, which was seen and remembered before, in order to interact on the interface efficiently without relying on visual feedback. Proprioception involves the brain's sense of limb movements or a person's ability to control a hand and manage a thumb aiming at the target in the absence of vision accurately. Eyes-free interaction involves tapping on the screen under human spatial recognition and proprioceptive sense. In other words, the spatial information of interface layout summarized in a cognitive map (memory), the spatial feedback received from the internal sense (human skin and subcutaneous tissues), and the external environment (frame of reference) are associated with taking precise action on a touchscreen. Under the spatial layout mapping process, spatial memory is integrated with proprioception in order to correctly interact on the mobile touchscreen by matching the spatial position in

relation to the imagery interface. If a person is able to accurately map positions on a spatial layout, then this could possibly lead to elimination of the need to visually confirm hand gestures.

Gustafson et al. (2011) found that spatial knowledge could be gained during regular use of the interface layout, and transferred to the imaginary interface. They introduced the Imaginary Phone, a non-visual interface in which users have transferred spatial memory of the learned interface, to the palm to enable pointing input on screen-less mobile devices. Tactile cues sensed by the interface on the palm, enable users to orient themselves effectively. Unfortunately, on-body (palm) touch interfaces require the tracking (sensing) of hardware and the modification of software. Although Gustafson et al. (2013) suggested that interfaces located on the human body outperform interfaces on physical devices, mobile interaction is easier to adapt the interface for eyes-free interaction without resorting to any additional sensors.

The flat, featureless nature of touchscreens is at odds with the way in which humans intuitively navigate the physical world. However, continuous human sensory input from navigation allows us to understand where things are in relation to the body–spatial proprioceptive awareness. By simplifying and summarizing layout patterns, and understanding how we can locate and memorise active touchpoints, there is an opportunity to create touchscreen interfaces that harness innate human abilities and product affordances, allowing reduced visual attention and voice-controlled functions or auditory interfaces. Therefore, this research will investigate the nature of eyes-free touchscreen interaction to understand the nature of spatial memory and proprioception in this context more deeply, through the development and evaluation of new interface configurations. The eyes-free interface could serve typical touchscreen users in performing a secondary task on the touchscreen. These contain touchscreen-based interfaces such as in-car devices, smartphones, and industrial machine control systems. The user group of such technologies could include those who are hard-of-hearing or visually impaired. The performance of eyes-free interaction would be improved by such interface configurations.

In the somatosensory system, the sense of touch consists of a cutaneous sense and kinesthesia (Ritter et al., 2014). Haptic perception provides information about objects and events in the environment by cutaneous stimulation and kinaesthetic sense concerning motion control. This continuous sensory input allows a person to understand where things are in relation to the body and environment. Through spatial proprioceptive awareness, a person can trust tactile perception (internal feedback) and skillfully interact with the surface and objects (Magill and

Anderson, 2017). The proprioceptive cues from the end effector (fingers) transmit the determination of relative position for response correctly (Worringham and Kerr, 2000).

This research, therefore, studies the characteristics of the interface on the dexterous operation and the role of interface configuration on eyes-free performance accuracy in touchscreen interaction. The proprioception contributes towards the movement control according to the spatial relationship while the spatial memory facilitates the planning process. The insight into the study of the role of imaginary interface configuration leads to the design framework and guidelines for eyes-free interface layouts. Although the scope of this thesis is to study on the mobile touchscreen context, the findings on spatial memory and proprioception may be applied to other touchscreen contexts such as on a remote control, a control panel, and a car dashboard.

The designs which facilitate human perception, cognition, and motoric properties promote efficient operation (Proctor and Vu, 2006). This research aims to observe, investigate, and test the human capability for various interface configurations so as to gain insights into designing an interface that could reduce visual and physical demands. These include avoiding visual attention to the interface and repositioning the hand.

1.2 Aim and objectives

This research aims to improve understanding of proprioception and spatial memory in order to deliver a framework and guidelines that can support effective eyes-free interface configurations for low feedback surfaces, e.g., for one-handed thumb interaction on a flat touchscreen mobile. Thus, the research has objectives to explore and examine interface characteristics to develop and validate the theoretical framework and practical guidelines for an eyes-free interface design.

1.3 Thesis structure

This thesis is organised into 8 chapters. Each chapter includes an overview and a summary to orient the readers and to broaden the scope of understanding. The thesis structure is outlined as follows:

Chapter 1: Introduction

This chapter shows the overview of user interfaces, problem statements, and research motivation. A broad overview of the literature was processed, then the research aim and scope were set out. This thesis will study spatial interfaces and focus on designing interface configurations to support touch screen eyes-free interaction relying on two innate human

abilities: spatial memory and proprioception. Any augmented feedback regarding the touchscreen interface will not be provided. The need for the intervention and justification for conducting the research is presented. The purpose of the thesis is well summarised with the research objectives. Finally, the outline of the thesis structure is provided.

Chapter 2: A literature review of researches on human factors in the interface and interaction design

This chapter reviews the literature critically, identifying the research gap and posing the research questions. Through a secondary literature review, the relevant topics on cognitive psychology and physiology to uncover the underlying mechanism of eyes-free interaction focusing on touch-based interaction were provided. As a result, spatial memory and proprioception were thoroughly explored. The relevant topics cover human cognitive ability, biomechanics of finger movement, human senses for target selection tasks, mobile interaction, and user interface design. These include key themes of the reviewed papers and the knowledge gaps that are discussed in touchscreen eyes-free interaction.

Chapter 3: Research approach

The chapter shows the research philosophy and research design utilised for each stage to achieve the aim and objectives of the study. The main stages consist of development of interface configuration prototypes, descriptive studies, and a prescriptive method. In this chapter, justification is presented for selecting the research methods or research techniques which contribute to empirical findings and theoretical foundation.

Chapter 4: Understanding human ability under spatial interfaces for dexterous operation

The chapter presents the preliminary study that enhances the understanding of the characteristics of the spatial interface. The experiment was conducted to comprehend the effect of time pressure (mental workload) on task performance regarding different spatial interfaces and explore in basic interface characteristics facilitating dexterous operations. The existing interfaces were tested to provide suggestions for design development. The chapter illustrates task design and approach, experimental procedures, participants, and findings. The results were discussed in performance analysis, error pattern, behaviour, and strategy on a spatial interface. This leads to the design research on spatial interfaces for eyes-free interaction.

Chapter 5: Interface Prototype development for eyes-free touchscreen interaction

This chapter starts with the description of the eyes-free interaction on a mobile touchscreen and shows the interface configuration factors impacting touchscreen eyes-free interaction.

Then the design methods for prototype development of eye-free interface layouts were proposed from the conceptual design to the detailed design. In addition, the development and operation of the prototype system (experimental apparatus) were described. As a result, the final prototypes of 15 layouts to be tested in experiments were derived.

Chapter 6: Understanding human spatial memory and proprioception on the eye-free interface to develop a design framework

This chapter consists of two experiments on spatial memory and proprioception. It starts with an experimental aim, experimental protocol, apparatuses, task and procedure, hypothesis, participants, data processing, and analysis method. The results include analysis of experimental data and hypothesis testing. A discussion was highlighted on the characteristics of interface configurations and performance accuracy. Finally, the design implications for an eyes-free interface were proposed with the theoretical framework.

Chapter 7: Design guideline development and validation of eyes-free interface design

This chapter presents the development of design guidelines and illustrates the design of eyes-free interface layouts and their evaluation for mobile practical use cases. Results from the experiment with users led to ways to effectively design an eye-free interface. The design guidelines for an eyes-free interface were constructed and refined by following the design framework. The theoretical framework developed in the previous chapter and design guidelines were reviewed by experienced user interface designers. The questionnaire, usability testing, and interview were associated to validate the practicality of the eyes-free interface. Finally, insights into designing eyes-free interface configurations have been obtained.

Chapter 8: Summary and Conclusions

This chapter identifies the outcomes of the research according to the aim and objectives of the study, key findings, and empirical and theoretical contributions. Limitations and recommendations for further research are also discussed.

1.4 Summary

This chapter introduces the overview of the user interface for human-mobile interaction, problem statements, research challenges, motivation, and the importance of this research. The research aim, and objectives were illustrated. In the end, the thesis structure was presented. This research studies the role of interface configurations on performance accuracy in eyes-free touchscreen interaction. The absence of any physical buttons (tactile cues) on the touchscreen

implies that eyes-free interaction is not easily achieved. The next chapter will present and discuss the review of relevant literature to explore the issues, develop ideas, identify knowledge gaps, and research questions. Moreover, it will provide sophisticated comprehension of human abilities in cognitive psychology and physiology, as well as the underlying mechanism of human-computer interaction for designing eyes-free interfaces. To create eyes-free touchscreen interfaces that harness innate human abilities and product affordances, spatial memory and proprioception were two areas that were highlighted.

Chapter 2 A literature review of researches on human factors in interface and interaction design

Based on the aim of the research, the core function of this chapter is to present and discuss the review of relevant literature to explore the issues, develop ideas, identify knowledge gaps, and research questions. Finally, it provides sophisticated comprehension of human abilities in cognitive psychology and physiology, as well as the underlying mechanism of human-computer interaction for designing eyes-free interfaces. Reviewing the literature forms parts of long works of research. It lays the foundation for researchers of human factors and improving the interface design focusing on touchscreen interaction for handheld devices. The design characteristics for mobile interaction are also explored. Considering all relevant research on a topic would be impractical given the limited time available. The next section will explain the derivation of each research question resulting from a critical review of the current state of knowledge on the research problem.

2.1 Background

The initial literature review in the introduction chapter resulted in providing the research motivation, aim and objectives. There is a research gap to create touchscreen interfaces that harness innate human abilities and product affordances, allowing the reduction of levels of visual attention, audio feedback or effort to remember, learn and navigate. This research focuses on the spatial interface configuration design for dexterous operation and touchscreen eyes-free interaction without resorting to any feedback with sound; therefore, this proposes the first two research questions for this thesis: what are the influencing factors in touchscreen eyes-free interaction? and what are interface characteristics promoting dexterous operation? Two innate human abilities that are spatial memory and proprioception were highlighted in this exploration. This user-centred design research targeted at the flat and featureless touchscreen interface to be subtly and ease of use under a reduced level of visual attention.

In order to answer these research questions, the relevant topics are reviewed and organised into six categories: human cognitive ability, human hand and control, spatial memory, proprioception, human senses for eyes-free interaction on target selection tasks, and mobile interaction and user interface design. These categories are clarified about human learning, memory and attention, biomechanics of finger movement, sensory system, human performance, interaction, and interface design. Key findings on spatial memory and proprioception including the knowledge gap are highlighted.

Overall, the research covers four main related fields of human-computer interaction, interface design, ergonomics, psychology of human behaviour, and user-centred design as shown in Figure 2.1. The focus of HCI is concerned with the ways computer systems should be designed and the ways they are actually used focusing on the interfaces between people and systems (Norman and Draper, 1986; Chakraborty et al.,2018). Interface design is come up with improving communication and interaction between the user and the computer. Ergonomics and psychology of human behaviour are related to the exploration of human cognitive processes and the behavioural interactions between the human body and the product interface. User-centred design is aimed at enhancing usability and performance for user needs.

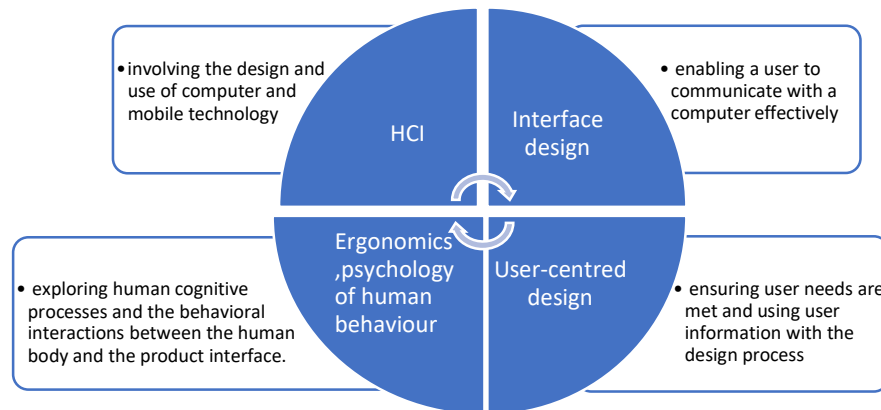

Figure 2.1 Field of research

2.2 Human cognitive ability

One of the key design principles is “placing people, the users, at the heart of any problem” (Design Council UK, 2013). Thus, it is vital as designers must concern users or people as fundamental. However, many products or services as they are exposed sometimes make them feel frustrated or insecure. This research applies to a user-centred design approach for improving user interface configurations. Human factors and ergonomics studies related to design are a multi-disciplinary approach considering the people using the products as a key factor in conjunction with designers and/or manufacturers. Steen (2011) argued that the tensions occur when the goal between two sides is not matched as it needs to be critically adapted and balanced among the knowledge and perceptions with the needs and practices for the design. Norros et al. (2015) stressed the role of design under believing that the design is a creation of new knowledge which is from comprehending the human in practice.

Humans perceive information from internal and external stimuli with their senses. Then the information is processed, coded, and possibly stored in individual memory (Sutcliffe,1988).

Memory ability is intertwined with attention. Some neuronal mechanisms for memory were proved to involve attention (Humphreys et al.,1999). David LaBerge (cited in Humphreys et al.,1999, p.35) suggested that directing visual attention to a spatial stimulus can lead to more rapid accurate discrimination of the information contained in that stimulus. Berthoz (2000) questioned the role of memory in the relationship between perception and action. He claimed that the predictive nature of perception is due to memory and demonstrates several types of memory i.e., declarative, implicit, working, episodic, procedural, short-term, long-term, spatial, semantic, lexical, topographic, motor, and even muscle memory. These are implemented in different parts of the brain because they share information and work together. Thanks to these analyses, spatial memory is considered as a pivotal factor in representing space. Paillard (cited in Berthoz, 2000, p.117) demonstrates that a sensorimotor mode of processing spatial information coexists with a representation mode which involves mental representations of local maps, spatial relationships of routes in connection with landmarks, relative positions between objects, including the position of the body itself in relation to its stationary environmental frame.

2.2.1 Understanding in human cognitive processes

To design an artefact and system for users effectively, it is essential to learn about human information processing systems. There are 3 main stages regarding human cognitive performance processes (Figure 2.2). This stage model directly shows voluntary control by responders such as fingers, limbs, and voice, regardless of consideration on another group with less under control or subtle control, which is autonomic nervous system (Bailey, 1982). Winfield (1986) proposed cognitive skill dimensions involving planning, perception, motor, and solving problems in accordance with task demands. These relate to the whole range of information processing capacity of the brain or memory system, consisting of encoding, storage, and retrieval. Task performance shows in the terms of response time and accuracy. Total response time is derived from typical time taken for sense receipt to operate, neural transmission to the brain of information, delays in mental processing from cognition and decision making, transmission of neural message to muscle, as well as muscle latency and activation time (Winfield, 1986). These use around 150 milliseconds to 700 milliseconds (nearly a second).

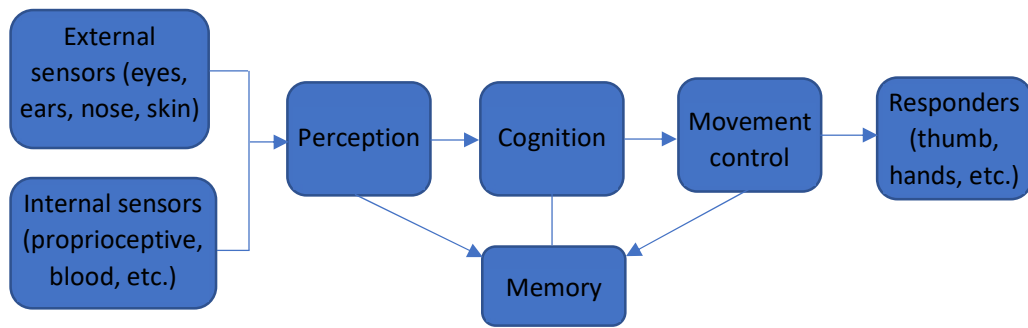

Figure 2.2 Human cognitive processes (Adapted from Bailey, 1982)

To understand human cognitive processes contributing to action and movement, the relevant terminology in cognitive neuroscience was explored in accordance with this research purpose on human-computer communication, interaction, and interface design. Lephart and Fu (2000), Kitchin and Freundschuh (2000), Eichenbaum (2002), and Dudchenko (2010) provide useful definitions of the neuroscience of spatial cognition and neuromuscular control which would be referred to in this research. As a result, the relevant terminologies are presented in the sensorimotor system and cognitive system, as shown in Table 2.1 and 2.2. These terms are referred to in the explanation of cognitive processes as follows.

Table 2.1 Terminologies used in the sensorimotor system

| Words | Definition |
|----------------------|--|
| Afferent pathways | pathways that are formed by neurons leading to the central nervous system (CNS) from sensory receptors. |
| Effector | the body part that reacts to a stimulus in a particular way. |
| Efferent pathways | pathways that are formed by neurons leading to an effector from the central nervous system (CNS). |
| Postural control | the ability to maintain control over posture that is automatic and task specific. It consists of (1) acquisition of afferent information from somatosensory, visual, and vestibular sources, (2) integration and processing of the afferent information by the CNS for selection and coordination of appropriate motor responses, and (3) execution of the motor commands by the musculoskeletal system. |
| Somatosensory system | the collection of peripheral sensory receptors responsible for giving rise to afferent information for perceptions of mechanoreceptive (tactile and proprioceptive), thermoreceptive, and pain sensations. |

Table 2.2 Terminologies used in the cognitive system

| Words | Definition |
|-------------------------------|---|
| Cognitive map | a stable Euclidean representation of the distances and direction between landmarks and locations. |
| Cognitive mapping | the process of forming internal spatial layouts of the environment that can be used in navigation. |
| Discrimination learning | tasks in which the subject is presented with multiple stimuli and must consistently select one of them and not select the other to obtain a reward. |
| Explicit memory | memory expression based on conscious recollection involving direct effort to access memories. |
| Exteroceptive | reception of stimulus information from the external world. |
| Implicit memory | Unconscious changes in performance of a task made while reperforming a task as influenced by some previous experience. |
| Inferential memory expression | the capacity to deduce solutions to novel problems based on indirect relations among items retrieved from distinct memories. |
| Semantic memory | the large-scale memories organisation or the body of one's world knowledge that a person acquires from every experience. |
| Navigation | landmarks recognition and knowledge of the spatial relationships between landmarks and the intended destination. |
| Procedural memory | a set of learning abilities that involves tuning and modifying the networks of many brain systems that support skilled performance. |
| Visuospatial | the location in space of visual stimuli. |
| Working memory | a combination of storing new incoming information, plus some type of cognitive manipulation, held over a brief period in consciousness. |

2.2.2 Mental Workload

Multiple resources theory shows that the human resource is limited but allocatable (Wickens, 2002). Typically, the visual and auditory resources are interfered with and competed among their relevant task demands. The amount of data processing of the brain or mental workload involves a level of attentional resources a person requires, resulting from task demands, external support, and individual experience (Young et al.,2015). It was suggested that mental workload should be appropriate because both mental underload and mental overload affect performance. Human attention involves a level of mental resources allocated to potential

activities (Bakker, 2013). The world around us is constantly full of stimuli that we can potentially attend to. Due to humans' mental resources and attention spans being limited, they need to be marshalled efficiently. Many factors could cause the increment of mental workload, for instance a rush from time availability decreasing, and a higher level of task challenges.

Generally, people are able to perceive a great amount of information from a visual display. The mental resources are, therefore, divided on potential information. The salience of a perceptual stimulus and the state of mind cause the resources to be allocated differently in the attentional processes (Wickens, 2002; Bakker, 2013). Moreover, in the digital age, people are continually subjected to visual information through various media. In the circumstance of dealing with time-shared tasks, spatial graphics presented concurrently lead to mental resources overloading since the user's attention is inhibited by visual representations.

It has become common for people to use mobile devices as a 'default' device that is constantly referred to, and often in multitasking situations (Feng and Agosto, 2017). This has the propensity to cause cognitive overload and mistakes in operation. On the touchscreen mobile, typical applications (e.g., music players, cameras, smartphones, and calculators) rely on a menu interface layout with several hierarchical layers and options that require dexterity and concentration to navigate (Figure 2.3). The existing mobile interfaces consume much visual attention and have an inappropriate spatial configuration that cannot be used without looking at. This means that even for short operations, the touch input still calls for users to look at the screen and switch attention from any parallels or primary tasks.



Figure 2.3 Mobile interfaces and menu interface layouts

Wickens (2002) and Young et al. (2015) suggested that providing performance feedback and reducing the number of available decision options help in reducing mental workload. Thus,

for the improvement of design, it is important to carefully consider the user's mental workload and the level of task performance in the environmental context.

2.3 Human hand and control

This section provides an overview of human hand function and behaviour, relating to human interaction on a mobile device. Hand manipulation and control could involve with or without visual feedback. The latter case would exploit spatial memory and proprioception, covered in the next section.

The human nervous system gives data about the mechanical forces of muscles, tendons, and joints from the stretch of fingers that cause the perception of the position and status of limbs in space (Hellier, 2016). The CNS employs the proprioceptive information for the regulation of neuromuscular control (Lephart and Fu, 2000). Motor control mechanisms can be categorised into either feedback or feedforward control models. The feedback mechanism is a reactive process lasting hundreds of milliseconds and providing a conscious appreciation of position and motion used for fine-tuning motor commands for precision movement (Tuthill and Azim, 2018). As a result, this process is devoted to maintaining posture and regulating normal movement. On the other hand, the feedforward mechanism utilises information from previous exposures to known conditions that are then integrated with ongoing proprioceptive information. Therefore, it is responsible for generating preprogrammed motor commands to achieve the desired outcome. These mechanisms are often integrated into multiple processes so coordinated motor skills are acquired (Lephart and Fu, 2000).

Jones and Lederman (2006) proposed the human hand function in four categories along the sensorimotor continuum. The primary functions of the hand include tactile sensing, active haptic sensing, prehension, and non-prehensile skilled movements. Tactile sensing interfaces the human hand and contact surface in stable conditions. While the other categories occur in active hand movement. Hand postures and gestures are changed as the task progresses. The hand skeleton is shown in Figure 2.4. The hand consists of 27 bones with 8 small bones at the wrist (carpals). Each finger contains 4 bones, except for the thumb which has 3 bones. Phalanges are the bones of fingers, above the palm (Behnke, 2006). Metacarpals are the palm part. The thumb has only one hinge between the distal phalanx and the proximal phalanx. The four fingers have two hinge joints between the distal phalanx and middle phalanx, and between the middle phalanx and proximal phalanx. The hinge joint is orthogonal to the bone axis which provides the extended or fold motion manner in one direction.

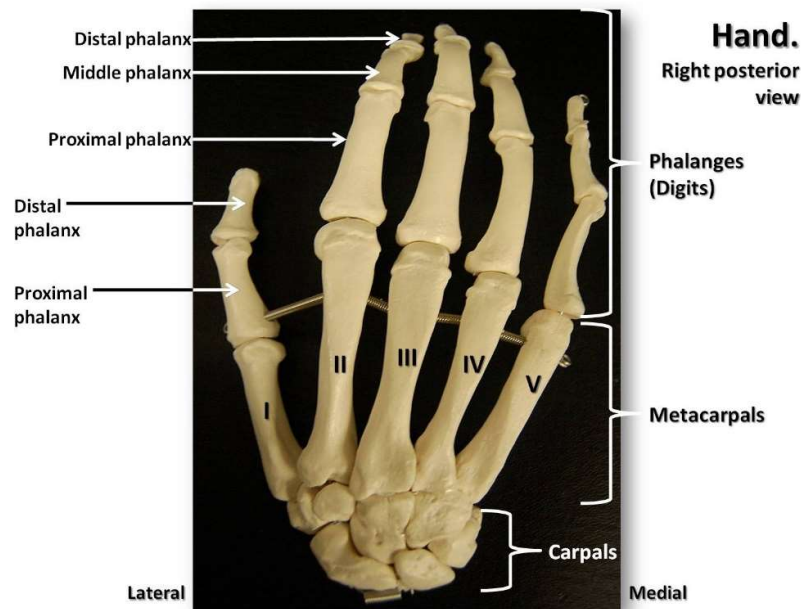

Figure 2.4 Hand bones

Source: Rob Swatski, <https://flic.kr/p/8owWBC> under an attribution-noncommercial share alike creative commons 3.0 licence.

The degrees of freedom (DoF) in hand joints influence the dexterity of finger movement and control. Cerruti et al. (2015) suggested that the hand posture indicates the degree of movement freedom of finger joint movement. The interactions when holding the device restrict possible movement. This implies that it could anchor the independent hand to the 2D plane under micro-interaction. In other words, the degrees of freedom of the hand reduces when grasping the object under a firm grip. Therefore, the interactions during the time of holding the device will provide better task accuracy. Mayer et al. (2018) pointed out that allowing the users to hold their mobile devices and to improve their postures makes the input easier to perform as opposed to the interactions on the tabletop screen. It was discovered that the thumb can turn and oppose all the fingers bringing about dexterity, so the thumb approach is often used for one-handed interaction. Figure 2.5 shows the degrees of freedom in each joint of the human hand.

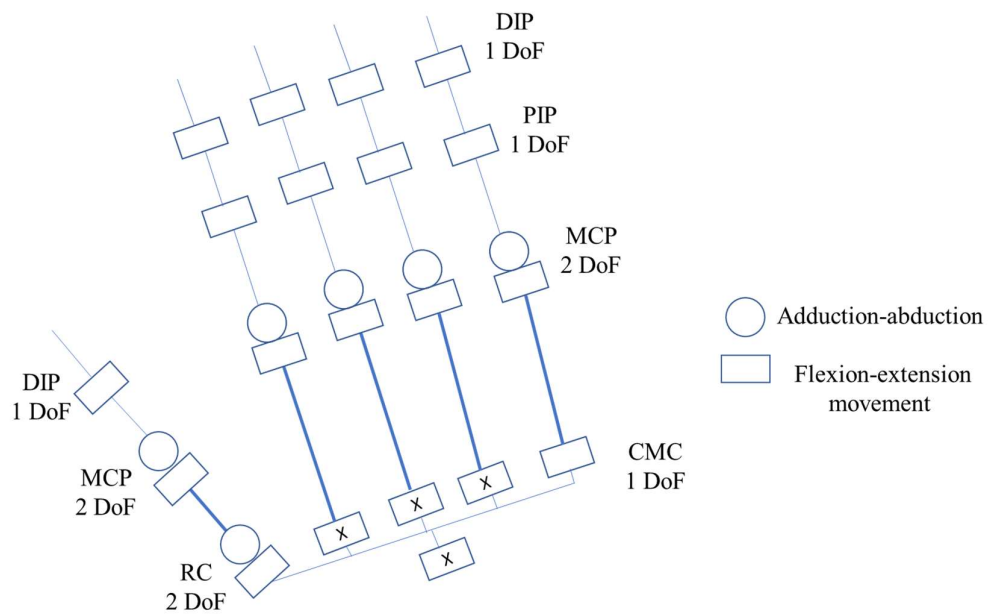

Figure 2.5 Top view of the back of the right hand (simplified kinematic model)

Although the thumb has fewer bones, it still possesses the same number of DoF as the other fingers in spite of a different distribution. The thumb has 5 DoFs from the hinge (1), condyloid (2), and saddle (2) joints, allowing flexion-extension, abduction-adduction, and opposition gesture (Rosenbaum, 2010). To exemplify, 1 DoF (flexion-extension) happens at the distal interphalangeal joint (DIP), 2DoFs are supported by the metacarpophalangeal joint (MCP), and 2 DoFs are supported by the radiocarpal joint (RC). The metacarpophalangeal joint (MCP) forms the knuckle of the thumb which can move more independently (2 DoFs). In one-handed thumb interaction, the users are holding the mobile within a hand and using the thumb as an interacting finger while its palm and other fingers are supporting the phone. This posture provides many tactile cues both on the palm and fingers. Figure 2.6 shows the kinetic anatomy under single-handed thumb posture with the degrees of freedom in respect of the related joints. Various gestures are caused by anatomical motions produced from joints (Kerr and Rowe, 2019) such as flexion-adduction or folding, extension-adduction, or swiping radially.

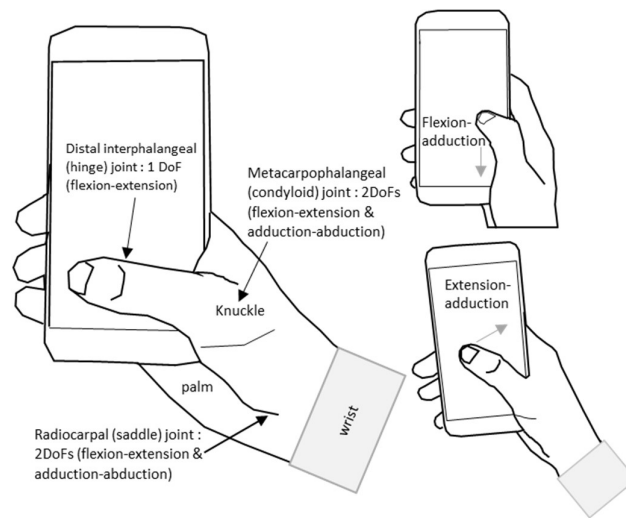

Figure 2.6 Kinetic anatomy and finger postures under single-handed thumb interaction

The analysis of finger posture and movement in biomechanics provides an insight that the flexor muscles of the hand and fingers are stronger than the extensor muscles. The evidence raised by Li and Goitz (2003) shows that the maximum amount of force generated in the thumb movement is ranked from flexion, abduction, adduction, and extension, respectively.

The flat pitch angles in the comfort zone and steep angles (higher pitch angle) in the non-comfort zones are the common and natural finger gestures with the mobile screen area (Mayer et al., 2017). It was found that interaction approaches differ amongst the population, depending on the hand and mobile size as well as the kind of task. In this research, the interface configurations are explored, which make it easy to perform an action with one's (right) thumb and to minimise the change of the stable hand grip under eyes-free interaction.

There are a number of factors such as directions, orientations, and finger angles, that affect the contact size of a finger on the screen and the target selection accuracy (Boring et al., 2012). These have been quantified as finger yaw, pitch, and roll (Xu et al., 2012; Umami et al., 2016; Le et al., 2019). The thumb, particularly in one-handed thumb use, will have a limited operational range due to holding the mobile. Bergström-Lehtovirta and Oulasvirta (2014) proposed that the thumb functional area on a touchscreen for a one-handed posture can be predicted by inputting parameters that describe the device dimension, grip, and hand size. This area is restricted within a parabolic curve whose range depends on the distance of the index fingertip from the device edge. Users need to orient and adapt their finger gestures to the touchscreen interface with a power of grip.

2.4 Spatial memory (SM)

Spatial memory is the cognitive ability to recall the representation of object positions that relate to a landmark and a frame of reference, or spatial layout (Thomas, 2010). It is associated with structuring and remembering the configuration or geometric properties of objects such as size, shape, distance, and coordinate location in a cognitive map. Structured patterns provide a visual cue that facilitates recognition (Vandierendonck and Szmalec, 2011). Proximity is another Gestalt factor that enhances visual perception and recognition performance. A group created from nearby objects or alignment tends to be processed together. Kitchin and Friendschuh (2000) asserted in their study that spatial cueing from many local cues such as spatial information of coastline and road network provides more accuracy in locating cities because respondents could grab their configurational knowledge on a spatial framework with familiarity. To specify the position of a target, a person needs an anchor point or frame of reference. There are two types of reference frames: egocentric and allocentric (Thomas, 2010). Egocentric frames of reference specify the location and orientation of a target near a person or in the peripersonal space. Allocentric frames of reference use environment elements and features to specify the location and orientation (inter-object relation).

Human memory involves with learning, retention, and remembering. These processes are affected by many factors such as age, gender, general intelligence, and educational level (Shikhman, 2007). Visuospatial working memory seems to be recalled better for the representation of four objects (Vandierendonck and Szmalec, 2011). Human beings have an instinct to detect symmetry. The stimuli that are symmetrical along the vertical axis provide a better recall than those in horizontal and diagonal symmetry (Royer, 1981). Furthermore, the mode of presentation is important to the spatial working memory. Simultaneous presentation is more advantageous to human recall and recognition than serial presentation (Vandierendonck and Szmalec, 2011).

Smirni et al. (1983) suggested that spatial memory performance depends on path length and path characteristics (sequences). To facilitate the working memory, the path length should be short, and the choice of the paths should be familiar and logical. Cattaneo et al. (2010) asserted the effect of visual experience regarding the spatial conceptualization. They found that the sighted people have better memory on the vertical symmetry than the horizontal symmetry as opposed to the visually impaired who have no effect.

A screen is an important component for spatial interaction as it provides the reference frame to users (Gustafson et al.,2010). The frame provides a spatial cue to the users. Gustafson et.al

(2010) conveyed that the shorter distance from the landmark, the more accuracy to acquire targets when there is no visual feedback provided. Gustafson et.al (2011) examined the human learning that was automatically transferred from the routine use of mobile. They found that a frequency of use leads to spatial learning and develops into spatial memory. Jetter et al. (2012) found that spatial memory performance suits better for the touch input compared to the mouse input. It is presented that direct touch input facilitates the encoding of object locations in the users' mental representation. This relates to proprioceptive cues and muscle feedback.

User interface design is concerned with the link between spatial memory and spatial behaviour. Gustafson et al. (2011) studied the spatial memory users built up from their regular use of spatial interface on their touchscreen mobile, and discovered that the amount of icons users could recall was approximately 4-16 icons from 20 icons on their phone's home screen on the basis of daily and weekly usage. Moreover, the participants could recall and map the locations on their phones to locations on their palms (Imaginary Phone) effectively although their palms scale 1.86 times from their touchscreen size. Figure 2.7 summarises the factors that influence the performance of spatial memory. Spatial memory ability depends on personal qualities and object qualities as well.

| Personal qualities | Object qualities |
|---|--|
| <ul style="list-style-type: none"> • age, gender, general intelligence and educational level • familiarity with secondary sources e.g., map • routine use (direct touch) • anchor point (body part) | <ul style="list-style-type: none"> • target location in relation to landmarks and reference frame • mode of presentation • configuration of targets, i.e. symmetry, alignment, proximity, structure, sequence, the number of targets, target size and shape |

Figure 2.7 Factors that influence spatial memory

2.5 Proprioception (PP)

Proprioception is generally referred to as the sense of position in space and velocity of displacement (Berthoz, 2000). It provides information of the body position and movement from static and dynamic limbs, allowing a person to know the location and orientation of the body parts. Besides, it is claimed as the sixth sense and critical to human experience apart from five basic senses (touch, sight, hearing, smell, and taste). People who lose it would not be able to coordinate the movements into purposeful actions to interact with the world unless relying on visual control (Tuthill and Azim, 2018). The main functions of proprioception are evaluated

upon the detection of position and motion through discrimination tasks. These include the threshold amount of motion, speed, and direction of motion. Position copying or position matching tasks are usually used for measuring proprioception both actively and passively (Hillier et al., 2015). However, there is abundant evidence that proprioceptive precision in active movement is higher than that in passive movements (Fuentes and Bastian, 2010; Tuthill and Azim, 2018). Thus, navigating across an object or active movement offering a tactile perception would lead to more precision.

Under the proprioceptive system, proprioception has been described by Charles Sherrington as the afferent information from proprioceptors located in the joints, muscles, and tendons that contributes to conscious sensations (muscle sense), total posture (postural equilibrium), and segmental posture (joint stability) (Lephart and Fu, 2000). Sensory receptors from neuromuscular spindles detecting for muscle stretch are incorporated with tactile sensitivity from touch in the exteroceptive field being transmitted to the brain for dynamic interaction. Tactile feedback provides useful information concerning skin deformation and contact points with an object (Tuthill and Azim, 2018). Therefore, it contributes to joint position and motion sense (Hillier et al., 2015). Concisely stated, the central nervous system (CNS) uses the cutaneous input as proprioceptive cues in order to control movement to achieve some goal (Lephart and Fu, 2000).

The degree of muscle stretch (flexion and extension) from static and dynamic limbs is signalled internally from the muscle spindles to encode kinematic information that the brain uses to control and correct movement (Leonard,1998). Golgi tendon organs encode muscle force or the load on a limb while receptors on the joint working with the tactile system detect the threshold limit, responding to the sensation of pain (Tuthill and Azim, 2018). The neural process integrating the sensory signal in the joint and muscle of the limb as well as the cutaneous/subcutaneous systems sends information to the central nervous system. Simultaneously, the motor neurons pass neural impulses from the central nervous system to skeletal muscle fibres in order to control the movement. Figure 2.8 shows the motor control pathways that connect the human brain system to body and limb movements. In brief, the central nervous system (CNS) functions as the “command centre” of human behaviours to motor control (Magill and Anderson,2017). Many brain systems contribute to thinking, memorising, concentrating, deciding, motor controlling, etc.

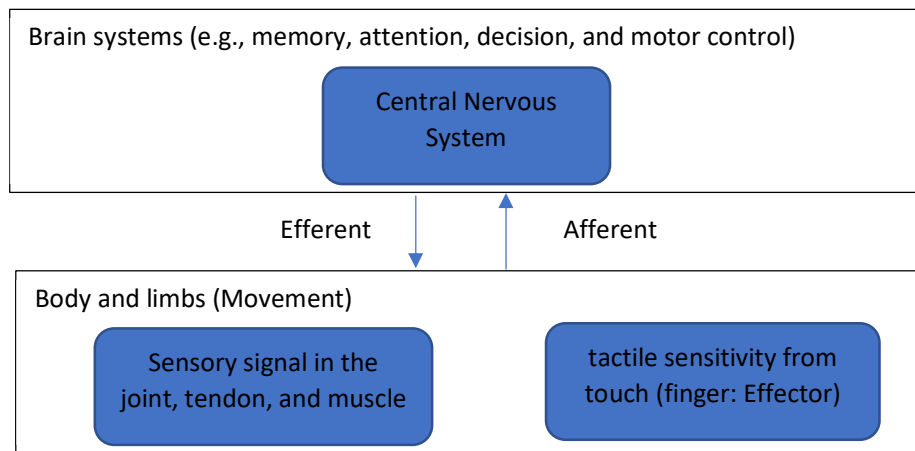

Figure 2.8 Motor control pathways in interacting with manipulable object under proprioceptive system, contributing to eyes-free interaction

Signals from the mechanosensory system are amplified, computed, and transmitted to the brain (Purves, 2013). The coordination of these systems ascending to and descending from the brain provides basic movements and postural control, contributing to eyes-free interaction. In the absence of visual control, the sensory system offers the body's spatial position information consistently to guide and control motor actions effectively. Finally, the accuracy and precision of that information are improved through information fusion (Fuentes and Bastian, 2010).

Spatial acuity has been defined as the ability to judge the target's position at its relative distance. People can discriminate the distance between two points within a certain range (Purves and Williams, 2001). For example, humans have a mean two-pointed discrimination threshold on their calf and thigh around 45 mm. while the thumb and fingers have a threshold of about 5 mm. Performance is slightly different among fingers. This is better than other parts of the body. Acuity to discriminate spatial detail starts from about 0.5 mm. in the small receptor field and from about 7 mm. in the large receptor field.

Crowe et al. (1987) investigated the proprioceptive accuracy of arm movements in two dimensions of individual target points under a configuration without visual cues. The result showed that the index finger displacement occurred more in the left for the right hand movement and occurred more in the right for the left hand movement. In addition, moving with the dominant hand is more accurate than the non-dominant one, and the adult produces a more precise response than the children do. Fuentes and Bastian (2010) examined the sense of limb position and discovered that the brain has better access to limb endpoint position than angles of joint. Lin et al. (2011) illustrated that in point division and tapping tasks on the forearm, the anchor points on the edge (the elbow and wrist) offer good proprioceptive

accuracy and the accuracy deteriorates with distance from the referred anchor point. Moreover, the accuracy rates differ among interaction techniques. The sliding-through method provides better accuracy rates compared with direct tapping.

With a lack of visual sense, proprioception plays the main role in perception and action. van Beers et al. (2002) claimed that users are more precise in localising a target in-depth and less precise in azimuth. These findings confirmed the performance of arm movements with index fingertips to the target. Nevertheless, there are not many studies researching proprioceptive accuracy of finger movement on a small screen, and therefore there is little knowledge related to thumb proprioceptive ability when interacting on the flat touch screen device. Finger posture would impact an input range (Mayer et al., 2017). In addition, awkward hand postures lead to less precision, more fatigue, and insecure grip of the device (Boring et al., 2012).

Gilliot et al. (2014) studied the impact of form factors on absolute indirect interaction with touchpads by the index finger both in blindfolded and sighted interactions. They stressed that the boundaries of the surface are important for proprioception, and asserted that indirect touch performance on the on-screen workspace does not matter on the display scale but does on the aspect ratio. Thus, the input and output aspect ratio should be similar. Moreover, they showed that the finger orientation and direction toward the tapping areas impact the success rate and accuracy, and pointed out that the target positions located at the centre and in the corners are easy-to-select areas. For right-handed people, they need to fold their fingers for the south-east position while they are not required to do so for the north-west position where the tapping area is easily accessible. Besides the position-based tapping area, the target size is proposed so as to gain better performance on the touch input device.

Gustafson et al. (2013) researched the role of visual and tactile cues when interacting on the spatial interface under proprioceptive sense with the index finger. They found that layout familiarity and spatial memory of interface configuration put forward the navigation performance both in blindfolded and sighted interactions. Factors affecting proprioception are summarised in Figure 2.9. The previous studies concerning proprioception have not dealt with mobile touchscreen interaction with the one-handed thumb posture. Additionally, thumb interaction is popular and offers dexterous movement, and promotes multitasking (Mark, 2015). For this reason, this research aims to explore the role of spatial layout on spatial memory and proprioceptive performance under one-handed thumb interaction on a mobile touchscreen.

| Personal qualities | Object qualities |
|--|---|
| <ul style="list-style-type: none"> • dominant hand • interacting finger and posture • age • finger orientation and direction • interaction techniques | <ul style="list-style-type: none"> • target size • input and output aspect ratio • target distance from the end joint and its location in relation to the frame of reference • tactile cues • configuration of targets |

Figure 2.9 Factors that affect the proprioception

2.6 Human senses for eyes-free interaction on target selection tasks

In many movement activities in real life, people sometimes recognise and harness the fixed spatial position of a target and reach it instinctively with less visual attention, e.g., turn on the light switch in the dark room by moving the arm and hand sensibly in the predetermined distance with proprioception to a specific location. In addition, they can act competently from familiarity that relates to spatial memory. Considering feedback-based timing, many interactions occur under an open-loop feedback system without visual perception (Rosenbaum, 2010). Due to the movement control centre in the central nervous system and the effectors (fingers) communicating effectively, humans can trust their actions through sensory feedback and thus they can operate devices very skillfully (Magill and Anderson, 2017). Dobbstein et al. (2017) introduced a wearable subtle touch interface for controlling smart eyewear indirectly by leveraging proprioception. Although the PocketThumb is not designed for eyes-free usage as it needs to be used along with a visual interface of smart eyewear, the interface seems to be easy to learn and may be controlled in an eyes-free manner under user memory and experience.

The concept of a frame of reference is tied to the concept of space and spatial cognition. There are several ways to present the position of objects. The egocentric frame of reference is encoding objects' position related to yourself. Another way of encoding spatial relationships would be the allocentric frame of reference. This is to use the relationships between the objects themselves or relate them to a frame of reference external to your body. Berthoz (2000) argued that the brain constructs a series of reference frames for each phase of the same movement. In addition, a person constructs a point of reference based on the relationship of the body parts. Gilliot et al. (2014) addressed that the larger device size leads to poorer accuracy, and folding the finger for reaching the targets leads to higher risk in targeting error. Huang et al. (2016)

presented that tapping in eyes-free interaction is more comfortable than drawing stroke, and the decreased accuracy of touch results from increasing the number of buttons on the layout. Moreover, they claimed that the thumb in the inward movement brings about higher physical efforts than the outward movement. This could imply the comfortable area of the thumb.

The sense of space also depends on remembered information (Groh, 2014). Thus, it is possible that the task accuracy will vary among proprioception and vision, based on the direction. van Beers et al (2002) claimed that, in relation to an eye angle, proprioception precision increases in the depth direction while vision ability increases in the horizontal direction. Lin et al (2011) illustrated the users' behaviour in tapping tasks and found that the sliding through method generates the highest overall accuracy rate. This confirms that movement for navigation is important to task achievement. It is related to position adjustment and provides spatial perception to the performer.

Michael A. Arbib (cited in Berthoz, 2000, p.110) expressed that 'perception is action-oriented, combining current stimuli and stored knowledge to determine a course of action appropriate to the task at hand.' Proprioceptive feedback is used to estimate distance and navigate when visual cues are unavailable (Tuthill and Azim, 2018). There are three phases of the goal-directed limb movement. It is started with control policy selection from the brain to reach the desired position. The suitable strategy results from a state estimate of the limb under bodily sense. The second stage is to refine motor output with online corrections by predicting outcomes under rapid movement and adjusting the control policy when necessary. The last phase would be sensorimotor adaptation under experience, repetition, and practice contribution to greater precision and accommodating changing conditions.

Nicholai A. Bernstein (cited in Berthoz, 2000, p.141) highlighted that the coordination of a movement is the process of mastering redundant degrees of freedom of the moving organ or making it a controllable system. Spatial memory contributes to perception and movement (Berthoz, 2000). In the same way, spatial cognition depends on sensation, perception, and memory, which determine actions. Landmarks and external cues aid orientation and spatial memory, so they guide spatial behaviour (Dudchenko,2010). Landmarks are used to provide spatial cues around which other information is anchored (Kitchin and Freundschuh, 2000). Anchor points become organising elements of the representation because of their salience, functioning as retrieval cues to access other elements. Berthoz (2000) claimed that the frame of reference used by the brain is relative to the relationships between fingers that are about to grasp the object. Moreover, he reported that the brain analyses visual inputs with respect to

three properties that consist of position, size, and orientation. However, these findings are in the various contexts which are not for the touchscreen mobile. In this research, these aspects of objects are explored for spatial memory and proprioception ability on the touchscreen mobile in the absence of vision.

Recollection, the familiarity with events, and knowledge about the world bring about declarative memory (explicit memory) under the consciousness while motor skills, associations, priming cues, and problem-solving skills are related to non-declarative memory or implicit memory (Purves, 2013). Simultaneously, the neural processes are behind behavioural functions including attention, recognition, integration, planning, selection, and execution. It can be assumed that manipulation in eyes-free mode results from the cognitive processes under the coordination of spatial memory and proprioceptive sense or the sensorimotor system (mind and body). Information retrieved from spatial memory (explicit memory) informs about the target position and contributes to motor planning and postural set. The accurate movement requires information about the limb position in relation to the objects and the body's position under proprioceptive processes. Landmarks and anchor points are useful and important clues for eyes-free interaction. These cause accurate target selection under eyes-free interaction. In addition, muscle memory referred from proprioception and transferred with practice and experience can support eyes-free interaction (Lu et al., 2017). Therefore, landmarks are an important consideration in touchscreen eyes-free interaction.

2.7 Mobile interaction and user interface design

There are many approaches to holding a mobile phone and interacting with its touchscreen (e.g., one-handed, two-handed, cradling). Obviously, most people often use a single-handed approach and interact with the thumb (Le et al., 2019). Trudeau et al. (2012) convinced that outward movement direction provides a better performance than inward movement direction. In 2015, Ng et al. suggested in their study that tapping provides better accuracy, in contrast to dragging.

A gesture can be flexibly changed due to mobile interaction at different screen locations. Under a limited thumb reach, users often grasp a phone in a variety of positions to provide a range of input areas according to the task (Le et al., 2018). A finger posture is adopted with the thumb movement to interact with the spatial position on the interface. Most touchscreen interactions require a tap on the screen so as to activate a function from the user interface. In this mode, the user's finger touches a spatial position briefly and is then withdrawn. A thumb contact patch can vary in size and shape, depending on the finger gesture (Umami et al., 2016). Xu et

al. (2012) explained the factors relating to unintentional displacement consist of the finger posture, target size and location, and target selection techniques. Pietroszek and Lank (2012) found that spatial correspondence targeting, mapped from a viewport to relative position within touchscreen devices, has a doubled percentage of errors from traditional targeting on a target visible input device, and the size of the target has no effect on the distribution of tapped positions.

For with-sight use (looking at the screen), Henze et al. (2011) found that the most accurate area is around the screen centre, whereas the edges and corners are the least accurate. This is in contrast with the result of Perry and Hourcade (2008) who suggested that the centre of screen is easy and comfortable to reach and tap but the target on the edge of the screen offers the best accuracy. Therefore, users' characteristics and the layout configuration should be carefully considered in designing the mobile interface. With the research findings on the existing visual interface, the touch target size for smartphones should be 6–15 mm while the spacing between targets should be 8–10 mm in order to avoid interference errors (Parhi et al., 2006; Hooper, 2011; Leitão and Silva, 2012). Figure 2.10 shows some examples of icon sizes and spacing sizes in the home screen menu and mobile application. However, very few studies provide design guidelines about the target size or performance accuracy in an eyes-free interaction. Gilliot et al. (2014) provided some minimum target sizes on the tabletop touch surface using the index finger under different input conditions of participants such as one hand without a vision blocker, one hand and two hands with a vision blocker.

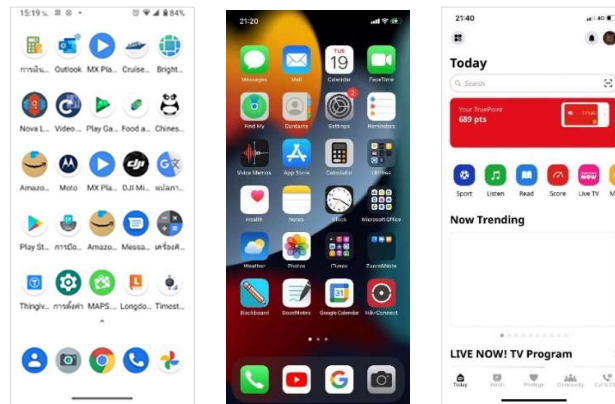

Figure 2.10 Icon size and spacing in the home screen menu and mobile application

Designing interfaces could effectively support human perception and good interaction (McKay, 2013). The visual and physical features of the interface involve its form, number, and spatial configuration (Ciavola and Gershenson, 2016). Few studies devoted to configuration design. The interface configuration or layout involves the target's sizes,

positions, and their relation. Fitt's law explained an effect related to the distance and size of the targets to the movement time (MacKenzie, 1995). Small targets and long distances increase the difficulty of a task and the movement time. Human perception of the interface configuration causes underlying motor processes. Similarly, interface configuration contributes to performance accuracy (Zhao et al., 2017). In addition to a target position and size, the input condition, for instance one hand or two hands and with/without vision, influences the task performance. Perry and Hourcade (2008) suggested that using the preferred hand provides better performance in response time and accuracy than the non-preferred hand. Gilliot et al. (2014) found that task performance based on proprioception deteriorates up to 20% with at least a 3-mm targeting error on the touchpad for a pointing task using the index finger. They also suggested that the aspect ratio is another important factor in task performance, the visual display and input surface should consequently have a similar aspect ratio.

Several eyes-free interaction studies set out to use interfaces on different interaction areas, including a touchscreen or a body part, e.g., the palm, the finger, and the forearm (Lin et al., 2011; Dezfuli et al., 2012; Yoon et al., 2016; Lu et al., 2017). These have different advantages and disadvantages. Unlike on-human body interfaces or cutaneous space, the touchscreen interfaces have no extra tactile cues available for improving interaction (Gustafson et al., 2013). In addition, there are relatively few studies examining the design of a touchscreen configuration by leveraging spatial memory and proprioception for one-handed thumb input. Dezfuli et al. (2012) presented the index finger interaction with one-dimensional grid menus containing a maximum of four options which provides good performance on the palm surface. They claimed that the vertical and horizontal 1D grid patterns provide similar performance accuracy. The accuracy rate depends on the position and the number of targets to be discriminated against. Lin et al. (2011) suggested that the interface for eyes-free use on the forearm should not contain more than 5 divided positions. The quantity of targets affects the spacing between targets, leading to different accuracy rates. Lin et al. (2011) expected that the middle point could play a critical reference point. However, they found that the level with odd numbers on the proprioceptive study at the forearm was not much different from the even number of points. Wang and Ren (2009) explained that an orientation vector consists of a direction and an angle from a point of reference. Finger orientation is a cue to further enrich the interaction on touch surfaces. They, therefore, proposed the exploitation of finger orientation (yaw angles) on a tabletop interface and presented a sector menu. In addition to the pointing task, eyes-free interaction involves gestures, including drawing marks. Rouduat et al. (2009) argued that gestures provide more accurate and quicker responses. A stroke gesture to

the target provides better performance than a discrete touch. Moreover, they found that symmetry of the menu supports interface learning and effective finger interaction.

It is found that custom menus can enhance users' experience and memory. Customisation involves moving items around an interface to reflect the users' priorities. User-defined interfaces are therefore considered to be easy to remember (Nacenta et al.,2013). According to Poppinga et al. (2014), it is also concluded that user-defined gestures could be more easily memorised than pre-designed gestures. Thus, allowing customisation would assist in better memory recall. Indeed, touchscreen interaction could be the spatial tapping or the gesture input. Effective interface configuration design should facilitate user perception, cognition, and response.

2.8 Discussion

In this section, key themes on touch-based interaction and user interface design identified from the literature are combined in a table format (Table 2.3). Researches relating to auditory interfaces and abstract gesture controls were not included in the table since the literature review was focused solely on spatial interfaces. As a result, the knowledge gaps appear and discuss as follows:

Table 2.3 Key themes of the reviewed papers on spatial interfaces

| Paper | Interface | Interacting finger | Human abilities | Independent variables | Application |
|---------------------|--------------------|--------------------|---------------------|-----------------------|---|
| Parhi et al. (2006) | Mobile touchscreen | Thumb | Direct manipulation | Target size, tasks | Optimal target sizes for one-handed use of mobile touchscreen |
| Wang et al. (2009) | Tabletop | Index | Direct manipulation | Orientation angle | Interaction techniques that make efficient use of orientation angle |

| Paper | Interface | Interacting finger | Human abilities | Independent variables | Application |
|-------------------------|-----------------------|--------------------|-----------------|---|--|
| Roudaut et al. (2009) | Mobile touchscreen | Thumb | Spatial memory | Linear Menus | Gesture shortcuts |
| Gustafson et al. (2011) | Palm (on-body device) | Index | Spatial memory | Target location | Imaginary Phone |
| Dezfuli et al. (2012) | Palm (on-body device) | Index | Proprioception | Landmark location, on-screen layout | Imaginary Palm-based Remote Control for Eyes-free Television Interaction |
| Gilliot et al. (2014) | Touchpad | Index | Proprioception | Device size, target position, input mode, display sizes and aspect ratios | Absolute indirect touch pointing tasks |
| Lin et al. (2014) | Forearm | Index | Proprioception | The number of targets, landmark location, tapping method | Point Upon Body interface |
| Yoon et al. (2016) | Index finger | Thumb | Proprioception | Input device, task | Wearable textile input device for eyes-free interaction |

| Paper | Interface | Interacting finger | Human abilities | Independent variables | Application |
|---------------------------|-------------------------------------|--------------------|---------------------|---------------------------------|--|
| Dobbelstein et al. (2017) | Wearable Dual-Sided Touch Interface | Thumb | Proprioception | Interaction technique, mobility | PocketThumb |
| Mayer et al. (2018) | Mobile touchscreen | Index | Direct manipulation | Pitch and yaw angle, hand | Finger orientation input for two-handed smartphone |

Although a number of studies have been conducted on interface design and eyes-free interaction, three knowledge gaps have been identified that this research will address:

1. The lack of examining the effect of different spatial interfaces that take advantages on spatial memory and/or proprioception. Chapter 4 of this thesis will examine two types of spatial interfaces for dexterous operation and answer the second research question about interface characteristics promoting dexterous operation.

2. The lack of studies that explore interface configuration for one-handed thumb interaction on touchscreen interfaces exploiting both spatial memory and proprioception. As a result, there is the opportunity to examine the spatial interface design for touchscreen eyes-free interaction. This issue introduces the third research question: What interface configurations offer better performance accuracy for touchscreen eyes-free interaction? Chapter 5 of this thesis will propose the prototypes of eyes-free interface configurations, impacting both spatial memory and proprioception (the influencing factors in touch screen eyes-free interaction were reviewed in this chapter). Then, Chapter 6 will focus on examining the effect of interface configurations regarding performance accuracy. The answer to this question could deliver a design framework supporting non-visual interaction for low feedback surfaces.

3. The lack of mobile interface design guidelines for eyes-free interaction proposes the fourth and final research question: How do we support the practitioner in designing the eyes-free interface to attain high accuracy and efficiency? Chapter 7 of this thesis will establish design guidelines that can help make eyes-free interface configuration effective for one-handed thumb interaction on a flat touch screen mobile.

In order to fulfil the research aim (to improve understanding of proprioception and spatial memory in order to deliver a framework and guidelines that can support effective eyes-free interface configurations for low feedback surfaces), four research questions were summarised as follows:

What are the influencing factors in touchscreen eyes-free interaction? (RQ1)

What are interface characteristics promoting dexterous operation? (RQ2)

What are the interface configurations that offer better performance accuracy for touchscreen eyes-free interaction? (RQ3)

How do we support the practitioner in designing eye-free interfaces to attain high accuracy and efficiency? (RQ4)

The influencing factors in touchscreen eyes-free interaction are focused on spatial memory and proprioception. The first research question has now been answered in this chapter. The factors that influence spatial memory and proprioception were shown in Figure 2.7 and Figure 2.9.

2.9 Summary

The chapter presents the review of relevant literature for acquiring more specific research questions. Four research questions were identified, leading to the research design methodology. This literature review chapter also indicates cognitive psychology and physiology so as to uncover the underlying mechanism of eyes-free interaction focusing on touch-based interaction. Interacting with the eyes-free interface is associated with human cognition related to spatial memory and proprioception. The spatial memory and the proprioception are also explored thoroughly for greater knowledge and understanding. The relevant issues cover human cognitive ability, biomechanics of finger movement, human senses for target selection tasks, mobile interaction, and user interface design. Finally, the detailed discussion on key findings and the knowledge gap helps improve the design for mobile touchscreen interfaces. The next chapter will determine the research approach related to research philosophy and design research methodology.

Chapter 3 Research Approach

This chapter provides the general view of research methodology, consisting of philosophical assumptions about this study, a research design, a research method, and research ethics. The research will be beneficial and valid if it can develop a theory that brings about practical outcomes (Easterby-Smith et al., 2012). It should be systematised meticulously and equally attended to every phase. After identifying a broad area for researching and selecting the topic, the researcher should clearly identify the core function of the research and formulate its objectives. Then processes involve deciding an approach, formulating a plan, collecting data, analysing information, and presenting findings. To begin with, the research philosophy is described so as to be aware of the approaches of conducting research in this thesis. The overall picture of the research could help the researchers be able to recognise their position and stage in the study. Easterby-Smith et al. (2012) claimed that awareness of philosophical assumptions would increase research quality and stimulate researcher creativity. After the description of the research philosophy, the design research methodology, which is planned for finding new knowledge, will be presented. Next, the research method will explain the techniques in the collection and usage of empirical data on human-focused research in engineering design. At the end of the chapter, there will be the clarification of the ethical issues in conducting research.

3.1 Research Philosophy

Research philosophy informs the way that knowledge has been developed by researchers. Ontological philosophy concerns the researcher's own beliefs and assumptions about the nature of the world and reality to seek what exists to know (Saunders et al., 2015). Epistemological philosophy concerns the nature of knowledge and how knowledge is acquired, relating to the appropriate ways of inquiring into a certain concept or idea. The research has a purpose in expanding knowledge, developing universal principles, and producing significant findings that add value to society (Gray, 2014). The objective ontology could guide the way to reveal the reality of a certain thing.

Human-mobile interaction (HMI) research involves the communication between a person and a device. Thus, there is no doubt that both sensory experiences and participants' views could influence the response outcomes. To answer the big question about the reality of factors contributing to the eyes-free interaction and develop the interface design knowledge, the researcher would seek what exists to know and be aware of how to gain acceptable knowledge.

Thus, the literature review is to be conducted in the first place so as to get an overview of design properties and to find the existence of knowledge related to the nature of the design and the nature of humans. Then, the exploratory studies will be undertaken for a better understanding of the nature of interface and interaction. This will be the starting point to gain insights for developing ideas and the connection between various designs. For the specific objective of studies, an experimental approach is taken to the research since certain qualities of the interfaces would be tested and observed in a specific context offering high scientific control. In addition, the informal interviewing session with the participants is adopted together with the experiments, on condition that the results, derived from the participants' viewpoints and motivations, should be properly interpreted, because these factors may affect interaction and cause the obscurity of the truth. The results will be analysed and synthesised for the contribution to new knowledge. Insights into the influencing factors and their implications or relationships between independent and dependent variables could be obtained by experimentation and hypothesis testing.

This research has an objectivist ontology and involves a subjectivist epistemology. Four philosophies would be referred to in human-centred design research. Positivism relates to scientific observation based on empirical inquiry (Gray, 2014). The experiment typically starts with hypotheses and deductions. Easterby-Smith et al. (2012) suggested that the units of analysis should be reduced to the simplest terms. The observer must be independent of the subject. Therefore, the causal explanation and fundamental principle could be identified and generalised. On the other hand, constructionism typically adopts an inductive approach that aims to increase general understanding of the situation, the main driver of science. Thus, the researcher should incorporate stakeholder perspectives as a tool for interpreting the results. Triangulation, which is the use of a variety of methods, and a comparison are applied to analysis and interpretation. These are helpful for gathering rich data in order to obtain ideas. In the final process, the outcome will be treated as the theory generation (Easterby-Smith et al., 2012). Critical realism has much in common with the constructionist position (Gray, 2014). Critical realists make assumptions based on observation and experience. Saunders et al. (2015) explained retroduction as the use of external considerations to understand underlying structures of reality that shape observable events. The researcher perceived that empirical data is necessary to be observed and reasoning backward to gain knowledge from the stratified reality as shown in Figure 3.1. Finally, pragmatism is aimed to deliver practical solutions for future practice in specific contexts (Saunders et al., 2015).

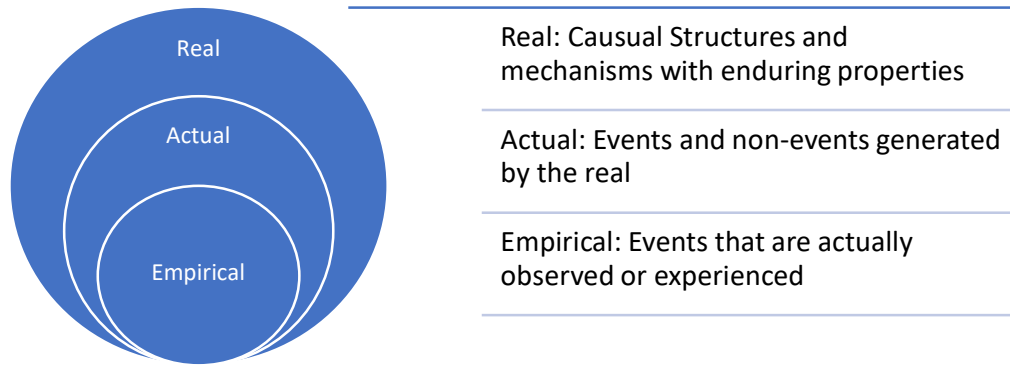

Figure 3.1 Stratified ontology of Critical Realism (Adapted from Saunders et al., 2015)

Saunders et al. (2015) compared many research philosophical positions and proposed HARP, a reflexive tool to heighten awareness of research philosophy. It is presented in a table, consisting of 30 statements asking about the researcher's belief and agreement on six aspects: ontology, epistemology, roles of values, research purpose, the meaningfulness of data, and nature of structure and individuality. Thanks to analysing these aspects, it was found that this research has a close position between positivism and critical realism, and some stances in pragmatism. The probable reason is that the research aims to find the fundamental mechanism of eyes-free interaction exploiting spatial memory and proprioception, and to deliver a design framework that supports effective eyes-free interface configurations. Furthermore, design guidelines for the eyes-free interface on the touchscreen device are proposed for practitioners to enable successful actions.

The works of literature provide viable information for further research and investigation. Consequently, the abductive approach or retroduction is chosen for theorising and developing knowledge in this research by the analysis of pre-existing findings and emerging information in the present and moving backward in time so as to identify the underlying mechanisms and structures that might have produced new knowledge. The logic of 'maybe' for abduction reasoning is applied to explain the obscure facts (Saunders et al., 2015). Thus, the rule that has been done before from the literature can be expanded or modified to the new case of eyes-free interface design.

The pattern of the findings from the controlled experiments is analysed for generalising statements and conclusions. The final stages are to validate the new design framework proposed in the practical cases and to investigate experts' opinions so as to confirm the new proposed practices.

3.2 Research design

In the previous section, the theoretical perspective in ontology and epistemology have been identified and approaches to theory development have been made. This section presents the research design and methodological choices. This research uses mixed-methods designs which are rigorous methods in collecting and analysing quantitative and qualitative data in response to research questions. Creswell (2015) compared the advantages and limitations of both quantitative and qualitative research and suggested the integration of these methods. Qualitative research captures the voice of participants and allows participants' experiences to be understood in context, and quantitative research analyses data efficiently and investigates relationships within data. This can be indicated that the qualitative one is highly subjective and has limited generalisability while the quantitative one is dry (impersonal) and provides a limited understanding of the context of participants.

The user-centred design needs expertise from various areas such as neuroscience and biomechanics linked with psychology, mostly from affective and cognitive sciences (Cash et al., 2016). What humans really think of a product is not easy to be captured and there is no standard technique suggested. Therefore, an experimental approach is often employed along with a short interview for the purpose of more effectively interpreting the causal relationship on experimental results. The specific methods are needed for each research question.

Experiments need both a systematic setup that involves repeatable procedures and testing methods as well as rigorous logical analysis and empirical reflection. Experimental methods aim to maximise internal validity that the result could provide the clearest relationships between cause and effect. The control in experiments is often at the expense of external validity or the extent to which the findings can be extrapolated beyond the focal research setting and sample (Johnson and Duberley, 2000; Cash et al, 2016). Controlled experiments with participants are frequently applied to test and examine design propositions or certain qualities of design.

Questionnaires are an effective method for collecting information from a respondent. A number of questions or statements are addressed about focal variables, requiring participants to indicate the level of a variable in a particular context under standardised measurement scales. However, their weak point is prone to prejudice because the aim is quite revealed or explicit. In addition, most of the participants are unable to imagine the effect of a new product on their behaviours. They mostly rate the new one based on familiarity with a known product.

The strength of the interview is providing the ability to understand an individual's context and motivations, and probing the responses and examination of complexity (Morris, 2015). However, this would spend a large amount of time and effort to arrange and transcribe interviews. The mixed-methods approach is often used in social, behavioural, and health science research where the investigator gathers both quantitative (closed-end) and qualitative (open-ended) data to combine the strengths of both sets of data so as to understand research problems and interpret the results (Creswell, 2015). Concisely stated, the statistical trends, and stories and personal experiences are integrated to draw interpretations by the researcher.

Reliability would be another aspect of evaluating research. It refers to the consistency of results obtained in research (Johnson and Duberley, 2000). In other words, the experiments and results should be replicable and consistent. The research process should be transparent through a structured methodology (Saunders et al., 2015; Silverman, 2021). To gain reliable data, this research sets the experiment details and data analysis methods thoroughly, including reviewing and refining the procedure under a pilot test before the collection of the actual data.

The cross-sectional studies are adopted to look at a phenomenon at a particular period of time. In other words, predictors and outcomes are measured at the same time (Cash et al., 2016). The exploratory study investigates the phenomena of human interaction to gain an understanding of the characteristics of the interface. In the descriptive studies, hypotheses are predicted and tested to examine the relationships between interface configurations and performance accuracy. The interface configuration causes performance accuracy indirectly, by first causing spatial memory, and then proprioception. In other words, spatial memory and proprioception are considered as the mediator variable, bringing about the main effect on performance accuracy. All the participants are allocated to each of the experimental conditions. The researcher uses repeated measures or within-participants design for all experiments. That is all participants are exposed to every condition or no personal differences between participants are in different conditions (Cash et al., 2016). Descriptive statistics such as mean and standard deviation or range are used to examine the central tendency and variability of the measured variables. Descriptive statistics are useful in case of a small number of participants. Inferential statistics are also adopted under hypothesis testing to generalise results beyond the specific ideas.

Design experience is a dynamic, complex, and multi-sensory phenomenon, so it must be investigated by multi-stages, multi-methods, and multi-modal means (Cash et al., 2016). To evaluate and understand cognitive and emotional mechanisms underlying human-mobile

interaction and design cognition, this research applies questionnaires, interviews, and experimental approaches. There are three knowledge types that could be synthesised in design research: know-what, know-why, and know-how (Cash et al., 2016). Know-what is descriptive knowledge, including general contextual understanding of phenomena, constructs, and variables. Know-why is explicit knowledge that clarifies the relationship between constructs and variables. Know-how is procedural knowledge or formal processes to accomplish a given task. It is important to formulate a set of clear research questions implying the ways the subject will be investigated and researched. To achieve the research aim and objectives in designing effective interface configurations in touchscreen eyes-free interaction, a research methodology in an integrated and systematic way is essential.

The research relates to the processes of investigation that reveal the relationship between independent and dependent variables. These variables were primarily found from undertaking a literature review (Gray, 2014). Though the literature is mostly in different contexts due to the uniqueness of the research problem, doing a literature review discloses many relevant studies on variables. The literature review is, therefore, conducted early to get an overview of the interface design and to find the existence of knowledge concerning the nature of human cognition. The identification of the knowledge gap was also mentioned in the literature review. This review can suggest the influencing factors in touchscreen eyes-free interaction that address the first research question (RQ1).

After the literature review on cognitive engineering, the basis of human performance has been conducted, the preliminary study is undertaken to explore the role of risk and pressure in user operation under the product interfaces, and to investigate the phenomenon of human interaction for improved comprehension of the characteristics of the spatial interface. This discovery can answer the second research question: What are interface characteristics promoting dexterous operation? (RQ2). Ultimately, the design criteria referred to performance accuracy and dexterous operation were identified. This provides the focus for the next phase.

The main phase involves the exploration and development of interface configuration prototypes and the descriptive study of the interface configuration prototypes to understand the various interface characteristics that influence the performance accuracy in touchscreen eyes-free interaction. To thoroughly examine the role of interface configurations on spatial memory and proprioception, two experiments are conducted, which provide the answer to the third research question: What are the interface configurations that offer better performance accuracy? (RQ3). After that, the development of a design framework and design guidelines

(Prescription) takes place. The logical reasoning for Prescription or methods of the interface design process is from experience and assumptions which are based on the outcome of the descriptive study. The final phase is the validation of the results of Prescription, so the second descriptive study is conducted for testing the design framework and design guidelines for applications. Blessing et al. (1998) suggested that two main issues need to be examined, which are to validate whether the method has the expected effect on the influencing factors and whether this indeed contributes to success. Therefore, the observation and analysis are also provided by the interview of experienced designers other than the comparative experiment. This validation can answer the fourth research question: How do we support the practitioner to design eye-free interfaces to attain high accuracy and efficiency? (RQ4).

3.3 Research techniques

The research techniques involve data collection and data analysis. At first, the researcher does an observation on the mobile user interface and the context of the use, aiming to understand the user experience on touchscreen and handheld devices so as to improve the touchscreen interface configuration for eyes-free interaction. The mind map is used for generating ideas gathered from observation and literature review, and the demand qualities is identified for designing interface configuration prototypes. The quality function deployment (QFD) is used in the requirement definition stage to set systematic thinking on design parameters. Concept sketches and touch screen tests from mobile applications are used in the conceptual stage. The computer-aided design (CAD) is used in the detailed design stage. To make the data reliable for data analysis and research validity, an experimental apparatus which can officially inform the response time and touch coordinates is constructed. The experiments are well-planned and well-designed then the pilot tests are carried out prior to the experiments.

To discover the reality of eyes-free interface design, the empirical data is collected from the experiments, the observations, the interviews, and the questionnaires. The experimental method aims to analyse human-interface operations in the controlled conditions with measurable criteria, numeric data output, and statistical data analysis. On the other hand, the qualitative data, including the participants' opinions and experiences, will be enquired about and observed by the researcher as well. What the participants and the researcher perceived will be reflected to give a better understanding other than the numerical findings. The use of various methods could intensify the reliability of data in research. The prescriptive method for developing design support tools involves framework analysis and process flowchart creation. Figure 3.2 shows the overall research design and techniques.

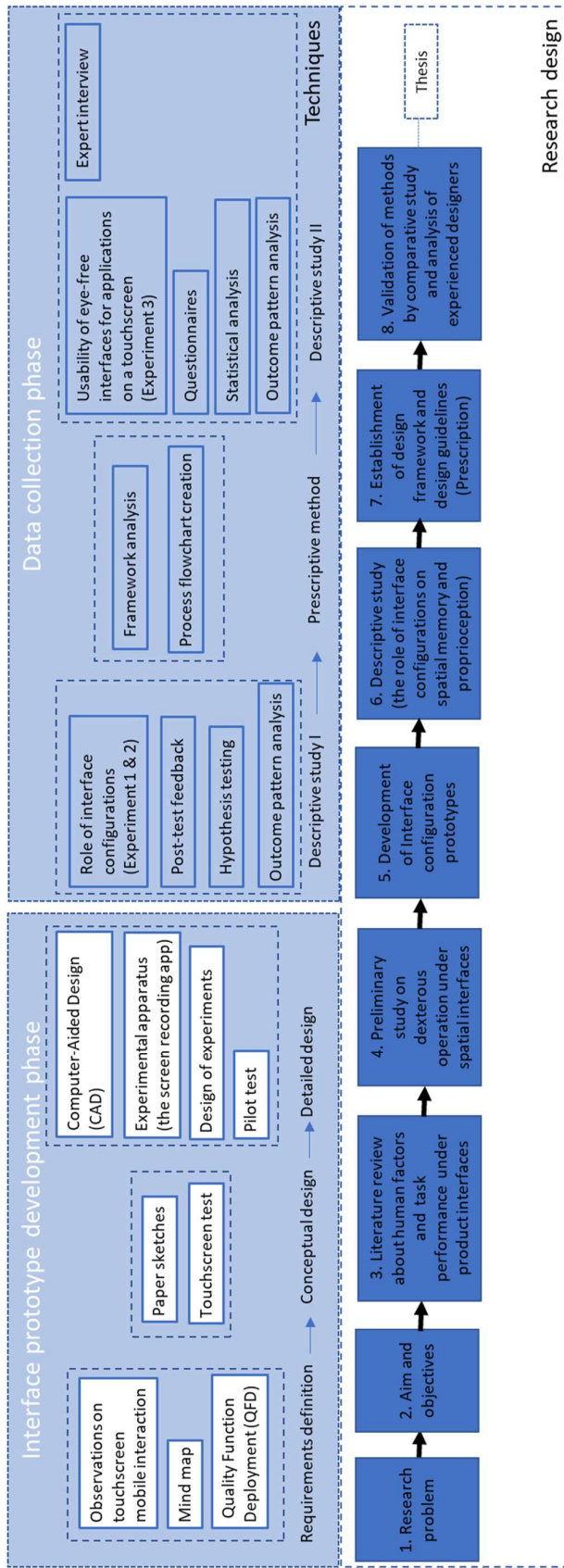

Figure 3.2 The overall research design and techniques

3.4 Research ethics

Human-focused research in engineering design involves human participants. The researcher needs to follow the ‘Code of Practice on Investigations of Humans Beings’. The purpose of ethical review is to ensure participants’ well-being and to make sure the study meets the general data protection regulation (GDPR). In experimental studies and interviews, the participants should be at a minimum risk. The participants’ personally identifiable data would be respected and confidential. Data collected in the study should remain secure and be presented in an anonymous manner. All of the participants have been provided the participant information sheet before their deciding to take part. This form introduces the study purposes, the researcher’s name and affiliation, the reason for the invitation, and the processes of data collection. Participation in this research is voluntary so the participants need to acknowledge the study information and sign the provided consent form. Table 3.1 shows the study, method, and participants involved in this research. Though the number of participants depend on many factors such as participants' characteristics, available time slot, and voluntary, the number of participants in the exploratory studies (Study 1-3) should exceed fifteen (Cohen et al., 2007). On the other hand, the usability studies (Study 4-5) require at least ten participants (Six and Macefield, 2016). In order to avoid the bias from a single interviewee, it is determined that the minimum 3-5 experienced designers need to be interviewed in the final phase.

Table 3.1 The number of participants in studies

| Study | Method | Participants |
|---|--|--------------|
| 1. The role of risk, pressure and stress in the user operation and product interface design | Experiment on two interfaces: a keyboard and jigsaw | 21 |
| 2. Interface Configuration for Eyes-free Interaction (Exp 1) | Multiple representation test on a touchscreen mobile | 22 |
| 3. Interface Configuration for Eyes-free Interaction (Exp 2) | Single representation test on a touchscreen mobile | 22 |
| 4. Comparison between the conventional and new formats of interface configurations | Questionnaire on interface configuration formats | 11 |
| 5. Usability testing for Eyes-free Interaction | Application interface test on a touchscreen mobile | 11 |

| Study | Method | Participants |
|--|------------------|--------------|
| 6. Interface Configuration for Dexterous and Eyes-free Interaction | Expert interview | 4 |
| Total participants | | 91 |

3.5 Summary

This chapter outlines the approach adopted in this research. It consists of the discussion on the research philosophy, the methodology for research management, and the professional conduct so as to enhance the quality of the conduct of the research. The justification of the philosophical stances, the research design, and the research techniques is provided. Finally, the research ethics involve standardly and appropriately treating the participants in each study throughout this research.

Chapter 4 Understanding human ability under spatial interfaces for dexterous operation

This chapter aims to address the second research question: what are the characteristics of the interface that promote dexterous operation? Anderson et al. (2019) found that the existing design of the control interfaces impacted operators in normal and high-stress situations differently. The product interface is the product's part which the users look at and interact with. It contributes to users' cognition, response, and task performance respectively. Many factors could cause the increment of mental workload, for instance a rush from time availability decreasing, and a higher level of task challenges. Thus, the experiment was conducted to gain insights into interface characteristics design for dexterous operation.

The chapter presents the preliminary study that enhances understanding of the human ability to differentiate spatial interfaces in time-stressing conditions. Previous researchers had separately explored this relevant topic on the typing task (Hughes and Babski-Reeves, 2005) and the jigsaw puzzle task (Richardson and Vecchi, 2002). To bridge the gap between insights on characteristics of the different spatial interfaces, the result of task performance, therefore, will be comparably explored on both interfaces in this study under the mentally overloaded and normal conditions. Figure 4.1 illustrates the linkage between spatial interfaces, cognitive abilities, and task performances under dexterous operation. The effective interface should contribute to robust performance, preventing user errors no matter what circumstances are and whether it is normal or time stressed.

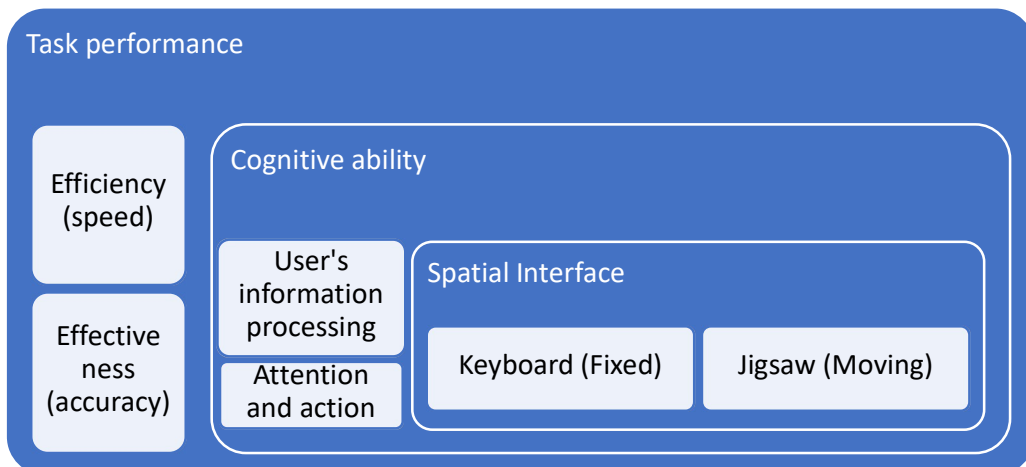

Figure 4.1 Dexterous operation study on the spatial interface

The interface appearance could be presented by using visual cues, system design, or product layout so as to give users communication with operating the task. Several design elements, including visual cues, control layout, and other communication formats have an influence on human perception (Rasmussen and Vicente, 1989). Visual cues help emphasise important information as well as reinforce personal learning (Sam et al., 2019). For example, they focus on visual directions or instructional cues, shape, colour, word, and picture. They draw attention and make it easier to memorise important information.

It is considered that the designs of product interfaces could affect human cognitive performance (Norman, 1984). In addition, the task situations would contribute to the user's perception and interaction (Illera et al., 2010). On account of the fact that human information processing processes contribute to decision and control operation, designers should consider these aspects to design a better version of interface.

This study is intended to observe the interface characteristics and human cognitive limitations that affect task performance in movement control. The performance evaluations provide insights into the design of the product interface.

4.1 Aim of preliminary study

The aim of this study is to explore the characteristics of the spatial interface that are robust in memory, causing quick response with a fine performance. Generally, the spatial interface will be divided into two types: fixed (stationary) and moving (movable; dynamic data representations) interfaces (Andreyev, 2012). For this reason, in this study, the keyboard is used as a fixed spatial interface while the jigsaw puzzle pieces are treated as moving spatial interfaces.

The insights from understanding the spatial interface characteristics could be applied to designing a better interface for dexterous operation. Dexterity is defined as the ability to think and effectively perform a difficult action in a quick and skillful manner with the hand. This study is, consequently, designed to answer the following questions:

How do the psychological disturbances affect user performance on the various types of interfaces?

What are interface characteristics promoting dexterous operation?

4.2 Task design and experiment procedure

The keyboard interface could be called the indirect input modality for interacting with the computer screen due to the different locations of input and output (Müller et al., 2019). Eye-hand coordination would be a correlation of information from visual and kinesthetic modalities (Wallace, 1972). For example, when individuals perform touch-typing, they perceive visual feedback and tactile information from display and keyboard interfaces. However, typing could be done without looking at the screen, resulting from spatial memory and proprioception of the key positions. On the contrary, the jigsaw puzzle task must be directly and visually manipulated. Thus, the exploration of these different interface characteristics used in daily life could bring about insights into designing the optimal eyes-free interface.

This study explores the effect of psychological disturbances on task performance when interacting with the fixed and moving interfaces, and investigates human interaction under dexterous operation for a better comprehension of the characteristics of interfaces that are resolute and that promote spatial memory and proprioception exploitation. Though this is an ‘eyes on’ test, its findings could provide basis and relevance in an eyes-free interaction. The exploration of different visual interfaces could enhance the understanding of human cognitive ability to recall spatial interfaces, and then contribute to proprioception. Providing effective visual representation enhances the development of mental models (spatial memory) so the appropriate configuration of spatial interface could reduce the cognitive and physical efforts for dexterous operation.

Different combinations of physicalizing strategies are available on the interface (Dragicevic et al., 2021). The keyboard interface will map or embed the usage data to the key button it touches, and the output will show on the screen (indirect approach). Touch typing or interaction on the keyboard with dexterity is caused by exploiting spatial memory and proprioception properly. While the jigsaw puzzles directly illustrate the use and outcome of visual pieces in themselves, doing a jigsaw with dexterity requires a spatial memory of an imagined picture. Indeed, it should be noted that the focus on spatial memory and proprioception in this thesis subsequently emerges from the results of this study.

Mental overload occurs when a task is more challenging than a person's ability (Csikszentmihalyi, 1997). The task difficulty and time pressure deteriorate the ability to recall cognitive tasks (Wu et al., 2016; Earles et al., 2004). Anxiety caused by difficult tasks or tasks with time pressure results in focusing cognitive resources on self-evaluative thoughts. Therefore, cognitive resources for the formation of a strong memory trace get worsen. There

is a risk of error when the short-term memory is overloaded (Norman, 1984). The experiment was also designed to examine human memory performance on challenging tasks under time pressure. The tasks were applied to two interfaces in the experiment for the non-Thai participants. Because most people are familiar with the general keyboard usage, the task was designed to increase a cognitive challenge by using the English keys to type the 20 words of Thai letters. The 3-designated words were constructed and shown in the left column of the document for Task 1 (Figure 4.2). Participants had to recall Thai words, then mapped the key buttons and pressed them in the correct sequence in the right column of the document.

In addition, a set of 20 jigsaw puzzle pieces had been prepared for the jigsaw test in Task 2. The part of the puzzle picture (Figure 4.3) was selected to test in the experiment. It contains 5 bottom-flat pieces and 15 interior pieces. The vertical and horizontal jigsaw shapes were interleaving combined to form a picture in the correct position and direction.

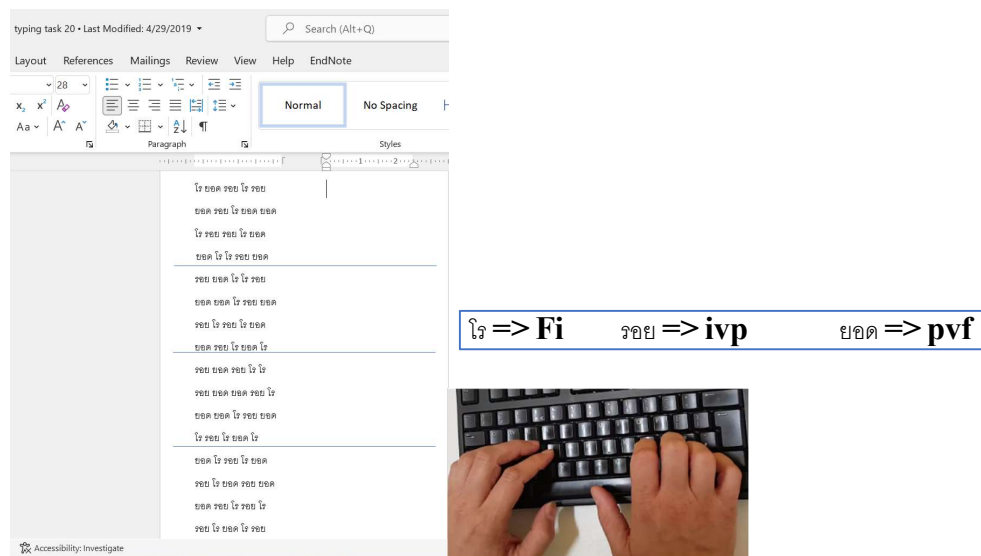

Figure 4.2 The set-up in the experiment on Task 1: typing the 20 words of Thai letters



Figure 4.3 The set-up in the experiment on Task 2: assembling the 20 pieces of a jigsaw puzzle

The repeated measures design was adopted in this study; thus, all participants had to respond and interact with both of the interfaces under two-handed coordination. The experiment was set up in an unobtrusive study room with an appropriate lighting environment. The stopwatch and countdown timer were used in the normal and time-pressure conditions respectively. Participants followed the provided instruction and practised with time before the test. In the normal condition, the response time to complete a task was evaluated along with the task accuracy. On the other hand, the completeness and accuracy of the task were analysed in the time-pressure condition.

The word and the jigsaw piece were presented in a random position on each trial. Both tasks required eye-hand coordination along with cognitive ability. Participants had practised one trial before starting the test in the normal condition. There were 4 trials per condition. Trial 1-4 were the normal condition (a) and Trial 5-8 were the time-pressure session (b). All participants were exposed to every condition. Trial 1 to trial 4 were for measuring baselined efficiency and training. The task instructions were still provided to participants at this stage of the experiment but had been taken out during the time constraint condition. The time in Trial 5-8 was set to reduce further from the previous trial as shown in Table 4.1. Participants were required to stop performing the task when the time was over. The response time in the time pressure condition would be the actual value if participants had finished the task before the time limit.

Table 4.1 Time set-up and variables for each trial

| Trial | (a) Normal condition (seconds) | | | | (b) Time-pressure condition (seconds) | | | |
|--------|--------------------------------|----------------|----------------|----------------|---------------------------------------|----------------------|----------------------|----------------------|
| | 1 | 2 | 3 | 4 | 5 | 6 | 7 | 8 |
| Task 1 | t ₁ | t ₂ | t ₃ | t ₄ | 35 or t ₅ | 30 or t ₆ | 20 or t ₇ | 15 or t ₈ |
| Task 2 | j ₁ | j ₂ | j ₃ | j ₄ | 80 or t ₅ | 70 or j ₆ | 60 or j ₇ | 50 or j ₈ |

Note: t and j mean the actual response time in the typing and jigsaw tasks, respectively

A brief and informal talk was conducted before and after the experiment about their backgrounds and opinions on the task they had just performed. Since the participants are non-native Thai and not familiar with the Thai language, they perceived each word as a sign instead. They had to learn the signs and practise according to the instructions, then retrieve the memorised information and perform the corresponding sequence. In this case, spatial working memory involves both recalling the target locations and a sequence of movements to the target (Logie, 2011).

In these cognition and speed challenge tasks, the participants had the missions for performing the task as follows:

Participants' mission: 1a (Normal condition): Do it quickly and accurately as you can.

Participants' mission: 1b (Time-pressure condition): Do it completely and accurately as you can within the assigned time.

After the missions, the response time recorded was analysed as the speed performance. In each trial, the amount of words typed was compared with the amount of correctly-typed words while the total number of the jigsaw pieces done was evaluated with the total number of the correctly-done jigsaw pieces. The comparison of the net speed and the error rate was made between the normal and time-pressure conditions. The mistake patterns were also taken into account. In order to monitor the participant's interaction during each task, video recording was used. Figure 4.4 shows the experimental setup in this study.



Figure 4.4 Experimental set-up

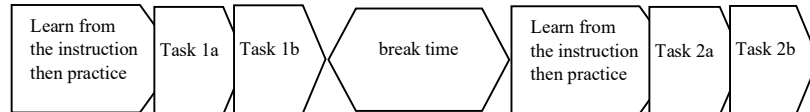

Figure 4.5 Protocol of the experiment

Figure 4.5 shows the experimental protocol. 21 persons (12 males, 9 females) voluntarily participated in this study and were applied to this protocol. Their ages were between 23 and 36 with an engineering and management background, and having an ability to type regularly. Most participants (13 from 21) had the ability to touch typing. Everyone got used to right-handed activities. They have experience in doing a jigsaw. However, after the experiment was conducted for the first ten participants, the colour of jigsaw pieces had faded unexpectedly. Thus, the researcher has to use another part of the puzzle picture with a similar complexity for the rest of the experiment from participant number 11 to 21 in task 2. The left white box in Figure 4.3 is used for Set 1 while the right box is for Set 2. The overall experiment consumed around one hour.

4.3 Result and analysis

This section presents the result of the experiment. It is categorised into the fixed and moving interface outcomes. The results consist of the average response time, error rate, error pattern as well as participants' behaviours and strategies to accomplish tasks.

4.3.1 Fixed interface (Keyboard)

Figure 4.6 provides an example of the result and button locations of typing errors in Task 1. As seen on the figure, the number of words done on the right column did not reach the target number (20 words) assigned on the left column under the time pressure condition. The average of the net typing speed on each trial was presented in Table 4.2. On Trial 1-4, the speed was gradually developed as the practice time increased. However, the growth rate was slightly

investigation, the probable reason might be that the interaction on the ‘ivp’ word quite swings from left-right-left.

Table 4.4 The cause of typing error in percentage

| | normal | time-pressure |
|---------------------------------------|--------|---------------|
| pressing the wrong button | 1.83 | 2.43 |
| typing wrong word | 1.43 | 1.77 |
| pressing key incorrect order | 0.40 | 1.92 |
| missing words | 1.11 | 1.03 |
| forgetting to unlock the shift button | 0.63 | 1.40 |
| missing keys | 0.79 | 0.96 |
| typing excess letter | 0.71 | 0.74 |
| % Error | 6.90 | 10.25 |

Table 4.5 The proportion of word error

| | normal | pressure |
|-----|--------|----------|
| Fi | 36.6% | 28.9% |
| pvf | 28.0% | 23.7% |
| ivp | 35.4% | 47.4% |

Behaviours and strategies from typing tasks were observed that the participants often used their index finger and middle finger on both hands for typing the letters and used the thumb for tapping the spacebar under symmetric bimanual interaction. For the word ‘Fi’ which requires pressing the two keys simultaneously at first for the capital letter, the participants had tried to optimise the finger strategy suited with the ability to minimise the time and distance to move. For example, some participants used the right little finger to press the Shift button on the right and used the left index finger to press the ‘f’ letter at the same time, whereas some used the left little finger to press the Shift button together with the left index finger to press the ‘f’ letter key, then pressed the ‘i’ with the right index finger. In other words, they assigned their fingers to specific key positions to perform tasks with dexterity. Evidently, there is a slight change of strategies from those participants when performing in the time constraint situation.

4.3.2 Moving interface (Jigsaw)

The average of the net speed on each trial for the jigsaw task is presented in Table 4.6. Surprisingly, the speed in this task was quite slow as opposed to the typing task in spite of the fact that the speed was gradually developed from the previous trial in accordance with the practice time. The speed improvement in the time-limited condition was poorer than the one in the normal condition. This result conforms with Richardson and Vecch’s findings (2002)

showing that the time limitation impacts cognitive performance. The result has a similar trend for both jigsaw sets. Table 4.7 shows the average rate of error in doing the jigsaw. There was no error recorded during the normal condition as any possible errors had been corrected before the task finished. The errors that occurred could be detected in time and solved for the direct manipulation task on the jigsaw task as opposed to the indirect interaction on the typing task. Thus, the average error rate is just 0.45 pieces per person. Similar to the fixed interface of the typing task, the time pressure affects the performance accuracy of the jigsaw task.

Table 4.6 The average of the net speed on each trial in Task 2

| Trial | Target speed (pieces per minute) | | | | | | | |
|---------|----------------------------------|------|-------|-------|-------|-------|-------|-------|
| | 1 | 2 | 3 | 4 | 5 | 6 | 7 | 8 |
| Set 1 | 4.50 | 5.23 | 5.74 | 8.09 | 8.83 | 9.77 | 10.58 | 10.83 |
| Set 2 | 9.02 | 9.00 | 10.03 | 13.14 | 13.64 | 13.94 | 15.11 | 16.23 |
| average | 6.76 | 7.11 | 7.89 | 10.61 | 11.28 | 11.85 | 12.89 | 13.58 |

Table 4.7 The average error rate (pieces/person) on each trial in Task 2

| Trial | 1 | 2 | 3 | 4 | 5 | 6 | 7 | 8 |
|---------|---|---|---|---|------|------|------|------|
| Set 1 | Errors had been fixed before the task finished. | | | | 0.65 | 0.67 | 0.72 | 0.43 |
| Set 2 | | | | | 0.32 | 0.00 | 0.24 | 0.52 |
| average | | | | | 0.48 | 0.34 | 0.48 | 0.48 |

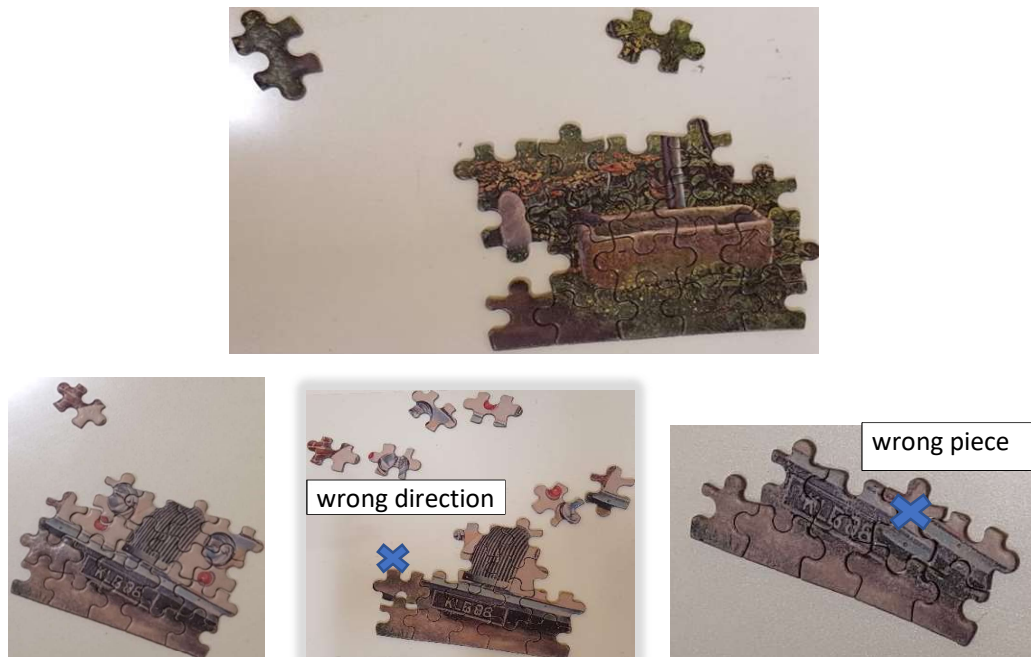

Figure 4.7 Examples of the results and error patterns in Task 2

Examples of the results and error patterns in Task 2 are shown in Figure 4.7. The causes of the error on the jigsaw task are categorised and presented in Table 4.8. Most errors were caused by putting the incorrect pieces of the jigsaw. When the participants were overloaded with information and time pressure, they usually could not notice the little difference between pieces that brought about selecting the wrong ones. Most of the participants were able to remember around at least 8 pieces from the whole picture. They often assembled these pieces first and then seemed to be slower in connecting the additional pieces.

Table 4.8 The percentage of errors on jigsaw task

| Error patterns | % |
|-----------------|------|
| wrong piece | 61.5 |
| wrong direction | 38.5 |

Behaviours and strategies from doing a jigsaw task were observed that the participants often form a picture from the base row by searching for the bottom-edge pieces first, figuring it out about the area that they will be, and then putting them into place. After that, they sorted the inside pieces that looked similar, clustered them, or sought the target piece to build up part from the base row. Ehrlich (1996) claimed that good visual skills result in a better mental model for information navigation. In the time-pressure condition, it was observed that the participants took a lot of time in rearranging the puzzle pieces or attempted to compress them in the incorrect area. This implies that time pressure could deteriorate thoughts. Indeed, the participants failed to find visual perception and spatial awareness properly, resulting in not being able to put their jigsaw pieces in the correct positions.

4.4 Discussion

The more the information had to be considered, the more time and effort a person had to process. That the jigsaw pieces are dynamic or spatially changed, increases response time to orientate the information. The mission strategy in the moving interface was different from dealing with a fixed interface. Due to participants placing their fingers around the fixation pointed on the keyboard, the task duration was relatively short on the fixed interface. With the fixed interface, they could use their proprioceptive sense other than the cognitive ability to facilitate the task (Probst, 2016).

To compare the dexterous operation under all situations, the task speed improvement was analysed for each interface in Figure 4.8. The speed increment was calculated by subtracting the current speed value from the previous speed. Therefore, the value should be positive for speed improvement. The experiment shows that the transition turn towards the time-pressure condition on the keyboard task brings about the slightly decreasing speed, thus the increment

value was negative solely in that period (between trial 4 and trial 5). The average speed increment in the normal condition was 3.15 on the keyboard interface but 1.28 on the jigsaw interface. The increment rate was unexpectedly developed to 4.04 in the stressful condition on the keyboard task while only 0.76 on the jigsaw task. The net speed and the speed increment are remarkable on the keyboard interface, at least two times from those on the jigsaw interface (Table 4.2, 4.6, and Figure 4.8). The probable reason might be the characteristic of the interface. The fixed interface engaged the amount of working memory less than the moving interface. Doing a jigsaw requires a higher degree of mental energy which directly affects brain fatigue and impacts the task performance. Zeidner and Matthew (2011) concluded that on the easy task, the capability may be facilitated by a feeling of worry. This indicated that, under the psychological disturbance in the practical situations, the fixed interface might be more robust than the moving interface.

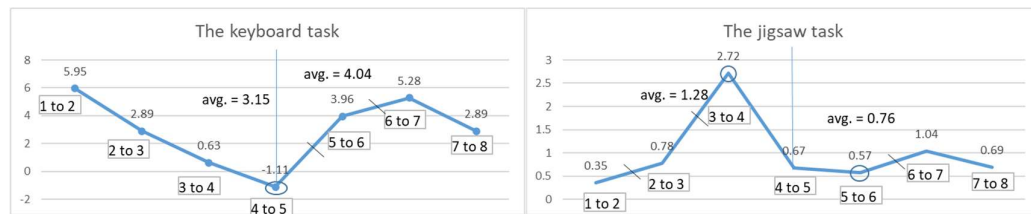

Note: The vertical lines show the transition turn from the normal to the time-pressure condition

Figure 4.8 The speed increment comparison on Task 1 and Task 2 between the fixed and moving interface

4.5 Insights into the spatial interface and interaction design

Time pressure influences the cognition, recognition, judgement, and fine motor control of operators. Illera et al. (2010) suggested that the design solution should support the performance and cognitive ability composition. The interface types and task complexity differently affect mental pressure, physical processes, and performance accuracy. The insights into the spatial interface design which facilitate the users' cognition and improve task performance for the dexterous operation were proposed as follows:

The fixed interface layout should be appropriate and the size and distance between each key should also be adequate. The sequence or transition between buttons should be smooth in the connectedness process. In other words, the designs should be consistent and in the same direction. To accomplish the task with dexterity, the control interface should be designed for performing in a balanced manner and mobility. To prevent errors, feedback should be immediately provided to the users such as graphic information highlighted or audio. By assigning a finger on a specific button in the working area, participants will operate at a higher rate with a spatial map they generated. The interface should be easily recognised and should

not too much burden the user's memory, effectively supporting non-visual touchscreen interaction.

To improve the design of the moving interface, it is necessary to decrease the diversity of categories and group them to facilitate the orientation or navigation to users. The symmetrical pattern would be a clue to arrange an orientation. The basement will be easier to recognise and align. It could be beneficial in using distinctive features like colours or other non-spatial attribute information to provide cognitive cues. If the interface offers an explicit relationship between the sections and the spatial reference, users will develop a mental model effectively. Finally, a confirmation or suggestion should be given to enhance the use's confidence.

The findings also suggested that participants used or adapted various strategies to heighten their abilities. They could learn and interact better with the fixed interface than the moving interface under difficult conditions. The empirical study on interface and interaction provided much more understanding that interface and interaction design could impact the speed and accuracy of the task. If the interface was designed effectively, it should help reduce errors, enhance the user's skills and the flow experience (Csikszentmihalyi, 1997) for dexterous operations. The proprioceptive awareness and muscle memory could be applied on the fixed interface, resulting in performing familiar tasks with dexterity. The connection between mental and physical abilities to activate the movement of muscles voluntarily according to the sensory information within the body is also known as the conscious proprioception. This can be assumed that it is important and beneficial to design the appropriate interface for exploiting human abilities and to mitigate the users' mistakes.

This experimental study explores cognitive behaviours and accuracy of performance for the dexterous operations on the fixed and moving interface between normal and stressful situations. Dexterous operation conveys the balance of speed with the performance accuracy that is compatible with psychological and spatial constraints. The findings indicated that the time stress brings about a deteriorating performance in tasks. Although the speed of performance had been increased under this condition, the effectiveness and accuracy turned out to be degraded. The researcher suggests that interaction with a spatial layout on a fixed interface requires lower mental and physical demands as opposed to the moving interface under the time pressure condition. Table 4.9. provides the considerations for designing an effective spatial interface. The design goal for the fixed interface focuses on the layout design as well as particular configuration while the moving interface relies on the effective visual design. The fixed interface is a robust interface that could effectively exploit innate human abilities in both spatial memory and proprioception for dexterous operations. The interface that is stable supports indirect touch and eyes-free interaction. In summary, the eyes-free

interaction would be the interaction effect of spatial memory and proprioception (Figure 4.9). Under the eyes-free interaction, spatial memory related to the recalling of the interface configuration serves as an important information source for the planning process for movement control of proprioception. As a result, a person could accurately touch the target without looking at the input interface.

Table 4.9 Considerations on designing spatial interfaces for dexterous operations

| Spatial interfaces | Fixed interface | Moving interface |
|-----------------------|---|--|
| Focus on | Configurations (location, size, and distance between targets) | Visual clues (shape/colour/image) |
| Interaction technique | anchoring fingers and hands then navigating to targets | visual searching/discrimination on the ground of visual perception |
| Human ability | Spatial memory and proprioception | Spatial memory |
| Application | Indirect and eyes-free interaction | Visual interaction |

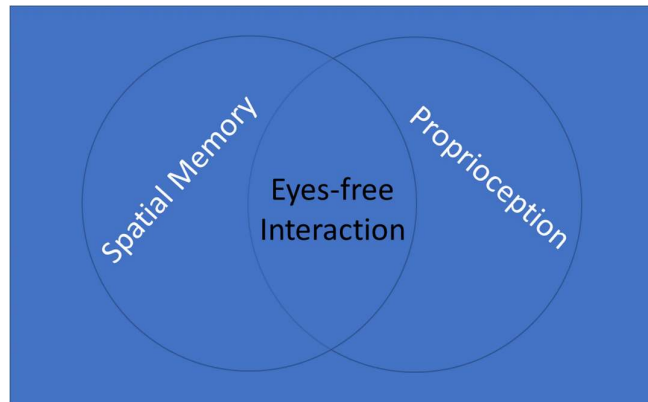

Figure 4.9 Eyes-free interaction within the context of spatial memory and proprioception

4.6 Summary

This chapter presents the preliminary study to understand the interface characteristics for spatial design. The experiment was conducted to understand the effect of time pressure (mental workload) on task performance on different spatial interfaces and answer RQ2. The existing interfaces were tested to provide design suggestions. The chapter illustrates design and approach, experimental procedure, results and analysis. The outcomes were discussed in

human cognitive abilities (performance analysis, error pattern, behaviour and strategy) on a spatial interface. The findings show that a good layout design of a fixed interface facilitates dexterous operations. Though this is an 'eyes on' test, the insights into interface characteristics of a set of jigsaw puzzles and a keyboard that exploit spatial memory and proprioception could finally provide basis and relevance in an eyes-free case. The exploration of different visual interfaces could enhance the understanding of human cognitive ability to recall spatial layout, and then contribute to proprioception. This leads to the design research on spatial interfaces for eyes-free interaction. The next chapter will present the development process of eyes-free interface prototypes for the data collection phase.

Chapter 5 Spatial interface prototype development for eyes-free touchscreen interaction

In this chapter, the researcher aims to configure interfaces concerning the spatial layout and having an influence on spatial memory and proprioceptive sense explored in Chapter 2 by developing interface prototype designs that allow the researcher to explore the design framework and configuration characteristics that can support the non-visual touchscreen interaction. To begin with, this chapter provides the description of interface design for eyes-free interaction on the mobile touchscreen. In designing eyes-free interfaces effectively, the tools and methods are used for defining design requirements. Then, the ideation phase is described, involving the conceptual and detailed design of the eyes-free interface configuration. In addition, the creation of experimental apparatus is proposed for the data collection phase. At the end of the chapter, it specifies designing for prototypes of thirteen structured layouts and two unstructured layouts.

5.1 Eyes-free interaction and spatial interface design on touchscreen mobile

In this section, the eyes-free interaction schema on the mobile touchscreen is proposed as shown in Figure 5.1. Users hold the device in one hand and operate the unseen flat mobile screen with a thumb. The mobile is supported with a palm and other fingers under different thumb postures. In this research, the user interface does not directly display on the device. Users develop spatial memory from the visual interface which has been viewed and memorised before and then interact on a touchscreen without visual attention. To exemplify, spatial memory of interface layout might be encoded from the direct experience on the same device or on other remote display devices such as a desktop screen, a head-mounted display, or AR smart glasses. Information retrieved from spatial memory could inform about the target position and contribute to motor planning and postural set. The accurate movement requires information about the limb position in relation to the objects and the body's position under proprioceptive processes. Thumb anchoring on the mobile screen frame relates to the hand grip position. The movements at a joint of an opposable thumb include flexion, extension, abduction, and adduction. These enable a person to select any target deliberately under eyes-free interaction because of taking advantage of spatial information of imaginary interface and proprioception.

The indirect manipulation of non-visual tasks results from the cognitive processes under the coordination of spatial memory and proprioceptive sense or the sensorimotor system (mind

and body). The effective stimuli, for example, edges, corners, skin motion, and stretch from tactile interaction provide information, including the surface form and texture perception of the object, posture and grip control, perception of distant events, tangential force, and motion direction. These human sensory functions come together with proprioception from the muscle spindle to enable the ability to discriminate distance between two points in a certain range.

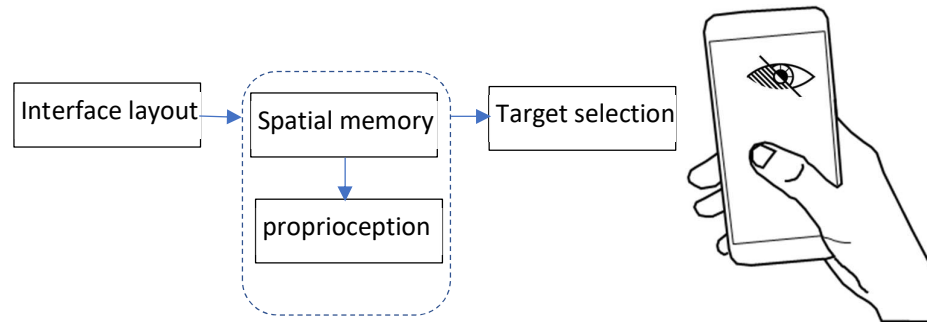

Figure 5.1 Eye-free interaction schema on a touchscreen mobile

The human sense of touch integrated with an internal sense from proprioception brings about inputting tasks and provides internal feedback in relative proximity distance. Users adopt the mobile as a peripheral device to select a menu on a flat screen without a vision clue by retrieving or recalling information from their spatial memory of interface configuration. Users need to imagine a relative spatial layout and tap on a match position of the target with tactile sense in the unseen flat mobile screen. The learning and practice processes result in spatial memory as well as muscle memory. These experiences form the imagery ability when users interact with the eyes-free interface while the working memory is responsible for the action preparation, sensory perception, control of action, and decision-making processes.

Interactions under this study rely on both spatial memory (SM) and proprioception (PP) as there is no augmented feedback provided. Therefore, the interface layouts must have already been memorised and encoded in the human cognitive map before each layout testing. Under the spatial layout mapping process, users retrieve this spatial interface in order to respond to the task accurately on an unseen touchscreen.

This research aims to improve understanding of proprioception and spatial memory in order to deliver a framework and guidelines that help support effective eyes-free interface configurations on touchscreen surfaces. Depending on this aim, the fundamentals of spatial memory and proprioception, hand movement and control, mobile interaction, and various forms of the interface as well as interaction with visual and eyes-free modes were explored in Chapter 2 for revealing key design variables. Many tools were used in the design processes of

the interface configuration on a touch screen mobile. To exemplify, the mind map was used in the inspiration phase so as to generate ideas and factors that contributed to eyes-free interaction (see Appendix 1). A range of ideas related to the main issue was developed through word association contributing to holistic thinking for the improvement of interface design. These factors are relevant to the human and physical realm, focusing on spatial memory, proprioception, and design characteristics. The interface configuration design attempts to fully harness innate human abilities and product affordance for effective eyes-free interaction. The next section will provide the design processes of eyes-free interface prototypes.

5.2 Requirements definition

Designing a spatial interface for eyes-free interaction involves the configuration of targets relative to the mobile screen frame. The indirect visual representation of this interface impacts spatial memory and proprioception ability. The characteristics of target configuration impacting the eyes-free interaction derived from the literature review are summarised in Figure 5.2. The eyes-free interface design characteristics concern the number of targets or buttons, alignment, button size and shape, symmetry, button proximity (spacing size and pattern), structure, and distance (position) from the landmark. In addition to spatial relation, the interface configurations involve semantic relation on path characteristics or sequences of the menu.

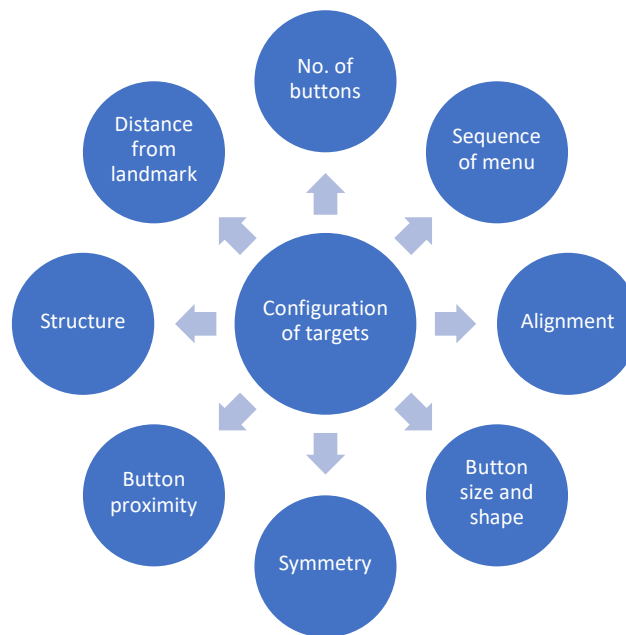

Figure 5.2 Characteristics of target configuration that impact both spatial memory and proprioception, derived from the literature review

To discover insights into the design problem, the design requirements for the interface were gathered from research motivation and literature on user interface design guidelines. As a result, the primary data for the design features was acquired. Many user-interface and user-experience design guidelines propose common sets of design rules, such as prevention of errors, consistency, ease of learning, minimising memory load, easiness to remember, easiness of navigation, flexibility, and efficiency of use (Soegaard, 2018; Johnson, 2020). To reduce users' mental and physical workload, the design should facilitate micro interaction and micro gestures (Bakker et al., 2016). Micro-interaction is a short-time interaction with a mobile device, making users operate with dexterity. The aims of micro gestures are to maintain the handgrip and move within the finger range, not to require moving the whole hand, and to reach the target on a mobile interface dexterously. Maher and Lee (2017) proposed the advantages of interaction design that exploited physical affordances. The tactile feedback from graspable devices provided additional information to construct a spatial map of objects and intuitive understanding. To reduce cognitive load, the design therefore should exploit available tangible cues effectively. Finally, the eyes-free interface design should facilitate users to competently interact without the need for visual attention. As a result, ten demand features in designing effective eyes-free interface configurations are summarised in the left column of Figure 5.3. These are 'easy to reach targets', 'easy to learn', 'promote micro interaction', 'lower error risk', 'less visual attention', 'easy to navigate', 'easy to remember', 'facilitate micro gesture', 'effectively exploit available tangible cues', and 'consistency of layout across devices'. The design tool of the quality function deployment (QFD) was applied in order to connect the determined needs of users to the functional requirements with a conceptual map in the House of Quality (HoQ). The central block of the matrix was analysed to set systematic thinking on design parameters. The functional qualities or requirements were proposed to serve the determined needs. This part shows the relationships between the needs and performance requirements. Each design requirement impacts on more than one functional requirement with three relationship levels, i.e., strong, medium, and weak. The result indicates the design effort that should be emphasised. After this translation of an abstract idea of demanded features to the functional requirements, certain design parameters relating to spatial memory and proprioception became obvious and were used in the ideation phase. The interface should be stable under fixed spatial relations. The interface area should be close to the reference frame and be within the finger range, because of providing essential information to the user's proprioception. The configuration of interface elements with regard to thumb motion under the mobile screen frame contributes to proprioception. In accordance with the effective stimuli from both tactile cues and proprioceptive cues, the alignment of targets that offer natural finger

orientation is suggested. The visual representation of interface configurations impacts spatial memory. Thus, the representation of structured configuration should be effectively provided within the reference frame and a symmetrical design is suggested. The number of targets, the target size, shape, target proximity, path characteristics, and interaction techniques should be appropriate. The responsive design should be applied for design consistency. Finally, the customisation feature should be applicable.

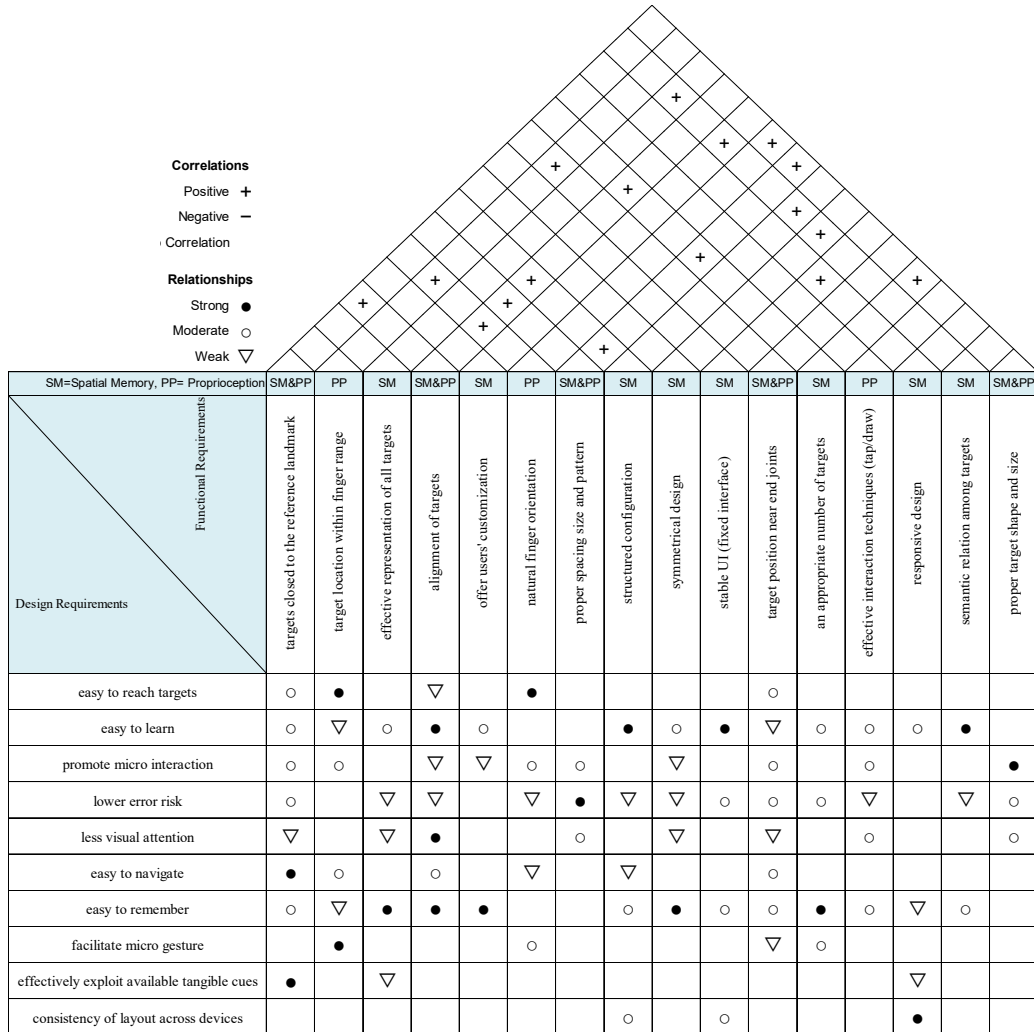

Figure 5.3 House of quality for eyes-free interface

Finally, the roof of the house or the correlation between functional metrics was established. These related factors influence spatial memory and proprioception affecting the eyes-free interface performance. For example, the interface area has a correlation with the alignment and the possible number of targets. On the other hand, the number of targets has a correlation with the target size and shape which relate to spacing size as well as spacing pattern, and affects the interface configuration and performance accuracy (spatial memory and

proprioception). The symmetry of the menu supports interface learning, semantic memory, and spatial memory. The interface configuration impacts spatial memory and finger orientation. Proprioception is affected by finger orientation, interaction technique, finger range, anchor point, and spatial memory. Thus, the method of designing prototypes should start with considering these design requirements and their relationships that impact performance accuracy under eyes-free interaction.

5.3 Conceptual design (First iteration)

After defining the demand qualities and functional requirements, many designs were generated and then reviewed in the following sections. This phase contains two iterations in designing prototypes: concept design and detailed design. Ultimately, the final prototypes will be tested in the experiments presented in the next chapter to gain clearer understanding of the effect of interface configuration on the performance accuracy of eyes-free interaction.

Various aspects of interface and interaction on a touchscreen device that influence eyes-free performance were considered. Firstly, the idea was toward the hand posture that related to the anchor position, finger range and degrees of freedom. When users were holding the mobile with one hand, they could directly approach the back and front of the mobile with mobility and flexibility under thumb opposition and coordination of thumb joints. This incident contrasts with interaction on a stationary mobile, touchpad on a control panel, or dashboard that can be approached from the front plane only. It was found that interacting on a handheld device with a single hand in the portrait mode is ubiquitous and popular, therefore the design prototypes in this research was proposed to apply, based on one-handed thumb mobile posture.

After the hand posture for interaction was defined, the location area, alignment, and orientation of the interface were considered simultaneously. The anthropometrics and ergonomics data were also used to consider designing the prototype effectively. Bergström-Lehtovirta and Oulasvirta (2014) proposed that the thumb functional area on a touchscreen in a one-handed posture is restricted within a parabolic curve whose covered range depends on the distance of the index fingertip from the device edge and handgrip position. Thumb width is ranging about 19.8 mm while thumb length is ranging from 49.2 to 72 mm (Sawyer and Bennett, 2006; Park and Han, 2010). It was found that the fingertip, rather than the finger pad (thumb width), provides the touch coordinate point on a screen (Xu et al.,2012). The reachable area under a fixed grip relates to the thumb length. This area covers around half of the screen height in the portrait mode. It was discovered that most of the users were unable to reach the whole area on the screen unless they repositioned the grip for the original menu interface. Repositioning the

handgrip would make the users lose the seamless experience as they had to pay attention to recalibrate the sense of space. Therefore, it had better adopt an interface on the thumb reachable area rather than using the whole screen area for dexterous operation and eyes-free interaction.

Depending on the size of mobile (Choi et al.,2020), the users may grasp the device at the middle part or the lower part. The anchor point of eyes-free interaction is at the handgrip position on which the metacarpophalangeal joint (MCP) or thumb knuckle joint secures (Figure 2.5, 2.6). Therefore, the most possible places for putting the interface include two areas: the upper part and the lower part of the screen.

Interface prototypes were then created with the different layout configurations. Only the layouts in Figure 5.4, including a curved layout in a radial pattern, a prong layout, a zig-zag pattern, and a square grid pattern, were selected for the test because they were assessed as easy to learn and navigate. All proposed layouts, including unselected ideas, were provided in Appendix 2. The curved layout was generated from the concept of a functional thumb area. Bergström-Lehtovirta and Oulasvirta (2014) illustrated that the thumb motion forms the parabolic area under an orthogonal area from the west across to the north direction. There are four targets in three rows that could be approached by folding a thumb and swiping with it for each level. The prong layout concept is derived from observing the thumb movement to different orientations on the screen. The targets are aligned straight along the thumb axis in each orientation by which the common position at the thumb knuckle acts as an anchor point for reference. The level of the three targets is put for three yaw angles. Lee et al. (2019) claimed that the diagonal direction between the upper right and the lower left side of the screen provides comfortable gestures for a right-handed person. As the MCP joint is anchored at the lower right corner, the thumb often points toward the upper left corner. Thus, the diagonal alignment pointing toward this direction within the prong layout was created (Figure 5.4b). The zigzag pattern was proposed by implementing the spacing pattern to lower the risk of unintentional tapping errors on the adjacent targets. The four targets are indented for two sets, so eight targets are in total. Finally, the straight alignment on the grid patterns was adopted due to being a common interface pattern that the targets line up parallels with the screen frame, making it more or less easy for the users to adapt for eyes-free interaction. There are three grid patterns, varied by the number of targets in each row and column. These layouts are the 4x3, 3x4, and 3x3 grids. The number of targets impacts the target size and spacing size under a limited square area. The more the number of targets, the smaller the target size and spacing size.

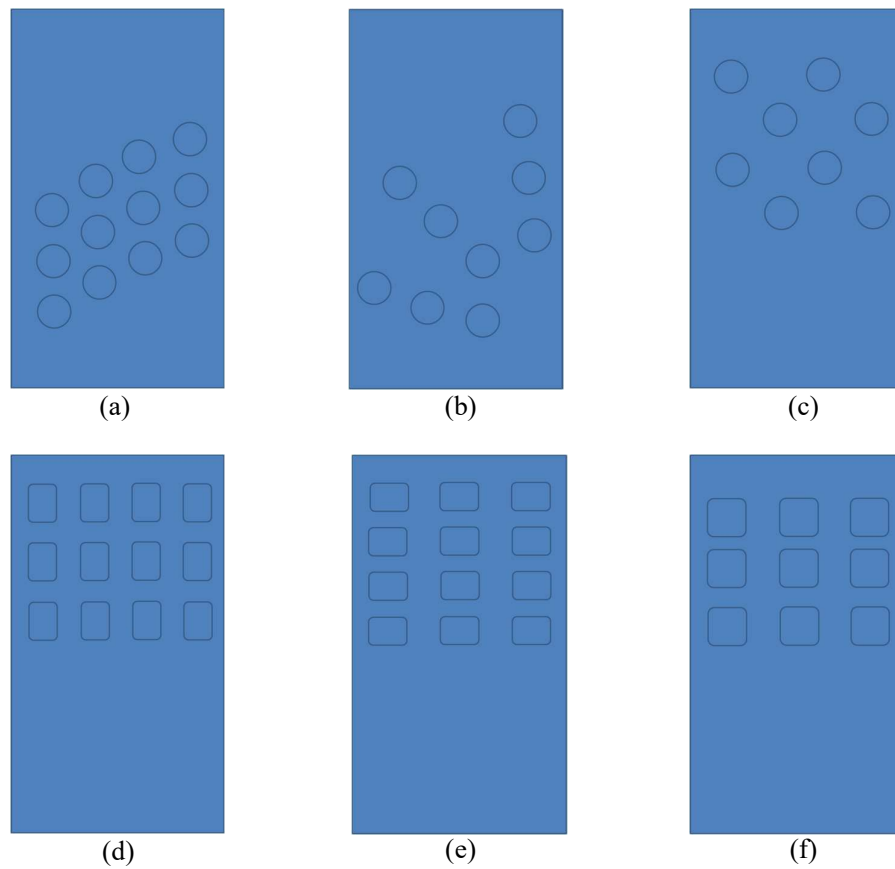

Figure 5.4 Paper prototypes in the ideation phase

The test was initiated by memorising the target positions in paper prototypes and drawing each layout over the mobile touchscreen in eyes-free mode. This preliminary test was performed by the researcher via the touchscreen test app downloaded from the Play Store (Figure 5.5) to explore these original ideas. This app provided the touch point on the mobile screen that made the researcher initially assess whether the interface configurations were proper for eyes-free interaction. Outcome samples of the touch positions for the test under this app were presented in Figure 5.6. All layouts vary the number of targets, location, alignment, and orientation. The testing results indicate that the curved layout provides comfortable gestures, orienting at different angles around the thumb knuckle. For the prong layout, it provides natural gestures, stretching, or folding gestures along the thumb axis at each orientation. The diagonal direction offers comfortable ergonomics for interaction.

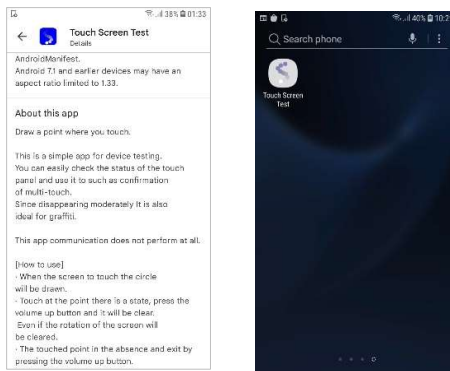

Figure 5.5 The touchscreen test app used during ideation phase

However, the interaction on the zigzag pattern requires multi strokes at variable angles to reach each target. This pattern also needs a reference to the nearest neighbours and the target positions cannot be divided conveniently. In other words, the users must change their gestures among the targets with sharp turns, therefore this approach is apparently far from the smoothness under dexterous operation or peripheral interaction.

The grid patterns provide good outcomes, except for the targets that are inside or far from the reference frame. The inner targets under the grid pattern demand much effort for position discrimination as these positions are away from the reference frame and, in consequence, the users rely solely on an inter-target coordination system. Moreover, it was found that the approach of targets in the upper row is more difficult than in the lower row because the functional thumb area is within a parabolic curve. In other words, adjustments for thumb stretch are needed to reach the targets aligning on the top edge. Thus, the upper row should not be applied for an eyes-free interface. The area near the bottom row on the handgrip level is more appropriate for interface configurations.

The number of targets under grid patterns was also examined. It was supposed that a design providing symmetrical structures could enhance user cognition such as the equal distribution or the equal number of the targets on the x-axis and the y-axis. In these cases, the users could transfer the spatial knowledge between the target positions and between the width and height coordinates. Therefore, the size and spacing of the targets should be uniform (consistent structure) and the interface layouts had better be put in a square area, providing a diagonal symmetry for accommodating different mobile orientations.

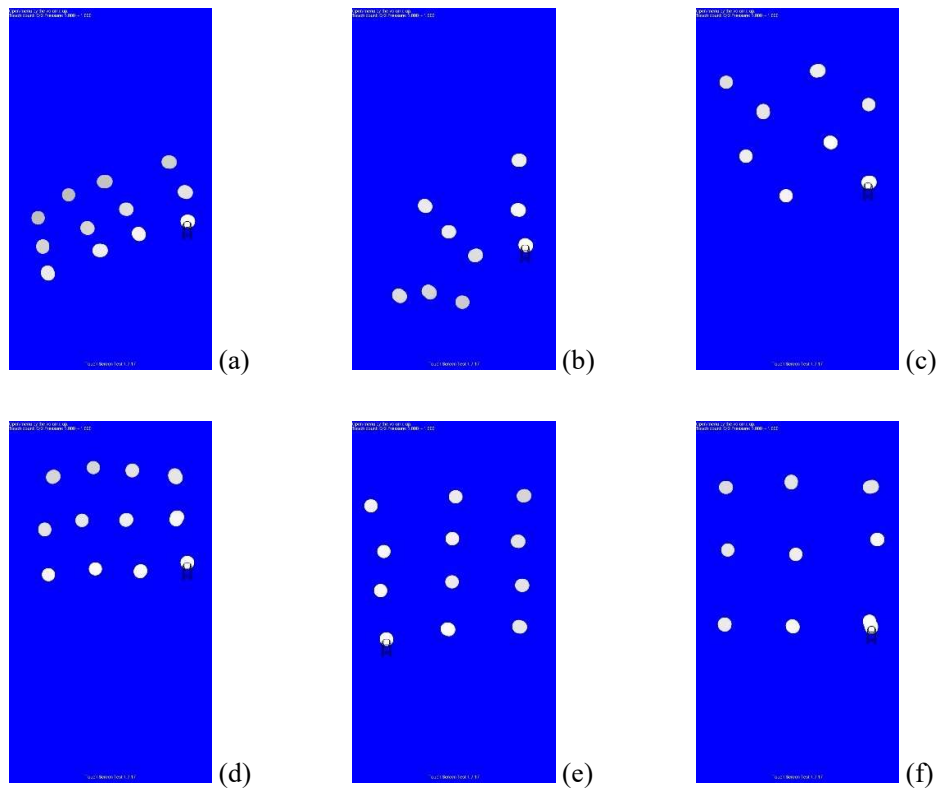

Figure 5.6 Testing on the touchscreen test app in the ideation phase

Choi et al. (2020) presented that the user's grip position and thumb knuckle are usually at the lower part. Moreover, the researcher observed the findings from the touchscreen test app and discovered that the handgrip position on the mobile device at the middle or upper part is often varied and floated as opposed to the bottom grip position. This is because there are no landmark or device cues provided at the middle of the screen. As a result, the lower half should be appropriate for placing the eyes-free interface layout.

To sum up, proper locations for putting eyes-free interfaces include the bottom row, sides, a diagonal line originating from the lower right corner, and a functional thumb curve around the thumb knuckle of the right-handed mobile users. These locations will support the eyes-free interfaces that could guide and help users onto the targets effectively.

Then the layout was optimised by anchoring the layout at the lower right corner and reducing the number of targets. Vandierendonck and Szmalec, (2011) proposed that the visuospatial working memory seems to be recalled better for the representation of four objects. Therefore, designing with four objects in each direction was chosen. To gain insight into the effectiveness of the interface configurations, the final concept of the eyes-free interface was then split into sub-elements for development in the detailed design phase. It consists of horizontal, vertical

left, vertical right, diagonal, and curved alignments. All elements relate to distance from the same anchor point at the lower right corner from the thumb knuckle. Figure 5.7 provides the proposed layouts with their pilot test outcomes. Indeed, the interface design could adapt and integrate these layouts together, depending on the number of objects needed in each application. Before moving to the detailed design of interface configuration prototypes, the next section will describe the creation and operation of the prototype system (screen data recording apparatus) to bring about a quantitative analysis of experimental data.

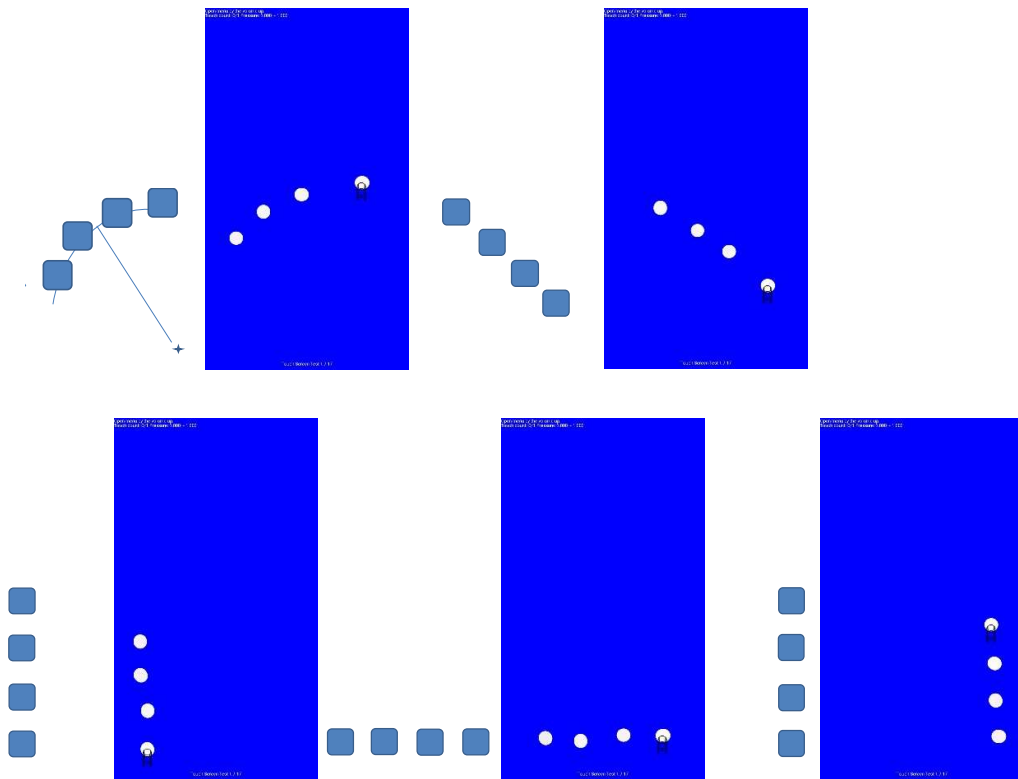

Figure 5.7 The final concept of experimental prototypes

5.4 Development of experimental apparatus (Screen recording app)

To obtain the performance accuracy measurement of interface configuration quantitatively, the data collection tool or experimental apparatus was created for the research. The screen recording app on touchscreen mobile with a responsive web application was developed for this research (Figure 5.8) so as to examine the participants' responses online in real-time. This would lead to a better observation of empirical data. The touch coordinates and other experimental data from the participants' mobiles were recorded and stored in a database. When accessing the app on their mobiles, the participants firstly met the main menu page displaying the list of steps in the experiments (Figure 5.8a). The screen would change to the canvas view

(Figure 5.8b) when any of the steps was selected by the participants. The touch coordinate for the pointing task would be presented on the canvas of each participant’s mobile while only the first position was displayed for the line drawing (Figure 5.8c).

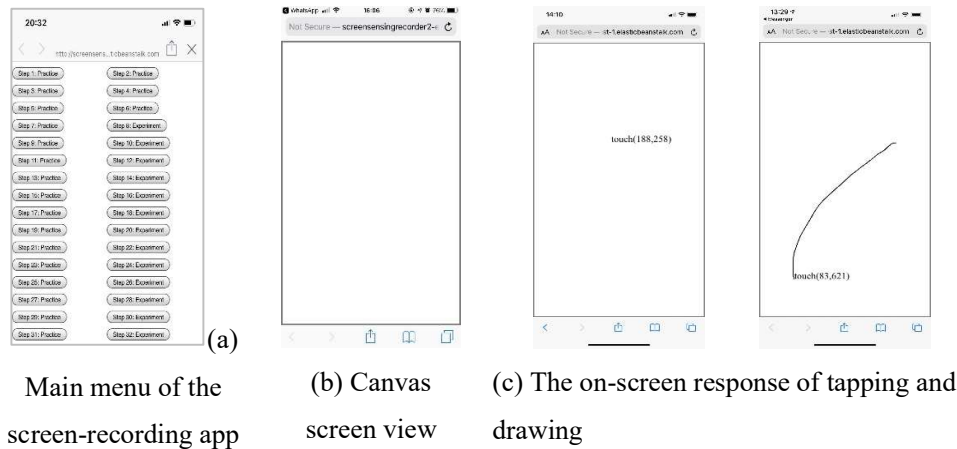

Figure 5.8 Experimental apparatus in this research

Meanwhile, another web page was also designed for the researcher to monitor and control the test on the desktop screen (Figure 5.9a). Ten categories of data were recorded during the test, including the participant ID, recording ID, recording status, the status of first on sequence, started timestamp, reaction timestamp, started timestamp in a millisecond, reaction timestamp in a millisecond, screen width and screen height, and the x and y coordinates of the touch position. As a result, the researcher could acknowledge and check each participant's touch events during the experiment. This app started recording the data when each participant touched the screen in the canvas screen view and the recording would be stopped if the finger was lifted. This action would be resumed when the touch action took place again. With the status of recording data being checked on the controller web page online, each touch action could be differentiated and the participants could be requested for corrective actions in real time, if necessary. The first touch of the task sequence would have a ‘true’ status, whereas the status for the remaining touch actions of the sequence would be ‘false’. Figure 5.9b illustrates the backend in JavaScript of MySQL system software for the screen recording app developed for this research. The details of the experimental protocol and web page access will be explained further in the next chapter.

| ID | STATUS | FLAG | START TIME | END TIME | COORDINATE 1 | COORDINATE 2 | TIME (ms) SINCE STARTED | RESPONSE |
|-------|--------|-------|-----------------------|-----------------------|--------------|--------------|-------------------------|-----------|
| 14374 | SAVED | false | 2021-02-17 14:36:35.0 | | 16135725951 | 412 x 783 | 11 | (111,697) |
| 14373 | SAVED | false | 2021-02-17 14:36:30.0 | | 16135725896 | 412 x 783 | 11 | (277,498) |
| 14372 | SAVED | true | 2021-02-17 14:36:17.0 | 2021-02-17 14:36:23.0 | 16135725768 | 412 x 783 | 15 | (161,448) |
| 14371 | SAVED | false | 2021-02-17 14:35:51.0 | | 16135725509 | 412 x 783 | 10 | (128,721) |
| 14370 | SAVED | false | 2021-02-17 14:35:46.0 | | 16135725455 | 412 x 783 | 10 | (304,336) |
| 14369 | SAVED | false | 2021-02-17 14:35:41.0 | | 16135725409 | 412 x 783 | 11 | (354,446) |
| 14368 | SAVED | false | 2021-02-17 14:35:36.0 | | 16135725356 | 412 x 783 | 13 | (112,732) |
| 14367 | SAVED | false | 2021-02-17 14:35:30.0 | | 16135725304 | 412 x 783 | 10 | (227,603) |
| 14366 | SAVED | false | 2021-02-17 14:35:26.0 | | 16135725255 | 412 x 783 | 11 | (312,469) |
| 14365 | SAVED | false | 2021-02-17 14:35:21.0 | | 16135725206 | 412 x 783 | 10 | (234,608) |
| | | | | | | | 13 | (304,361) |
| | | | | | | | 62 | (297,384) |
| 14364 | SAVED | false | 2021-02-17 14:35:16.0 | | 16135725155 | 412 x 783 | 80 | (294,385) |

(a) Controller web page on the experimenter’s desktop screen

| id | action_set_id | action_type | x | y |
|----|---------------|-------------|-----|-----|
| 4 | 4 | 1 | 302 | 466 |
| 3 | 2 | 1 | 315 | 442 |
| 4 | 2 | 1 | 315 | 442 |
| 5 | 2 | 1 | 337 | 410 |
| 6 | 3 | 1 | 370 | 376 |
| 7 | 3 | 1 | 413 | 344 |
| 8 | 3 | 1 | 475 | 314 |
| 9 | 3 | 1 | 536 | 295 |
| 10 | 3 | 1 | 568 | 290 |
| 11 | 3 | 1 | 600 | 263 |
| 12 | 4 | 1 | 161 | 40 |
| 13 | 5 | 1 | 16 | 69 |
| 14 | 6 | 1 | 308 | 63 |
| 15 | 7 | 1 | 176 | 144 |
| 16 | 7 | 1 | 173 | 154 |
| 17 | 7 | 1 | 173 | 162 |
| 18 | 7 | 1 | 173 | 175 |
| 19 | 7 | 1 | 175 | 180 |
| 20 | 8 | 1 | 178 | 190 |
| 21 | 8 | 1 | 180 | 195 |
| 22 | 8 | 1 | 182 | 200 |
| 23 | 8 | 1 | 185 | 203 |
| 24 | 8 | 1 | 187 | 222 |
| 25 | 8 | 1 | 190 | 238 |

(b) The backend database of MySQL system software

Figure 5.9 The software development system to record data in the experiments

5.5 Detailed design (Second iteration)

In the previous section, the experimental apparatus developed is available to measure numeric data output. After the interface configuration has been considered for the number of buttons, structured and symmetrical pattern, alignment, orientation, and target area in the conceptual design stage, this section presents further interface configurations in detail, which include the button size and shape, button proximity, sequence of the menu, and distance from the landmark. The button proximity refers to the spacing pattern or the button segmentation.

There are various target shapes applied on the touchscreen interface. Tao et al. (2019) studied the effects of keyboard size, gap, and button shape on accuracy rate and task completion time

for the one-handed thumb interaction with a mobile touchscreen. The results show that the button shape and gap impact on task completion time. The circle-shaped button provides a higher rate of accuracy than the button with the square and rectangular shapes. Thus, the interface configurations in the final stage apply the circle button shape. These prototypes are constructed in different orientations, consisting of horizontal (H), vertical left (VL), vertical right (VR), diagonal (D), and curved (C) layouts (Figure 5.10). The effectiveness of these layouts will be examined for spatial discrimination in the two experiments in the next chapter.

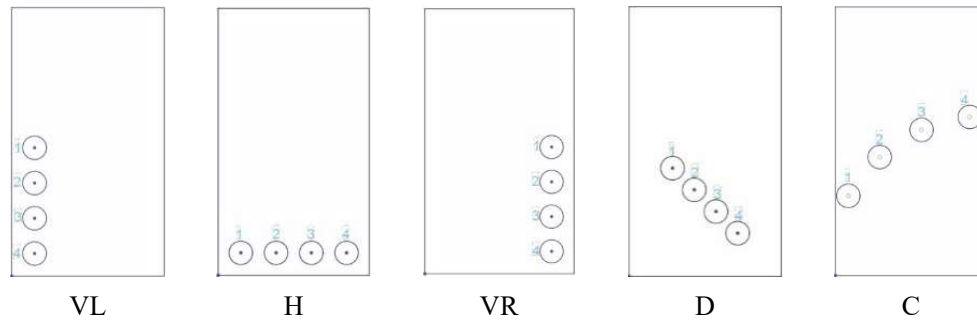

Figure 5.10 Layouts of eyes-free interface prototypes in different orientations

To facilitate the working memory, the path length should be short, and the choice of the paths should be familiar and logical (Smirni et al., 1983). Consequently, each layout in the final prototyping consists of four buttons aligned sequentially from left to right or top to bottom. In addition, these layouts are configured within a reference frame and represented with the 16:9 aspect ratio, which is the most common aspect ratio used on smartphones (Sodiq Olamide, 2019). Thus, the dimension of 90 units in width and 160 units in height were given for the reference frame of the designed prototypes while a diameter of 14 units was defined for the button size.

In each layout, the targets have an equal distance apart. In spite of that, the gap is unequal among the layouts as they are placed in different locations, and consequently the available functional areas are different. The diagonal layout is aligned at 45° from the bottom-right corner, whose buttons are put at the central part. The curved layout is constructed at a certain radius, whose buttons are put on the circumference at different yaw angles. The vertical and horizontal alignments are the periphery area of the grid layout in the U-shaped pattern. The horizontal layout provides the vertical symmetry feature. The horizontal layout also has a diagonal symmetry in conjunction with the vertical layout providing that Button 4 in the horizontal layout is in the same position as the vertical layout. The buttons in the curved layout were aligned with the equal angle distribution. The distance from the landmark or threshold

range of the buttons in each layout is derived from the response outcomes from the participants in the pilot test. The researcher hypothesised that participants might be more accurate in reaching the target in a horizontal layout than in a vertical layout due to a shorter interaction range. Performance might be more accurate in reaching the target near the base or the screen frame than in reaching the target that is far or within the upper part. Moreover, the general questions were addressed on how well the VL layout (far side) was, compared to the VR layout (close side), and how well the spatial discrimination was in a curve line and the diagonal line.

It was found that the typical mobile interfaces (Figure 2.10) are usually four or five buttons aligned vertically. Under the identical interaction area and button size, the five buttons interface results in a smaller button spacing compared with the four-buttoned interface.

Considering the effect of the odd and even points for eyes-free discrimination, it was supposed that the interface with odd number points may have had higher accuracy on average than the one with even number points because the middle position could be an additional reference point (Lin et al., 2011). The researcher supposes that the middle position may be advantageous for interaction in eyes-free mode.

To compare the effect of the middle position on an eyes-free interaction performance, the pilot test was conducted to examine how well participants map the spatial location halfway from the side edge of the touchscreen device. By adopting the screen recording app developed for the research, this experiment allowed the participants to use their personal phones for testing eyes-free interaction.

Under the pilot test, it was found that participants could memorise the interface configuration, map the position from their spatial memory, divide the middle position, and tap on the touchscreen interface accurately through proprioceptive awareness in eyes-free interaction. Figure 5.11 shows the result and the proof-of-concept of the eyes-free interface. It can be seen that the middle position could be another reference cue for eyes-free interaction. As a result, the divided patterns were further constructed to test performance accuracy for eyes-free interaction.

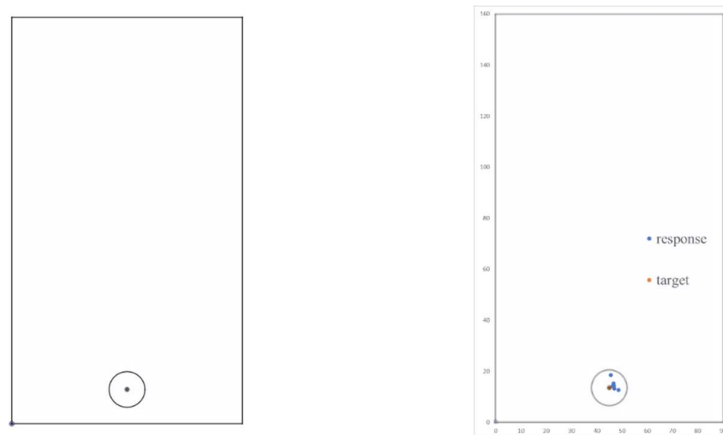

Figure 5.11 The representation of interface configuration and response of the pilot test

The divided pattern layout (Div) consists of a (dashed line circle) middle reference button and a group of two buttons on each side of this point. As the number of buttons increases from four to five buttons, the boundary buttons are further extended close to the frame while buttons are also evenly spaced from the middle point, making the button gap decrease in size as opposed to the normal layout. However, the spacing between the buttons in the curved layouts is the greatest spacing gap among all the layouts, enough for the middle dividing button, so the position of boundary buttons is not changed. The divided pattern will cause the upper button of the VL layout to be farther from the thumb reach and out of the functional thumb area, so it was not applied to the VL layout. The four layouts in the divided patterns which are H-Div, V-Div, D-Div, and C-Div layouts in Figure 5.12, are then added to the test. Thus, the experimental prototypes now have two patterns with different button proximity referred to as the spacing pattern or the button segmentation. Figure 5.13 shows the button positions of divided patterns in comparison with those of normal layouts.

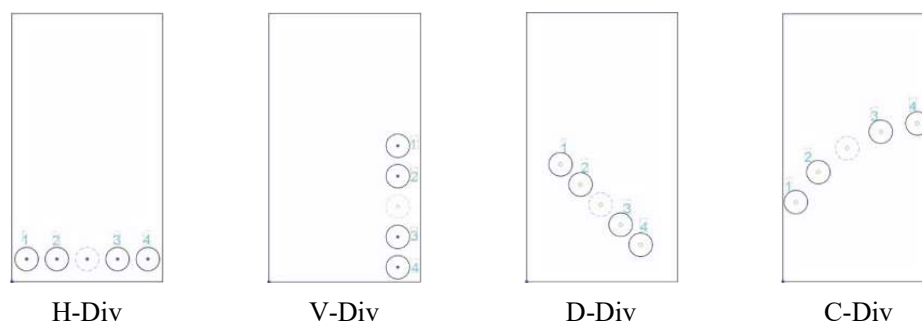

Figure 5.12 Layouts in divided pattern

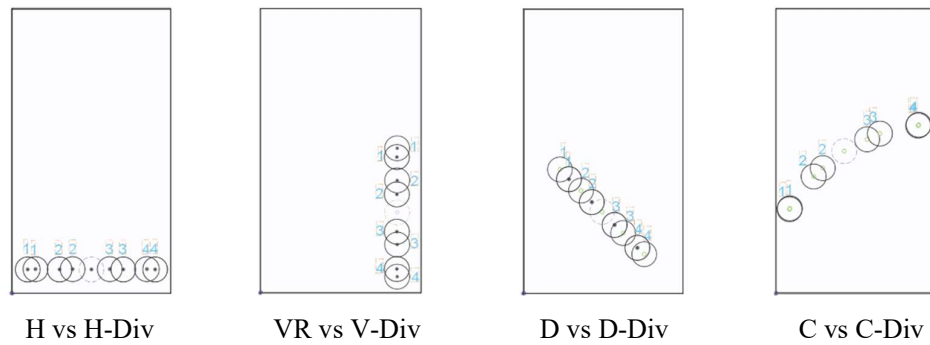

Figure 5.13 The comparison of button proximity between normal and divided pattern layouts

To understand the spatial memory performance better, the line drawing layouts were also designed (NK and Telles, 2004). These require different interaction techniques from the pointing tasks. They consist of the V-Line, H-Line, D-Line, and C-Line layouts. The V-Line layout requires space discrimination akin to the horizontal button layout. The H-Line layout also has a matched position with the vertical button layout. As approaching from angles was less precise than localising a target in-depth direction (van Beers et al., 2002), the diagonal and curved drawing layouts were designed to contain merely three lines. Figure 5.14 illustrates the spatial discrimination of the button layouts in comparison with line drawing layouts.

All the layouts were designed and refined under thorough review from the pilot testing and had distinct characteristics, alignment, orientation, spacing pattern, and location area. The outcomes from these prototypes would be expected to provide the researcher with insights into the effectiveness of interface configuration for eyes-free interaction.

Finally, two layouts of unstructured patterns (Figure 5.15) were constructed for comparing the effect of previously developed structure layouts on spatial memory and proprioceptive performance. Positions of buttons in these layouts are random. The sequence of buttons in the first layout (Un-1) was in the constant direction (clockwise direction). While the sequence of buttons in the second layout (Un-2) was intermittent, arranged from the left to right. The specifications of experimental prototypes are provided in Appendix 3.

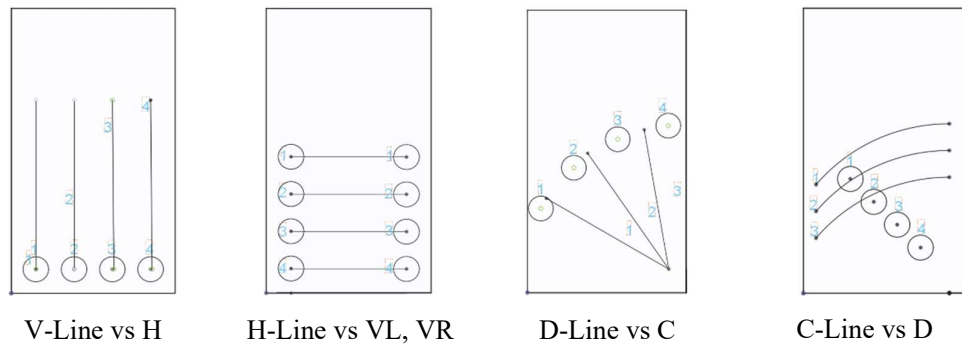

Figure 5.14 The spatial discrimination of the button layouts in comparison with line layouts

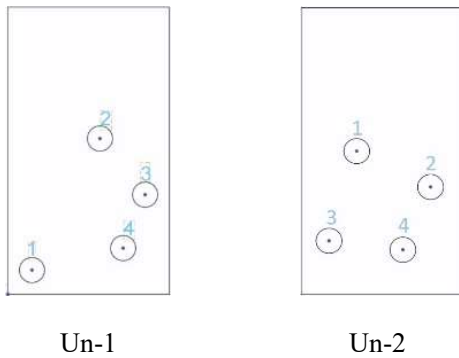

Figure 5.15 The unstructured layouts

5.6 Summary

This chapter consists of three main contributions: 1) the description of the novel spatial interface on a touchscreen for eyes-free interaction; 2) the proof-of-concept concerning how eyes-free interfaces work on touchscreen mobiles; 3) the design details of interface prototypes. The chapter portrays the design processes and tools for the prototype development of interface layouts. Finally, the fifteen final layouts to be tested for empirical experiments in the following chapter are processed.

Chapter 6 Understanding human spatial memory and proprioception of the eye-free interface to develop a design framework

In this chapter, the effect of interface configurations on performance accuracy is examined, which is caused by spatial memory and proprioception in dexterous and eyes-free touchscreen interaction. The interface configuration prototypes developed in the previous chapter, consisting of four alignments of the interface pattern and two levels of button proximity, were investigated by the experimental design. In addition, the line drawing layouts and unstructured layouts were observed for different interaction techniques and path characteristics. As a result, the human abilities to recall and tap or draw a gesture in precise spatial locations under interface configurations could be explored mutually. Based on understanding human spatial memory and proprioception, the design framework for eyes-free interface could be developed. This chapter presents two consecutive experiments so as to help deepen the understanding of the eyes-free interface and to answer RQ3 about the characteristics of interface configurations providing advanced performance accuracy. Experiment 1 was proposed to adopt the serial presentation of four frames to test how well the participants stored and retrieved spatial positions on separate layouts. In this study, the layout was presented in conjunction with the other layouts. As a result, the participants' attention was divided and competed among layouts for retentive spatial memory. Experiment 2 was designed to exhaustively examine proprioceptive acuity on each layout; therefore, the only single layout or unified layout was applied. Thus, the experiment setups are different from the presentation mode. It is interesting to note that both experiments required spatial memory and proprioception abilities to interact with the touchscreen in an eyes-free manner. In other words, this research examined the interaction effect between spatial memory and proprioception by applying the knowledge gained from previous studies that examined solely on spatial memory or proprioception. These explorations present the interaction effect of human perceptual, cognitive, and motor control abilities on the interface configurations under the eyes-free interaction.

The eyes-free interaction, occurring on the unseen interface, takes advantage of spatial memory and proprioception. The participants have to learn and build a mental map of the space by understanding the targets' spatial relationships, and transferring or translating their spatial knowledge, acquired from the indirect visual interface seen formerly on the desktop screen, in order to accurately tap at targets on the touchscreen. In this matter, the researcher supposes

that leveraging natural human capabilities both cognitive and perceptual skills can benefit navigation performance with a minimal workload.

This chapter is structured into five sections as shown in Figure 6.1, followed by a summary of the chapter. It starts with the design of the experiment, involving the experimental protocol, participants, data processing, and data analysis. After that, the task and procedure, and hypotheses of the descriptive study were explained, followed by its result. The descriptive study consists of two experiments to examine the role of interface configuration on spatial memory and proprioception. The discussion was made together between the two experiments, providing the analysis of all results. In addition, the interface configurations were analysed and discussed in order to draw out the implications for design. The design framework was finally established as a prescription for design in the last section.

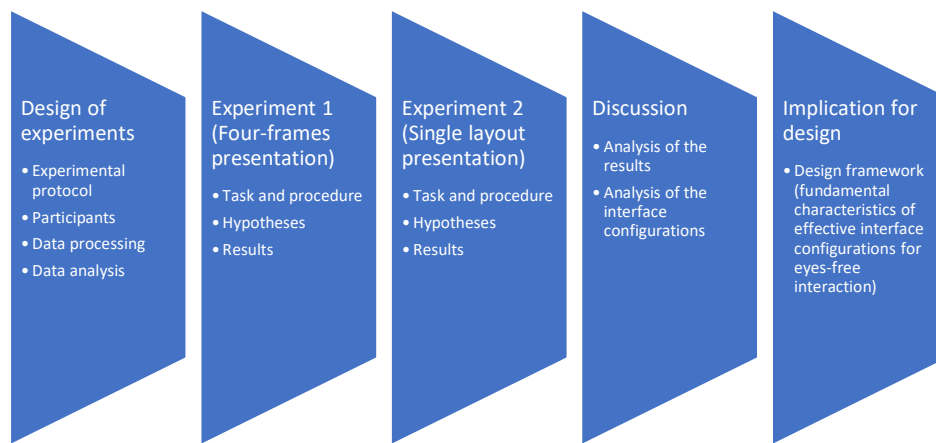

Figure 6.1 Structure of Chapter 6 showing sections and subsections for the overall study

This chapter contributes to the understanding of (1) the performance of novel spatial interfaces on a touchscreen, (2) the effects of different interface configurations on spatial memory and proprioception for one-handed thumb interaction, and (3) the framework derived from the experimental results identifying interface design characteristics to support this eyes-free interaction.

6.1 Design of experiment

The experiments were designed to test and observe the effect of different interface configurations on spatial memory and proprioception for one-handed thumb touchscreen interaction in the absence of vision. Therefore, the experimental tasks required the participants to respond to the provided sound stimulus speaking the target positions in series by interacting

with the spatial interface on a touchscreen mobile in eyes-free mode. With the non-visual interaction, the sound stimulus was used on purpose to assign participants the command to respond to tasks on each test consistently.

The experimental apparatus developed in the previous chapter was used to collect accurate and reliable data on the participants' responses. The responsive web application was constructed on an HTML canvas at the front with a sound stimulus speaking the numbers in a sequence of target positions (experimental commands). This app detects data with touch and line drawing actions taken by the users. The front end sends the action record every 10 milliseconds to the backend. The main page on the touchscreen mobile showed the list of steps in the experiments. After the participants entered each step, the screen was changed to a canvas view with a sound stimulus. Figure 6.2 (a) shows the pages of the responsive web application before and after selecting the step for the test.

Before the experiment, the setup and method was optimised through a pilot study test. The pilot study showed that the sound gap of 5 seconds and 8 seconds was enough for the participants to respond to the tapping and drawing tasks respectively. In each step, the audio stimulus in the app spoke the number to inform the participants of the task. The numbers were among 1-4 or 1-3 in random order. Each number in the sequences was repeated 3 times. Thus, the audio stimulus for the test consists of 12 sequences for the 4-positioned tasks and 9 sequences for the 3-positioned tasks. The sequence was pre-selected to control the order effect. The cognitive test performance might be influenced by repeated exposure to the spatial sequences from a single sound command (practice effect). In order to reduce the practice effect and avoid any possible sensitization problem, the sequence was switched between two sets.

In the screen-recording app, the timestamp and position on the screen where the participants touched were logged in the form of time series and (x, y) coordinates. The screen width–height of the participant's mobile was also recorded. The recorded data were stored in a database for further analysis. There is another web page designed for the experimenter to control the tests as well. This page could load and visualise the recorded data in real time (Figure 6.2 (b)).

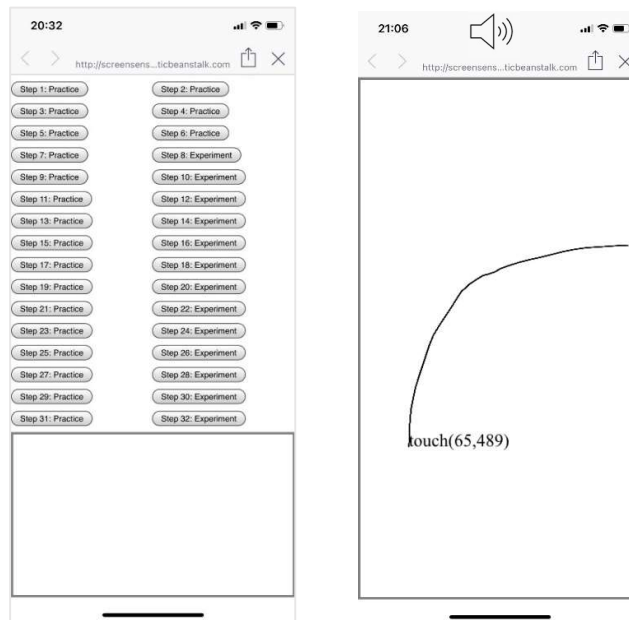

(a) Responsive web application on a touchscreen mobile

| Recording Id | Status | First on Sequence | Started Timestamp | Reaction Timestamp | Started Timestamp (ms) | Reaction Timestamp (ms) | Screen Width / Height | Action Sets |
|--------------|--------|-------------------|-----------------------|--------------------|------------------------|-------------------------|-----------------------|---------------------------------------|
| 12211 | SAVED | false | 2021-02-13 18:40:40.0 | | 16132416399 26 | 16132416399 26 | 375 x 603 | Time (ms) since started: 10 (137,199) |
| 12210 | SAVED | false | 2021-02-13 18:40:35.0 | | 16132416347 62 | 16132416347 62 | 375 x 603 | Time (ms) since started: 11 (272,283) |
| 12209 | SAVED | false | 2021-02-13 18:40:30.0 | | 16132416298 96 | 16132416298 96 | 375 x 603 | Time (ms) since started: 10 (114,486) |
| 12208 | SAVED | false | 2021-02-13 18:40:24.0 | | 16132416244 28 | 16132416244 28 | 375 x 603 | Time (ms) since started: 10 (131,238) |
| 12207 | SAVED | false | 2021-02-13 18:40:19.0 | | 16132416191 75 | 16132416191 75 | 375 x 603 | Time (ms) since started: 11 (240,495) |
| 12206 | SAVED | false | 2021-02-13 18:40:15.0 | | 16132416153 95 | 16132416153 95 | 375 x 603 | Time (ms) since started: 10 (125,477) |
| 12205 | SAVED | false | 2021-02-13 18:40:10.0 | | 16132416099 78 | 16132416099 78 | 375 x 603 | Time (ms) since started: 10 (255,502) |
| 12204 | SAVED | false | 2021-02-13 18:40:05.0 | | 16132416050 45 | 16132416050 45 | 375 x 603 | Time (ms) since started: 10 (290,302) |
| 12203 | SAVED | false | 2021-02-13 18:40:01.0 | | 16132416010 80 | 16132416010 80 | 375 x 603 | Time (ms) since started: 10 (246,509) |

(b) Controller web page on a desktop screen

Figure 6.2 Experimental apparatus

6.1.1 Experimental protocol

Under the concept of eyes-free interaction, the smartphone is used as a peripheral device for seamless integration into real-world tasks without shifting visual attention back and forth between the mobile device and the real world (Morris et al., 2011). Thus, the visual interface will be presented to the participants to memorise before performing any interactions. Spatial memory will aid the participants in guiding the thumb motion to the target positions without visual feedback as they will be unable to observe the on-screen mobile interaction.

The serial presentation of the four-framed layouts was adopted in Experiment 1 to test the participants on which layout or target position could be stored and retrieved spatial positions better, whereas the single layout presentation was applied to Experiment 2 in order to test the performance accuracy for each layout directly. In addition, the unstructured layouts would be compared between both experiments to test the participants on which presentation mode could be stored and retrieved spatial positions better.

A repeated-measures within-subjects design was used. That is the participants are exposed to every condition exactly like each other. The independent variables were interface configurations and modes of presentation. The measurements were made on a single identifiable population (dependent samples). Therefore, all the participants took part in both of the experiments. Those who were touchscreen mobile phone enthusiasts were invited via university channels and social media.

These experiments were conducted online via the participants' mobile together with a Zoom meeting on a desktop display. Participants were requested to complete the tapping and drawing tasks on their own touchscreen mobiles. The interface layouts were equipped on the desktop screen to guide them before performing the task on the canvas mobile touchscreen under the bespoke screen-recording app. With the responsive design of the screen-recording app, the interface area could fit in the available space of various mobile models. A short practice session was provided to help familiarise them prior to entering the test session. The participants interacted with their touchscreen by using the thumb of their dominant hand while holding the mobile in the portrait mode.

The protocol started with the experimenter introducing the study detail to the participants via the presentation slide in the Zoom meeting, following with a short interview regarding their handedness and experience with mobile phones. After that, a check was carried out for the audio stimulus on the mobile and the synchronisation of the data on the controller web page. During each experiment, the participants were required to perform a short practice before entering the actual test session, and the graphic interface was controlled via a remote slide presentation. During the test, their glances were monitored manually by the researcher and the recorded data were monitored through the controller web page. Each experiment had 15 slides of the graphic interfaces and took around an hour from start to finish, including short feedback questions about the easiness of interfaces. It was found that muscle memory involves procedural memory through repetition and supports skill performance. Lu et al. (2017) demonstrated that muscle memory referred from proprioception and transferred with practice and experience can support eyes-free interaction. To release muscle memory and mental

fatigue, Experiment 2 was therefore conducted separately, usually around a day later, depending on the availability of the participants. Figure 6.3 shows the protocol for both experiments.

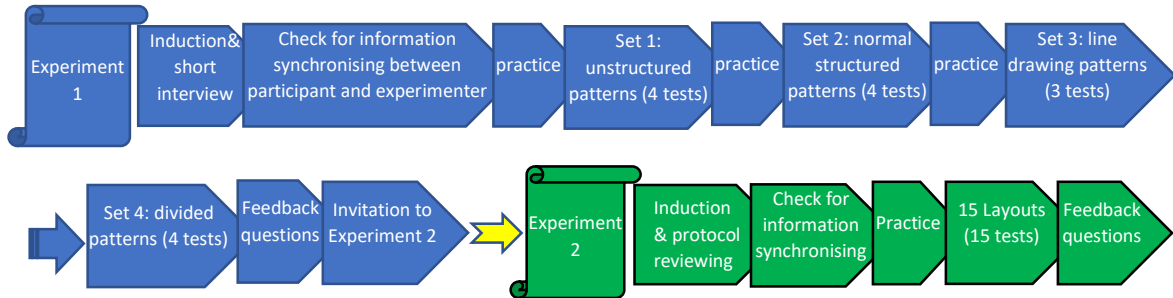
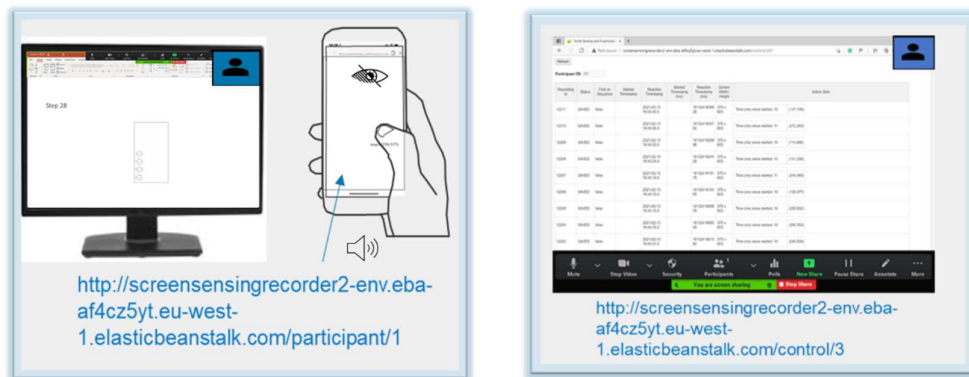

Figure 6.3 Experimental protocol

During the learning and practice phase, a picture of the layouts was presented and would be visible to the participants for about 50 seconds, then disappeared from the screen. After that the experimenter moved the desktop screen to the controller web page while the participants were tapping on the menu of the screen-recording app to initiate the audio command on the test. Figure 6.4 presents the difference between the desktop screen during the learning and practice session and the test session. The experimenter asked participants to listen to the audio stimulus that was speaking the number for a task, and to interact as much accurately as possible with the number location heard from their spatial memory without looking at the touch screen. Thus, the interaction on the mobile relied on spatial memory and proprioception during the test session.



(c) Learning and practice session

(b) Desktop screen during test session

Figure 6.4 Experimental setup

Spatial memory and proprioception could be explored and measured indirectly via task performance under the control condition in each experiment. Under one-handed thumb interaction, the bottom right corner of the screen on which the thumb knuckle was placed, was defined as an anchor of the proprioception. The outcome was presented with the touch coordinate. The position would then be compared to the target coordinate. Performance accuracy was analysed out of the mean distance error from the target position. The higher the mean distance error, the poorer the task performance.

Although the recorded data consists of touch coordinates and timestamps to measure the spatial accuracy and latency of participants' responses, this research will solely report on the performance accuracy. This is because the interface design was aimed at dexterous operation. Thus, the reaction time was assigned and restricted by the pace of the audio stimulus during the test. Participants must respond to the audio stimulus of each target within a limited time as the next stimulus sequence would be presented in order. In addition, the results from the pilot test have not revealed a significant effect of layouts on the reaction time.

6.1.2 Participants

There were 22 right-handed participants (12 female, 10 male) who were voluntary to the study. They were between the ages of 26 and 42 (mean=34, SD=5.2) and speak a language whose written form goes from left to right. Moreover, those participants use different models of mobile phones with 10 different screen sizes from 4.7 inches to 6.7 inches. The screen width ranges from 67.0 mm to 78.1 mm. The screen height ranges from 138.1 mm to 165.4 mm. The average aspect ratio of the participants' mobile screens was around 1:1.69, ranging from 1:1.43 to 1:1.90, which was equivalent to the aspect ratio of the imaginary layout interface (1: 1.78) in portrait mode. All the participants who were familiar with their touchscreen mobile were used to single-handed interaction, and their experience with their current mobile was from 1 month to 5 years, around 1.5 years on average. Although some participants with large mobiles prefer two hands or the cradle posture with one hand to touch the screen and two hands holding the mobile, everyone easily adopts one-handed thumb interaction for the experiments.

6.1.3 Data processing

According to the proportion-based grid under the responsive web design, the same button in different mobile sizes has a different distance (mm) from the screen edge. Thus, the research participants had to map the position within the canvas screen (interaction area) of the screen-recording app under their own mobile sizes. To make the data comparable among the participants, the mean distance error in relative units was used with respect to the square interface area of 90 units in length (the interface occupying the lower screen area only) without

referencing the actual distance (mm) on the specific phone model. Therefore, the aspect ratio of the screen would not affect the outcome data as the interface or interaction area would not occupy the whole screen height. In other words, the screen height relating to the aspect ratio does not matter.

Therefore, all the touch coordinates recorded from each participant's mobile screen dimensions were transformed into a common unit by the proportion of the screen width. Details of the data processing method are provided in Appendix 4. The common coordinate system has referred to dimensions of interface prototypes under the 90-width and 160-height frames.

In this research, the difference between the touch position (response outcome) and the target centre position is referred to as the displacement error. The displacement error was calculated as the Euclidean distance (the shortest distance to the target position) through the Pythagorean theorem. The absolute (unsigned) value is used to compare the level of distance error. The smaller the level of distance error, the higher the level of spatial acuity. The outliers whose trial positions are away from the mean position by at least three standard deviations will be removed from the data analysis.

As the coordinates of a line are a series of points, certain data of each line was used instead to evaluate the response outcome of the line drawing layouts. To exemplify, the average of y-coordinates in a horizontal line is the outcome data of the H-Line layout. The average of x-coordinates in a vertical line is the outcome data of the V-Line layout. The angle was measured for the outcome data of the D-Line layout. It has a range of 90° around the bottom right corner, so the angle acuity can be used compared to the mean distance error under a range of around 90 units of interface size as well. Lastly, the y-coordinate of a curved line intersecting at axis $x=70$ is the outcome data of the C-Line layout. From these approaches, the mean error of the line drawing can be calculated.

6.1.4 Data analysis

The mean error of response outcomes was used for analysing the performance accuracy. Descriptive statistics such as mean (d) and standard deviation (SD) were used to examine the central tendency and variability of the measured variables. From the central limit theorem, it was found that the sampling distribution of the mean is always normal for larger sample sizes (Montgomery and Runger, 2014). As the sample size in this study is larger than 20 and there are three repetitions for each position, thus results are unaffected by violations of normality. There are various methods available to test the normality of the continuous data, including

skewness and kurtosis. Data that have skewness less than 2.0 and kurtosis less than 7.0 will be considered a normal distribution (Curran et al., 1996). Therefore, the normality was tested with these descriptive statistics before doing the inferential statistical analysis. A paired t-test and one-factor repeated-measures ANOVA in Minitab 19.0 were used for analysing hypothesis testing for the normal distribution. These inferential statistics were computed at the 95% confidence level.

There are four steps in performing the hypothesis testing (Hinton, 2004). Step one is to formulate the null hypothesis which assumes that no statistical significance exists in a set of the given observations (All means are equal). Step two and Step three are to calculate the test statistics and the significance probability respectively. The final step is to decide whether to reject the null hypothesis. The probability values (p) range from 0 to 1. The probability of 0.05 is called the significance level. If $p < 0.05$, reject the null hypothesis (Not all means are equal). If $p > 0.05$, there is no evidence to reject the null hypothesis. Appendix 5 shows the supplementary calculating formula and the example of the analysis method.

In addition to measurement of the mean distance error on the button layouts, outcome trend and precision of line drawing layouts were analysed to evaluate the response precision. The trend and interquartile range (IQR) of the drawing outcomes were analysed with a boxplot to gain more insights. The +/- sign calculated from the median minus the target value informs about the trend. The plus sign means the response outcomes tend to be shifted up from the target value while the minus sign means the response outcomes tend to be shifted down from the target value.

6.2 Experiment 1 (Serial presentation mode)

This experiment aims to explore human spatial knowledge and sensorimotor processes. It was designed to examine the effect of interface configurations in serial presentation mode on the performance accuracy in touchscreen eyes-free interaction. The independent variables for interface configurations were the pattern (normal and divided patterns), the structure (unstructured and structured layouts), the alignment (horizontal, vertical, diagonal, and curved layouts), and the button positions. The hypotheses were formulated and examined in a controlled experiment. The task performance or mean distance error is a dependent variable for hypothesis testing.

6.2.1 Task and procedure

Participants were faced with four separate frames of reference named from 1 to 4 (Fig. 6.5). There were 15 tests from 4 sets. Set 1 aimed to test for four unstructured patterns (Un-1 and Un-2 layouts, as well as the mirror of these layouts that were the Un-1M and Un-2M layouts).

The button positions in the four frames were from Button 1 to Button 4 respectively, for each unstructured layout. Thus, the effect of the serial presentation of the four frames would be investigated and compared to a single layout presentation in Experiment 2.

In each test on Set 2 and Set 4, the four frames of the button layouts were sequentially presented from the horizontal, vertical, diagonal, and curved alignments. In addition, one button in all layouts in each test was marked to test the spatial memory retention among the four layouts (the same button for every layout). Thus, there are four tests to cover all button positions (P1-P4). Each position gives a spatial difference for eyes-free orientation. To exemplify, among four buttons of the structure layouts, Button 4 has the shortest distance from the anchor point, followed by Button 3, Button 2, and Button 1 respectively, except in the curve layouts in which the distance from the anchor point is similar for all buttons (the same radius). However, Button 4 in the curve layouts is on the right side, much closer to the palm than other buttons. In this experiment, participants' attention was divided and competed among layouts for retentive spatial memory. It was supposed that the redundancy can be helpful to the participants for encoding and retrieving. Thus, the button alignment in structure patterns would improve task performance as opposed to the unstructured patterns. Participants must transform spatial positions of the buttons derived from four layouts into mental imagery in relation to each of the other buttons and interact with each position accurately on their mobile under a single reference frame, and must recognize that the audio stimulus in the task is from the frame name.

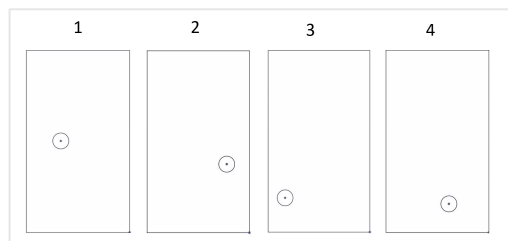

Set 1: Unstructured layout (positions from Un-2)

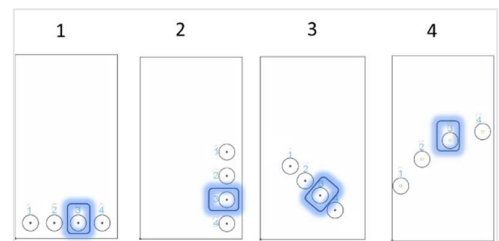

Set 2: Layout H, V, D, C with a mark on position 3

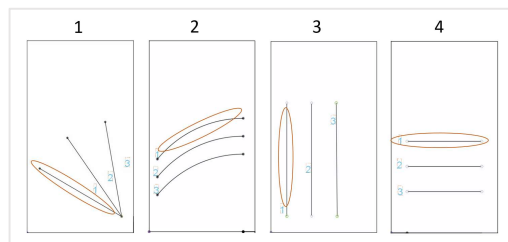

Set 3: Layout D, C, V, H with a mark on Line 1

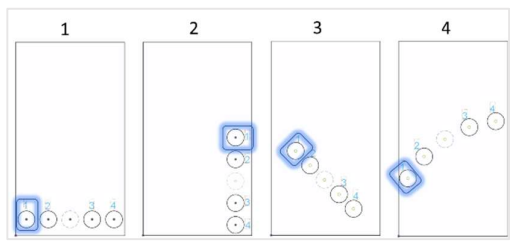

Set 4: Divided pattern layouts with a mark on Position 1

Figure 6.5 Samples of serial presentations of layouts for Experiment 1

In Set 3, line drawing layouts were tested. The layouts were sequentially presented from the diagonal, curved, vertical, and horizontal line patterns. This presentation was counterbalanced from the button layout to avoid sequence bias. As the diagonal and curved line layouts contain 3 lines, the V-Line and H-Line layouts were revised to remain 3 lines only for this experiment. Similarly, one line in all layouts in each test was marked to test the spatial memory retention among the four layouts (the same line for every layout). Thus, there are three tests to cover all line levels (L1-L3).

Figure 6.6 shows the mental images that the participants need to form for themselves for each test. To clarify in detail, in Set 2 and Set 4, Button 1 for each test is from a horizontal layout, Button 2 is from a vertical layout, Button 3 is from a diagonal layout, and Button 4 is from a curved layout. On the other hand, in Set 3, Line 1 for each test is from D-Line layout, Line 2 is from C-Line layout, Line 3 is from V-Line layout, and Line 4 is from H-Line layout.

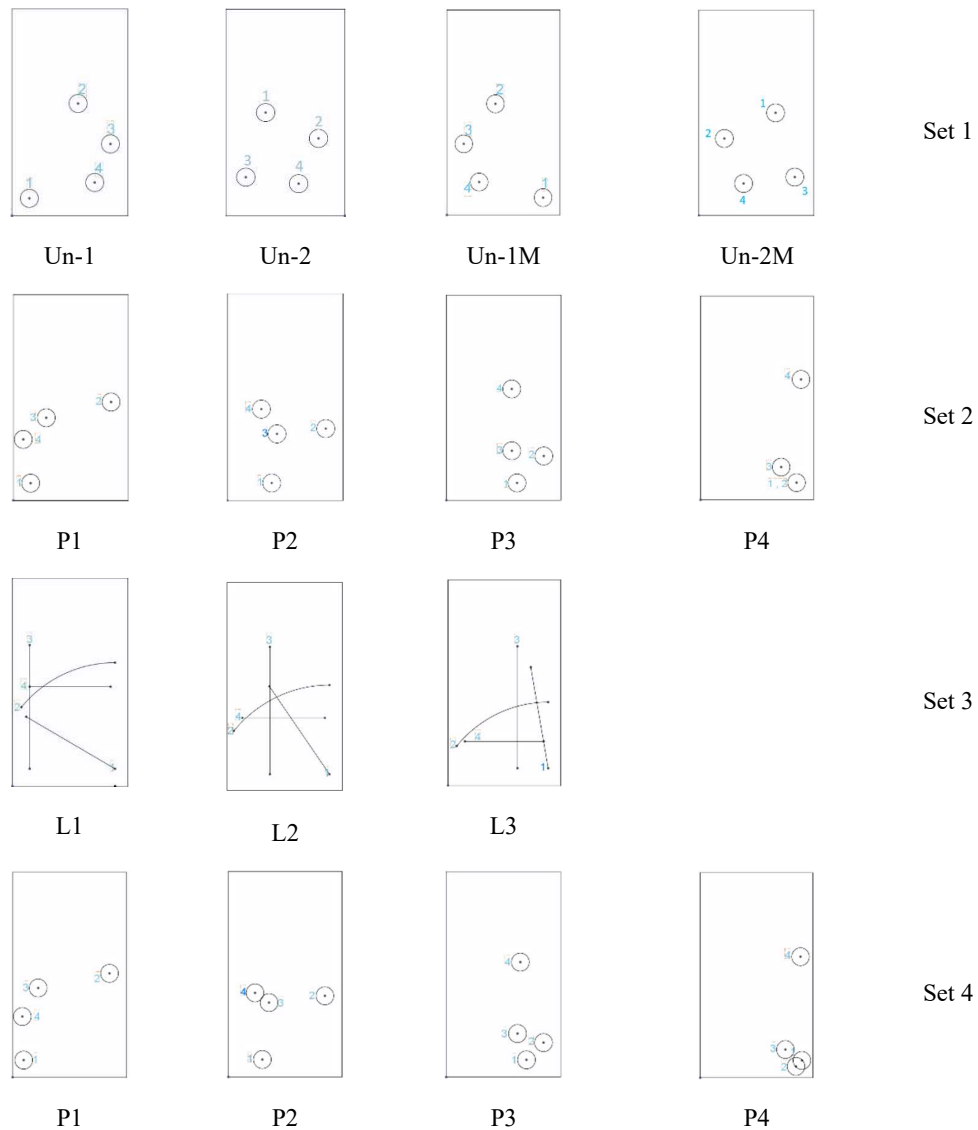

Figure 6.6 Illustrations of integration of spatial elements from four frames presentation

Participants needed to locate the touch position perceived from the structure patterns. During the test, the participants responded to the audio stimulus from their mobile by tapping or drawing on the mobile screen. It was supposed that certain spatial layouts could be a powerful trigger for recalling spatial memory. However, drawing a line requires a higher mental and physical workload than tapping a button, as a person needs to recognize and perform both drawing patterns and spatial location. It was supposed that the error from spatial memory would emerge clearly in the line drawing task because drawing provided a shape of the outcome. The mistakes of the pattern derived from drawing action could be discovered easily,

thus the percentage of line pattern error would be measured for task performance caused by spatial memory instead of the mean distance error in Set 3 of this experiment.

During the mobile interaction, the desktop screen was switched to the controller web page. Therefore, the interface layouts should have already been memorised before interacting. This encoded cognitive map is called an imaginary interface which must be still recalled in order to respond to the task accurately. When the tests had finished, the participants were asked to rank the layouts on their easiness levels while they did not know about their performance accuracy.

6.2.2 Hypotheses

There were four hypotheses proposed to investigate. The three hypotheses were tested in this experiment while the fourth one would be examined later, comparing results in Experiment 1 with results in Experiment 2.

H1: The position of buttons might impact spatial memory and task performance. Thus, with the difference in spacing pattern and exploitation of the middle reference cue, the button accuracy on divided pattern layouts is expected to have a different task performance from the normal layouts.

H2: The salience and the memory retention of horizontal layouts should be superior to other layouts under the multiple resource allocation. Consequently, the horizontal layouts are expected to provide better task performance.

H3: The structured patterns provide redundancy, facilitating recognition. Thus, the task performance on the structured patterns is expected to be better than the unstructured patterns.

H4: Simultaneous presentation of targets is more advantageous to spatial memory than serial presentation. Therefore, the performances of the unstructured patterns in simultaneous presentation mode or a unified layout are expected to be better than those in sequential presentation mode.

6.2.3 Results

The following sections present the results of the experiments consisting of outcome pattern and task performance, as well as the rating scales of the participants on easiness of interface layouts.

6.2.3.1 Outcomes and task performance analysis

There are 3,168 data points collected from 22 participants x 12 trials x 12 sequences of audio stimulus. The researcher removed 66 outliers (2.08%), leaving 3,102 data points in the performance analysis. In addition, there are 792 line-drawings collected from 22 participants x 3 trials x 12 sequences of audio stimulus. The data were processed and then the normality was analysed before doing the inferential statistical procedures. It was found that all data have skewness less than 2.0 and kurtosis less than 7.0; therefore, response data has a normal distribution. The experimental outcomes were shown in Figure 6.7 for the line drawing task.

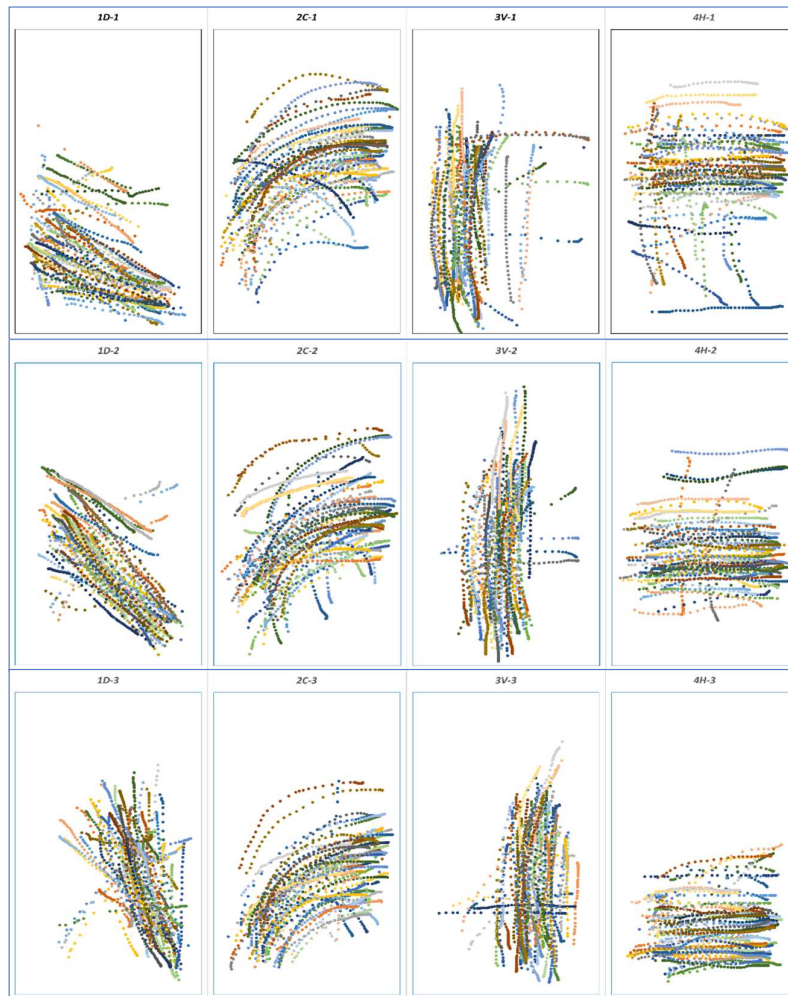

Figure 6.7 Line drawing outcomes in Experiment 1

The line drawing outcomes show many wrong patterns being drawn, for example, drawing a horizontal line instead of a vertical line, drawing a curved line instead of a diagonal line, and drawing a horizontal line instead of a curved line. Much information is also gained from this test such as the direction of motion, consistency, and line length. From in-depth data analysis

on the drawing gestures, it was found that among the participants there were both upward and downward drawing methods for a vertical line. Most participants drew a horizontal line from left to right and more than half of them drew a diagonal line outward from the common point. All the participants drew a curved line from left to right. These behaviours revealed the easiness of performing and the participants' familiarity. Table 6.1 shows the percentage of drawing error, calculated from the number of wrong patterns divided by the total number of lines drawn. It was found that the C-Line layout has the lowest number of pattern errors (6.1%). The highest number of pattern errors is in the V-Line layout (9.1%). Although the H-Line layout was the last pattern in the serial presentation, the correctness of the horizontal line drawing was still better than the vertical line drawing shown in the previous order. This implies that patterns in the horizontal direction related to an eye angle, e.g., C-Line and H-Line are good for memory retention.

Table 6.1 Errors in line drawing test on Set 3.

| Patterns | D-Line | C-Line | V-Line | H-Line |
|------------------------------------|--------------|--------------|--------------|---------------|
| Amount of line errors (L1, L2, L3) | 15 (6, 3, 6) | 12 (3, 4, 5) | 18 (7, 4, 7) | 16 (10, 3, 3) |
| Total number of line drawing | 198 | 198 | 198 | 198 |
| Percentage of error | 7.6 | 6.1 | 9.1 | 8.1 |

Figure 6.8 shows the experimental outcomes for tapping tasks in Set 1, Set 2, and Set 4 under serial presentation mode. The distance errors for all button layouts are included in Appendix 6. Touch positions for Button 1 to 4 are presented in blue, red, grey, and yellow, respectively. The tapping outcomes show the performance accuracy of structure layouts in Set 2 and Set 4, compared with the unstructured layouts in Set 1, and the button accuracy for normal layouts in Set 2 compared with divided pattern layouts in Set 4.



Figure 6.8 Outcomes on button layouts in Experiment 1

Task performance of unstructured layouts in Set 1 presented in Table 6.2. The descriptive statistics showed the mean distance error for each test position and overall layout. The overall mean distance error of unstructured layouts was 19.18 units. The repeated measures ANOVA showed a significant main effect of the mean distance error among the four layouts ($F_{3,21}=3.79$, $p=0.02$). The Un-2M layout was found having the highest mean distance error (22.39) while

the Un-1 layout had the lowest mean distance error (16.17). It was found that the sequence of buttons that is consistent in the same direction (clockwise direction) in the Un-1 layout provides a better performance than the button sequence that is intermittent, arranged from the right to left in the Un-2M layout.

Significantly, the mean distance error of Button 1 in the Un-1 layout was found different from other buttons ($F_{3,21}=6.69$, $p=0.00$), whereas the mean distance error among buttons on the Un-2, Un-1M, and Un-2M layouts was similar ($p>0.05$). The probable reason might be that Button 1 has a greater distance from the anchor point than the other buttons and is separate and far apart from the others.

Table 6.2 Mean distance error (units) of the unstructured layouts under serial presentation mode in Set 1

| | Un-1 | Un-2 | Un-1M | Un-2M | All layouts |
|----------|--------------|--------------|---------------|--------------|--------------|
| Overall | 16.17 (7.14) | 18.02 (5.87) | 20.16 (11.27) | 22.39 (9.82) | 19.18 (6.77) |
| Button 1 | 23.35* | 16.57 | 20.47 | 23.90 | |
| Button 2 | 16.82 | 16.05 | 15.90 | 20.16 | |
| Button 3 | 12.76 | 21.23 | 21.05 | 23.60 | |
| Button 4 | 11.75 | 18.23 | 23.20 | 21.90 | |

Note: SD is shown in brackets. * implies the button position having a significant difference in the mean distance error within the layout.

Task performance of the structured layouts in Set 2 (normal layouts) and Set 4 (divided pattern layouts) is presented in Table 6.3 and Table 6.4, respectively. As previously mentioned, Button 1 for each test is from a horizontal layout, Button 2 is from a vertical layout, Button 3 is from a diagonal layout, and Button 4 is from a curved layout. Therefore, the layout name is presented in each row in the table instead of the button name. The mean distance error was provided for all tests, layouts, and overall. The overall mean distance error was 16.89 units for the structured normal layouts and 15.86 units for the divided pattern layouts. The repeated measures ANOVA showed a significant main effect of the mean distance error among four tests (positions), in both the normal layouts ($F_{3,21}=4.17$, $p=0.01$) and divided pattern layouts ($F_{3,21}=4.79$, $p=0.01$). In the normal layouts, it was found that Test 4 or Position 4 provided the lowest mean distance error (14.41), followed by Position 3, 2, and 1, respectively. On the other hand, in the divided pattern layouts, Test 2 or Position 2 provided the lowest mean distance error (13.70), followed by Position 4, 3, and 1, respectively. Therefore, H1 is supported that the button accuracy on divided pattern layouts has a different task performance

from the normal layout. The divided pattern offers better performance accuracy on the button near the middle position. In addition, it was found that the button accuracy decreased with the distance from the anchor point and reference frame.

On the other hand, the repeated measures ANOVA showed a significant main effect of the mean distance error on layouts in Set 2 for each test ($F_{3,21}=8.76$, $p=0.00$ for Test 1, $F_{3,21}=4.04$, $p=0.01$ for Test 2, $F_{3,21}=5.21$, $p=0.00$ for Test 3, and $F_{3,21}=4.83$, $p=0.00$ for Test 4) and all tests, ($F_{3,21}=12.50$, $p=0.00$). The overall mean distance error on positions for H-layout (11.38) is substantially lower than V-layout (16.90), D-layout (18.03), and C-layout (20.85).

Similarly, the repeated measures ANOVA showed a significant main effect of the mean distance error on layouts in Set 4 for Test 1 ($F_{3,21}=7.25$, $p=0.00$), Test 2 ($F_{3,21}=3.95$, $p=0.01$), and Test 3 ($F_{3,21}=6.00$, $p=0.00$), and all tests, ($F_{3,21}=9.99$, $p=0.00$). The overall mean distance error on positions for the H-Div layout (11.35) is substantially lower than the V-Div layout (17.75), the D-Div layout (17.50), and the C-Div layout (16.86).

Overall, the horizontal layouts provided the lowest mean distance error. The experimental outcomes on the line drawing layouts also supported that the patterns in a horizontal direction related to an eye angle were good for memory retention. Thus, H2, where the horizontal layouts provided better task performance, was confirmed.

Table 6.3 Mean distance error (units) of normal structure layouts in Set 2

| | Test 1 (P1) | Test 2 (P2) | Test 3 (P3) | Test 4 (P4) | All tests |
|----------|--------------------|--------------------|--------------------|--------------------|--------------------|
| Overall | 18.91 (10.09) | 17.73 (8.39) | 16.52 (7.49) | 14.41* (5.61) | 16.89 (7.09) |
| Layout H | 12.03 ^a | 12.20 ^a | 11.40 ^a | 10.33 ^a | 11.38 ^a |
| Layout V | 18.44 | 19.51 | 16.46 | 12.54 | 16.90 |
| Layout D | 18.06 | 17.97 | 18.19 | 17.91 | 18.03 |
| Layout C | 26.72 | 20.58 | 19.75 | 16.34 | 20.85 |

Note: SD is shown in brackets. * implies the position having a significant difference in the overall mean distance error among all tests. ^a implies the layout that has the lowest mean distance error.

Table 6.4 Mean distance error (units) of divided pattern layouts in Set 4

| | Test 1 (P1) | Test 2 (P2) | Test 3 (P3) | Test 4 (P4) | All tests |
|--------------|--------------------|-------------------|--------------------|--------------------|--------------------|
| Overall | 17.57 (4.80) | 13.70* (3.81) | 16.76 (6.13) | 15.43 (4.48) | 15.86 (3.73) |
| Layout H-Div | 11.10 ^a | 9.66 ^a | 12.04 ^a | 12.33 ^a | 11.35 ^a |
| Layout V-Div | 19.39 | 14.65 | 20.96 | 16.00 | 17.75 |
| Layout D-Div | 17.62 | 15.30 | 19.32 | 17.78 | 17.50 |
| Layout C-Div | 22.19 | 14.94 | 14.72 | 15.60 | 16.86 |

Note: SD is shown in brackets. * implies the position having a significant difference in the overall mean distance error among all tests. ^a implies the layout that has the lowest mean distance error.

To investigate the effect of structure layouts closer, the repeated measures ANOVA was performed among the mean distance error of the unstructured layouts in Set 1 and the structured layouts in Set 2 and Set 4. The result showed a significant main effect on mean distance error ($F_{2,21}=3.38$, $p=0.04$), which confirmed H3 that task performance on the structured layouts was better than the unstructured layouts. The mean distance error for the unstructured layouts in Set 1 (19.18) was substantially higher than the structure normal layouts (16.89) and the divided pattern layouts (15.86).

6.2.3.2 Rating scales

The interview on the layout feedback shows that 17 of 22 persons prefer the normal structure layouts (77.3%) to the divided pattern layouts. Then the layouts were ranked on the easiness of the task from 1 to 4. Rating scales of the participants on easiness of interface layouts are shown in Figure 6.9. The mean scores on a dot-plot graph illustrate that the participants tend to give the horizontal button layouts the highest score for both button layouts (3.41) and line layouts (3.00). The second rank of their preference is the vertical layout, followed by the curved and diagonal layouts.

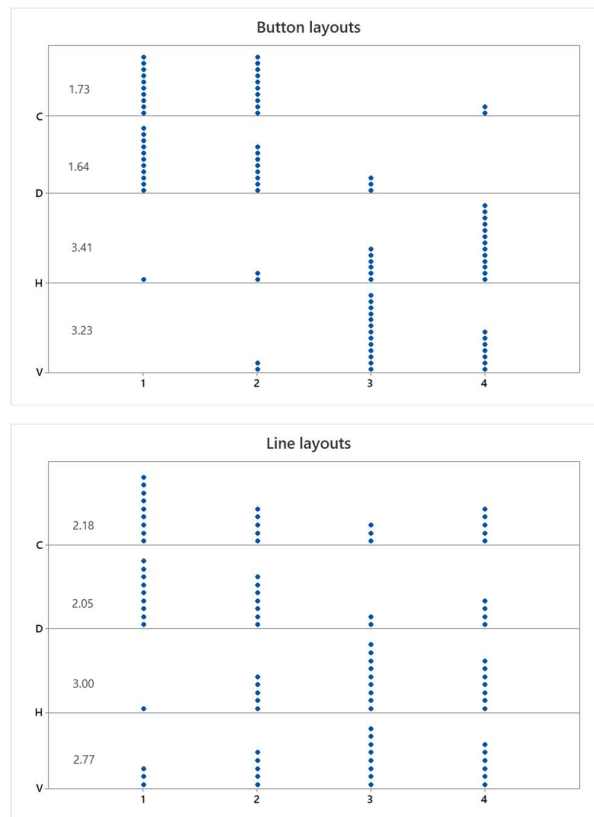

Figure 6.9 Layout ranking in Experiment 1

6.3 Experiment 2 (Single layout presentation mode)

This experiment aims to measure the spatial acuity levels between the buttons or lines for each layout and to examine the performance accuracy of different interface configurations and the modes of presentation on the performance accuracy in touchscreen eyes-free interaction. The independent variables for interface configurations include the button or line positions for each layout, the interaction techniques (tapping and drawing), the alignment (horizontal, vertical left, vertical right, diagonal, and curved layouts), and the spacing patterns (normal and divided patterns). The task performance or mean distance error is a dependent variable for hypothesis testing.

6.3.1 Task and procedure

In this test, the procedure was similar to Experiment 1, except for the presentation mode of the layout. In Figure 6.10, the fifteen layouts were presented one at a time. Participants were faced with a single layout, consisting of four positions for button layouts and three or four lines for line drawing layouts. They were required to proportionally map the button position of the imaginary interface to the touch position on their mobile. As the participants focused on one layout, the memory load was lower than in Experiment 1.

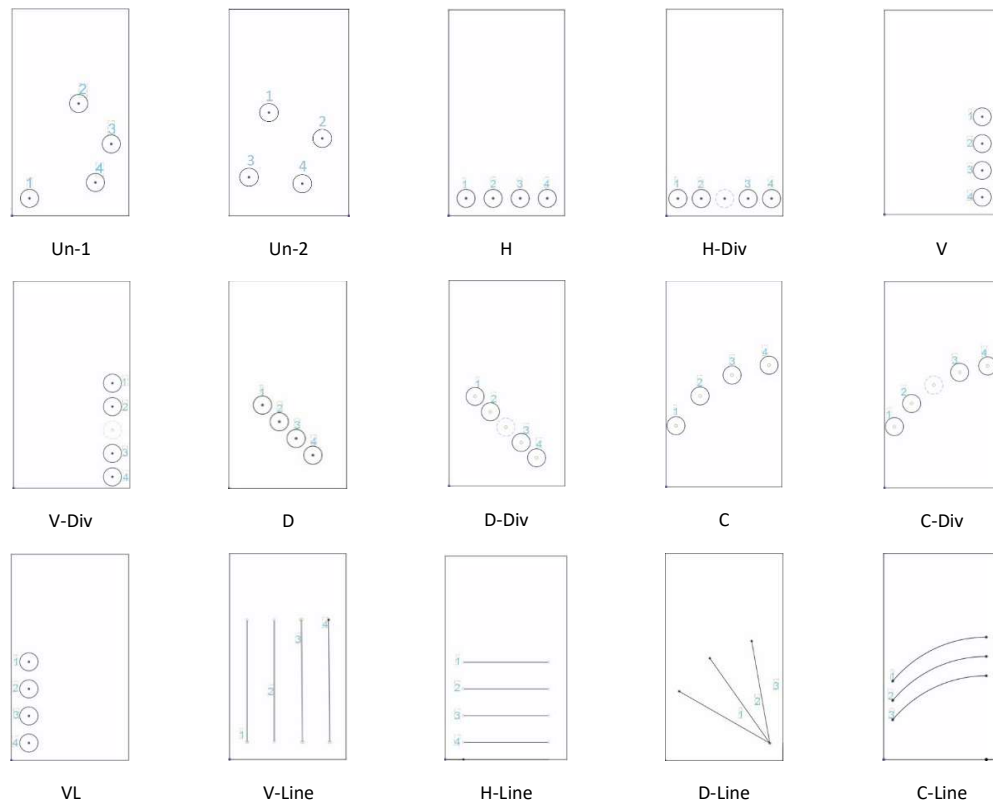

Figure 6.10 Interface layouts in Experiment 2

Participants must map positions on the spatial layout to interact on a touchscreen accurately as possible. During the test, sets of the button/line names were spoken one set at a time while the participants needed to respond to this audio stimulus from their mobiles by tapping or drawing on the mobile screen. When the tests had finished, the participants were asked to rank the layouts based on their easiness levels without knowing about their performance accuracy.

6.3.2 Hypotheses

Four hypotheses were formulated in this experiment as follows:

H5: The alignment of the layout impacts eyes-free performance. Therefore, the structure button layouts are expected to provide a significant difference in performance accuracy.

H6: As the positions near the anchor point and reference frame offer good proprioceptive accuracy, Button 4 of structure layouts is expected to provide better task performance than others that have a long distance from the anchor point and reference frame.

H7: As the line drawing layout and the button (tapping) layout require different interaction techniques, those layouts which have matched spatial positions are expected to provide a significant difference in performance accuracy.

H8: The divided pattern provides a middle anchor position for useful clues. Thus, the divided pattern layouts are expected to provide a different performance accuracy from the normal layouts.

6.3.3 Results

The following sections present the results of the experiments consisting of outcome pattern and task performance, as well as the rating scales of participants on easiness of interface layouts.

6.3.3.1 Outcomes and task performance analysis

There are 3,828 data points collected from 22 participants x 11 button layouts x 12 sequences of audio stimulus, plus 22 participants x 2 drawing layouts x 12 sequences of audio stimulus, plus 22 participants x 2 drawing layouts x 9 sequences of audio stimulus. The distance errors for all layouts are included in Appendix 7. The researcher removed 46 outliers (1.20%) and 1 error trial (0.03%), leaving 3,781 data points in this analysis. The data were processed and then the normality was analysed before doing the inferential statistical procedures. It was found that all data have skewness less than 2.0 and kurtosis less than 7.0; therefore, response data has a normal distribution. The experimental outcomes were shown in Figure 6.11 for the line drawing task.

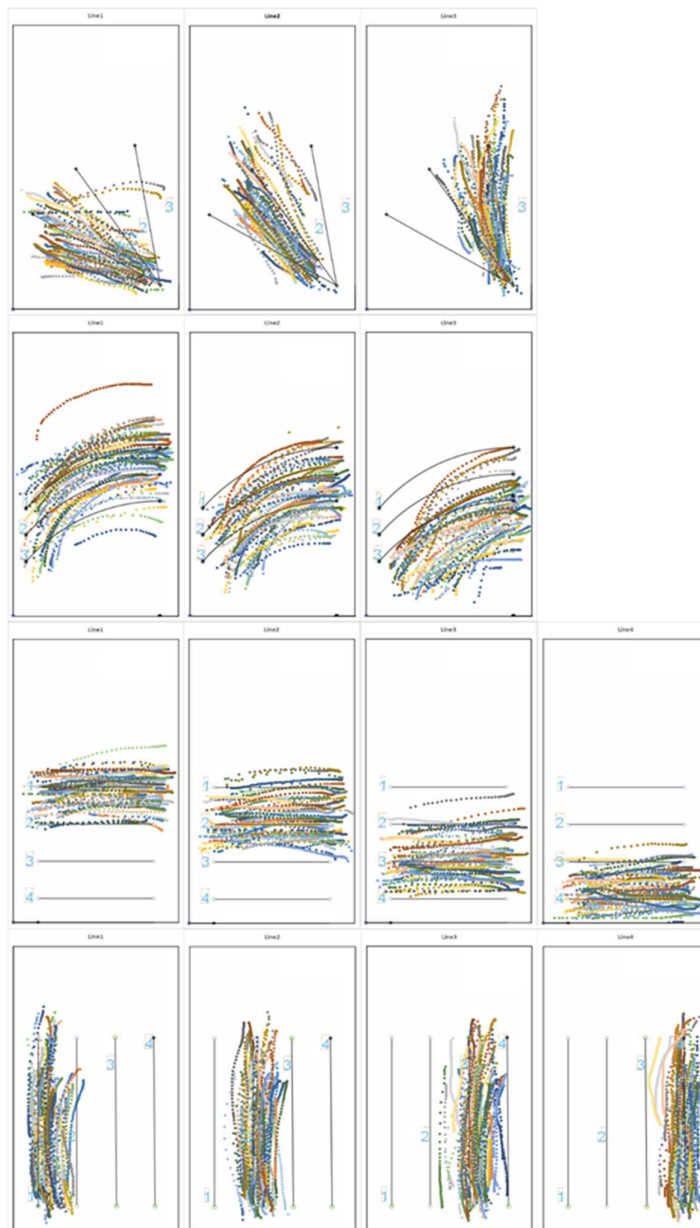

Figure 6.11 Line drawing outcomes in Experiment 2

Much information is also gained from this test such as the direction of movement, consistency, and line length. It was found that most of the participants drew a diagonal line outward from the common point and drew upward for a vertical line layout while they swiped the horizontal lines and curved lines from left to right. The characteristics of lines are noticeably varied, which seem to depend on the drawing method. The outliers on the diagonal layout were found on the lines drawn from outside toward the common point while the outliers on the vertical layout were found on the lines drawn in a downward direction. The steady outcomes occur in the lines drawn outward from the base. This means that drawing starting from the common

(anchor) point or the handgrip position could probably be better for proprioception. Moreover, the line length varied among the participants. The horizontal lines seemed parallel with the screen frame orderly. The drawing outcomes on the C-Line layout looked like parabolic curves according to the thumb functional area model (Bergström-Lehtovirta and Oulasvirta, 2014). It was found that the curve layouts, whose outcomes required swiping radially, relied heavily on physical human factors, bringing about a high outlier.

The outcome trend and precision of line drawing layouts were analysed in Table 6.5. The interquartile range indicates the precision of how spread out the entirety of the data set is. As the target coordinate was subtracted from the median of the actual touch coordinate, the positive sign of the trend specifies that the actual touch position was located on the right or upper side of the target level. It was found that the V-Line layout that requires space discrimination akin to the horizontal button layout provides the lowest spread range. The lowest interquartile range was Line 4 (7.06) whose position was closest to both the anchor point and the screen reference frame, followed by Line 1 (7.72) whose position was close to the screen reference frame. On the other hand, the H-Line layout required space discrimination akin to the vertical button layout. It was found that Line 1 and Line 4 of the H-Line layout provided a narrower interquartile range than other lines. In other words, the lines drawn in the inner area had a wider range as opposed to those on the outside that were close to the screen frame. Moreover, Line 2 of the D-Line layout was found to have the lowest angle range (11°). Interestingly enough, the diagonal button layouts seem to fit within the range of Line 2 of the D-Line layout.

The participants predominantly positioned the vertical lines on the right side of the target except for Line 4 in the rightmost position which tended to be put to the left of the target. They tended to draw a horizontal line above the target, except for Line 1, whereas all levels of the C-Line layout tended to be put below the target. Finally, the angles on the D-Line layout tended to be shifted down for Line 1 and 2, but shifted up in Line 3.

Table 6.5 The outcome trend and interquartile range of line drawing layouts

| Layout | Line 1 | | Line 2 | | Line 3 | | Line 4 | |
|--------|--------|-------|--------|-------|--------|-------|--------|-------|
| | Trend | Range | Trend | Range | Trend | Range | Trend | Range |
| V-Line | + | 7.72 | + | 9.23 | + | 8.57 | - | 7.06 |
| H-Line | - | 12.46 | + | 17.68 | + | 18.17 | + | 12.56 |
| D-Line | - | 15.3° | - | 11° | + | 18° | | |
| C-Line | - | 16.84 | - | 13.14 | - | 17.34 | | |

Note: + = actual touch located above or right of the target value, - = actual touch located below or left of the target value

Task performance of line drawing layouts is presented in Table 6.6. The mean error was minimum for the V-Line layout (5.48), followed by the H-Line (8.22), D-Line (9.60), and C-Line (10.10) layouts. Then, the repeated measures ANOVA was performed to investigate the difference in the mean error among lines for each layout. There was a significant effect on the mean error of lines for the V-Line layout ($F_{3,21}=3.46$, $p=0.02$) and the D-Line layout ($F_{2,21}=9.36$, $p=0.00$). Line 4 on the V-Line layout (3.99) and Line 2 on the D-Line layout (7.32) provided the lowest mean error. However, the ANOVA did not show a significant effect on the mean error of lines for the H-Line layout and the C-Line layout ($p>0.05$). In other words, the performance accuracy for each line was quite similar.

Table 6.6 Mean errors in line drawing.

| | V-Line* | H-Line | C-Line | D-Line* |
|---------|--------------------|------------|-------------|--------------------|
| Overall | 5.48 (2.3) | 8.22 (4.2) | 10.10 (5.1) | 9.60 (3.4) |
| Line 1 | 6.26 ^a | 6.95 | 9.77 | 12.79 ^a |
| Line 2 | 5.30 ^{ab} | 8.83 | 10.02 | 7.32 ^b |
| Line 3 | 6.36 ^a | 8.80 | 10.50 | 8.68 ^b |
| Line 4 | 3.99 ^b | 8.29 | | |

Note: Values shown for the D-Line layout are in degree. * implies the layout whose line position has a significant effect on the mean error. The values with significant differences ($p<0.05$) are indicated by different letters.

Figure 6.12 shows the experimental outcomes for tapping tasks. Touch positions for Button 1 to 4 are presented in blue, red, grey, and yellow, respectively. It was found that the unstructured layouts had highly dispersed outcomes. The straight alignment layouts provided narrow strip outcomes as opposed to the curved layouts. Task performance of the unstructured layouts is

presented in Table 6.7. The repeated measures ANOVA result did not show a significant main effect of button position on the mean distance error of the Un-1 ($F_{3,21}=1.25, p=0.30$) and Un-2 ($F_{3,21}=1.25, p=0.30$). The overall mean distance error and standard deviation for the unstructured layouts in a unified frame presentation was 12.81 and 2.87.

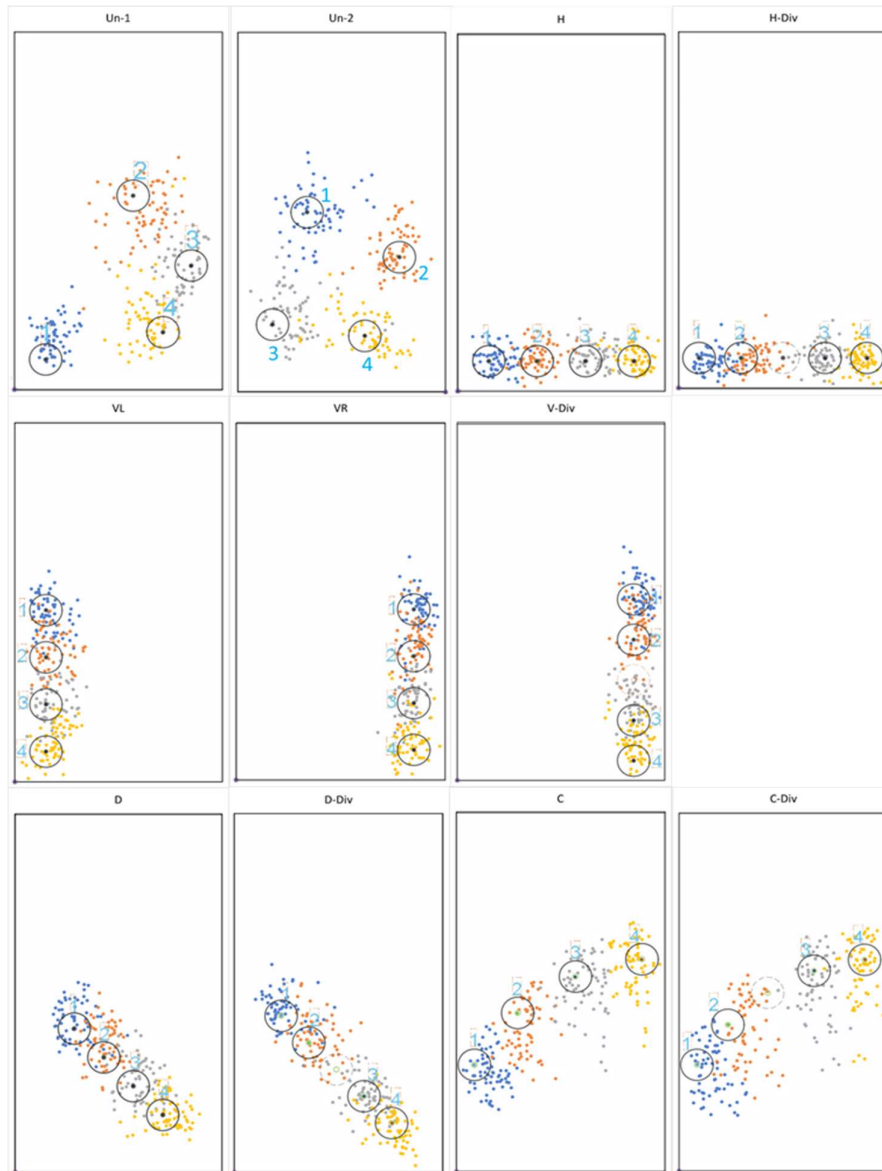

Figure 6.12 Outcomes on button layouts in Experiment 2

The fourth hypothesis formulated in the previous section that the performances of the unstructured patterns in the simultaneous presentation mode or a unified layout were expected to be better than those in the sequential presentation mode can be proved from this result. The results of the Un-1 and Un-2 layouts in Experiment 1 whose buttons were presented in separate

frames revealed higher values on both the mean distance error (17.09) and the standard deviation (5.86). The paired samples t-test was performed on the mean distance error of the Un-1 and Un-2 layouts between the two experiments that had a different mode of presentation ($t_{21}=3.05$, $p=0.00$). The result revealed that the mean distance error for the unstructured layouts in Experiment 2 was substantially lower than that in Experiment 1 (serial presentation). In other words, the performance accuracy of unstructured layouts was improved with the simultaneous mode of presentation. Thus, the result supported H4 that simultaneous presentation was more advantageous to spatial memory than serial presentation.

Table 6.7 Mean distance error (units) of the unstructured layouts in a unified layout or simultaneous presentation mode

| | Un-1 | Un-2 | All layouts |
|------------|--------------|--------------|--------------|
| Overall | 13.43 (3.86) | 12.19 (3.18) | 12.81 (2.87) |
| Position 1 | 12.19 | 12.65 | |
| Position 2 | 15.07 | 10.43 | |
| Position 3 | 12.70 | 13.66 | |
| Position 4 | 13.84 | 12.10 | |

Note: SD is shown in brackets.

Task performance of the structured layouts on the normal layouts and divided pattern layouts is presented in Table 6.8 and Table 6.9. The repeated measures ANOVA showed a significant main effect of the mean distance error on alignments in the normal layouts ($F_{4,21}=5.53$, $p=0.00$) and in the divided pattern layouts ($F_{3,21}=9.95$, $p=0.00$). Figure 6.13 provides grouping information among layouts. Data that do not share the same letter are significantly different. It was found that the horizontal, vertical, diagonal, and curved layouts reveal a significant difference in the mean distance error. Thus, H5 that the button layouts that are in different alignments provide a significant difference in performance accuracy is confirmed. For the normal layouts, the mean distance error was minimum on the H layout (7.60), followed by the VR, VL, D, and C layouts. However, performance accuracy on the VR and VL layouts was not significantly different. This might be because both layouts had the same alignment and vertical symmetry. For the divided pattern layouts, the mean distance error was minimum on the H-Div layout (7.56), followed by the D-Div, V-Div, and C-Div layouts. It is interesting to note that the performance accuracy of the D-Div layout was the second rank, instead of the V-Div layout.

Table 6.8 Mean distance error (units) of the normal layouts in Experiment 2

| | H | VR | VL | D | C* |
|----------|------------|------------|------------|-------------|---------------------|
| Overall | 7.60 (2.7) | 9.16 (3.9) | 9.46 (2.9) | 10.35 (3.0) | 11.88 (4.3) |
| Button 1 | 7.60 | 8.24 | 8.96 | 10.26 | 11.31 ^{bc} |
| Button 2 | 7.44 | 10.13 | 10.27 | 10.74 | 13.32 ^a |
| Button 3 | 8.39 | 9.37 | 9.24 | 11.29 | 12.31 ^{ab} |
| Button 4 | 6.98 | 8.89 | 9.37 | 9.12 | 10.51 ^c |

Note: SD is shown in brackets. * implies the layout whose button position has a significant effect on the mean distance error. The values with significant differences ($p < 0.05$) are indicated by different letters.

Table 6.9 Mean distance error (units) of the divided pattern layouts in Experiment 2

| | H-Div* | D-Div | V-Div | C-Div* |
|----------|-------------------|------------|------------|--------------------|
| Overall | 7.56 (2.7) | 9.60 (2.7) | 9.94 (3.7) | 13.41 (5.8) |
| Button 1 | 8.80 ^a | 9.63 | 8.84 | 13.03 ^b |
| Button 2 | 8.89 ^a | 10.97 | 10.13 | 16.39 ^a |
| Button 3 | 6.53 ^b | 8.83 | 10.50 | 13.00 ^b |
| Button 4 | 6.01 ^b | 8.98 | 10.30 | 10.98 ^b |

Note: SD is shown in brackets. * implies the layout whose button position has a significant effect on the mean distance error. The values with significant differences ($p < 0.05$) are indicated by different letters.

To investigate the effect of button positions, the repeated measures ANOVA was performed on the mean distance error among buttons for each layout. There was a significant main effect of the mean distance error for the H-Div layout ($F_{3,21}=5.71$, $p=0.00$), the C-layout ($F_{3,21}=4.27$, $p=0.00$), and the C-Div layout ($F_{3,21}=6.56$, $p=0.00$). Button 4 whose position is near the anchor point and reference frame provided more accuracy. However, the ANOVA did not show a significant effect on the mean distance error of button positions for the H, VL, VR, V-Div, D, and D-Div layouts ($p > 0.05$). The performance accuracy was not substantially different among the four buttons on these layouts. Therefore, H6 regarding the effect of button positions is only partially confirmed.

The H and V-Line layouts were discovered to require horizontal spatial discrimination at the same position. Likewise, the VL and VR layouts required vertical spatial discrimination at the same level as the H-Line layout. To investigate the effect of the interaction technique, the

paired samples t-test was performed on the mean distance error among these layouts. The mean distance error on the V-Line layout was substantially lower than the mean distance error on the H layout ($t_{21}=3.58, p=0.00$). However, no significant difference was found between the VL and H-Line layouts ($t_{21}=1.32, p=0.20$), and between the VR and H-Line layouts ($t_{21}=0.73, p=0.47$). Thus, H7 was only partially confirmed that the button layouts that were required tapping at matched spatial positions with the line drawing layout provided a difference in performance accuracy.

| Type | N | Mean | Grouping | |
|------|----|---------|----------|---|
| C | 22 | 11.8805 | A | |
| D | 22 | 10.3537 | A | B |
| VL | 22 | 9.4580 | B | C |
| VR | 22 | 9.1556 | B | C |
| H | 22 | 7.6030 | C | |

| Types | N | Mean | Grouping | |
|-------|----|---------|----------|---|
| C-Div | 22 | 13.4137 | A | |
| V-Div | 22 | 9.9433 | B | |
| D-Div | 22 | 9.6027 | B | C |
| H-Div | 22 | 7.5549 | C | |

Figure 6.13 Grouping Information among Layouts Using Fisher LSD Method and 95% Confidence

Looking at the effect of button proximity on each alignment closely, the researcher performed the paired samples t-test and saw that there is no significant difference between the H and H-Div layouts ($t_{21}=0.09, p=0.93$), between the VR and V-Div layouts ($t_{21}=0.71, p=0.48$), between the D and D-Div layouts ($t_{21}=1.14, p=0.27$), and between the C and C-Div layouts ($t_{21}=1.60, p=0.12$). Thus, H8 was not supported that task performance from divided pattern layouts is different from the normal layout.

6.3.3.2 Rating scales

Similar to Experiment 1, a few questions were posed regarding the participants' experiences with interface layouts. The research participants ranked the layouts from the easiest to the hardest for eyes-free interaction, based on their personal consideration and judgement. There is a small increase in the popularity of the divided pattern from 22.7% to 27.3%. The participants who like the divided pattern articulated their reason that this pattern could provide additional reference positions for segmentation. Obviously, the layouts in an equal distribution (72.7%) are preferred among most of the participants. Their feedback is portrayed in Fig. 6.14. For the normal layouts, the top score is the V layout, followed by the H layout, the C layout, and the D layout. However, the score is dramatically different between the VR layout (3.73) and the VL layout (2.18). Many participants claimed that buttons on the left side are hard to reach when using large mobiles. For the divided pattern layouts, the V-Div and H-Div layouts had the same preference level (2.82), being higher than the C-Div layout (2.73), while the D-Div layout (1.64) had the lowest score. It can be seen that the curved layouts were popular in the first selection of ranking order, but the overall preference score was on the V and H layouts.

The curved layouts are not restricted by the object frame and can be responded to quickly by lateral movement (egocentric approach), thus most of the participants prefer this kind of the layouts and vote on it to be the first rank without acknowledging the outcome in the mean distance error.

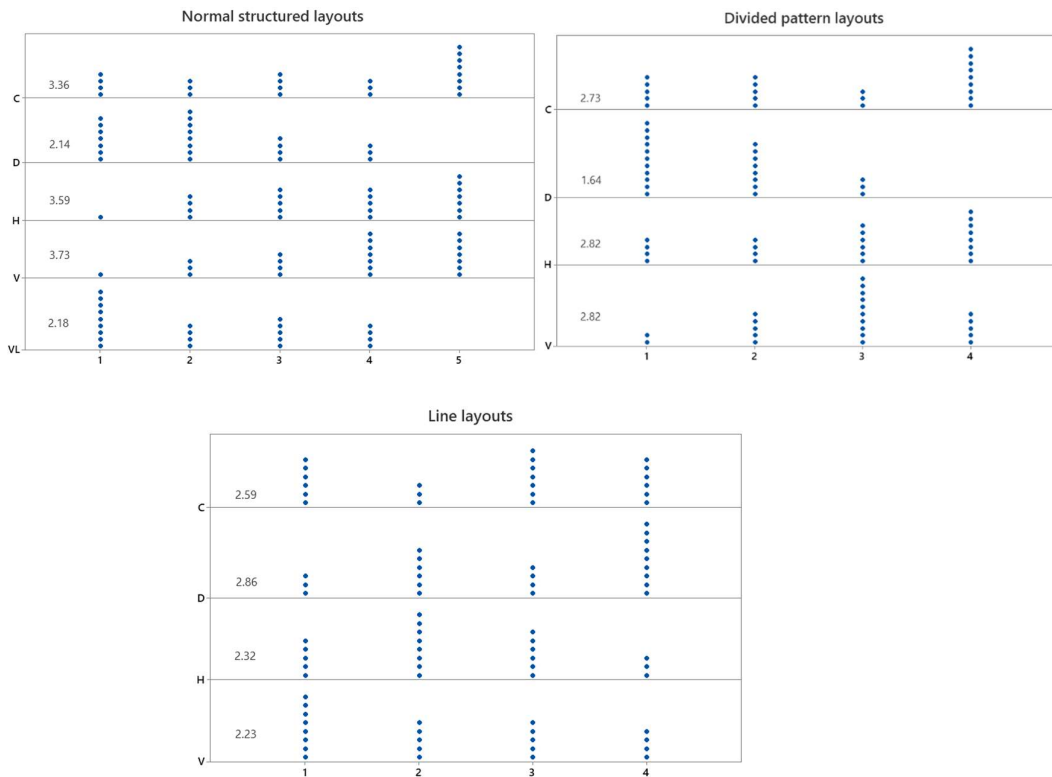

Figure 6.14 Preferred layout ranking

For the line drawing, they prefer drawing on the D-Line layout (2.86) most, followed by the C-line layout (2.59). Many research participants provided the reason that this pattern required a lower workload since they just oriented the yaw angle and then drew a line outward along this angle from the anchor position. Nonetheless, drawing vertical and horizontal lines requires a higher physical workload as the participants need to differentiate the line level and draw a line parallel to the screen. Thus, the preference for drawing this layout is quite low as opposed to the D-Line and C-Line layouts.

6.4 Discussion

6.4.1 Analysis of the results

The performance of response outcome could demonstrate the effect of interface configuration in eyes-free touchscreen interaction caused by spatial memory and resulted in proprioception. In this study, the visual interfaces were presented indirectly on the desktop display for

participants to memorise before performing eyes-free interactions on the touchscreen mobile. All the participants have to learn and build a mental map of the identical eyes-free interface, and transfer or translate their spatial knowledge to deliberately tap at targets on their unseen touchscreen. All targets were presented within a frame similar to the touchscreen frame for reference. The results of the experiment showed that the participants were able to learn positions and spatial relations among buttons within a reference frame and to interact on a touchscreen with their short-term memory. They had limited time to construct mental imagery of spatial interface but could use this spatial understanding to map the position accurately.

There were obviously different results between Experiment 1 (serial mode of presentation) and Experiment 2 (simultaneous mode of presentation). Being able to see the unified frame configuration, the participants performed the tapping task of unstructured layouts better in simultaneous presentation mode. The touch positions of the Un-1 and Un-2 layouts shown in Figure 6.12 are much more precise as opposed to those in Figure 6.8. Vandierendonck and Szmalec (2011) suggested that a simultaneous presentation led to better recall of spatial position. The results from this study were in line with their work. In other words, interface layouts presented locations in a single frame provided better performance accuracy than sequential or separate presentations. All targets should be presented within a unified reference frame.

The outcomes of the unstructured layouts showed better performance accuracy on the layouts whose sequence arrangement was logical. The layout which arranged button sequences in the same direction from left to right with either consistent or intermittent patterns had less mean distance error than the layout which had an intermittent sequence arranging from right to left. This supported the previous findings of Smirni et al (1983) that the choice of the paths should be familiar and logical.

As expected, performance accuracy was better for the structured layouts than the unstructured layouts. The structured pattern provided the salient feature of organisation and distance relation, it therefore enhanced spatial mapping process. Tversky (2002) claimed that mental load was decreased with schematisation because the relevant information was compressed and captured well. Thus, layouts with any nearby and related objects promoted the recall performance.

After the investigation of the line drawing task in Experiment 1 in which the participants were required to memorise the line pattern in addition to the spatial position among four layouts that competed for memory, obvious drawing mistakes were found occurring in all of the layouts. However, performance of the H-Line layout, presented in the final order, was still satisfying.

The outcomes of button layout also showed the superior quality of horizontal alignment on spatial memory. The participants interacted with positions from the horizontal layouts effectively. The results were in line with the findings in the previous research that the vision ability increased in the horizontal direction, or spatial memory was better for the patterns that were symmetrical along the vertical axis (van Beers et al., 2002; Cattaneo et al., 2008).

The alignment of the layout impacted eyes-free performance. The layouts in straight alignment provided better task performance than the curve alignment. The mean distance error was minimum on the horizontal layouts, followed by the VR, VL, and D-Div layouts. The curved layouts gave the poorest touch accuracy. It was found that button accuracy within the layout was similar, except for the H-Div, C, and C-Div layouts whose Button 4 gave better performance. Among the four buttons of the structure layouts, Button 4 has the shortest distance from the anchor point. Though Button 4 in the curve layout has been located at the same radius (same distance from the anchor point) as the other buttons, it is located on the right side, more close to the palm than the other buttons. That is the positions near the anchor point, close to the palm, and the reference frame provided tactile cues for effective orientation and offered good proprioceptive accuracy. Overall, the straight layouts with an equal button distribution made stable spatial discrimination performance.

Surprisingly, although the spaces between Button 1 and Button 2 and between Button 3 and Button 4 on the divided pattern layouts are smaller because of the existence of the middle reference button, performance accuracy on the divided pattern layout, containing five buttons is equivalent to performance on the normal four-buttons layout. It was supposed that the middle position was a useful clue for spatial discrimination. In other words, the divided pattern layouts containing five buttons could be provided useful clues from a middle anchor position. Furthermore, it was found that the accuracy of buttons near the middle position on divided pattern layouts was obviously improved when tested on each button among four layouts in Experiment 1. Therefore, middle segmentation strengthened spatial recognition and task performance.

Drawing a line seemed to provide better performance accuracy than the button layout as it offered navigation and adjustment during the drawing process. It was found that the V-Line layout with the same spatial discrimination as the H layout offered a lower mean distance error. However, there was a significant difference in performance accuracy between the vertical lines while there was no significant difference in performance accuracy between buttons in the H layout. In addition, drawing a line required a higher physical workload and completion time.

For these reasons, adopting a drawing layout was suggested only when it was related to an additional interaction vocabulary/technique.

Post-test feedback from the participants on the interface preference was useful for interpreting the results. The participants preferred the normal layouts whose buttons are evenly spaced consistently rather than the divided pattern layouts. Most participants agreed that the horizontal button and the horizontal line layouts were the easiest patterns to remember. Moreover, they preferred the vertical layout on the right and the D-Line layout. The possible reason might be that these layouts required the natural thumb posture orientation from the common anchor point, close to the palm.

All findings of the present study improved understanding of innate human ability and insight for designing an effective eyes-free interface. The interface characteristics would be investigated further in the next section in order to propose the optimal interface design enhancing performance accuracy caused by spatial memory and proprioception.

6.4.2 Analysis of the interface configurations

For the single-handed thumb interaction, the research participants used their thumb in a complex combination of linear and angular motion components in a 3D anatomical reference system. Therefore, it can be seen that various thumb postures or gestures affect touch accuracy (Umami et al., 2016; Mayer et al., 2017). However, the finger gestures had been changed by the interface layouts. To gain an understanding of the layout design characteristics, each interface configuration was then investigated in detail regarding the dimensions and relations (Table 6.10 and Figure 6.15). Insights from this investigation could help to improve the effectiveness of interface design. The H and VR layouts are symmetrical along the diagonal axis shown in Figure 6.15 (a). This property could facilitate spatial perception and discrimination, resulting in better performance accuracy on the H, VR, and VL layouts. These layouts stay within a square of the screen width of 90 units. Figure 6.15 (b) shows the size of button spacing of the V-Div layout which is identical to the H-Div layout. As shown in Figure 6.15 (c), the diagonal line with length of 127.3, which is the most extended range from the reference edge, is the place that aligns the D and D-Div layouts. The button spacing size of the D and D-Div layouts is presented in Figure 6.15 (d) and (e). Finally, the curvilinear distance and the angular spacing of the button in the C and C-Div layouts are shown in Figure 6.15 (f), (g), and (h), respectively.

Table 6.10 Characteristics of each layout

| | Layout range | Normal layout | | Divided pattern layout | | Button (B) closed to reference frame | | |
|----|--------------|----------------|-------|------------------------|-------|--------------------------------------|----------------|----------------|
| | | Button spacing | d | Button spacing | d | bottom edge | left edge | right edge |
| H | 90 | 21 | 7.60 | 18.1 | 7.56 | B1, B2, B3, B4 | B1 | B4 |
| VR | 90 | 21 | 9.16 | 18.1 | 9.94 | B4 | - | B1, B2, B3, B4 |
| VL | 90 | 21 | 9.46 | - | - | B4 | B1, B2, B3, B4 | - |
| D | 127.3 | 18.18 | 10.35 | 16.89 | 9.60 | - | - | - |
| C | 118.27 | 29.83 or 18° | 11.88 | 22.37 or 13.5° | 13.41 | - | B1 | B4 |

d refers to a mean distance error. Values in the table are presented in relative units.

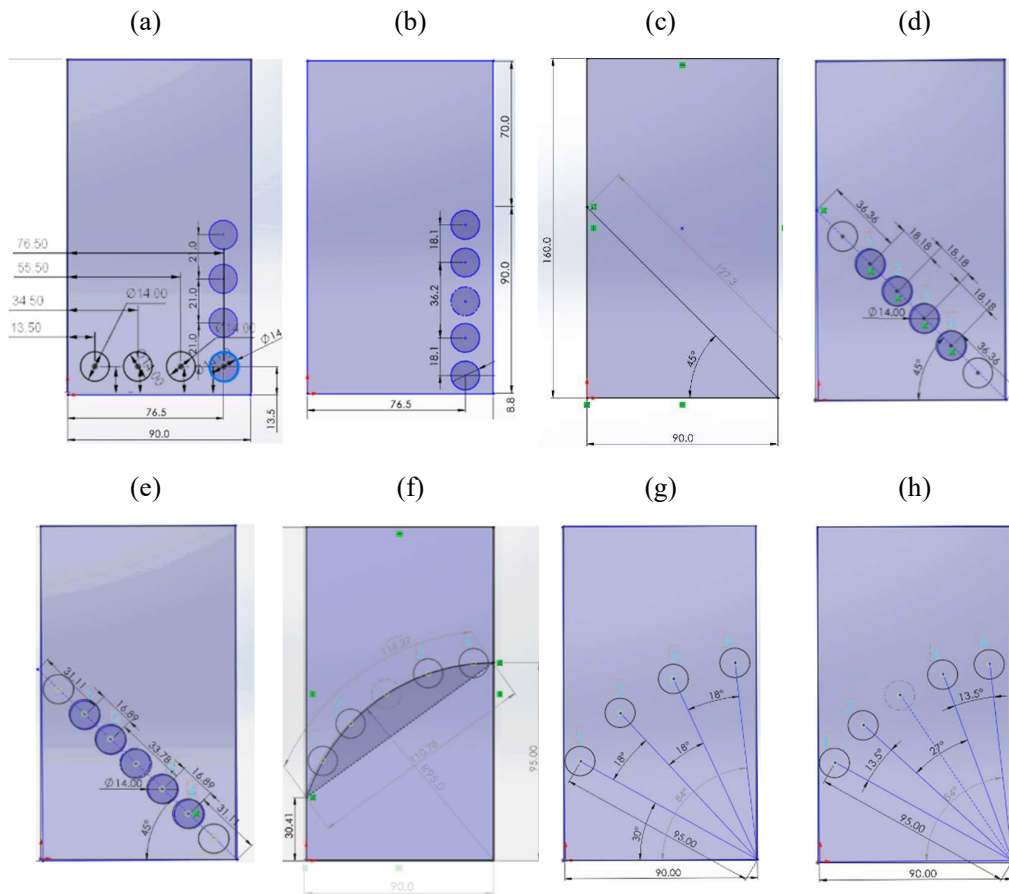

Figure 6.15 Layout dimensions and relations

The performance on the horizontal layouts was significantly better than the other layouts. One possible reason might be the vertical symmetrical feature (Cattaneo et al., 2010). The buttons in the layouts are straight aligned in the narrowest segment of the screen. Moreover, the three device reference frames, i.e., the left, right, and bottom edges, are closer to the buttons than in

the other layouts (Table 6.10). Thus, the horizontal layouts exploit the highest level of the reference frame. The closer the reference point is to the targets, the more accurate the outcome. This finding conforms to the study of Lin et al. (2014) suggesting the strong spatial cues on the edge. Another reason might be that the visual sense of the target is in a wide view, because people usually scan the horizon for identifying spatial positions. According to these reasons, the horizontal layout is perceived, maintained, and retrieved better than other patterns. Though the H and H-Div layouts have similar mean distance error, performance accuracy between buttons in the H-Div layout was remarkably different. Button 1 of the H-Div layout is farther from the right edge than in the H layout, so its distance has increased from the anchor point. As a result, B1 in the H-Div layout cannot be easily reached and brings about poorer performance accuracy though it is close to the left edge. From the interviews, many research participants set their thumb in parallel to the bottom edge when interacting with these layouts. Under this approach, the thumb posture is stable (the fixed yaw and roll angles) and solely the pitch angle is varied to respond to any buttons. This suggests that movement in the in-depth direction or along the thumb flexion direction provides effective proprioception.

It was found that the preference rank on the horizontal layouts was lower than the vertical layout on the right even though the space between the buttons of the horizontal layout is similar to the vertical layout. This could be presumed that Button 1 of the horizontal layouts was on the left side, far from the palm.

For the vertical layouts, only two edges (the bottom edge and one-sided edge) are close to buttons. Button 1 is far and floated from the upper edge. Thus, the vertical layouts partially exploited the reference frame as opposed to the horizontal layouts. Mayer et al. (2019) suggested that the sweet area is in the lower right of the screen. Thus, it can see that the preference score on the VR layout is higher than the VL layout. With a large mobile phone, the users could not reach the left edge unless making a large grip shift. However, the performance accuracy for the VL layout was slightly lower than for the VR layout. In addition, it was found that Button 3 and Button 4 in the V-Div layout have higher mean distance errors than those in the V layout. These imply that the position in the vertical right should not be too low (too close to the anchor point) making the contact point imprecise. The research participants require a greater pitch angle and roll angle to interact on a bottom right button. The lower right and upper left locations are difficult to reach for a right thumb interaction (Boring et al., 2012). Le et al. (2018) suggested putting interface controls within the comfortable area. Indeed, the comfortable area also contributes to tapping accuracy other than the closeness to reference frames.

The D and D-Div layouts have buttons at a central part diagonally aligned at 45° from the bottom right corner. Although buttons in the diagonal layouts seem to be far from the side edge, they have a constant relation to the reference frames. Figure 6.15 (d) and (e) show two hidden buttons at the edge of the D and D-Div layouts. These buttons have the same spacing as the other buttons within the layout. Despite the space between buttons being the shortest, the overall performance on the diagonal layouts is similar to the vertical layouts and better than the curved layouts. One possible reason might be because this layout offers a natural thumb stretch (comfortable gesture). The electrical signal in neurons is affected by stretching in receptors in joints (Groh, 2014). The body position sensing will be more effective if there is a stronger stretch. The researcher hypothesised that gestures in the in-depth direction and comfortable thumb posture (natural thumb position) might contribute to spatial acuity. In addition, it was found that Button 3 in the D-Div layout provides the lowest mean distance error instead of the edge buttons (Button 4 or Button 1) on other layouts. The possible cause might be that the research participants took advantage of a diagonal symmetrical axis for an additional reference point. Guided by the middle reference position, the participants could estimate the distance to an adjacent button better.

Interacting on the curved layout involves lateral motion and yaw angle variation from the MCP and RC joints (2 DoFs) while interacting on the horizontal, vertical, and diagonal layouts requires motion along the thumb flexion direction from the hinge joint (DIP) which is the end joint of the thumb (1 DoF). The lower the degree of freedom, the more the performance accuracy. In addition, spatial judgments on the C and C-Div layouts crucially depend on the level of the thumb along the curve axis. Only Button 1 and Button 4 are close to the side edge which could guide the proprioception. As the thumb length of participants varies, the outcome is less accurate and less precise (a wider spread). Interacting that relies on the body characteristics such as the thumb bending level and the thumb movement in the lateral direction deteriorates performance. As a result, the C and C-Div layouts provide the poorest touch accuracy, in spite of the space between buttons being the longest among all the layouts. Besides, it was found that the layout in the divided pattern makes the performance deteriorate. The researcher hypothesised that this is because the middle point of the C-Div layout is angled at 57° which seems not to cue intuitively for guiding the position. Other than having the highest mean distance error, the curved layouts have a significant difference in the mean distance error among the buttons. Thus, curved layouts are not suggested in designing the eyes-free interface.

The next section will summarise insight from the experimental findings suggesting a group of essential interface configuration characteristics to synergise the strengths of spatial memory and proprioception for non-visual touchscreen interaction.

6.5 Implications for design

In this study, the performance accuracy under various interface configurations has been tested and proved hypotheses. Based on the results from two experiments, the researcher discovered that eyes-free input accuracy depends on spatial memory of interface configuration and proprioception. Insight from the previous section brings about the development of the interface configuration design framework. The design framework of the eyes-free interface under a single-handed thumb posture is proposed in Figure 6.16. The design framework consists of seven pillars of interface configuration characteristics supporting non-visual touch screen interaction. The left four characteristics involve the interface presentation that would promote spatial recognition and memory while the right three characteristics involve the interface area that would support proprioception. To enable effective interaction in eyes-free mode, the interface should be configured in a structured pattern with evenly spaced buttons, presented in a unified frame, set with horizontal alignment, and allow middle segmentation. The interface elements should be positioned along the thumb flexion direction, in the area that provides symmetry in a square, and in proximity to the device frame within a comfortable thumb range. These answered the RQ3 about the characteristics of interface configurations providing advanced performance accuracy. When developing an eyes-free touchscreen interface, designers should consider the following processes.

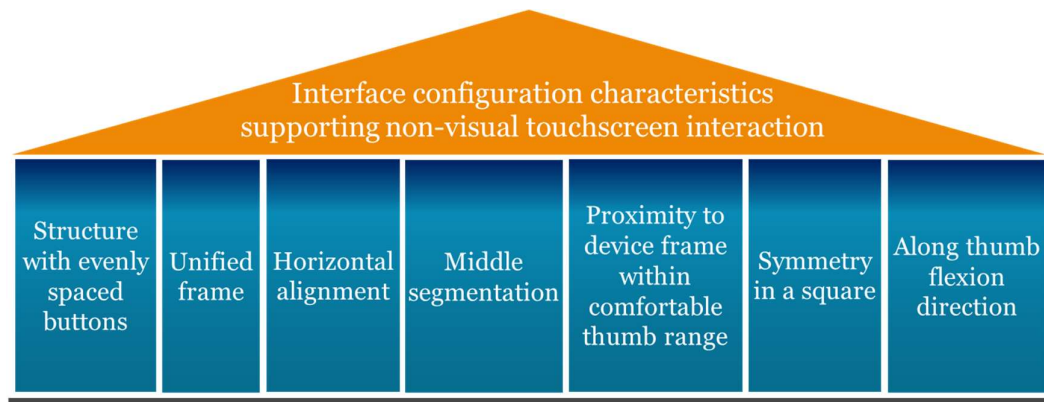

Figure 6.16 Design framework of eyes-free interface

1. Structure with evenly spaced buttons: Design the structured patterns that align each button with even spacing. The structured layout provides redundant spatial cues, continuation, and regularity. Putting buttons into a straight line with an equal

distribution pattern forms the effective structure layout, facilitating the spatial discrimination process for non-visual touch screen interaction.

2. Unified frame: Put interface elements united in a single frame. Users tend to describe the relation of an object with respect to another object and a reference frame. Presentation of the related objects in a single frame facilitates perception. Users can integrate various spatial objects through the same view and frame of reference under the schema. Therefore, the mental image of an interface can be constructed effectively for eyes-free interaction.
3. Horizontal alignment: Let the horizontal alignment be the first priority when designing eyes-free interfaces. This alignment provides better spatial memory because the person's field of vision scans horizontally. Moreover, the horizontal alignment has a vertical symmetry and fully exploits the physical features of the device (the bottom base, the left and right sides of the screen). Thus, spatial discrimination on the horizontal layout provides good performance accuracy.
4. Middle segmentation: Using the middle button or the halfway location in equal proportion for a reference to other buttons in the layout could facilitate the spatial discrimination process. Though the decision between the use of an odd/even number of buttons depends on the interaction area and a compromise between target size and spacing size, the number of targets for the odd numbers would be beneficial as the middle button from the odd button series could be used as an additional anchor point. Using the middle segmentation for a reference reduces the workload in eyes-free interaction. Thus, if applicable, middle segmentation would be suggested.
5. Proximity to device frame within comfortable thumb range: Design the layouts that fully exploit the physical features of the device (edge, side, corner) because these features are stable, easily distinguished, and universal among users. The frame of reference is the vital cue to spatial memory and proprioception. The relative distances between objects in a fixed frame are logically and proportionally coded in a mental map. The greater the number of reference frames on the layout, the greater the precision. The more closely the button is aligned to the reference frame, the greater the performance accuracy. In addition, it is essential to put the interface in the comfortable thumb area because uncomfortable gestures reduce performance accuracy. Positions that are out of reach or too low require additional supportive micro-movements. The interface area should not exceed the thumb length and the comfort or natural thumb position.

6. Symmetry in a square: Adopt the square area to configure the interface as the square offers the most lines of symmetry. Symmetry quality facilitates spatial memory in human visual perception. The horizontal, vertical, and diagonal layouts constitute the grid square symmetry. The vertical buttons that are put in identical spacing sizes with the horizontal alignment strengthen spatial memory and muscle memory. The diagonal alignment from the bottom right corner could exploit the detection of diagonal symmetry and give a suggestion to the middle position of layouts, used as the virtual reference axis for the spatial discrimination process. These simple and familiar relationships enhance human cognition, resulting in better proprioception.
7. Along thumb flexion direction: Design the layouts such that they tighten the degree of thumb movement. Buttons in the area along the thumb axis can be more easily discriminated against under the hinge of the thumb. If the posture is stable and certain, spatial acuity will be improved properly. The distance discrimination from the hinge joint (flexion) gives a strong spatial precision as opposed to the angular discrimination from the knuckle joint. Thus, motion along the thumb flexion direction provides a better touch accuracy than lateral motion. The horizontal, vertical, and diagonal layouts from the bottom right corner in a square grid area are examples of one-dimensional alignment in the thumb flexion direction.

6.6 Summary

This chapter consists of two experiments to examine the role of interface configuration so as to deepen understanding of spatial memory and proprioception. The serial presentation of the four-framed layouts was adopted in Experiment 1 to test the participants on which layout or target position could be stored and retrieved spatial positions better, whereas the single layout presentation was applied to Experiment 2 in order to test the performance accuracy for each layout directly. The analysis performs on the outcome and task performance, hypothesis testing, and post-test feedback from the participants. The discussion was highlighted on characteristics of interface configurations and performance accuracy so as to answer the research question (RQ3). Finally, the conceptual framework for designing an eyes-free interface was proposed.

Chapter 7 Design guideline development and validation of eyes-free interface design

Chapter 6 provided insights on spatial memory and proprioception, as well as the design framework, established for supporting effective eyes-free interface configuration of touchscreen interfaces. In this chapter, the design guidelines are then developed to guide user interface designers to configure the eyes-free interface step by step in the form of a process flowchart. Beyond the design framework, the design process flowchart is a useful tool in presenting a prescriptive method supporting the practitioner to configure the eyes-free interfaces to attain high accuracy and efficiency.

In the validation stage, the prototypes of eyes-free interfaces for applications on a touchscreen were designed and adopted for the user study evaluation. In addition, expert interviews were associated to review the practicality of the theoretical framework and process flowchart for designers. Ultimately, the comments derived from interviewing with the experienced user interface designers and the findings from the usability test were proposed to assess the suitability of the design framework and the developed design guidelines.

This chapter delivers 1) the design guidelines providing the practitioner the information about the configuration steps of an eyes-free interface, 2) the implementation of design guidelines for designing applications on a touchscreen, and 3) the validation of the design framework and guidelines for eyes-free interface configuration of touchscreen interfaces which were proceeded through the experiment and the interviews of the experienced user interface designers.

7.1 Development of design guidelines

This section will develop interface design practices for the control interface in mobile interaction in eyes-free mode for right-handed users. Implications regarding the design referenced in the previous chapter provided the design framework consisting of characteristics of interface supporting non-visual touch screen interaction. These interface characteristics strengthen spatial memory and proprioception, resulting in better performance accuracy in touchscreen eyes-free interaction. To apply a touchscreen input for eyes-free interaction, the design guidelines (flowchart) for mobile application interfaces are developed in order to provide the practitioner the information step-by-step about the processing steps in configuring an eyes-free interface. Each stage in the process of the flowchart is also explained to gain an understanding of eyes-free interface characteristics related to the design framework.

As the interaction area should be restricted to the comfortable thumb range and human mental resources are limited, the number of interface elements adopted in this flowchart should not exceed fifteen items. This eyes-free interface would serve as a shortcut menu for dexterous operation. The process of eyes-free interface designing was composed of three layouts, namely the reversed L-shaped layout, the U-shaped layout, and the underlined N-shaped layout. The process flowchart shows visual clarity of the instructions step by step, providing instant and effective communication in designing eyes-free interface layouts.

The findings on the role of Interface configuration for eyes-free interaction reveal that the horizontal alignment (the H layout) provides the best performance accuracy, followed by the vertical right (the VR layout), vertical left (the VL layout), and diagonal in divided pattern (the D-Div layout). These layouts provide good performance accuracy under the right-handed thumb interaction. As mentioned earlier, the interface design could adapt and integrate these layouts together, depending on the number of elements needed in each application. Thus, these alignments would be combined into different shaped layouts for mobile application interfaces.

1. The reversed L-shaped layout

The reversed L-shaped layout is constructed from a combination of the horizontal and vertical right layouts. Thus, this layout could be suited for a shortcut menu with the number of interface elements not exceeding seven, resulting from four buttons in each direction with one common point at the lower right corner. The developed framework has guided the design process to structure the unified layouts with evenly spaced buttons, and adopt the horizontal alignment in the first place under the square area and put buttons close to the device frame within a comfortable thumb range. Thus, the first step in the flowchart suggests setting the interface area in the square area at the lower part of the screen since the user's grip position and thumb knuckle are usually at the lower part. This square area relates to the screen width and the equal horizontal and vertical ranges of thumb stretch. Then, the horizontal alignment of the first four buttons is suggested to be put with even spacing at the bottom which is the level of the anchor point or handgrip. This causes the structured layout in relation to the left, right, and base sides of the device reference frame. Next, the button alignment is suggested to put the rest items vertically above the rightmost button of the horizontal layout. The bottom right corner of the screen on which the thumb knuckle is placed, is the anchor of the proprioception. This alignment could support motion along the thumb flexion direction that parallels the screen frame. As the previous experimental results showed that the vertical alignment gave a higher mean distance error than the horizontal alignment, it is suggested to provide more vertical spacing than the horizontal spacing slightly. This would fit with the concept of the functional thumb area represented by the parabolic curve (Bergström-Lehtovirta and Oulasvirta, 2014).

Furthermore, the buttons should have equal distribution. The consistent and straight aligned structure in the reachable area would be beneficial for spatial memory, muscle memory, and proprioception. Figure 7.1 provides the process flowchart for constructing the reversed L-shaped layout.

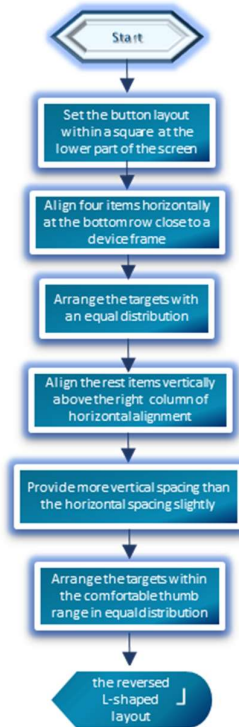

Figure 7.1 The process flowchart of constructing the reversed L-shaped layout

2. The U-shaped layout

The U-shaped layout is developed from the reversed L-shaped layout. In other words, this layout is constructed from a combination of the H, VR, and VL layouts. Thus, it could provide the maximum number of ten buttons, resulting from four buttons in each direction with the common points at the lower left and right corners. The first five steps would be identical to those in constructing the reversed L-shaped layout. Then the following steps involve adding the rest items vertically above the left column of horizontal alignment and setting the same height level of the buttons between the left and right columns. As a result, the layout would come in the U shape. This alignment could support vertical symmetry perception due to an equal distribution pattern and aid navigation along both sides of the screen frame. Therefore, the U-shaped layout contributes to enhancing spatial memory and proprioception. The process flowchart of constructing the U-shaped layout is shown in Figure 7.2. The blue boxes involve

the process steps in constructing the reversed L-shaped layout and the dark grey boxes are the further steps for constructing the U shape.

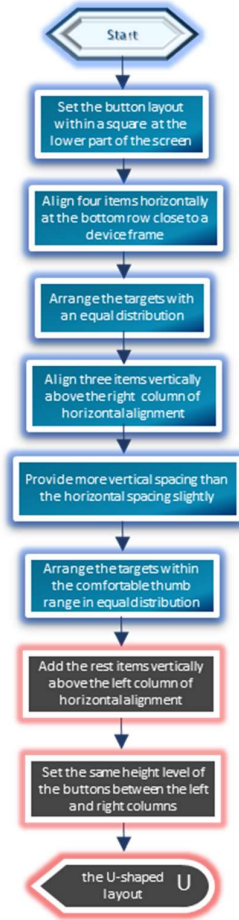

Figure 7.2 The process flowchart of constructing the U-shaped layout

3. The underlined N-shaped layout

This layout is further developed from the ten buttons layout in the U shape. The combination of the H, VR, VL and D-Div layouts in the previous study provides the underlined N shape. These four layouts provide good performance accuracy under the right-handed thumb interaction. This configuration leads to fully exploiting the functional interface area. Since the diagonal is the longest line in the square area and the previous outcome has shown a positive effect under the divided pattern (the D-Div layout), a maximum number of five buttons would be applied on the diagonal alignment. The maximum number of interface elements could be fifteen for this layout. Furthermore, all the elements relate to distance from the same anchor point at the lower right corner or the position of the thumb knuckle.

Figure 7.3 provides the process flowchart of constructing the underlined N-shaped layout. Similar to the previous development process, the underlined N shaped layout consists of the first seven steps identical to the steps in constructing the U-shaped layout. The next processes involve forming the diagonal button alignment for the rest items from the bottom right corner to the top left of the square area passing across the U-shaped layout. Then, it had better put buttons with an equal distribution in a divided pattern from the centre of the diagonal line or the square centre. This applies the point symmetric property to facilitate spatial memory and proprioception. The number of buttons can be 5 items or less. The red boxes in Figure 7.3 show these additional steps.

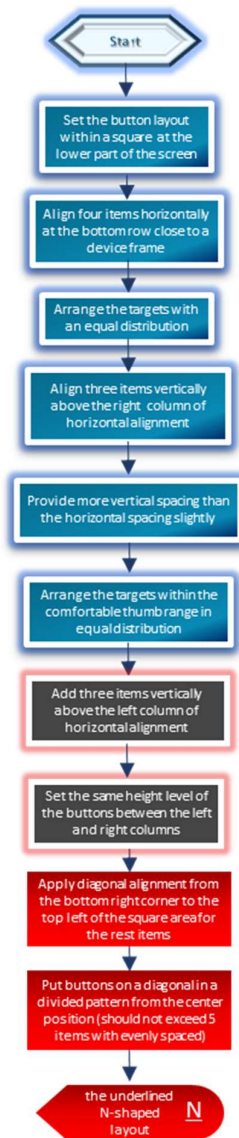

Figure 7.3 The process flowchart of constructing the underlined N-shaped layout

7.2 Designing eyes-free interface prototypes

This section applies the fundamental principles in the framework and the route to implementation in the guidelines for effective interface configurations in touchscreen eyes-free interaction. These design practices are utilised to design input interfaces for operating mobile applications for non-visual touchscreen interaction. To design the application interface configurations for one-handed thumb interaction, the overall process flowchart was developed and provided in Figure 7.4.

The process starts with considering the design requirements such as the number of interface items, the relation among items, and the pattern of usage or frequency-of-use/importance. Next, the decision process is required about the number of items that relate to configuring the particular layout. If the number of items is less than or equal to seven, the interface configuration will be the reversed L-shaped layout. If the number of items is more than ten, the interface configuration can be either the U-shaped layout or the underlined N-shaped layout, depending on the relationships among items. If interface elements are mutual dependence, they should be put all together in a single display under the underlined N-shaped layout. On the other hand, if the menus are not necessary to used together, the process could involve configuring the U-shaped layout that requires subdividing all items into several pages with ten items at most per page. Then, the process follows the process flowchart of constructing the reversed L-shaped layout, the U-shaped layout, or the underlined N-shaped layout as described in the previous section. The final step relates to assigning the functions to all buttons according to the pattern of usage, and assigning functions to buttons by putting frequently-used items at buttons close to the handgrip.

These design guidelines suggested the configuration order starting from the horizontal alignment, followed by the vertical right, the vertical left, and the diagonal alignment in accordance with the performance accuracy outcomes from the previous study. The layout characteristics in the process flowchart followed the developed design framework that would synergize the strengths of human spatial memory and proprioception facilitating dexterous touchscreen interaction in eyes-free mode. Figure 7.5 shows examples of interface configurations that are developed based on a particular set of requirements and that are generated through the flowchart. The 15-buttons layout was developed in the underlined N shape with an equal distribution in a divided pattern from the centre position. Moreover, the eyes-free interface of the remote control on the touchscreen interface was proposed in the reversed L-shaped layout.

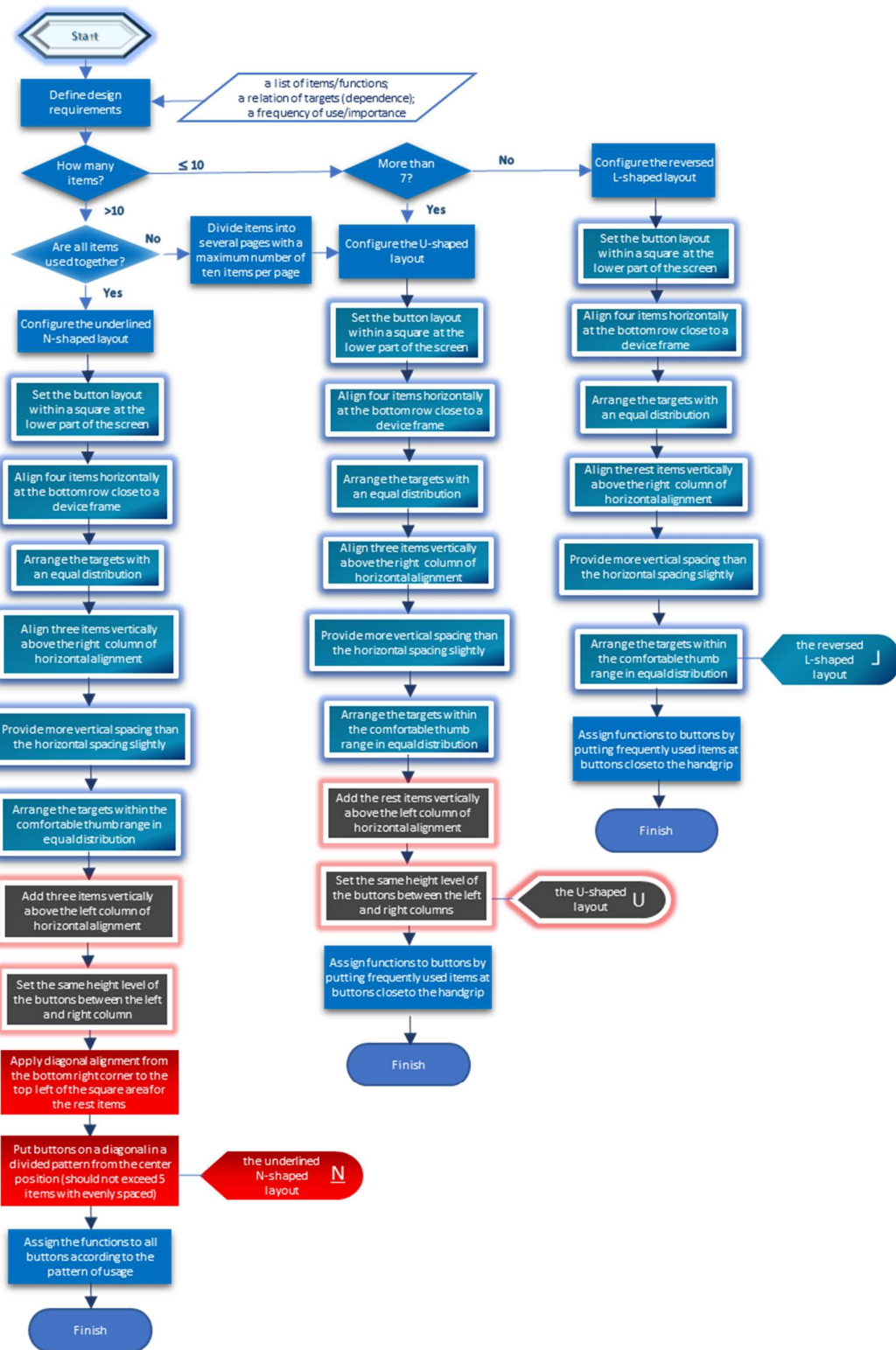
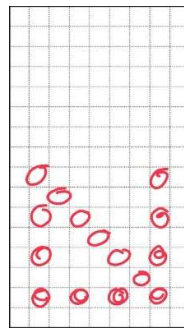

Figure 7.4 The overall process flowchart of designing the effective interface configurations in touchscreen eyes-free application



An example of a layout



An example of an application

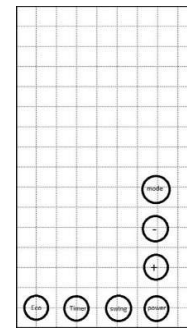

Figure 7.5 The examples of interface configurations

7.3 Evaluation of eyes-free interfaces for applications on a touchscreen

Mobile interaction often involves three main actions such as clicking, moving a pointer, and inputting data (Lorenz et al., 2009). The click action occurs when users intend to choose the command or menu from a screen layout (discrete menu selection). Moving a pointer involves controlling the arrow keys to interact with the grid. Inputting data relates to the data entry interface in which users perform a sequence of text or numeric operations. Therefore, the user interfaces for these tasks are proposed in the usability testing of the eyes-free interface. They include the app selection on the home screen menu on a mobile, directional control with arrows, and data entry on the calculator application.

To design eyes-free interfaces, the layout specification was first considered. This is related to defining the number of items. The home screen menu interface shows a list of options from which the users may choose. This interface aims to provide the shortcut menu, thus there should not be too many interface items on each page. The number of nine items and one accessibility menu were chosen for the home screen shortcut applications. The accessibility menu was used to search for more menu options. Therefore, the U-shaped layout was adopted for ten items per page of the home screen menu. Lastly, the icon names or applications were assigned to each button, providing the semiotic meaning of the menu.

The arrow control interface consists of 5 items, including the left, right, up, and down keys to control the arrows, and one OK button to register the selection. Thus, the reversed L-shaped layout was adopted and assigned functions to buttons with a congruent arrow direction. The up and down arrows were on the vertical axis and the left and right arrows were on the horizontal axis. In the end, the OK button (an important and frequently used item) was placed at the lower right corner close to the handgrip, being the anchor point of the layout.

Finally, the calculator interface was designed for basic calculation. Therefore, it contained a 10-number key, 6 operators (plus, minus, multiplication, division, equals sign, and decimal point), and 2 basic functions (percentage operator and all-clear (AC) function). As the number of calculator interface elements was more than ten items, the underlined N-shaped layout was implemented. The functions of buttons were assigned according to the pattern of usage. The ten number pads were put on the U-shaped pattern while the operator symbols were put on the diagonal alignment enclosed within the U-shaped pattern. Due to the limited area for putting targets, two operator symbols were assigned to one position. The users were required to perform one tap for the first operator sign and a double tap for the second sign. The dot and equals sign at the centre position was the point of symmetry of the diagonal pattern. Diagonally, the plus and minus signs and the multiplication and division signs were located above and below the centre position while the AC function and the percentage key were put at the top and bottom edges, respectively.

The positions of alignment and the shape of buttons were slightly adjusted. The centre of horizontal alignment was slightly shifted to the right since the outcome from the previous experimental results showed that the trend of the touch position was toward the right of the target centre. The height of horizontal alignment was slightly levelled up according to the experimental finding that the participants tended to touch the button above the centre of the targets. These settings were applied to all prototype layouts. Finally, the capsule buttons were adopted to increase the hit rate for the three operator buttons at the centre of the calculator application. Figure 7.6 illustrates all the prototypes of user interface design for touchscreen applications in comparison with the conventional formats.

To evaluate these new user interface prototypes on how practical such eyes-free interfaces could be operated, learned, and memorised, a comparative study was conducted between the conventional user interfaces and the new formats. The conventional format of the home screen menu was the 5x2 grid format in comparison with the new format of the U-shaped layout. The conventional arrow key in the plus-shaped format was compared with the new arrow format of the reversed L-shaped layout. With the interaction in the eyes-free mode, the location of the conventional arrow format was placed close to the screen edge at the bottom right corner. By using the new format of arrows, the right arrow key in the old format was placed at the same position as the down arrow key while the down arrow key in the old format was placed at the same position as the right arrow key. Finally, the conventional 5x4 grid layout of a basic calculator application was compared with the new underlined N-shaped layout format. The dimensional specifications of all layouts are shown in Appendix 8.

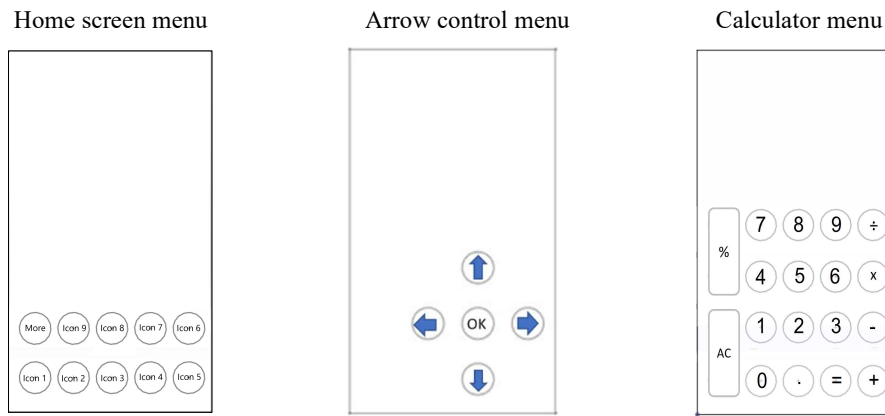

(a) conventional formats



(b) new formats of eyes-free user interfaces

Figure 7.6 The conventional formats of user interfaces and prototypes of eyes-free user interfaces

The research on the practicality of eyes-free interface prototypes consists of two phases. Figure 7.7 shows the protocol for the first phase. The study started by distributing a questionnaire to the participants. Eleven participants who were touchscreen mobile phone enthusiasts were recruited to take part in the study. The questionnaire asked about the perception of the interface configurations between the conventional and new formats. Based on the questionnaire result, the usability study was set out to examine the effectiveness and satisfaction of eyes-free interface prototypes. The following sections show the details of both studies respectively.

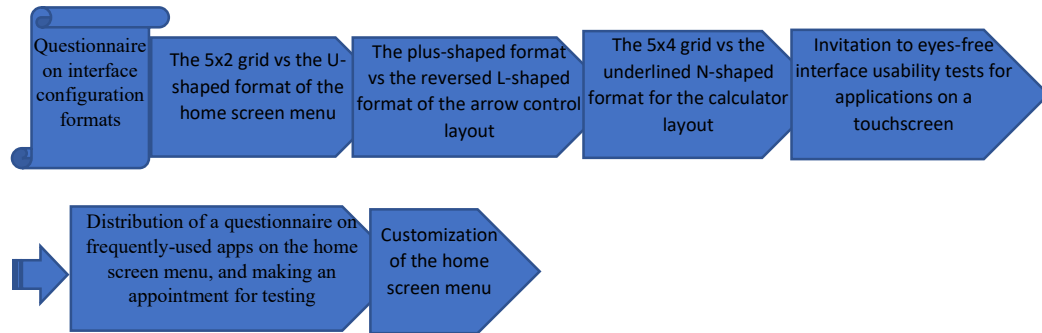

Figure 7.7 Study protocol on the first phase of eyes-free interface prototypes

7.3.1 Participants

There are 11 right-handed participants (7 female, 4 male) who are voluntary to both phases of the study. They are between the ages of 26 and 42 (mean=34.1, SD=5.2) and speak a language with left-to-right script. Moreover, those participants use different models of mobile phones with 9 different screen sizes from 4.7 inches to 6.7 inches. The screen width ranges from 67.3 mm to 78.1 mm. The screen height ranges from 138.4 mm to 162.6 mm. The average aspect ratio of the participants' mobile screens is around 1:1.79. It has a range from 1:1.61 to 1:1.87, which is equivalent to the aspect ratio of the prototype layout interface (1: 1.78) in portrait mode. All of the participants are familiar with their touchscreen mobiles. Their experience with the current mobile is from 8 months to 3 years by 1.5 years on average.

7.3.2 Questionnaire design and results on interface configuration formats

The practicality of an eyes-free interface application on a touchscreen under one-handed thumb interaction involves not only the interface performance but also the users' cognitive and affective responses. The design involves the relationship between humans and technology (Piebalga and Yung, 2014), suggesting the importance of both usability and human-centeredness features in order to create a balanced and safe novel design. Therefore, the study began with measuring the subjective response to the perception of interface configuration formats from participants through a questionnaire. The questionnaire was compared between the two layout formats related to the perceived workload for the home screen menu, arrow key control, and calculator application layouts. The participants received pictures of interface layouts along with the online questionnaire on their mobiles.

Two questions about the mental demands and physical efforts to interact with each layout on a mobile device in the eyes-free mode were estimated by the participants using a 7-point scale, anchored at the endpoints with the terms "very low" for 1 and "very high" for 7. To exemplify, the first question relates to learning and memory on interface configurations while the second

question relates to thumb and hand control issues among three sets of conventional and new format layouts. For these reasons, there are a total of 12 questions for 6 layouts comparison in Figure 7.6. Appendix 9 shows the survey questionnaire.

The survey result is presented in Fig. 7.8. The average (grey) line shows a downward trend in the workload on the new format of home screen and calculator layouts but an upward trend in the workload on the new format of the arrow control layout. The score on the layout indicates that, on the home screen menu, the mental workload significantly decreases in the new formats as opposed to the conventional layout. This implies that the U-shaped layout based on the established design principles may be able to lower users' workload. In touchscreen eyes-free interaction, the button alignment should be provided with more spacing size in separate areas to lessen the risk of error. Though the 5x2 grid menu interface is put close to the screen frame, it requires much users' effort in spatial discrimination as the conventional layout contains five buttons with two rows aligned close together. On the other hand, the U-shaped layout contains four buttons with one row aligned in separate areas along the left, right, and bottom edges, including the increased spacing size between buttons. Thus, the U-shaped layout or the new format of the home screen menu is better for eyes-free interaction.

However, the survey result revealed no significant difference in the average score between the conventional format and the new format of the arrow control layout. The participants rated a lower physical workload on the new arrow format, but they found that the new format layout evoked much more mental workload than the conventional one. Overall, the new arrow format had a slightly higher workload than the conventional arrow format. The probable reason might be that there was no difference in spacing size between buttons in the conventional and the new formats. In other words, participants might consider both layouts demand comparable effort. In addition, the number of interface elements on the arrow control layout (5 buttons) was not many as opposed to the home screen layout (10 buttons). As a result, the participants evaluated a lower mental workload on the plus-shaped familiar layout. Indeed, the new arrow control format in the reversed L-shaped layout requires more effort in learning and practising.

For the calculator layout, it was found that both physical and mental workload decreased significantly in the new formats as opposed to the conventional layout from participants' point of view. One possible reason might be the calculator layout in the new format (15 buttons) has a decline in the number of buttons than the conventional layout (18 buttons). Similar to the 5x2 grid on the home screen layout, the conventional grid menu interface of the calculator application requires much users' effort in spatial discrimination as it contains five buttons with four rows aligned close together. On the other hand, the underlined N-shaped layout contains

one alignment in separate areas on the left, right, bottom, and diagonal. This lessens the risk of error and provides the natural thumb posture orientation from the common anchor point at the lower right corner. Thus, the underlined N-shaped layout or the new format of the calculator menu could bring many benefits to interact with in eyes-free mode.

The survey results and the above reason provided that the U-shaped and the underlined N-shaped layouts were superior to the conventional formats for eyes-free interaction, so the conventional 5x2 and 5x4 grid menu layouts were excluded from the second phase of the study. The comparison of the conventional and new formats was examined on the arrow control menu only. The question given on the test for the arrow control layouts was whether there was a difference in accuracy between the conventional format and the new format. The home screen menu and calculator layout were therefore examined on other aspects of spatial memory and proprioception instead.

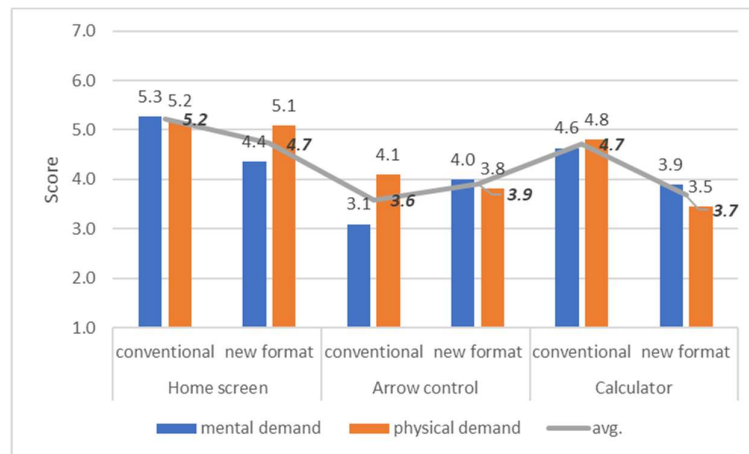

Figure 7.8 Survey results among three types of layouts

It was found that custom menus enhance users' experience (Schade, 2016). The custom menu is the menu where users have their own arrangement of their app icons. On the other hand, the default menu is a standard set of interfaces where users cannot change positions intentionally. In addition, the specific menu involves a formal arrangement of icons. In this case, it refers to the calculator menu. Thus, the experiment is set up further for the menu layout so as to examine the effect of cognitive and affective aspects on the performance accuracy and satisfaction evaluation.

For this reason, the questionnaire about Frequently Used Apps was distributed to the participants before conducting experiments. The participants were offered a chance to choose the preferred apps of the home screen menu and arrange positions for Icon 1 to Icon 9 by themselves. The custom menu layout would be configured according to the participants'

answers. Finally, the custom menu would be tested in comparison with the default menu and the specific (calculator) menu. The question given on this test was whether there was a difference in the participants' perception and performance accuracy on the custom menu, calculator menu, and default menu.

7.3.3 Task design and experimental procedure in the usability study

Parhi et al. (2006) illustrated that single-target (discrete) and multi-target (serial) tasks caused different performances. Therefore, the usability experiment was designed for discrete pointing and serial inputting tasks. The experimental tasks were divided into 3 sessions. The first session was to test the discrete tasks for target selection on the custom menu, default menu, and calculator menu. Figure 7.9 shows the three menu layouts tested in Session 1. It should be noted that the apps for the custom menu were different among the participants (Figure 7.9 (a) is an example menu of one participant). Session 2 and Session 3 are designed for serial tasks. Two arrow layouts (the conventional and new formats) were tested for navigation tasks, followed by data entry tasks of the calculator layout (Figure 7.10).



Figure 7.9 Single-target selection tasks

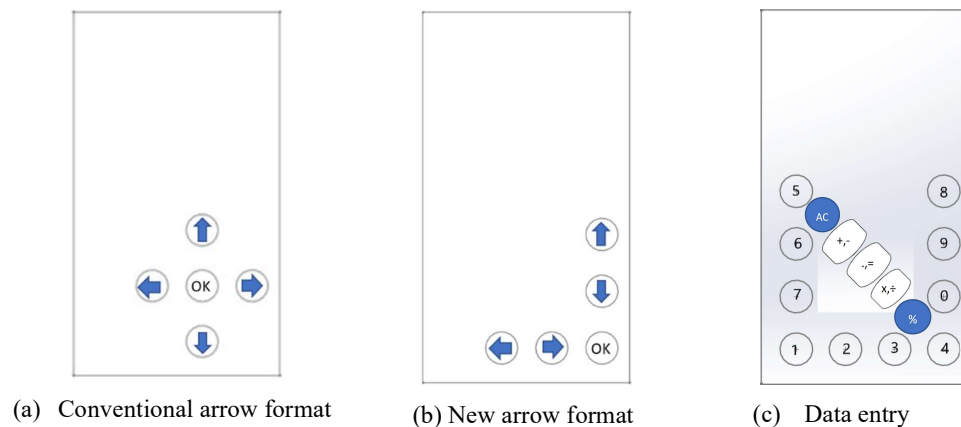

Figure 7.10 Serial-target selection tasks

The experiment was conducted remotely via the participants' mobile together with a Zoom meeting on the desktop. The mobile screen-recording app developed in the previous study in Chapter 6 was adopted in this study without using the bespoke audio stimulus. This app provides the on-screen touch coordinate that can be recorded and visualised in real-time. Figure 7.11 shows the usability study protocol.

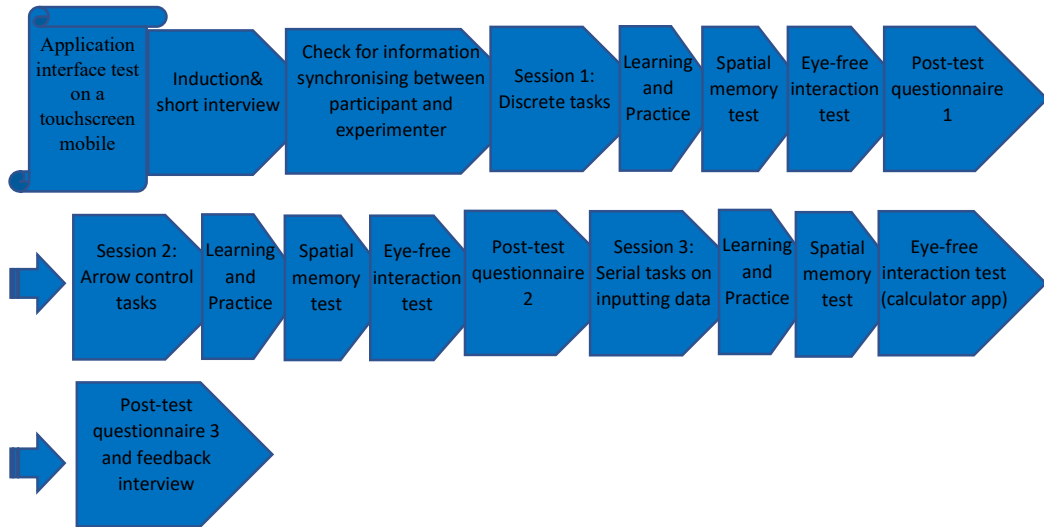

Figure 7.11 Study protocol on the second phase of eyes-free interface prototypes

The protocol started with the participants being introduced to the study details via the experimenter's presentation slide in the Zoom meeting, following with a short interview regarding their handedness and experiences with mobile phones. After that, the synchronisation of the data between the controller web page and the participants' mobiles, was checked.

In the learning and practice period, the participants were presented a picture of the interface via a remote slide presentation, and given time to remember it before the picture of the layouts disappeared from the desktop display. Vandierendonck and Szmalec (2011) suggested that the working memory seemed to be recalled better for the representation of four objects. As the number of objects on the tested layouts was more than four items, the spatial memory test was required to ensure that the participants recalled the spatial layout before the eyes-free interaction test. Figure 7.12 shows the blank button layout used in the spatial memory test. The participants were asked to indicate the button name verbally according to the button pointed by the experimenter for the custom menu, default menu, calculator menu, and the new and conventional arrow layouts. All the positions were tested randomly, and the participants were required to recall all the buttons correctly via their vocal responses before proceeding with the tapping test on their mobiles.

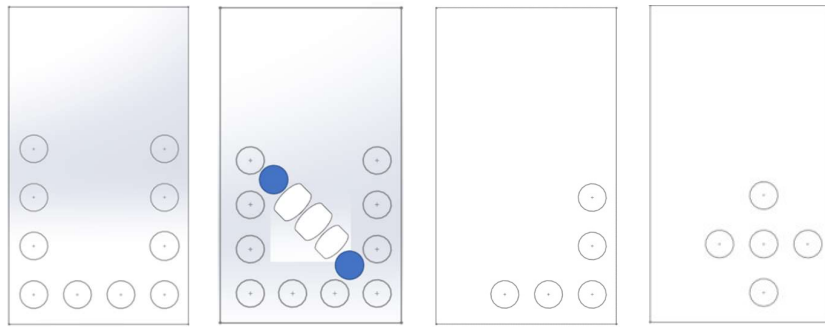

Figure 7.12 The blank button layout used in the spatial memory test

In the usability test, the participants were requested to interact with the spatial location of each layout on their mobiles in an eyes-free mode as accurately as possible because there was no augmented feedback provided. They need to rely only on their spatial memory and proprioception. During this test, the participants' responses were being monitored by the experimenter via the participant view at the Zoom meeting.

In Session 1, the experimenter randomly called the icon/button names in three menu layouts, and the participants needed to respond to the vocal commands accordingly. The vocal commands were pre-selected and identical across the participants. There were 35 touch actions in this session. Then, in the second session, visual commands were adopted. The grid map was presented to the participants on the desktop screen. The participants had a mission to control the arrow keys from the start cell to the end cell. Finally, they needed to tap on the OK button to finish the mission. Each layout was tested with a total of 17 touch actions. Thus, there were 34 touch actions in this session. In Session 3, the visual command of scenarios was also presented on the desktop screen, where the participants were required to input data serially on the calculator layout. The calculation equation was provided to facilitate the activity. A total of 42 touch actions occurred in this session. Figure 7.13 shows the example of commands and tasks given in the test.

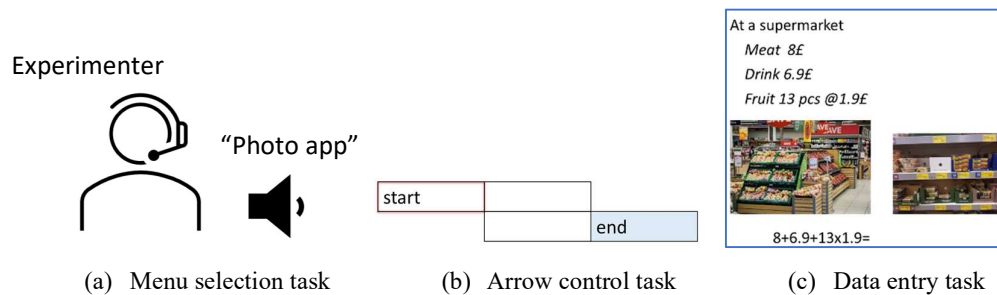

Figure 7.13 The example of commands and tasks given in the test

After completing each session, the post-test online questionnaire was distributed to the participants for evaluating their satisfaction levels. The participants rated their feelings on the layouts by using a 7-point scale (1= very low, 7= very high). The three questions were about the quickness level for the response, the difficulty level in using the layout, and the confidence level to hit the target. Thus, there were a total of 18 answers given to 6 tested tasks.

In the end, the participants were queried with their feelings and experiences with eyes-free interfaces. They also had to decide on which one of the arrow control layouts they preferred without acknowledging the performance accuracy. The experiment took around 90 minutes.

In summary, the usability experiment of eyes-free interfaces for applications on a touchscreen was designed to test the performance accuracy and satisfaction evaluation between the custom menu, the default menu, and the calculator menu, between the conventional arrow format and the new arrow format, and between the discrete task and serial task.

7.3.4 Measures and data analysis

The performance accuracy of all control interfaces was examined by calculating the mean distance error. The length of a line segment between the touch position (response outcome) and the target centre position was the distance error. The data processing method the same as in the previous chapter was adopted to transform all the touch coordinates recorded from each participant's mobile screen dimensions into a common unit by the proportion of the screen width.

The value was compared to the target size of 14 units under the 90 units of screen width. The higher the mean distance error, the poorer task performance. Then the scores from the post-test questionnaires were analysed. The higher the quickness level and confidence scores, the better the user satisfaction level. The lower the difficulty score, the better the user satisfaction level.

Lastly, the normality test of data was done before analysing the inferential statistics. The one-factor repeated-measures ANOVA in Minitab 19.0 was used for analysing the results that were the normal distribution. The outcome of the analysis that had a value of p less than 0.05 was statistically significant. This value criterion indicated, in terms of performance accuracy and satisfaction of the participants, whether there was a significant difference among layouts and whether there was a significant difference between the discrete task and serial task.

7.3.5 Results

There were 1,221 touch points and 198 score data collected from the 11 participants. It was found that the data sets followed a normal distribution. All the results on the mean distance

error and satisfaction score are presented in Table 7.1 for the menu layouts, calculator layouts, and arrow layouts, respectively, grouped with the tested factors. Tapping outcomes are illustrated in the pictures of the layouts in Figure 7.14. Appendix 10 shows a supplement of touch coordinate data. The analysis of the findings is compared to the performance accuracy and satisfaction level as follows:

Table 7.1 Descriptive statistics of all tests

| Tests | Factors (layout) | Performance accuracy | | Satisfaction level | | | | | |
|---------------------|---|------------------------|------|--------------------|------|-----------|------|------------|------|
| | | Distance error (units) | | Difficulty | | Quickness | | Confidence | |
| | | Mean | S.D. | Mean | S.D. | Mean | S.D. | Mean | S.D. |
| Custom menu | Customizable feature (home screen menu) | 9.72 | 3.59 | 3.64 | 1.91 | 5.73 | 1.10 | 5.46 | 1.44 |
| Default menu | | 9.31 | 2.74 | 5.18 | 0.98 | 4.18 | 1.25 | 4.09 | 1.38 |
| Discrete task | Kind of tasks (calculator menu) | 9.55 | 2.57 | 3.73 | 2.10 | 4.46 | 2.02 | 4.64 | 1.80 |
| Serial task | | 11.43 | 4.20 | 3.64 | 1.96 | 4.82 | 1.40 | 4.64 | 1.96 |
| Conventional format | Format of layouts (arrow layout) | 12.01 | 4.62 | 2.82 | 1.94 | 6.27 | 0.79 | 5.73 | 1.35 |
| New format | | 8.79 | 2.97 | 3.64 | 1.69 | 4.64 | 1.43 | 4.27 | 1.90 |

7.3.5.1 Performance accuracy

The data set of mean distance error was analysed by using the repeated measures ANOVA to examine the effect of interface prototypes and the kind of tasks on performance accuracy. The ANOVA revealed that mean distance errors were significantly different among the 6 tests ($F_{5,10} = 2.43$, $p=0.041$). However, the mean distance errors in discrete tasks were not significantly different among the custom menu (9.72), the default menu (9.31), and the calculator menu (9.55). The ANOVA also showed that the mean distance error of the calculator layout was significantly different between the discrete and serial tasks. The mean distance error increased on serial tasks (11.43). The dramatic effect of the layout format was observed in the arrow layouts. The performance of the new arrow format (8.79) in the reversed L-shaped layout was significantly better than the conventional arrow format (12.01).

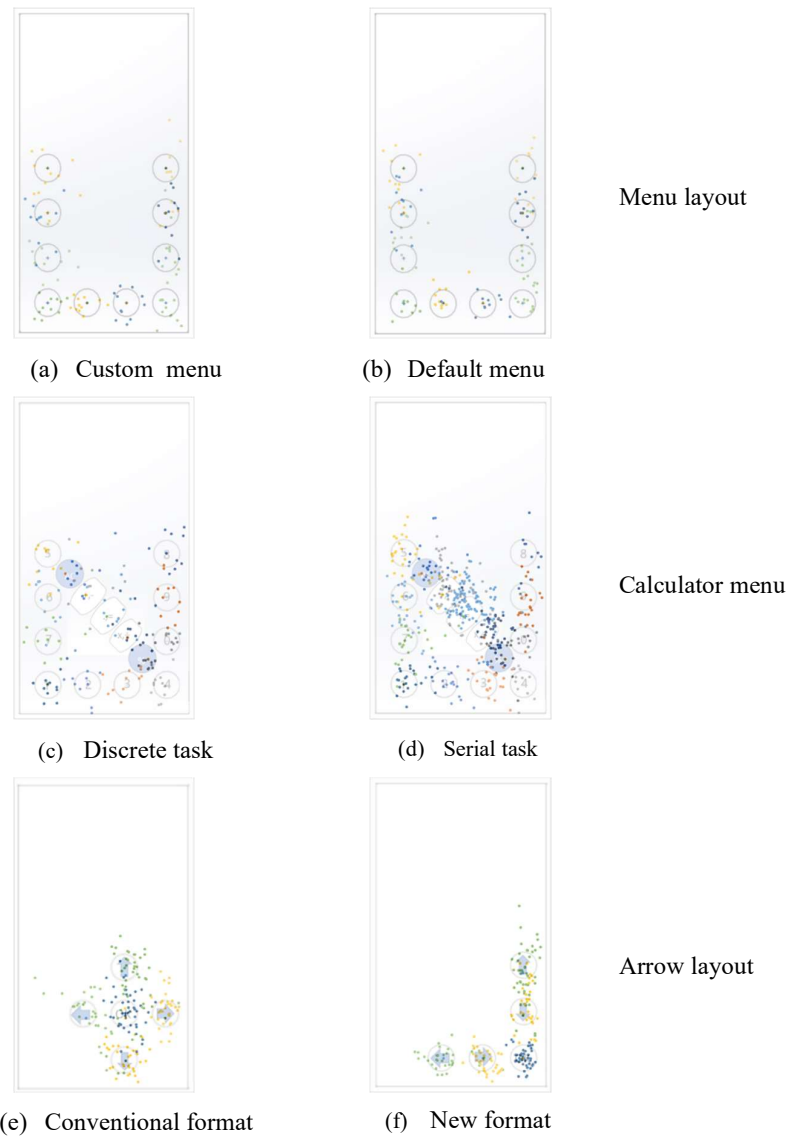

Figure 7.14 Outcomes of all tests

Looking closer at the button accuracy in two layout formats, the mean distance error of buttons in the arrow layouts was provided particularly in Table 7.2. For the conventional arrow format, it was found that mean distance errors on the left (15.5), up (15.3), and OK (10.6) buttons were higher than those on the right (9.3) and down (8.9) buttons. The right and down buttons were put in proximity to the screen frame. This implies that buttons aligned close to the screen frame provide better performance accuracy than those inside areas. On the other hand, the mean distance errors on the up (11.8) and down (11.0) buttons on the new arrow format were higher than those on the left (9.4), right (7.1), and OK (4.9) buttons. The lower right corner button provides the lowest mean distance error. Buttons aligned horizontally are found to provide a

smaller mean distance error than buttons aligned vertically. It seems that the closer the button position from the anchor point or the handgrip, the less the mean distance errors.

Table 7.2 The mean distance error (units) of buttons for the conventional and the new formats of arrow layouts

| Layouts | Buttons | | | | |
|---------------------|---------|------|------|-------|------|
| | Up | Down | Left | Right | OK |
| Conventional format | 15.3 | 8.9 | 15.5 | 9.3 | 10.6 |
| New format | 11.8 | 11.0 | 9.4 | 7.1 | 4.9 |

7.3.5.2 Satisfaction evaluation and interview

The satisfaction evaluation consists of participants' rating on the difficulty, quickness, and confidence levels after completing the tasks on each layout. Figure 7.15 shows the bar chart of the score on each layout regarding the difficulty, quickness, and confidence levels.

The ANOVA revealed that there was a significant difference among layouts on the difficulty level ($F_{5,10} = 15.00$, $p=0.00$), on the quickness level ($F_{5,10} = 22.42$, $p=0.00$), and on the confidence level ($F_{5,10} = 22.27$, $p=0.00$). The default menu layout provided the highest difficulty level, the lowest quickness, and the lowest confidence level while the conventional arrow format provided the lowest difficulty level, the highest quickness level, and the highest confidence level. The feedback scores in the discrete tasks were different among the custom menu, the default menu, and the calculator menu. According to the participants' viewpoints, most satisfaction was derived from the custom menu, followed by the calculator menu. The default menu obtained the lowest score of satisfaction. It was found that all feedback scores on the calculator layout were similar between the serial and discrete tasks. In arrow control layouts, it was clear that the conventional format got great satisfaction toward the participants' viewpoints as opposed to the new format layout.

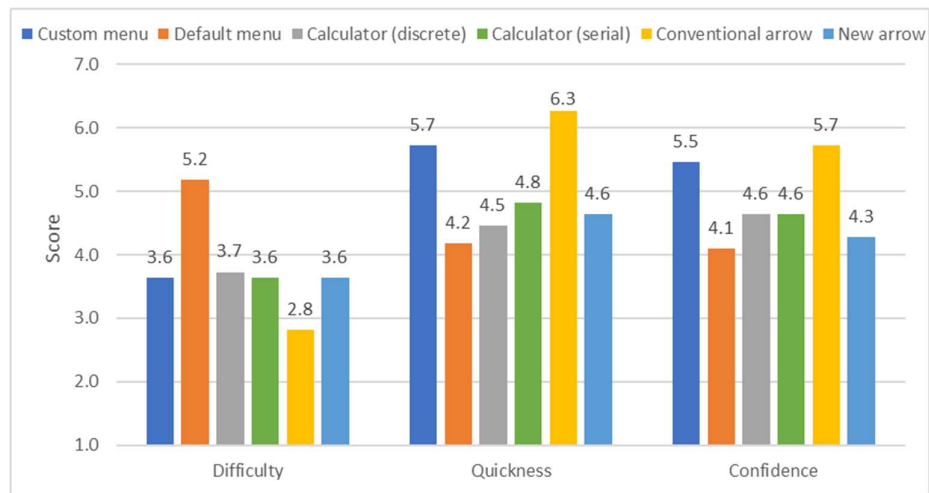
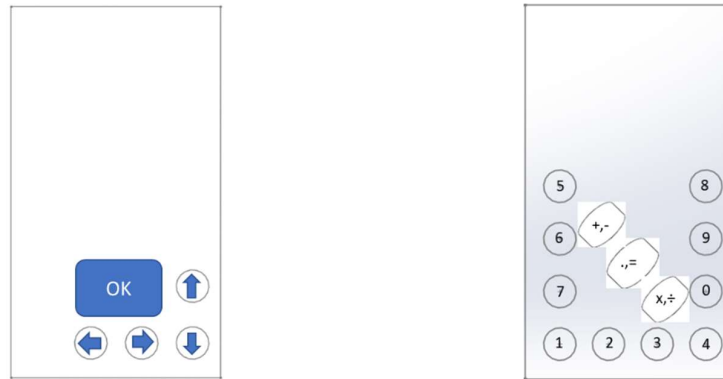

Figure 7.15 Participants' feedback to interfaces after completing tasks

According to the interviews, 8 out of the 11 participants favoured the conventional arrow format compared to the new format of the arrow control interface. One participant who likes the conventional format mentioned, “when you want to click downward you move your finger accordingly while the down arrow on the new format requires the upward movement”. Most participants commented that the conventional arrow format was intuitive and easy to understand, but it lowered their confidence level to touch the target accurately. On the other hand, the new arrow format was easy to remember though it was quite difficult to become accustomed to. Some participants also gave suggestions on the improvement of the new arrow format. They indicated that moving the up-down arrows one step to the bottom line and moving the OK button toward the diagonal of the screen (the central part) might be proper and easy to use in comparison with the design where the down key is located above the OK button. Thus, the affective aspect should be considered as well for intuitive design. On the calculator interface, they shared their opinions that the number pad was well-organised. However, the operator buttons were too dense for them. One participant indicated that three buttons were optimal and a swipe gesture could be applied for the two remaining functions. Figure 7.16 shows the visual presentation of the interface configurations from participants' suggestions. For the arrow layout, the intuitive approach of arrow direction enhances user perception, and the orientation far apart from each other lowers the mistake. For the calculator layout, it was suggested to increase the button spacing for ease of use. The other stated that these interfaces were easily controlled using only one hand. Overall, they valued an eyes-free interaction as their attention to primary tasks would not be inhibited by smartphone interfaces.



The more intuitive approach to arrow keys The reasonable number of buttons and ample button spacing

Figure 7.16 The participants' suggestions on the interface configurations

7.3.6 Discussion

For the menu layout, although there is a difference in the participants' perception of the custom menu, default menu, and calculator menu, the performance accuracy on the mean distance errors in discrete tasks was not significantly different among them. The satisfaction levels on the custom menu were higher than those on the default menu. The participants felt that they recalled button positions on the custom menu layout easily as they had assigned and arranged menu positions by themselves. Therefore, this layout was very satisfying as opposed to the default menu layout which had the same 10 buttons U-shaped configuration. Moreover, it was found that the satisfaction levels on the default menu were lower than in the calculator menu which had buttons up to 15. It was supposed that the default menu demands much more mental effort for semantic learning. The calculator menu had a sequential number pad and harmonious relationship among the calculation operators. Thus, the participants were able to see the logic behind the calculator menu to alleviate their mental workload.

Interestingly, performance accuracy on the U-shaped layout of the custom and default menus was also similar to the one on the underlined N-shaped layout of the calculator menu. The underlined N-shaped layout consists of additional five buttons aligned diagonally as opposed to the U-shaped layout; however, it gave a comparable performance with the U-shaped layout. The diagonal alignment provided the symmetrical feature and applied the point symmetry. This could confirm that the feature of symmetry in a square within the design framework and design guidelines were valid.

To sum up, the customizable feature and the logical feature of the menu might provoke the emotional aspect but not impact the cognitive ability such as spatial memory and proprioception. Hegarty (2011) asserted that the visual-spatial display augmented cognition and a good design could afford the cognitive task. The results suggested that assigning

semantic relations logically and offering a customizable user interface are also important for the eyes-free interface since it lessens the burden of cognition on perception and increases satisfaction levels.

For the serial task on calculator layout, although the satisfaction levels are still the same as the discrete pointing task, performance accuracy is significantly different. It is obvious that the serial data entry deteriorates performance accuracy because it requires several touch actions and orientations. Thus, it had better increase the target or spacing sizes of the buttons for the layout used in a serial data entry task. For the serial task on the arrow layouts, although the new format of the arrow control interface reduces physical demand, the participants viewed that it requires higher mental demand compared to the conventional arrow layout. As a result, this new format fails to attract participant preference. However, the practical outcomes of the mean distance error prove the effectiveness of the new format of eyes-free interfaces. The probable cause might be that the three buttons on the conventional arrow format configured in the plus-shaped format are located inside the array with different rows and columns in the central area. Therefore, the participants had to rely on their spatial discrimination of the two-dimension. In contrast, the new format layout demands one-dimensional discrimination as it is configured close to the device frame, so it requires the participants' movement along the thumb flexion direction only. Thus, the interface configuration on the new arrow format provides better performance accuracy. To gain acceptance of the new arrow format layout, the semantic design should be improved in accordance with the movement to enhance the user experience. In other words, the effective interface configuration should be considered along with the cognitive, affective, and ergonomic design.

The outcome patterns also show that buttons aligned horizontally in all the layouts still provide the best task performance, followed by those aligned vertically on the right and the left, and diagonally. These conform with the findings in Chapter 6. The design framework and design guidelines are practical.

The movement along the horizontal bottom alignment shown in Figure 7.17 (a) requires only varying the pitch angle (folding finger) as the thumb put parallel to the bottom edge at the same level of the handgrip is comfortable and natural. As a result, performance accuracy on buttons along the horizontal alignment is superior. Moreover, it was found that the button at the lower right corner in Figure 7.17 (b) is restricted with both two edges and closest to the anchor joint or the handgrip, therefore providing the best performance accuracy. The buttons on the vertical right also provide good performance accuracy as they are close to the handgrip and palm, despite requiring more pitch and roll angle (Figure 7.17 c).

On the other hand, though the vertical left alignment is far from the anchor point, it is close to the device frame, providing effective stimuli from device cues (Figure 7.17 d). Finally, it was found that the thumb that is diagonally put from the bottom right corner in Figure 7.17 (e) and (f) are natural thumb posture orientation. This alignment clearly splits apart from the horizontal and vertical edges. Therefore, different orientations could help to reduce the mistake when interacting in eyes-free mode. This could ensure that eyes-free interface layouts within the design framework and guidelines are valid.

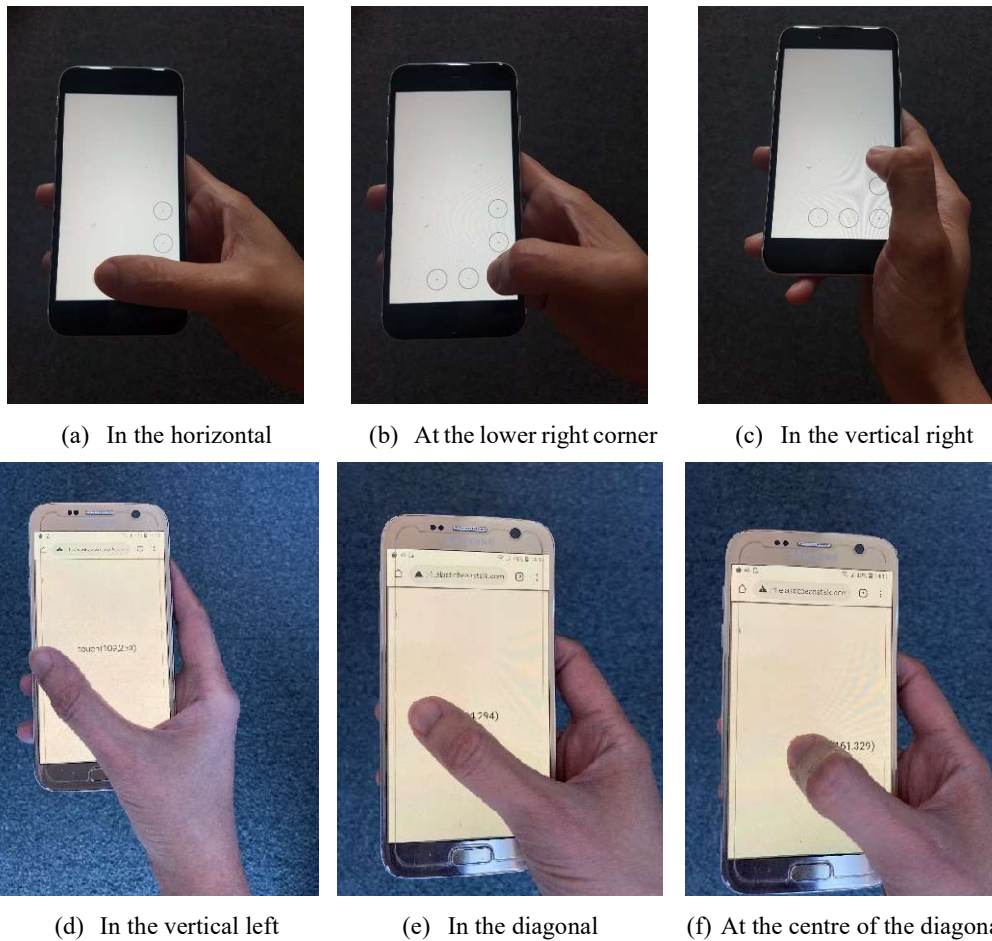

Figure 7.17 The illustrations of the ways to touch, reach and move the thumb when using the interface (Only the top row made an example with the visual interface)

Abascal (2018) suggested that new technologies should not require too much effort from the users. Piebalga and Yung, (2014) demonstrated the design direction that relates to the relationship of technological design to humans. In this study, the new interaction technique and interface design for the touchscreen mobile were adopted accordingly. It was found that the participants were able to learn and memorise the spatial interface within a short time under the cognitive capacity of visual mental imagery. The human ability of proprioception to

navigation results from sensory cues and the sensorimotor system causing a precise response. Tversky (2003) suggested that both local environmental cues or landmarks and human proprioception promote performance accuracy. The experimental results showed that the participants could make spatial discrimination on the layout by relying on their spatial memory and proprioception in touchscreen eyes-free interaction. They could construct their visual and mental imagery based on spatial interface learning on the layout presented indirectly on the remote display and could deduce the solution to interact on touchscreen mobile in an eyes-free mode. A new interface design could utilise the user's spatial memory and proprioception to allow interaction with smartphones better. The experiment provided insights into the design framework on the practicality of user interface applications.

7.4 Interviewing with user interface designers

The semi-structured interviews were conducted with experienced user interface designers so as to gain insights into the interface configuration design and collected their opinions regarding the design framework and the design guidelines that would support effective eyes-free interface configuration of touchscreen interfaces. The user interface designers are the primary stakeholders who would apply the guidelines, thus their feedback was essential. The triangulation approach was adopted within this research involving the researcher, the users, and the practitioners. Furthermore, to convince the user interface designers, they were presented with empirical evidence from the previous usability study on the effectiveness of eyes-free interface configurations.

To avoid biased opinions in the validation phase, a strategy in the interview process was adopted differently from the research process. In other words, the way the interview was structured, and the set of interview questions raised would be set in the opposite direction from the research methodology. The steps proceeded from the practical context, then backward to the fundamental theoretical framework. The interviewees could see the applications of eyes-free interfaces that are practical knowledge and provide their own opinion before having a demonstration and explanation of the proposed design guidelines and rationale on the conceptual framework behind these findings from the researcher. To exemplify, the protocol started with asking for expert practices on designing the eyes-free layout. Then the presentation of the effective eyes-free layouts and the design guidelines were provided, followed by a description of the theoretical framework at the end. The final outcomes focus on the feedback concerning the importance and potential effectiveness of the principles of spatial memory and proprioception as well as the usability and practicality of the flowchart for designers in general. The next section presents the interview methodology in detail .

7.4.1 Methodology

Four designers, consisting of two senior user interface designers from a multinational technology company, one senior user experience designer from a creative company in Thailand, and one graphic and industrial designer of innovative products from Australia who has experience in designing automotive interior touchscreen dashboards, were interviewed. Although they have current experience with direct visual interfaces, in many cases, interface design is targeted at dexterous operation and ease of use under a reduced level of visual attention. These aims are in accordance with the design goal of eyes-free interface design. Therefore, their experience and feedback would be beneficial and help with the recommendation of the general usability and practicality of the eyes-free interface. Table 7.3 presents the profiles of the four designers.

Table 7.3 The profiles of experienced user interface designers

| Expert | Company | Professional | Gender | Age | Experience (Yr.) | Type of design |
|--------|---------|------------------------------|--------|-----|------------------|-------------------------------------|
| 1 | A | UI designer | Female | 37 | 7.5 | Mobile applications |
| 2 | A | UI/UX designer | Male | 35 | 10 | Touchscreen Remote app |
| 3 | B | UX designer | Male | 29 | 7 | Mobile applications |
| 4 | C | Graphic/ industrial designer | Male | 27 | 4 | Car dashboard touchscreen interface |

Each interview was conducted online via Zoom meeting and took approximately one hour. A pre-determined set of questions was adopted in the semi-structured interview. This offers the researcher an opportunity to explore particular themes further depending on the response to the main question. The answers would be interpreted to bring about insights into the characteristics of interface configuration facilitating the human perception and dexterous eyes-free interaction on the touchscreen.

The interviews were separated into three sections: an introduction to the eyes-free interface design; a presentation of eyes-free interface configurations and an understanding of the flowchart for the eye-free interface design process; insights into characteristics of eyes-free layout on touchscreen devices and a discussion of the design framework (see Appendix 11 for more details regarding the interview questions, and the provided information about the design flowchart and design framework for the eyes-free interface). The designers consented to take part in the interview that would be recorded, transcribed, and evaluated. The responses

identified from the transcripts included the importance and potential effectiveness of the principles of spatial memory and proprioception under the design framework as well as the usability and practicality of the flowchart. Appendix 12 shows interview transcript example.

Firstly, in section 1, the designers were asked a few questions about their background and layout design experience. Then, they were introduced to the concept of designing an eyes-free interface relating to spatial memory and proprioception. These were input interface configurations for controlling devices in eyes-free mode. The slide presentation with a set of questions was shown to the designers. The next question was raised for the design of three layouts in a group of 11-15 icons, 8-10 icons, and 4-7 icons for eyes-free interaction. The experts were requested to identify their practices in arranging mobile interfaces for these kinds of layouts. These designs were aimed at right-handed people. Certain aspects within the design framework were examined and their practices and opinions were shared in the designed layouts.

In section 2, the process flowchart of designing the effective interface configurations in touchscreen eyes-free interaction was presented. The designers were asked about their understanding before providing an explanation and examples of design layouts with outcome findings on the usability test. Lastly, they were asked to put forward some suggestions concerning the usability of the flowchart.

In section 3, they were introduced to the design framework and were prompted to give feedback on the characteristics of the eyes-free interface under the design framework. Finally, they provided some opinions on the adoption of an eyes-free interface design framework. Following the analysis of the interview transcripts and the designers' recommendations, further refinements were made to the design practices under the flowchart.

7.4.2 Results

Section 1: Background information, the introduction of the eyes-free interface and the layout design practices from the experienced designers

Based on answers about their typical design process and experience, the interviewees are usually involved in designing mobile applications for visual interaction. The design process would first consider the area for putting interface elements, followed by the button size, and segmentation. The theme and graphical aesthetics are the final consideration for visual interaction. They described that the screen layout and design method will be selected based on the type of users, required features (both business and user requirements), and the user journey (activity flow). Most of the designers deal with adopting wireframe templates that are designed

into the grid pattern and follow basic guidelines for visual interface design. The proper layout varied across different platforms. However, there are some design methods for user experience (UX) that they need to follow in every case such as the minimum size of the icon, font and spacing which universally affect all users and all types of apps. In addition, the device model or operating system (OS) needs to be considered as it is a somewhat different approach in the development process.

After the concept of eyes-free interfaces relating to spatial memory and proprioception was introduced to them, all of the designers were interested in the concept of interface design that could harness innate human abilities and product affordances, allowing the reduction of levels of visual attention.

In response to questions about the layout design experience, designers were asked to share their practices in designing interface layouts for eyes-free interaction. The experts were faced with three design problems of eyes-free interface configurations for 11-15 icons, 8-10 icons, and 4-7 icons. Certain aspects within the design framework were examined from their solutions. As a result, their practices and opinions were shared in the layout design configurations. Most of the designers' answers on the eyes-free interface configurations were putting the icons close and parallel with the screen frame in the lower part of the screen where their thumb could reach without repositioning the hand grip. Most button positions were aligned at the bottom row and the right column. One of the designers arranged icons in the upper part, but the patterns of button alignments were similar to the other designers. He reported that because of using his large mobile, his hand would be placed in the centre of mass of the mobile, therefore he could only interact with the upper part of the screen. However, most buttons were still aligned on the area's base along the thumb axis paralleling the screen frame.

Interestingly, it was found that the designers fully applied the corner and screen edge to navigate users under eyes-free interaction. Their intentions were to avoid the top left location and put the majority of icon positions in the bottom right near the anchor point or handgrip. Furthermore, the symmetry feature was also found in the configurations since the designers put icon positions where they could match each other in the way of the other half in a mirror.

Their reason for arranging the interface layouts close to the frame was that the device frame could be exploited as navigation clues. The edge of the phone was important to cue the boundaries where users should place fingers. Moreover, the icons were arranged based on the range of the thumb.

Section 2: Comments on the presentation of eyes-free interface configurations on the design flowchart

In response to questions about the process flowchart, all of the designers were able to understand the steps and identify conditions for each case of layout pattern. They acknowledged the button alignment methods on the screen based on the number of buttons, for example, what kind of layout it should be if there were more than or less than 10 icons. In addition, they were aware that when an eyes-free interface was configured, the button alignment should be put horizontally at first, followed by the vertical right, vertical left, and diagonal alignment. They asserted that the guideline was a toolkit when designing user interface (UI) ergonomics. In other words, the flowchart seemed to fit into their design practices. They often prioritised horizontal button alignment in the first place. As the reversed L-shaped layout and the U-shaped layout are easy to learn and easy to navigate, the designers were interested in adapting these layouts to their works if applicable depending on the number of interface elements designed, to facilitate users' dexterous operation. However, they provided that the underlined N-shaped layout was somehow strange and unsuited to users at this time.

One of the designers suggested adding the guideline for the left-handed users. He supposed that the layout configuration method would be the inverse of the approach for right-handed people. Other comments were queries about adapting design guidelines for a variety of screen sizes and grip positions. It is interesting to note that after further explanation on the square area feature of interface configurations was provided, they believed that the guidelines were applicable for a variety of screen sizes because only half part of the screen was applied in a square area in proportion to the width of the mobile. If users grasp the device at the middle part for the large mobile, the interactable square area could be on the upper screen as opposed to the lower part. However, in whichever case, the base of the eyes-free interface area was still anchored at the handgrip or the thumb knuckle position. To exemplify, the thumb motion forms the parabolic area anchored at the thumb knuckle, consequently the interface area is under an orthogonal area from the west across to the north direction under the parabolic curve. For these reasons, the interface configuration patterns in the U-shaped layout, the reversed L-shaped layout, and the underlined N-shaped layout as suggested are valid.

After the designers were presented with examples of application layouts tested in the experiment, one of the designers commented:

“Aligning buttons at 45 degrees is the resting thumb position when holding the device in portrait mode. It’s a kind of new method, people might not be familiar with the layout and may find it a bit hard in the first place as they need to remember a new pattern”.

Another pointed out that the diagonal alignment was really rare to be used for usual apps though there was no technical issue with the implementation. One designer suggested decreasing the number of buttons on the diagonal.

These emphasised that the interface configuration patterns are novel and need more time for users to learn and approve of the effectiveness.

Section 3: Comments on the eyes-free interface design framework

In this section, the designers provided feedback on the interface configuration characteristics under the design framework reflecting the importance and potential effectiveness of the principles of spatial memory and proprioception.

Area/range of the button placement

The designers addressed that the size of the mobile affects the handgrip position and comfortable functional thumb area and suggested that putting the button at a specific part of the screen could make users recall and interact with the interface easier:

“Buttons should be positioned properly so that users can easily remember at first, resulting in no need to look at the screen next time, and can use the buttons according to their positions accurately”.

The interface area should be under the thumb range and close to the device frame because users would be able to refer to their muscle memory and exploit landmarks of the physical device:

“Reachable thumb areas or along the edges of the device frame; corners and mid sections play the important role in which the user can easily recognise positions without glancing at the screen. This compromises the ergonomics in favour of foolproofing rather than solely reliant on the thumb’s muscle memory”.

Alignment of the button and the button distribution pattern

Most of the designers asserted that aligning buttons straight was proved to be optimal for tapping accuracy and providing ergonomics to interaction. Users were more likely familiar with the structure alignment within the grid and the menu layouts aligned horizontally. However, one of the designers commented on the layout that buttons aligned too close together

may be ineffective compared to having a button on each side's edge. It is interesting to note that separating each button on a distinct area requires a reorientation of each position as opposed to aligning buttons along one axis.

The designers indicated that the sizing of the button and its spacing were important factors that streamlined the app and made it easy to use and effective to interact with. Increasing the target size could help users complete tasks more easily:

“Wide gaps and larger button UI will play a huge role to create better tolerance between users’ recognition and accuracy”.

Unified layout

The designers gave the opinion that having a single set of button configurations would make it easier for the user to build memory, compared to being faced with a diverse set of patterns.

“The unified layout is good as users can find out all functions and easily relate to each other spatial elements, but the interface should be configured with a proper spacing and target size”.

Middle segmentation

Most of the designers affirmed that the middle point facilitates the spatial discrimination process of users under eyes-free interaction since halfway was easy to understand and recognise. Thus, the middle point could be used as another reference point to navigate on the touch screen. One of the designers indicated:

“Normally, when a button is placed in the middle, its position helps emphasise the button as the main feature and users would recognise it as the priority button. For the accuracy, apart from device edge, the middle segmentation can be a good reference for the user too”.

Most designers suggested that the number of three icons would provide better accuracy than four icons according to the middle segmentation feature. Figure 7.18 shows the examples of adopting the middle segmentation feature.

Middle segmentation along the diagonal

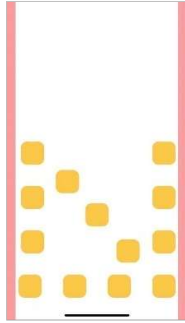

Middle segmentation along the horizontal

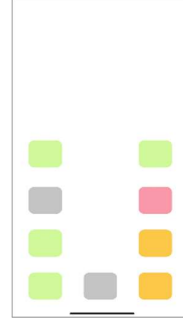

Figure 7.18 Examples of adopting the middle segmentation feature.

Finally, they provided more viewpoints that applying the concept of spatial memory and proprioception to the touchscreen layout design was useful because this would create an easy interaction for the user even without eyes-on. The understanding of spatial memory and proprioception would help them design better interface layouts. Designing interfaces that suit innate human abilities, enhance the user experience. The eyes-free interface design offers users the chance to operate the device with dexterity in the background or periphery of attention without constantly minding where things are on the interface. They learned that interface configuration designed in the horizontal alignment, the middle segmentation, and the symmetry in a square, could strengthen spatial memory and proprioception as well as bring about good performance on touchscreen eyes-free interaction. They said the button should be placed within thumb range and along the edge of the device frame or other landmarks, i.e., corner, midsections, and grooved phone bezel. They supported that having a single set of button configurations with equal distribution would be easier for the user to build spatial and muscle memory (proprioception). These are in line with the established design framework. The designers thought that the integration of product affordance with innate human abilities would be a good direction for an intuitive interface design. That is the interaction with the device will become easier and more comfortable as this effective interface evokes a lower mental and physical workload. Few know how to implement this approach in practice, thus it needs further research and development. Most of the designers stated that the eyes-free interface design was different from their current design approach.

One of the designers commented:

“My current design is based on eyes-on interaction. I think this framework is quite interesting for future app design, especially for some particular activities, such as VR gaming, the app on duty (while driving, while running) and it is also practical for

disabled and elderly people as the design is considered at ergonomics and aimed at better performance with the lower amount of physical and mental effort required”.

All of the designers claimed that this was a novel interface design that would meet user expectations in the digital age for dexterous operation with a lower level of visual attention. Apart from the haptic technology, they believed that the eyes-free interface configurations could be developed and further utilised for this touchscreen design of the input interface or remote controller in the future. They hoped that this would aid the user to get building spatial and muscle memory to sets of button configurations. Interaction with the devices would become easier as the user have got accustomed to the ‘default’ configuration which was similar to touch typing.

7.4.3 Summary of designer feedback

In the interview with the experienced user interface designers, feedback on the importance and potential effectiveness of the principles of spatial memory and proprioception was provided. All of the designers were interested in the concept of eyes-free interface design. Though they have not ever designed interfaces for eyes-free interaction, they were asked to provide their practices and opinions on the layout design configurations. These were implicitly reflected in the interface characteristics assisting eyes-free interaction from their viewpoints. They tacitly agreed on the characteristics of interface configurations that should be considered within the design framework when designing the eyes-free interfaces. That is the configuration in the structure and symmetry pattern and the straight alignment within the area close to the screen frame and comfortable range, and the presentation in the unified frame and middle segmentation contribute to spatial recognition and performance accuracy.

The designers could understand the concept of spatial memory and proprioception. Spatial memory is the cognitive ability to recall the spatial layout. Meanwhile, proprioception is information about the body position sense and degree of muscle stretch from static and dynamic limbs, making a person know the location and orientation of the body parts. They acknowledged that spatial memory could be transferred from the visual interface users have learned or memorized before. That is the users could imagine a spatial layout and interact with the interface correctly in an eyes-free interaction by exploiting both spatial memory and proprioception. They learn that spatial memory makes interaction with a non-visual interface feasible while proprioception help users make spatial discrimination accurately in the absence of vision. Therefore, the users can indirectly and subtly control the interface in eyes-free mode. In addition, they provided feedback on the usability of the flowchart and the practicality of the design framework. Under the design flowchart, the criterion of the number of buttons should

be improved on the underlined N-shaped layout. They addressed that the process flowchart was aimed to guide the way the designer configures the interface layout so the scope for other characteristics the designers had suggested, such as button size and button spacing size, needs further research. The feedback on the design framework and adoption was constructive and favourable. They stated that the framework is essential for human-centred design thinking. They acknowledged key characteristics in designing eyes-free interfaces and further suggested integrating haptic technology into this interface design.

Overall, the designers supported the eyes-free interface design framework, and the design guidelines (process flowchart) and intended to apply the concept of spatial memory and proprioception to the human-centred interface design. After the interview, they were given a version of the flowchart to use in practice.

7.5 Improvement of design guidelines

The findings from the usability testing and expert interview resulted in updating the design flowchart. As the application layouts were configured from the combination of aligned buttons in different directions, they required users to switch between different orientations and had an effect on the performance accuracy. The diagonal alignment provided poorer outcomes as opposed to the button within the U-shaped layout. Thus, the maximum number of buttons in diagonal alignment would be revised to three buttons. Overall, the number of elements on the eyes-free interfaces should not exceed thirteen items. It was suggested that other approaches such as line drawings and stroke gestures could be applied to additional interaction vocabulary. Thus, these would be updated onto the flowchart under the underlined N-shaped layout. Figure 7.19 shows the updated version of the design flowchart.

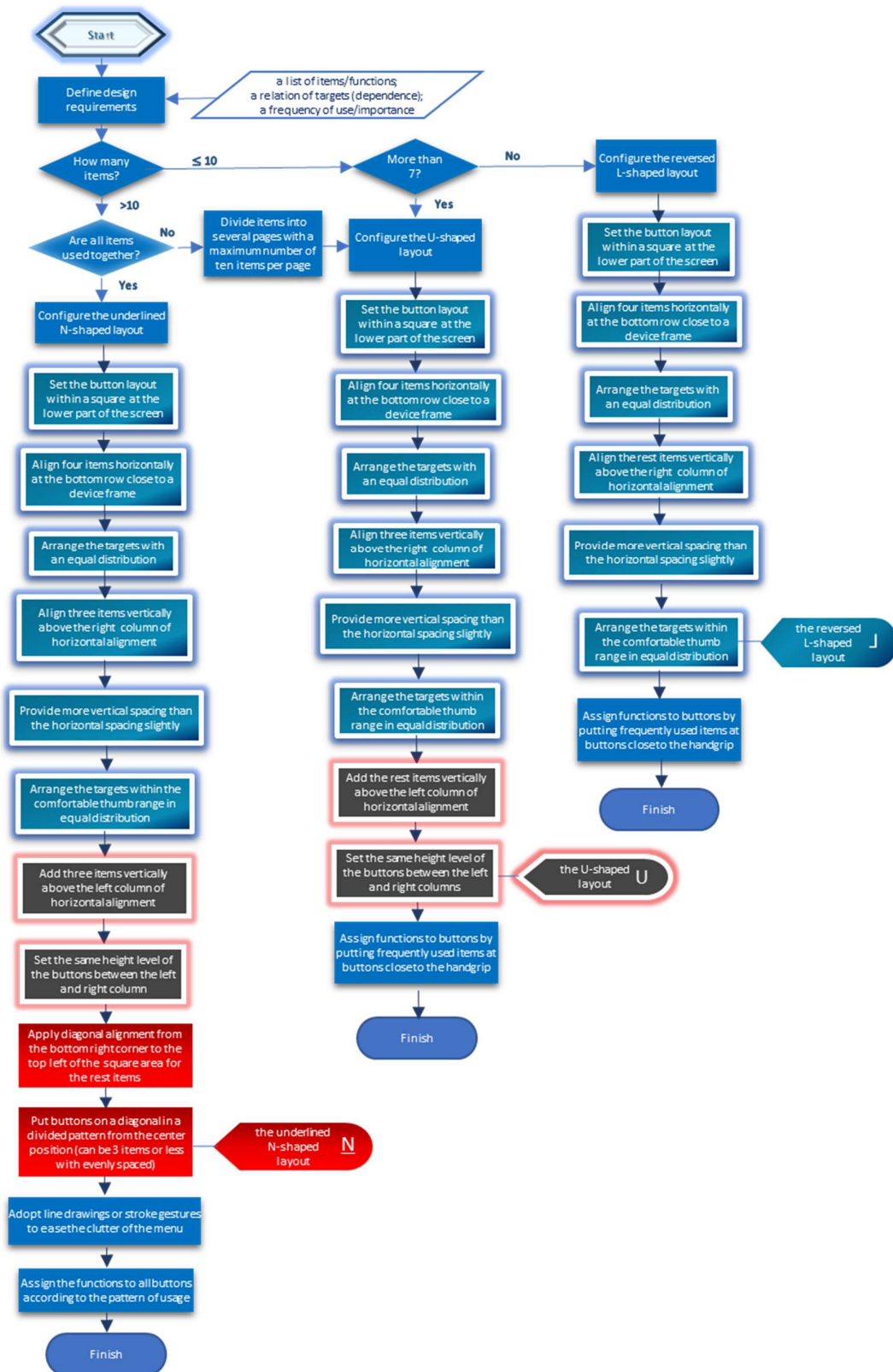

Figure 7.19 The updated flowchart based on expert feedback

7.6 Summary

In this chapter, the effectiveness of the eyes-free interface design framework and design guidelines is demonstrated in the experiment that evaluates the eyes-free interfaces for applications on a touchscreen. In addition, the experienced user interface designers provided feedback on the flowchart as well as the importance and potential effectiveness of the principles of spatial memory and proprioception in the interviews.

These provide insights into the usability and practicality of the design framework and process flowchart for the eyes-free interface. The design framework of eyes-free interfaces is applicable. The new formats of layouts provide better performance accuracy as opposed to the conventional format. Insights gained regarding the eyes-free interface design including practical suggestions about the proper number of buttons. The increased target size and spacing size will play a huge role to create better tolerance between users' recognition and accuracy.

Chapter 8 Summary and conclusions

This chapter provides a summary of the research on effective interface configurations for touchscreen eyes-free interaction. This research aims to enhance the understanding of human proprioception and spatial memory in order to deliver a framework and guidelines that can support effective eyes-free interface configurations of touchscreen surfaces. Since the interface configurations can be learned and memorized, spatial memory can be constructed implicitly. On the other hand, proprioception, another innate human ability, can facilitate controlling a hand and a finger pointing at the target accurately in the absence of vision. Touchscreen interaction under eyes-free interfaces takes advantage of these human abilities. The eyes-free interfaces afford users in controlling touchscreen devices dexterously and accurately under less visual demand. The studies in the thesis were conducted so as to examine how well the participants could perceive, learn, remember, and interact with eyes-free interfaces. The design framework and design guidelines proposed were based on the experimental outcomes caused by spatial memory and proprioception. The chapter starts with an overview of the research in order to provide an overall research journey. The research contributions are provided to specify outcomes adding to existing knowledge. Then, the limitations, and future works were stated. Lastly, concluding remarks were addressed.

8.1 Overview of the research

With the flat and featureless touchscreens, currently available smartphone interfaces do not offer many cues for efficient and safe eye-free interaction. This research concerns understanding human factors so as to assist in the improvement of the interface design for a better user experience. Currently, there are interaction and interface designs that have taken advantage of human abilities, either spatial memory like Imaginary Phone or proprioception like PocketThumb. In a more effective way, this research exploited the interaction effect of spatial memory and proprioception making touchscreen eyes-free interaction viable. As a result, users could interact with the touchscreen effectively without visual attention to the finger or the screen. The design of visual stimuli of the interface could strengthen user spatial memory and proprioception. Thus, the spatial positions of the interface should be configured to be easy to learn and remember as well as easy to reach and navigate.

Under this motivation and research gap, the research aim and objectives were set clearly in Chapter 1. After the literature review, the research approach or the research processes were determined in Chapter 3 to fulfill the research objectives. The research was carried out to answer four research questions (4 RQs). To explore the influencing factors in touchscreen

eyes-free interaction (RQ1), the literature review (Chapter 2) was undertaken initially to enhance the understanding of human cognitive abilities focusing on spatial memory and proprioception as well as the physiology of the human fingers, the interface and interaction design. In addition, to examine the characteristics of interface promoting dexterous operation (RQ2), the preliminary study was taken up in Chapter 4. The primary phase of the research started with the experimental prototype development of eyes-free interfaces. A comprehensive analysis of the previous findings brought about setting out the design requirements and key design parameters of eyes-free interface configurations. Then, the responsive web application was developed for the proof-of-concept implementation of eyes-free interfaces in experimental studies on spatial memory and proprioception. As a result, all experimental apparatuses were designed in Chapter 5. Two experimental studies on spatial memory and proprioception were conducted in Chapter 6 aimed to seek interface configurations that offer better performance accuracy in touchscreen eyes-free interaction (RQ3), to enhance understanding of proprioception and spatial memory toward interface configuration prototypes, and to develop the theoretical framework and practical guidelines for configuring the eyes-free interfaces. After that, the prototypes of eyes-free interfaces for applications on a touchscreen were proposed. The usability study and the expert interview were carried out in Chapter 7 to validate the design guidelines supporting the practitioner in designing eye-free interfaces to attain high accuracy and efficiency (RQ4) in the final stage. Figure 8.1 illustrates the key research outcomes in relation to the research questions.

This interface configuration study is focused so as to support operating touchscreen devices efficiently in eyes-free mode. This research deals with the experimental investigation for improving the input interface design from a user-centred perspective. The design goal involves creating practical interface configurations which lessen the physical effort and cognitive errors. This research delivered the conceptual framework of effective interface characteristics for eyes-free touchscreen interaction. It is expected that the design framework and design guidelines proposed could be applied to common design problems to facilitate users' multitasking to interact with touchscreen devices for non-visual attention.

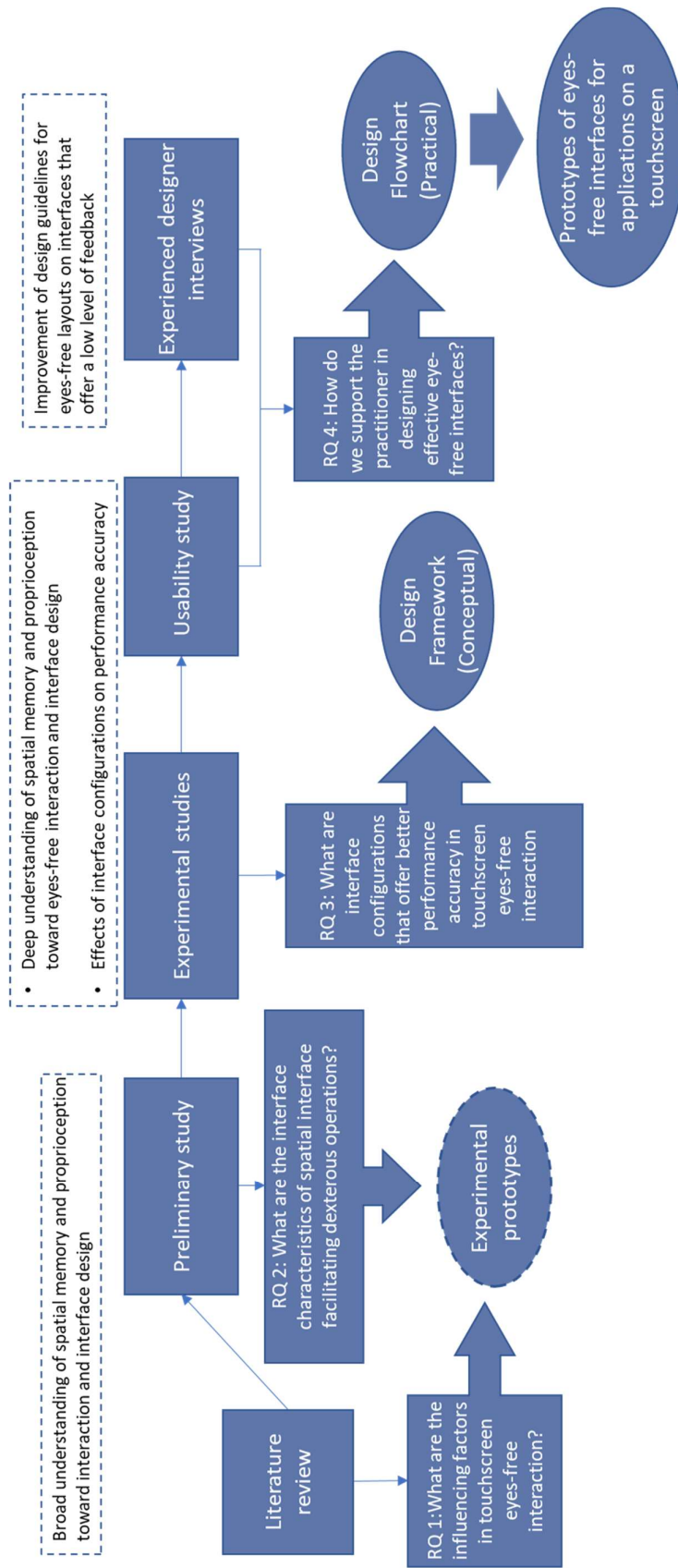

Figure 8. 1 Summary of the work

8.2 Research contributions

The contributions of this research refer to three knowledge types that are know-what, know-why, and know-how as previously mentioned in Chapter 3. These are derived from literature reviews, experimental studies, and expert interviews. The 'know-what' knowledge involves a description of the characteristics of the spatial interface that suit dexterous and eyes-free interaction and the understanding of the phenomenon that occurs during eyes-free interaction, caused by spatial memory and proprioception. The 'know-why' knowledge relates to the rationale behind the characteristics of interfaces in the proposed design framework and designed application prototypes. The 'know-how' knowledge is practical knowledge for designing effective eyes-free interface configurations presented in design guidelines. The main (M) and secondary (S) contributions from the research are presented in order of research processes as follows:

(1) Characteristics of spatial interface facilitating dexterous operations (S)

The preliminary study in Chapter 4 provided a broad understanding of spatial memory and proprioception as well as basic insights into the interface and interaction design. The characteristics of spatial interfaces facilitating dexterous operation were acquired. The interface that is fixed to a stationary device like a keyboard required lower mental and physical demands than the interface that is able to be moved such as a jigsaw. In dexterous operations, the interface configuration should be designed to lower cognitive load, facilitate user recognition, and support micro-interaction, so it was suggested to apply the fixed spatial interface. Under the fixed interface, users could learn and memorise its configuration or build up spatial memory unconsciously, and additionally, their hands and fingers would be anchored in a fixed position, so as to navigate and control the movement accurately and dexterously under proprioceptive sense. The target size and proximity between interface elements should be appropriate and adequate as well. That is the design should come up with the appropriate configuration involving area, target size and spacing. Considering the interaction design, the sequence or workflow between interface elements should be smooth to lessen cognitive errors and physical effort. This suggested that the fixed interface can be beneficial to spatial memory and proprioception for effective interaction.

(2) Understanding of spatial memory and proprioception toward eyes-free interaction and interface design (M)

Eyes-free interaction on the touchscreen interface is applicable under the fixed interface. Eye-free interaction schema on a touchscreen mobile was proposed in Chapter 5. The interface layout designed has an immediate impact on the user's spatial memory. A person can perceive,

learn interface configurations, and construct spatial memory implicitly. The information retrieved from spatial memory informs about the target position and contributes to motor planning and postural set. Accurate movement requires the coordination of spatial memory (mind) and the sensorimotor system (body) in relation to the objects and the body's position under proprioceptive processes (allocentric and egocentric frames of reference). The three experimental studies, including the two exploratory studies and the confirmative study, deepened the understanding of spatial memory and proprioception. The results of the experiments showed that the participants were able to learn positions and spatial relations among buttons within a reference frame in a short time. Despite their having limited time in constructing mental imagery of spatial interface, they could use this spatial understanding to map the position and to interact on a touchscreen appropriately. This suggests that the eyes-free interaction design is viable from product affordance (interface layout) and innate human abilities.

(3) Effects of different interface configurations on performance accuracy, as well as developed design framework of eyes-free interface (M)

These are the main contributions of the research. The effects of interface configurations on performance accuracy, caused by spatial memory and proprioception, were examined exhaustively in Chapter 6. The performance accuracy of eyes-free interaction was directly influenced by the interface configurations. In other words, spatial memory and proprioception were improved by designing an effective interface. The orientation of the layout determines the direction of thumb movement. The layouts where buttons align along thumb flexion direction, such as the horizontal, vertical right, and diagonal layouts were superior to the curved layouts that required a sideways movement of the thumb. In addition, the layouts in the square, provide the maximum line of symmetry. Therefore, this could enhance human cognition, and result in better proprioception. The structure layouts that aligned each button with even spacing offered good performance accuracy as the spatial discrimination would be consistent. The horizontal alignment provided the lowest mean distance error because of the vertical symmetrical pattern enhancing spatial memory and the proximity to the three sides of the device frame guiding the movement, so the horizontal layout should be the first priority when designing eyes-free interfaces. The layouts where buttons were aligned close to the device reference frame and handgrip provided better performance accuracy. As a result, the vertical-right alignment was preferable to the vertical-left alignment for right-handed thumb interaction. Furthermore, the presentation of the related objects in a single frame facilitates perception and spatial memory, the unified layout was, therefore, a suggested feature. Moreover, the middle position could be used as a reference to other buttons to facilitate both

spatial memory and proprioception in the spatial discrimination process. Therefore, the middle segmentation feature of interface configuration was further suggested in designing eyes-free interfaces. The interpretation that was made of this resulted in the development of the theoretical framework of eyes-free interface configurations. Spatial memory and proprioception could be strengthened with interface configurations in horizontal alignment and in structure with evenly spaced buttons within a unified layout, exploiting middle segmentation, in proximity to the device frame within a comfortable thumb range in a square symmetry, and along the thumb flexion axis. The design framework presented these characteristics of an eyes-free interface that supports non-visual touch screen interaction.

(4) Design guidelines for eyes-free layouts on interfaces that offer a low level of feedback (M)

The design guidelines contribute to the practical knowledge of this research. The procedural knowledge or formal processes of configuring an eyes-free interface, developed from the previous proposed conceptual framework, were illustrated in Chapter 7. In other words, the design guidelines were developed in practice to support the practitioner to design eyes-free interfaces so as to attain high accuracy and efficiency. The process flowchart was used to illustrate design guidelines step-by-step. Several aspects of design characteristics that enhance spatial memory and proprioception were combined in the layout design under this process flowchart. To sum up, the layouts should be configured for the ease of learning and navigating in the square area on the lower part of the touchscreen mobile, the handgrip position of most users. The number of interface elements would be a determining factor for the layout shape. If the number of interface elements was less than 5 buttons, the suggested alignment was horizontal, otherwise, the outputs were the structure unified layouts in the reversed L-shape for the interface with 5 to 7 buttons, the U-shape for the interface with 8 to 10 buttons, or the underlined N-shape for the interface with 11 to 13 buttons. All the layouts proposed were connected to the anchor point of proprioception, the place of the thumb knuckle at the bottom right corner of the screen. Moreover, the layouts could offer the symmetry feature and the motion along the thumb flexion direction. That the alignments close and parallel to the screen frame enhanced the accurate movement (proprioception). Ultimately, the divided pattern or middle segmentation feature was suggested in the diagonal alignment in the underlined N-shaped layout because the center point of the square having the diagonal symmetric property help to facilitate spatial memory and proprioception.

(5) Prototypes of eyes-free interfaces for applications on a touchscreen (S)

Prototypes of eyes-free interfaces for applications on a touchscreen were proposed for the shortcut menu in Chapter 7. These novel interface configurations followed the previously developed design guidelines. The home screen menu appeared in the U-shape instead of the 5x2 grid pattern. The arrow control menu was presented in the reversed L-shape layout instead of the conventional layout in plus-shape and the calculator layout appeared in the underlined N-shape instead of the 5x4 grid pattern. These layouts were proved to provide a good outcome in practical application and were ready to be used and applied. These layouts were in a unified frame and all configurations represented symmetrical properties, reinforcing spatial memory. The buttons in these layouts were aligned close to the reference frame of the device edges, and thumb anchor point. Moreover, they were put along the thumb flexion direction with even spacing facilitating the spatial discrimination process (proprioception) of users under eyes-free interaction. For these reasons, all layouts proposed were evaluated as usable and effective layouts.

Although this research was examined for the touchscreen mobile and for one-handed thumb interaction, this is not to say that research findings could not be applied in other contexts. The understandings of human spatial memory and proprioception are transferable knowledge. Thus, the theoretical framework of interface configuration design, supporting effective eyes-free interaction might be adopted to other interfaces with low feedback surfaces or different contexts of use. The next section provides the research limitation and future direction.

8.3 Limitations and future works

The studies in this research had some limitations, which in turn offered several opportunities for future works.

The studies provided only fundamental insights into interface configurations. Due to the data sets coming from the diverse devices from the participants' mobiles, in this research, the common coordinate system and the value in the relative unit were used for analysis to make the data comparable among the participants without referencing the actual distance (mm) but referencing to the 90 units common square area instead. Thus, the study about the optimisation of button size, button proximity, and threshold level should be further researched in a controlled factor of one specific mobile model.

There might be some extraneous variables related to the participants' behaviours that were uncontrollable, such as unintentional glances and mobile holding posture in spite of the fact that the participants were kept under close supervision. Moreover, the finger posture and ergonomics features could not be examined for in-depth analysis from the experimental setup online.

Since the experimental results derived from the three studies in the thesis solely occurred to the right-handed participants, it would be better to study more on left-handed users in order to validate the findings and design guidelines supporting for both right-handed and left-handed people. Moreover, the research participants were of young adult age and technology-minded people. Thus, it might be better to further research for other character traits to generalise the findings.

In this research, the design guidelines suggested three interface configurations and the maximum number of buttons can be 13 items or less under the interactions in the sitting condition for a one-handed thumb posture. This suggestion might be changed for interactions with other fingers like the index finger, or other setting conditions such as standing, walking, or multitasking because the hand's degree of freedom changed. In future research, more consideration needs to be included around the movement of the hand and the fingers' range to improve the understanding of eyes-free interface design and to make the proposed design framework more robust.

In today's world, lots of things are happening at the same time, and people could face multitasking. Suppose you are driving on the highway but are in urgent need of mobile access to the application. In this situation, you could use only the dominant hand to control the device while another hand is needed to steer the car, simultaneously, you need to pay visual attention to the road. The shortcut menu of eyes-free interfaces could be a solution in this scenario soon. In addition, cars now increasingly have touchscreens on the dashboard instead of physical button interfaces. User interface design patterns for infotainment systems aim to reduce the interaction time, drivers' mental workload in performing secondary task on the touchscreen, contributing to driver distraction reduction (Alarcón et al., 2022). Therefore, the study on dashboard touchscreen interfaces is suggested further for future projects because the comprehension of spatial memory and proprioception would help in designing effective interfaces for controlling touchscreen devices for an efficient and safe interaction in eyes-free mode. As previously mentioned, virtual reality headset like the HTC Vive Flow has recently adopted a phone controller interface. However, users still need to receive visual augmented feedback, and few interface elements or interaction vocabulary are available in this interactive system. Appropriate user interface design for mobile and touchscreen devices might be beneficial to people with visual impairment or in the phenomenon of situationally-induced impairment and disabilities as well (Palani et al., 2020; Senjam, 2021). In conclusion, a smartphone controller and car dashboard interface are gaining momentum for future work, and this is worth exploring further on eyes-free interface configuration design.

8.4 Concluding remarks

In this research, the exploration of a new category of the touchscreen interface is described. Despite the flat and featureless surface, simplifying and optimising menu layout patterns of touchscreen interface, make it possible for eyes-free interaction under single-handed thumb use to be achieved. This opens up a range of possibilities for peripheral touchscreen control such as TV remote controls and phone controller interfaces. Human-centred design thinking is important for interface design. The understanding of human spatial memory and proprioception would help practitioners design effective interfaces. Therefore, the three experiments were conducted so as to understand how to locate and memorise active touch points as well as the effect of interface configurations on performance accuracy. The conclusions are described how the interface configurations affect visual perception and spatial integration, providing insight into spatial memory and proprioception. The interface design characteristics to support the eyes-free interaction were presented in the design framework. This has yielded promising findings, as according to the experimental results, the design of interface configurations that follows the proposed framework and guidelines provides a positive effect on accuracy.

In summary, the design framework and design guidelines proposed in this thesis allow better interaction with smartphones either in eyes-free or eyes-on mode. Findings from this thesis are expected to serve as a ground for later research on novel effective touchscreen interface design that is of practical use to people to increase the accessibility of touchscreen interfaces. Many more works are required and pursued in the investigation into other touchscreen devices and interface configuration in interactions with other fingers, considering for the movement of the hand and the fingers' range, and practicalities of interface applications in various contexts to accomplish a change in interface configuration for eyes-free interaction. Therefore, in the near future under further research and ongoing development with user interface developers, smartphones could possibly be revolutionised into universal controller devices for eyes-free peripheral interaction. The eyes-free interface could be considered to have great potential for future designs and/or experiences, since the user's attention is not inhibited, the user could seamlessly interact with the touchscreen under multitasking.

References

- Abascal, J. (2018). Learning from Errors Designing Assistive Technology. In *Computer-Human Interaction Research and Applications*. Springer, Cham, 25-40.
- Alarcón, J., Balcázar, I., Collazos, C. A., Luna, H., & Moreira, F. (2022). User interface design patterns for infotainment systems based on driver distraction: A Colombian case study. *Sustainability*, 14(13), 8186.
- Andersen, E., Kozine, I., & Maier, A. (2019). Biased Decision-Making in Realistic Extra-Procedural Nuclear Control Room Scenarios. In *Design Computing and Cognition '18*. Cham: Springer International Publishing, 555-573.
- Andersen, E., Goucher-Lambert, K., Cagan, J., & Maier, A. (2021). Attention affordances: Applying attention theory to the design of complex visual interfaces. *Journal of Experimental Psychology. Applied*, 27(2), 338-351.
- Andreyev, S. (2012). Fixed Interfaces, Adaptive Interfaces... What is next? Total movability- a new paradigm for the user interface. arXiv preprint arXiv:1208.0408.
- Bachynskyi, M., Palmas, G., Oulasvirta, A., Steimle, J., & Weinkauff, T. (2015). Performance and Ergonomics of Touch Surfaces : A Comparative Study Using Biomechanical Simulation. *Proceedings of the 33rd Annual ACM Conference on Human Factors in Computing Systems*, 2015, 1817-1826.
- Bailey, R. W. (1982). *Human performance engineering: A guide for system designers*. Prentice Hall Professional Technical Reference.
- Bakker, S. (2013). Design for peripheral interaction. Eindhoven University of Technology, 184. <https://doi.org/10.6100/IR754544>
- Bakker, S., Hausen, D., & Selker, T. (2016). *Peripheral interaction : Challenges and opportunities for HCI in the periphery of attention*. (1st ed.), Human-computer interaction series.
- Behnke, R. (2006). *Kinetic anatomy* (2nd ed.). Champaign, IL: Human Kinetics.
- Bergstrom-Lehtovirta, J., & Oulasvirta, A. (2014). Modeling the functional area of the thumb on mobile touchscreen surfaces. *Proceedings of the SIGCHI Conference on Human Factors in Computing Systems*, 1991-2000.

- Berni, A., Maccioni, L., & Borgianni, Y. (2020). An eye-tracking supported investigation into the role of forms of representation on design evaluations and affordances of original product features. *Proceedings of the Design Society: DESIGN Conference*, 1, 1607-1616.
- Berthoz, A. (2000). *The brain's sense of movement (Perspectives in cognitive neuroscience)*. Cambridge, Mass.: Harvard University Press.
- Blessing, L. T., Chakrabarti, A. M. A. R. E. S. H., & Wallace, K. M. (1998). An overview of descriptive studies in relation to a general design research methodology. *Designers*, 42-56.
- Boring, S., Ledo, D., Chen, X., Marquardt, N., Tang, A., & Greenberg, S. (2012). The fat thumb. *Proceedings of the 14th International Conference on Human-computer Interaction with Mobile Devices and Services*, 39-48.
- Cash, P., Stanković, T., & Štorga, M. (2016). *Experimental design research : Approaches, perspectives, applications*. Cham: Springer International Publishing.
- Cattaneo, Z., Fantino, M., Silvanto, J., Tinti, C., Pascual-Leone, A., & Vecchi, T. (2010). Symmetry perception in the blind. *Acta psychologica*, 134(3), 398-402.
- Cerruti, G., Chablat, D., Gouaillier, D., & Sakka, S. (2015). Design method for an anthropomorphic hand able to gesture and grasp. In *2015 IEEE International Conference on Robotics and Automation (ICRA)*. IEEE, 3660-3667.
- Chakraborty, B. K., Sarma, D., Bhuyan, M. K., & MacDorman, K. F. (2018). Review of constraints on vision-based gesture recognition for human-computer interaction. *IET Computer Vision*, 12(1), 3-15.
- Chen, Q., & Yan, Z. (2016). Does multitasking with mobile phones affect learning? A review. *Computers in Human Behavior*, 54, 34-42.
- Choi, Y., Yang, X., Park, J., Lee, W., & You, H. (2020). Effects of smartphone size and hand size on grip posture in one-handed hard key operations. *Applied Sciences*, 10(23), 8374.
- Ciavola, B., & Gershenson, J. (2016). Affordance theory for engineering design. *Research in Engineering Design*, 27(3), 251-263.
- Cohen, L., Manion, L., & Morrison, K. (2007). *Research Methods in Education [internet resource] (6th ed.)*.

- Creswell, J. (2015). A concise introduction to mixed methods research. Sage mixed methods research series.
- Crilly, N., Moultrie, J., & Clarkson, P. (2004). Seeing things: Consumer response to the visual domain in product design. *Design Studies*, 25(6), 547-577.
- Crowe, A., Keessen, W., Kuus, W., Van Vliet, R., & Zegeling, A. (1987). Proprioceptive accuracy in two dimensions. *Perceptual and motor skills*, 64(3), 831-846.
- Csikszentmihalyi, M. (1997). *Finding flow: the psychology of engagement with everyday life*, Basic Books, New York.
- Curran, P. J., West, S. G., & Finch, J. F. (1996). The robustness of test statistics to nonnormality and specification error in confirmatory factor analysis. *Psychological methods*, 1(1), 16.
- Design Council UK (2013). The 5 key principles missing from Design & Technology education. Retrieved 21st October 2021, from <https://www.designcouncil.org.uk/our-work/news-opinion/the-5-key-principles-missing-from-design-technology-education/>
- Dezfuli, N., Khalilbeigi, M., Huber, J., Müller, F., & Mühlhäuser, M. (2012). PalmRC: Imaginary Palm-based Remote Control for Eyes-free Television Interaction. *Proceedings of the 10th European Conference on Interactive Tv and Video*, 27-34.
- Dobbelstein, D., Winkler, C., Haas, G., & Rukzio, E. (2017). PocketThumb: A wearable dual-sided touch interface for cursor-based control of smart-eyewear. *Proceedings of the ACM on Interactive, Mobile, Wearable and Ubiquitous Technologies*, 1(2), 1-17.
- Dragicevic P., Jansen Y., & Vande Moere A. (2021). Data Physicalization. In: Vanderdonckt J., Palanque P., Winckler M. (eds) *Handbook of Human Computer Interaction*. Springer, Cham. https://doi-org.proxy.lib.strath.ac.uk/10.1007/978-3-319-27648-9_94-1
- Dudchenko, P. (2010). *Why people get lost : The psychology and neuroscience of spatial cognition*. New York: Oxford University Press.
- Earles, J., Kersten, A., Berlin Mas, B., & Miccio, D. (2004). Aging and Memory for Self-Performed Tasks: Effects of Task Difficulty and Time Pressure. *The Journals of Gerontology. Series B, Psychological Sciences and Social Sciences*, 59(6), 285-293.

- Easterby-Smith, M., Thorpe, R., & Jackson, P. (2012). *Management research*. (4th ed.) London: SAGE.
- Ehrlich, K. (1996). Applied mental models in human-computer interaction. In: Johnson-Laird, P.N., Oakhill, J. & Garnham, A. (Eds.), *Mental models in cognitive science*, Psychology Press, East Sussex, 223-245.
- Eichenbaum, H. (2002). *The cognitive neuroscience of memory : An introduction*. Oxford ; New York: Oxford University Press.
- Feng, Y. & Agosto, D.E. (2017). The experience of mobile information overload: struggling between needs and constraints. *Information Research*, 22(2), paper 754. Retrieved from <http://InformationR.net/ir/22-2/paper754.html>
- Fuentes, C. T., & Bastian, A. J. (2010). Where is your arm? Variations in proprioception across space and tasks. *Journal of neurophysiology*, 103(1), 164-171.
- Gilliot, J., Casiez, G., & Roussel, N. (2014). Impact of form factors and input conditions on absolute indirect-touch pointing tasks. In *Proceedings of the SIGCHI Conference on Human Factors in Computing Systems*, 723-732.
- Gray, D. (2014). *Doing research in the real world* (3rd ed.). London: SAGE.
- Groh, J. M. (2014). *Making space: how the brain knows where things are*. Harvard University Press.
- Gustafson, S., Bierwirth, D., & Baudisch, P. (2010). Imaginary interfaces: spatial interaction with empty hands and without visual feedback. In *Proceedings of the 23rd annual ACM symposium on User interface software and technology*, 3-12.
- Gustafson, S., Holz, C., & Baudisch, P. (2011). Imaginary phone. *Proceedings of the 24th Annual ACM Symposium on User Interface Software and Technology*, 283-292.
- Gustafson, S. G., Rabe, B., & Baudisch, P. M. (2013). Understanding palm-based imaginary interfaces: the role of visual and tactile cues when browsing. In *Proceedings of the SIGCHI Conference on Human Factors in Computing Systems*, 889-898.
- Hegarty, M. (2011). The cognitive science of visual-spatial displays: Implications for design. *Topics in cognitive science*, 3(3), 446-474.
- Hellier, J. (2016). *The Five Senses and Beyond*. Westport: ABC-CLIO, LLC.

- Henry, P. (1998). *User-centered information design for improved software usability* (Artech House computer science library). Boston: Artech House.
- Henze, N., Rukzio, E., & Boll, S. (2011). 100,000,000 taps: Analysis and Improvement of Touch Performance in the Large. *Proceedings of the 13th International Conference on Human Computer Interaction with Mobile Devices and Services*, 133-142.
- Hillier, S., Immink, M., & Thewlis, D. (2015). Assessing Proprioception. *Neurorehabilitation and Neural Repair*, 29(10), 933-949.
- Hinton, P. (2004). *Statistics explained* (2nd ed.). London ; New York: Routledge.
- Hoover, S., Berkman, E. (2011). *Designing mobile interfaces* (1st ed.). Sebastopol, CA: O'Reilly.
- Huang, D.Y., Chan, L., Yang, S., Wang, F., Liang, R.H., Yang, D.N., Hung, Y.P., & Chen, B.Y. (2016). Digitspace: Designing thumb-to-fingers touch interfaces for one-handed and eyes-free interactions. In *Proceedings of the 2016 CHI Conference on Human Factors in Computing Systems*, 1526-1537.
- Hughes, L. E., & Babski-Reeves, K. (2005). Time pressure and mental workload effects on perceived workload and key strike force during typing. In *Proceedings of the Human Factors and Ergonomics Society Annual Meeting*. Sage CA: Los Angeles, CA: SAGE Publications, 49(14), 1390-1394.
- Humphreys, G., Duncan, J., Treisman, A., Royal Society, & Novartis Foundation for Gerontological Research. (1999). *Attention, space, and action: Studies in cognitive neuroscience*. Oxford; New York: Oxford University Press.
- Illera, C., Fink, M., Hinneberg, H., Kath, K., Waldau, N., Rosič, A., & Wurzer, G. (2010). NO_PANIC. "Escape and panic in buildings"—architectural basic research in the context of security and safety research. In *Pedestrian and Evacuation Dynamics 2008*. Springer, Berlin, Heidelberg, 733-742.
- Jetter, H. C., Leifert, S., Gerken, J., Schubert, S., & Reiterer, H. (2012). Does (multi-) touch aid users' spatial memory and navigation in 'panning' and in 'zooming & panning' UIs? In *Proceedings of the International Working Conference on Advanced Visual Interfaces*, 83-90.

- Jin, Z. X., Plocher, T., & Kiff, L. (2007). Touch screen user interfaces for older adults: button size and spacing. In *International Conference on Universal Access in Human-Computer Interaction*. Springer, Berlin, Heidelberg, 933-941.
- Johnson, J. (2020). *Designing with the mind in mind: simple guide to understanding user interface design guidelines*. Morgan Kaufmann.
- Johnson, P., & Duberley, J. (2000). *Understanding management research : An introduction to epistemology*. London: SAGE.
- Jones, L., & Lederman, S. (2006). *Human hand function*. Oxford: Oxford University Press.
- Kajastila, R. (2013). *Interaction with eyes-free and gestural interfaces*. Aalto University: PhD Thesis.
- Kerr, A., & Rowe, P. (2019). *An introduction to human movement and biomechanics*. (7th ed.), *Physiotherapy essentials*.
- Kitchin, R., & Freundschuh, S. (2000). *Cognitive mapping : Past, present and future* (Routledge frontiers of cognitive science ; 4). London ; New York: Routledge.
- Le, H., Mayer, S., Bader, P., & Henze, N. (2018). Fingers' Range and Comfortable Area for One-Handed Smartphone Interaction Beyond the Touchscreen. *Proceedings of the 2018 CHI Conference on Human Factors in Computing Systems*, 1-12.
- Le, H. V., Mayer, S., Steuerlein, B., & Henze, N. (2019, October). Investigating unintended inputs for one-handed touch interaction beyond the touchscreen. In *Proceedings of the 21st International Conference on Human-Computer Interaction with Mobile Devices and Services*, 1-14.
- Lee, S., Cha, M., & Ji, Y. (2019). Investigating Smartphone Touch Area with One-Handed Interaction: Effects of Target Distance and Direction on Touch Behaviors. *International Journal of Human-computer Interaction*, 35(16), 1532-1543.
- Leitão, R., & Silva, P. A. (2012). Target and spacing sizes for smartphone user interfaces for older adults: design patterns based on an evaluation with users. 1-16.
- Leonard, C. (1998). *The neuroscience of human movement*. St. Louis: Mosby.
- Lephart, S., & Fu, F. (2000). *Proprioception and neuromuscular control in joint stability*. Champaign, IL: Human Kinetics.

- Li, Z. M., & Goitz, R. J. (2003). Biomechanical evaluation of the motor function of the thumb. *Technology and Health Care*, 11(4), 233-243.
- Lin, S., Su, C., Cheng, K., Liang, R., Kuo, T., & Chen, B. (2011). Pub - point upon body: exploring eyes-free interaction and methods on an arm. *Proceedings of the 24th Annual ACM Symposium on User Interface Software and Technology*, 481-488.
- Logie, R.H. (2011). The visual and the spatial of a multicomponent working memory. In André Vandierendonck and Arnaud Szmalec (eds.), *Spatial Working Memory*, East Sussex, Psychology Press, 31-57.
- Lorenz A., De Castro C., & Rukzio E. (2009). Using handheld devices for mobile interaction with displays in home environments. *Proceedings of the 11th International Conference on Human-computer Interaction with Mobile Devices and Services*, 1-10. <https://doi.org/10.1145/1613858.1613882>
- Lu, Y., Yu, C., Yi, X., Shi, Y., & Zhao, S. (2017). Blindtype: Eyes-free text entry on handheld touchpad by leveraging thumb's muscle memory. *Proceedings of ACM on Interactive, Mobile, Wearable and Ubiquitous Technologies*, 1(2), 1-24.
- MacKenzie, I. S. (1995). Movement time prediction in human-computer interfaces. In *Readings in human-computer interaction*. Morgan Kaufmann, 483-493.
- MacKenzie, I.S. (2012). *Human-computer interaction: An Empirical Research Perspective*. Burlington: Elsevier Science.
- Magill, R., & Anderson, D. (2017). *Motor learning and control: Concepts and applications (11th ed.)*, New York: McGraw-Hill Publishing.
- Maher, M. L., & Lee, L. (2017). Designing for gesture and tangible interaction. *Synthesis Lectures on Human-Centered Interaction*, 10(2), i-111.
- Mark, G. (2015). Multitasking in the digital age. *Synthesis Lectures on Human-Centered Informatics*, 8(3), 1-113.
- Mayer, S., Gad, P., Wolf, K., Woźniak, P.W., & Henze, N. (2017). Understanding the ergonomic constraints in designing for touch surfaces. In *Proceedings of the 19th International Conference on Human-Computer Interaction with Mobile Devices and Services (MobileHCI '17)*. Association for Computing Machinery, New York, NY, USA, Article 33, 1-9.

- Mayer, S., Le, H. V., & Henze, N. (2018). Designing finger orientation input for mobile touchscreens. In *Proceedings of the 20th International Conference on Human-Computer Interaction with Mobile Devices and Services*, 1-9.
- Mayer, S., Le, H. V., Funk, M., & Henze, N. (2019). Finding the sweet spot: Analyzing unrestricted touchscreen interaction in-the-wild. In *Proceedings of the 2019 ACM International Conference on Interactive Surfaces and Spaces*, 171-179.
- McKay, E. (2013). *UI Is Communication*. San Francisco: Elsevier Science & Technology.
- Medhi, I., Patnaik, S., Brunskill, E., Gautama, S., Thies, W., & Toyama, K. (2011). Designing mobile interfaces for novice and low-literacy users. *ACM Transactions on Computer-human Interaction*, 18(1), 1-28.
- Montgomery, D., & Runger, G. (2014). *Applied statistics and probability for engineers* (6th ed.). Hoboken, NJ: Wiley.
- Morris, A. (2015). *A practical introduction to in-depth interviewing*. SAGE.
- Morris, D., Saponas, T. S., & Tan, D. (2011). Emerging input technologies for always-available mobile interaction. *Foundations and Trends in Human-Computer Interaction*, 4(4), 245-316.
- Motamed, M. (2016). *Role of Visual Affordance of a Spatial Layout on Human Interactions at a Work Environment* (Doctoral dissertation, University of Minnesota).
- Müller, F., McManus, J., Günther, S., Schmitz, M., Mühlhäuser, M., & Funk, M. (2019). Mind the Tap. *Proceedings of the 2019 CHI Conference on Human Factors in Computing Systems*, 1-13.
- Nacenta, M. A., Kamber, Y., Qiang, Y., & Kristensson, P. O. (2013). Memorability of pre-designed and user-defined gesture sets. In *Proceedings of the SIGCHI Conference on Human Factors in Computing systems*, 1099-1108.
- Ng, A., Williamson, J., & Brewster, S. (2015). The Effects of Encumbrance and Mobility on Touch-Based Gesture Interactions for Mobile Phones. *Proceedings of the 17th International Conference on Human-computer Interaction with Mobile Devices and Services*, 536-546.
- NK, M., & Telles, S. (2004). Spatial and verbal memory test scores following yoga and fine arts camps for school children. *Indian J Physiol Pharmacol*, 48(3), 353-356.

- Norman, D.A. (1984). Stages and levels in human-machine interaction, *International Journal of Man-Machine Studies*, Vol. 21 No. 4, 365–375. [https://doi.org/10.1016/S0020-7373\(84\)80054-1](https://doi.org/10.1016/S0020-7373(84)80054-1)
- Norman, D., & Draper, S. (1986). *User centered system design : New perspectives on human-computer interaction*. Hillsdale, N.J.: L. Erlbaum Associates.
- Norros, L., Savioja, P., & Koskinen, H. (2015). *Core-task design: A practice-theory approach to human factors*. Morgan & Claypool. CA, USA. Synthesis digital library of engineering and computer science.
- Palani, H. P., Fink, P. D., & Giudice, N. A. (2020). Design guidelines for schematizing and rendering haptically perceivable graphical elements on touchscreen devices. *International Journal of Human–Computer Interaction*, 36(15), 1393-1414.
- Park, Y., & Han, S. (2010). One-handed thumb interaction of mobile devices from the input accuracy perspective. *International Journal of Industrial Ergonomics*, 40(6), 746-756.
- Parhi P., Karlson A., & Bederson B. (2006). Target size study for one-handed thumb use on small touchscreen devices. In *Proceedings of the 8th Conference on Human-computer Interaction with Mobile Devices and Services*, 159, 203-210.
- Peddie, J. (2017). *Augmented reality: Where we will all live*. Springer.
- Perry, K. B., & Hourcade, J. P. (2008). Evaluating one handed thumb tapping on mobile touchscreen devices. In *Proceedings of graphics interface 2008*, 57-64.
- Piebalga, A., & Yung, S. T. (Eds.). (2014). *Design directions: The relationship between humans and technology*. Cambridge Scholars Publishing.
- Pietroszek, K., & Lank, E. (2012). Clicking blindly: Using spatial correspondence to select targets in multi-device environments. In *Proceedings of the 14th international conference on Human-computer interaction with mobile devices and services*, 331-334.
- Poppinga, B., Sahami Shirazi, A., Henze, N., Heuten, W., & Boll, S. (2014). Understanding shortcut gestures on mobile touch devices. *Proceedings of the 16th International Conference on Human-computer Interaction with Mobile Devices & Services*, 173-182.
- Probst, K. (2016), Peripheral interaction in desktop computing: why it's worth stepping beyond traditional mouse and keyboard. In: Bakker, S. et al. (eds.), *Peripheral*

Interaction, Human-Computer Interaction Series, Springer, Switzerland, 183-205.
https://doi.org/10.1007/978-3-319-29523-7_9

Proctor, R. W., & Vu, K. P. L. (2006). The cognitive revolution at age 50: Has the promise of the human information-processing approach been fulfilled? *International Journal of Human-Computer Interaction*, 21(3), 253-284.
https://doi.org/10.1207/s15327590ijhc2103_1

Punchoojit, L., & Hongwarittorm, N. (2017). Usability Studies on Mobile User Interface Design Patterns: A Systematic Literature Review. *Advances in Human-computer Interaction*, 2017, 1-22.

Purves, D. (2013). *Principles of cognitive neuroscience* (2nd ed.). Sunderland, Mass.: Sinauer Associates.

Purves, D., & Williams, S. (2001). *Neuroscience* (2nd ed.). Sunderland, Mass.: Sinauer Associates.

Rama, M. (2001). *Technology generations handling complex user interfaces*. Technische Universiteit Eindhoven Proefschrift.

Rasmussen, J., & Vicente, K.J. (1989). Coping with human errors through system design: implications for ecological interface design. *International Journal of Man-Machine Studies*, Vol. 31 No. 5, 517-534. [https://doi.org/10.1016/0020-7373\(89\)90014-X](https://doi.org/10.1016/0020-7373(89)90014-X)

Richardson, J.T., & Vecchi, T. (2002). A jigsaw-puzzle imagery task for assessing active visuospatial processes in old and young people. *Behavior Research Methods, Instruments, & Computers: A Journal of the Psychonomic Society*, Vol. 34 No. 1, 69-82.

Ritter, F., Baxter, G., & Churchill, E. (2014). *Foundations for designing user-centered systems: What system designers need to know about people*. Springer-Verlag London, DOI, 10, 978-1.

Robelski, S., & Wischniewski, S. (2016). Scoping Review on Human-Machine Interaction and Health and Safety at Work. *HCI in Business, Government, and Organizations: Information Systems*, 9752, 337-347.

Rosenbaum, D. (2010). *Human motor control* (2nd ed.). Amsterdam; Boston, MA: Elsevier.

- Roudaut, A., Bailly, G., Lecolinet, E., & Nigay, L. (2009). Leaf menus: Linear menus with stroke shortcuts for small handheld devices. In IFIP Conference on Human-Computer Interaction. Springer, Berlin, Heidelberg, 616-619.
- Royer, F. L. (1981). Detection of symmetry. *Journal of Experimental Psychology: Human Perception and Performance*, 7(6), 1186–1210. <https://doi.org/10.1037/0096-1523.7.6.1186>
- Sam, A., Steinbrenner, J., Morgan, W., Chin, J., & AFIRM for Paras Team. (2019). Visual Cues. FPG Child Development Institute, University of North Carolina. Retrieved 21st October 2021, from <https://afirm.fpg.unc.edu/visual-cues-introduction-practice>
- Saunders, M., Lewis, P., & Thornhill, A. (2015). *Research Methods for Business Students*. Pearson Education UK.
- Sawyer, J. O., & Bennett, A. (2006). Comparing the level of dexterity offered by latex and nitrile SafeSkin gloves. *Annals of Occupational Hygiene*, 50(3), 289-296.
- Schade A. (2016) Customization vs. Personalization in the User Experience. Retrieved 21st October 2021, from <https://www.nngroup.com/articles/customization-personalization>
- Schoon, B. (2021). HTC's new Vive Flow VR headset uses your phone as a controller, and it requires Android. Retrieved 21st October 2021, from <https://9to5google.com/2021/10/14/htc-vive-flow-vr-headset-android>
- Senjam, S. S. (2021). The current advances in human–smartphone user interface design: An opportunity for people with vision loss. *Indian Journal of Ophthalmology*, 69(9), 2544.
- Shao, J., Xue, C., Wang, F., Wang, H., Tang, W., Chen, M., & Kang, M. (2015). Research of Digital Interface Layout Design based on Eye-tracking. *MATEC Web of Conferences*, 22, 1018.
- Shikhman, M. (2007). Age, gender, general intelligence and educational level influences on working memory. City University of New York.
- Silverman, D. (2021). *Doing qualitative research* (6th ed.).
- Six, J. M., & Macefield, R. (2016). *How to determine the right number of participants for usability studies*. San Francisco (CA): UXmatters.

- Smirni, P., Villardita, C., & Zappalá, G. (1983). Influence of different paths on spatial memory performance in the block-tapping test. *Journal of Clinical and Experimental Neuropsychology*, 5(4), 355-359.
- Sodiq Olamide, O. (2019). Smartphone “Aspect Ratio” — Meaning, Types, and Why You Shouldn’t Care. Retrieved 1st November 2020, from <https://www.dignited.com/31992/smartphone-aspect-ratio-meaning-types-and-why-you-shouldnt-care/>
- Soegaard, M. (2018). The basics of user experience design. Interaction design foundation.
- Steen, M. (2011). Tensions in human-centred design. *CoDesign*, 7(1), 45-60.
- Sutcliffe, A. (1988). Human-computer interface design. Basingstoke: Macmillan Education.
- Tao, D., Wang, T., Tan, H., Cai, J., & Zhang, X. (2019). Understanding One-Handed Thumb Interaction with a Mobile Touchscreen Device: Effects of Keyboard Size, Gap and Button Shape. In *International Conference on Applied Human Factors and Ergonomics*. Springer, Cham, 412-423.
- Thomas, J. (2010). *Spatial memory: Visuospatial processes, cognitive performance and developmental effects (Neuroscience research progress series)*. New York: Nova Science.
- Trudeau, M. B., Udtamadilok, T., Karlson, A. K., & Dennerlein, J. T. (2012). Thumb motor performance varies by movement orientation, direction, and device size during single-handed mobile phone use. *Human factors*, 54(1), 52-59.
- Tuthill, J., & Azim, E. (2018). Proprioception. *Current Biology*, 28(5), R194-R203.
- Tversky, B. (2002). Navigating by mind and by body. In *International Conference on Spatial Cognition*. Springer, Berlin, Heidelberg, 1-10.
- Umami, M. K., Arezes, P. M., & Sampaio, Á. M. (2016). Understanding finger postures when touching targets on the touchscreen of mobile devices. *Dyna*, 83(197), 31-37.
- UNCTAD (2021). *Technology and Innovation Report 2021: Catching technological waves: Innovation with equity*. United Nations publication, New York and Geneva.
- van Beers, R. J., Wolpert, D. M., & Haggard, P. (2002). When feeling is more important than seeing in sensorimotor adaptation. *Current biology*, 12(10), 834-837.

- Vandierendonck, A., & Szmalec, A. (Eds.). (2011). *Spatial Working Memory* (1st ed.). Psychology Press. <https://doi.org/10.4324/9781315793252>
- Vazquez-Alvarez, Y., & Brewster, S. A. (2011). Eyes-free multitasking: the effect of cognitive load on mobile spatial audio interfaces. In *Proceedings of the SIGCHI Conference on Human Factors in Computing Systems*, 2173-2176.
- Wallace, R. (1972). Spatial S-R compatibility effects involving kinesthetic cues. *Journal of Experimental Psychology*, 93(1), 163-168.
- Wang, F., & Ren, X. (2009). Empirical evaluation for finger input properties in multi-touch interaction. In *Proceedings of the SIGCHI Conference on Human Factors in Computing Systems*, 1063-1072.
- Weiss, S. (2002). *Handheld usability*. John Wiley & Sons.
- Winfield, I. (1986). *Human resources and computing*. London: Heinemann.
- Wickens, C. (2002). Multiple resources and performance prediction. *Theoretical Issues in Ergonomics Science*, 3(2), 159-177.
- Worringham, C. J., & Kerr, G. K. (2000). Proprioception and stimulus-response compatibility. *The Quarterly Journal of Experimental Psychology: Section A*, 53(1), 69-83.
- Wu, L., Zhu, Z., Cao, H., & Li, B. (2016). Influence of information overload on operator's user experience of human-machine interface in LED manufacturing systems, *Cognition, Technology & Work*, Vol. 18 No. 1, 161-173.
- Xu, W., Liu, J., Yu, C., & Shi, Y. (2012). Digging unintentional displacement for one-handed thumb use on touchscreen-based mobile devices. In *Proceedings of the 14th international conference on Human-computer interaction with mobile devices and services*, 261-270.
- Yi, B., Cao, X., Fjeld, M., & Zhao, S. (2012). Exploring User Motivations for Eyes-Free Interaction on Mobile Devices. *Proceedings of the SIGCHI Conference on human factors in computing systems*, 1(1), 2789-2792.
- Yoon, S. H., Huo, K., & Ramani, K. (2016). Wearable textile input device with multimodal sensing for eyes-free mobile interaction during daily activities. *Pervasive and Mobile Computing*, 33, 17-31.

Young, M.S., Brookhuis, K.A., Wickens, C.D., & Hancock, P.A. (2015). State of science: mental workload in ergonomics. *Ergonomics*, Vol. 58 No. 1, pp.1-17.
<https://doi.org/10.1080/00140139.2014.956151>

Zeidner, M. and Matthews, G. (2011). *Anxiety 101*, Springer Pub. Co, New York.

Zhao, S., Dragicevic, P., Chignell, M., Balakrishnan, R., & Baudisch, P. (2007). EarPod: eyes-free menu selection using touch input and reactive audio feedback. *Proceedings of the SIGCHI Conference on Human Factors in Computing Systems*, 1395-1404.

Appendices

Appendix 1 The mind map of the inspiration phase for eyes-free interaction

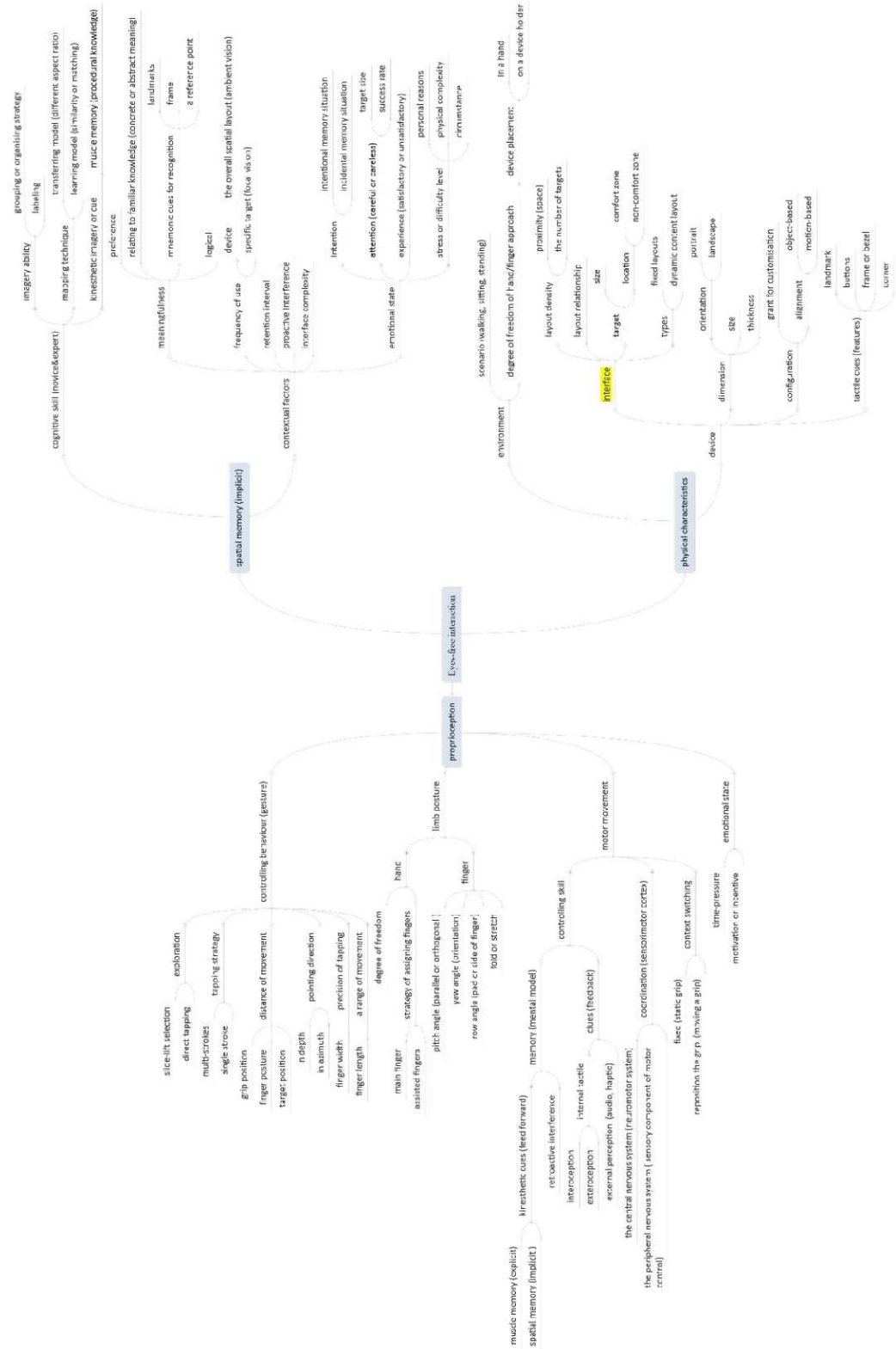

Mind map of eyes-free interaction

Appendix 2 The layouts for eyes-free interaction in the ideation phase

The layouts that are chosen for the pilot test

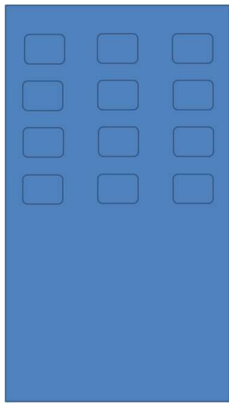

4x3 grid

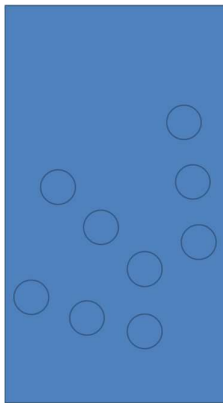

prong

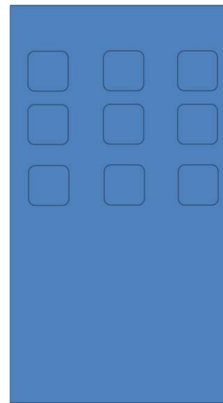

3x3 grid

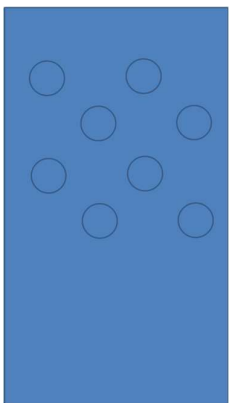

zigzag toward NW

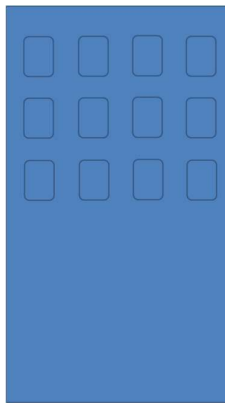

3x4 grid

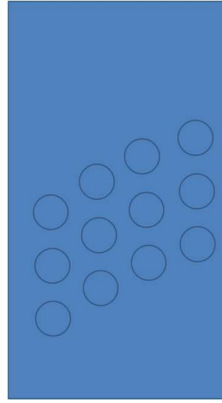

radial pattern

The layouts that are not chosen for the pilot test

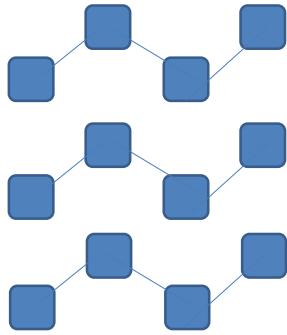

zigzag toward NE direction

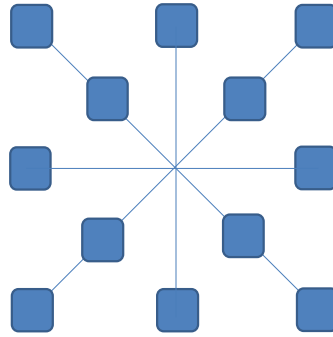

outward from the center

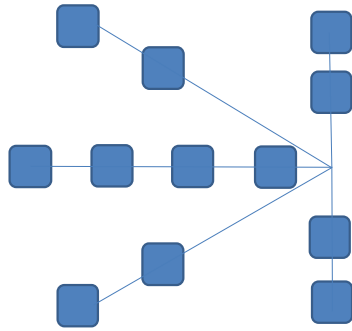

outward from the middle right

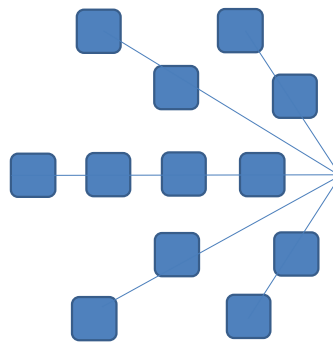
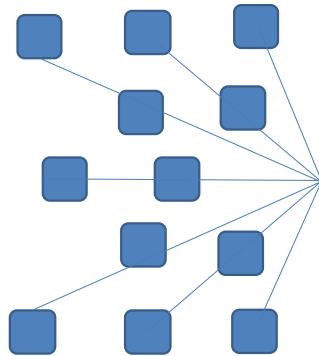

Appendix 3 Specification of experimental prototypes

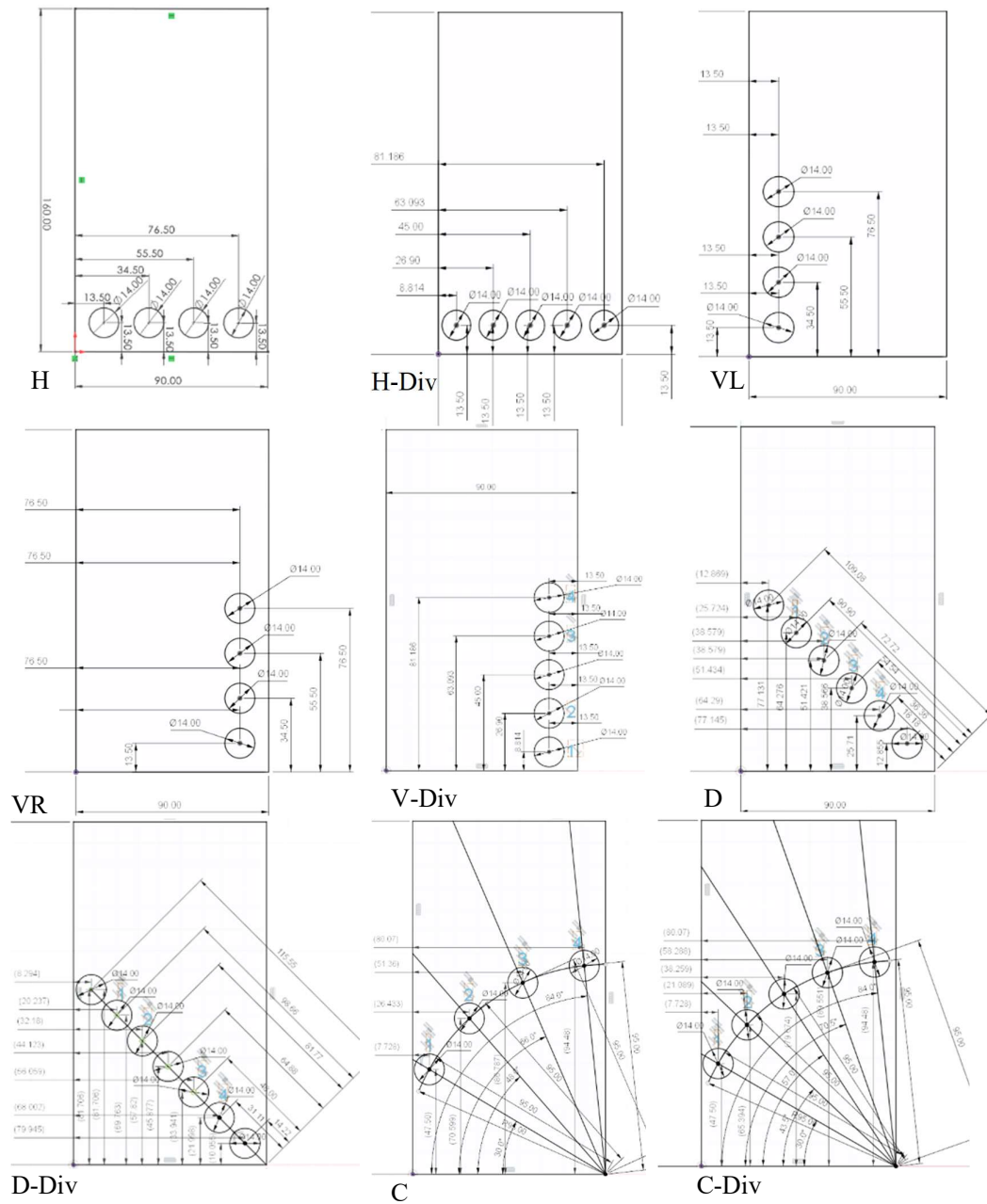

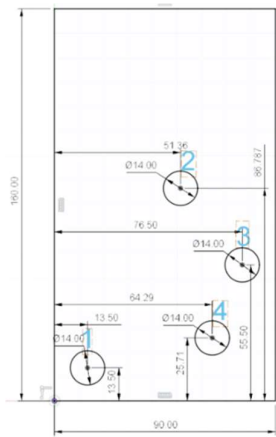

Un-1

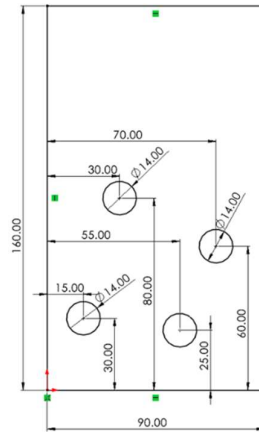

Un-2

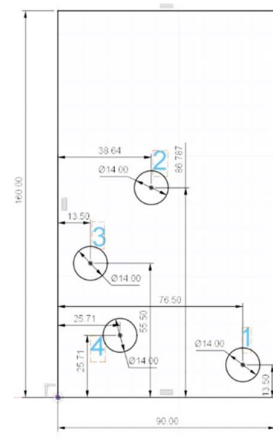

Un-1M

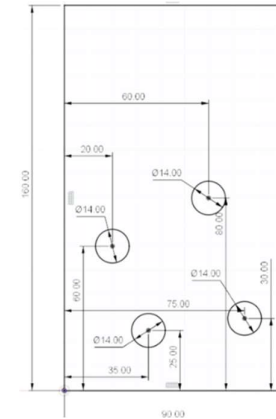

Un-2M

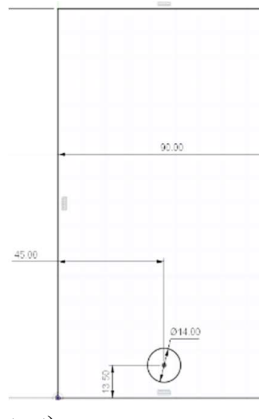

test)

a divided half-screen width (Pilot

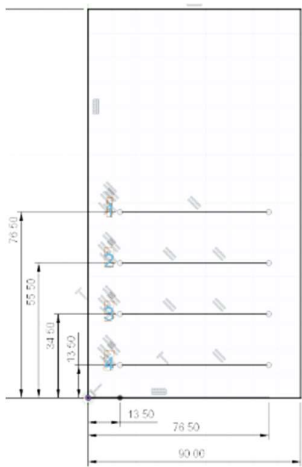

H-Line

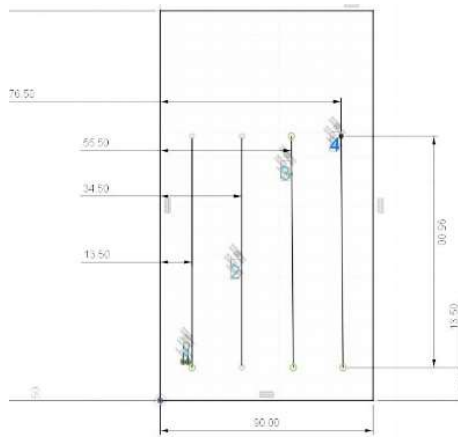

V-Line

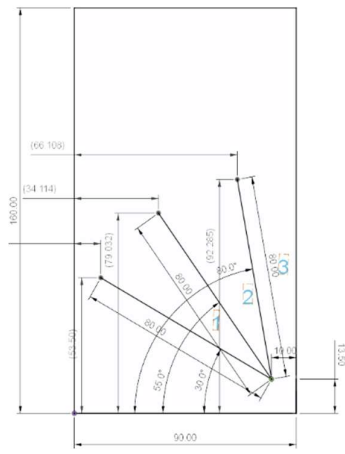

D-Line

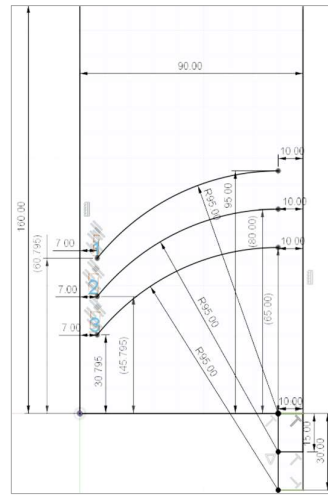

C-Line

Appendix 4 The processing method of the raw data

Data recorded from the screen-recording app including the touch coordinate, the screen width, and the screen height of the participant's mobile, was processed for the relative unit of the standard coordinate system (x^* , y^*) within the common square area of 90 units as the following example:

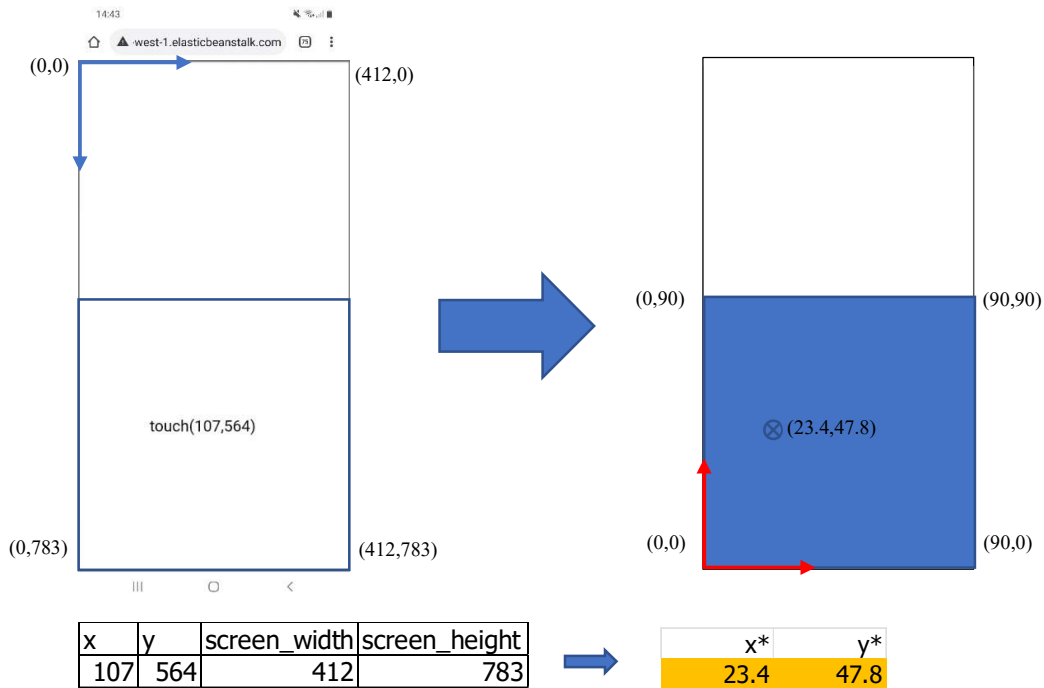

$$x^* = \frac{90 x}{\text{screen width}} = \frac{90 \times 107}{412} = 23.4 \quad y^* = \frac{90 (\text{screen height} - y)}{\text{screen width}} = \frac{90 \times (783 - 564)}{412} = 47.8$$

In the screen recording app, the top left corner would be the origin of the coordinate system. Providing that the origin of the touch coordinate is at the lower left corner, the calculation of y^ requires subtracting y from the screen height. As the square area depends on the screen width, the aspect ratio related to the proportion of screen height to the screen width would not use in the calculation and not affect the outcome data.*

Calculation of the mean distance error (d)

The displacement error was calculated as the Euclidean distance (the shortest distance to the target position) through the Pythagorean theorem.

The calculation of the mean distance error was shown in the following example.

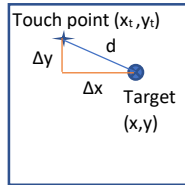

| x_t | y_t | x | y |
|-------|-------|------|------|
| 70.6 | 18.8 | 76.5 | 13.5 |

$$\Delta x^2 + \Delta y^2 = d^2$$

$$(76.5 - 70.6)^2 + (13.5 - 18.8)^2 = d^2$$

$$d = \sqrt{5.9^2 + 5.3^2} = 7.93$$

Appendix 5 Analysis method of the repeated measures ANOVA

The repeated measures ANOVA is used to determine whether or not there is a statistically significant difference between the means of three or more groups in which the same subjects show up in each group. It is the extension of the dependent t-test, processed by calculating the among group (treatment) variance and dividing this by the within group (error) variance in order to get the F ratio.

The summary table of ANOVA calculations provided by most statistical software packages.

| Source of variation | Sum of squares | df | Mean square | F ratio |
|---------------------|-------------------|--------------|-------------------|--------------------------------------|
| Conditions | $SS_{conditions}$ | $(k-1)$ | $MS_{conditions}$ | $\frac{MS_{conditions}}{MS_{error}}$ |
| Subjects | $SS_{subjects}$ | $(n-1)$ | $MS_{subjects}$ | $\frac{MS_{subjects}}{MS_{error}}$ |
| Error | SS_{error} | $(k-1)(n-1)$ | MS_{error} | |
| Total | SS_T | $(N-1)$ | | |

where N is the total number of data points, k is the number of conditions, n is the number of subjects per condition.

Calculate

$$SS_{conditions} = \sum_{i=1}^k n_i (\bar{x}_i - \bar{x})^2$$

where k = number of conditions, n_i = number of subjects under each (i^{th}) condition, Mean of i^{th} term = mean distance error for each (i^{th}) condition, Mean = grand mean.

n_i is the same for each iteration: it is the number of subjects in our design.

Within-groups variation (SS_w) is also calculated in the same way as in an independent ANOVA

$$SS_w = \sum_1 (x_{i1} - \bar{x}_1)^2 + \sum_2 (x_{i2} - \bar{x}_2)^2 + \dots + \sum_k (x_{ik} - \bar{x}_k)^2$$

where x_{i1} is the distance error of the i^{th} subject in group 1, x_{i2} is the distance error of the i^{th} subject in group 2, and x_{ik} is the distance error of the i^{th} subject in group k .

Calculate

$$SS_{subjects} = k \cdot \sum (\bar{x}_i - \bar{x})^2$$

where k = number of conditions, \bar{x}_i mean of subject i , and \bar{x} = grand mean.

$$SS_{error} = SS_w - SS_{subjects}$$

$$MS_{conditions} = \frac{SS_{conditions}}{(k-1)}$$

$$MS_{error} = \frac{SS_{error}}{(k-1)(n-1)}$$

$$F = \frac{MS_{conditions}}{MS_{error}}$$

$$F(df_{conditions}, df_{error}) = \text{calculated value}$$

Finally, compare the calculated value with the critical value in the F distribution tables at the chosen level of significance. The calculated value of F is only significant if it is equal to or larger than the table value.

The ANOVA calculations provided by statistical software (Minitab 19.0) was shown in the following example.

General Linear Model: response versus Participants, Layouts

Analysis of Variance

| Source | DF | Adj SS | Adj MS | F-Value | P-Value |
|--------------|----|--------|--------|---------|---------|
| Participants | 21 | 492.6 | 23.46 | 1.80 | 0.039 |
| Layouts | 3 | 390.0 | 129.99 | 9.95 | 0.000 |
| Error | 63 | 823.1 | 13.06 | | |
| Total | 87 | 1705.7 | | | |

Comparisons for response

Fisher Pairwise Comparisons: Layouts

Grouping Information Using Fisher LSD Method and 95% Confidence

| Layouts | N | Mean | Grouping |
|---------|----|---------|----------|
| C-Div | 22 | 13.4137 | A |
| V-Div | 22 | 9.9433 | B |
| D-Div | 22 | 9.6027 | B C |
| H-Div | 22 | 7.5549 | C |

Means that do not share a letter are significantly different.

As the calculated value of F is greater than the table value, we can reject the null hypothesis and accept the alternative hypothesis (Not all means are equal) at $p = 0.05$. It can be concluded that there is a significant difference in the mean distance error between the alignments in the layouts.

The table shown critical values of the F distribution.

0.05 Level of significance

| df2 | df1 | | | | | | | | | | | | |
|----------|--------|--------|--------|--------|--------|--------|--------|--------|--------|--------|--------|----------|--|
| | 1 | 2 | 3 | 4 | 5 | 6 | 7 | 8 | 9 | 10 | 20 | ∞ | |
| 1 | 161.45 | 199.50 | 215.71 | 224.58 | 230.16 | 233.99 | 236.77 | 238.88 | 240.54 | 241.88 | 248.01 | 254.32 | |
| 2 | 18.51 | 19.00 | 19.16 | 19.25 | 19.30 | 19.33 | 19.35 | 19.37 | 19.38 | 19.40 | 19.45 | 19.50 | |
| 3 | 10.13 | 9.55 | 9.28 | 9.12 | 9.01 | 8.94 | 8.89 | 8.85 | 8.81 | 8.79 | 8.66 | 8.53 | |
| 4 | 7.71 | 6.94 | 6.59 | 6.39 | 6.26 | 6.16 | 6.09 | 6.04 | 6.00 | 5.96 | 5.80 | 5.63 | |
| 5 | 6.61 | 5.79 | 5.41 | 5.19 | 5.05 | 4.95 | 4.88 | 4.82 | 4.77 | 4.74 | 4.56 | 4.36 | |
| 6 | 5.99 | 5.14 | 4.76 | 4.53 | 4.39 | 4.28 | 4.21 | 4.15 | 4.10 | 4.06 | 3.87 | 3.67 | |
| 7 | 5.59 | 4.74 | 4.35 | 4.12 | 3.97 | 3.87 | 3.79 | 3.73 | 3.68 | 3.64 | 3.44 | 3.23 | |
| 8 | 5.32 | 4.46 | 4.07 | 3.84 | 3.69 | 3.58 | 3.50 | 3.44 | 3.39 | 3.35 | 3.15 | 2.93 | |
| 9 | 5.12 | 4.26 | 3.86 | 3.63 | 3.48 | 3.37 | 3.29 | 3.23 | 3.18 | 3.14 | 3.07 | 3.01 | |
| 10 | 4.96 | 4.10 | 3.71 | 3.48 | 3.33 | 3.22 | 3.14 | 3.07 | 3.02 | 2.98 | 2.77 | 2.54 | |
| 11 | 4.84 | 3.98 | 3.59 | 3.36 | 3.20 | 3.09 | 3.01 | 2.95 | 2.90 | 2.85 | 2.65 | 2.40 | |
| 12 | 4.75 | 3.89 | 3.49 | 3.26 | 3.11 | 3.00 | 2.91 | 2.85 | 2.80 | 2.75 | 2.54 | 2.30 | |
| 13 | 4.67 | 3.81 | 3.41 | 3.18 | 3.03 | 2.92 | 2.83 | 2.77 | 2.71 | 2.67 | 2.46 | 2.21 | |
| 14 | 4.60 | 3.74 | 3.34 | 3.11 | 2.96 | 2.85 | 2.76 | 2.70 | 2.65 | 2.60 | 2.39 | 2.13 | |
| 15 | 4.54 | 3.68 | 3.29 | 3.06 | 2.90 | 2.79 | 2.71 | 2.64 | 2.59 | 2.54 | 2.33 | 2.07 | |
| 16 | 4.49 | 3.63 | 3.24 | 3.01 | 2.85 | 2.74 | 2.66 | 2.59 | 2.54 | 2.49 | 2.28 | 2.01 | |
| 17 | 4.45 | 3.59 | 3.20 | 2.96 | 2.81 | 2.70 | 2.61 | 2.55 | 2.49 | 2.45 | 2.23 | 1.96 | |
| 18 | 4.41 | 3.55 | 3.16 | 2.93 | 2.77 | 2.66 | 2.58 | 2.51 | 2.46 | 2.41 | 2.19 | 1.92 | |
| 19 | 4.38 | 3.52 | 3.13 | 2.90 | 2.74 | 2.63 | 2.54 | 2.48 | 2.42 | 2.38 | 2.16 | 1.88 | |
| 20 | 4.35 | 3.49 | 3.10 | 2.87 | 2.71 | 2.60 | 2.51 | 2.45 | 2.39 | 2.35 | 2.12 | 1.84 | |
| 21 | 4.32 | 3.47 | 3.07 | 2.84 | 2.68 | 2.57 | 2.49 | 2.42 | 2.37 | 2.32 | 2.10 | 1.81 | |
| 22 | 4.30 | 3.44 | 3.05 | 2.82 | 2.66 | 2.55 | 2.46 | 2.40 | 2.34 | 2.30 | 2.07 | 1.78 | |
| 23 | 4.28 | 3.42 | 3.03 | 2.80 | 2.64 | 2.53 | 2.44 | 2.37 | 2.32 | 2.27 | 2.05 | 1.76 | |
| 24 | 4.26 | 3.40 | 3.01 | 2.78 | 2.62 | 2.51 | 2.42 | 2.36 | 2.30 | 2.25 | 2.03 | 1.73 | |
| 25 | 4.24 | 3.39 | 2.99 | 2.76 | 2.60 | 2.49 | 2.40 | 2.34 | 2.28 | 2.24 | 2.01 | 1.71 | |
| 26 | 4.23 | 3.37 | 2.98 | 2.74 | 2.59 | 2.47 | 2.39 | 2.32 | 2.27 | 2.22 | 1.99 | 1.69 | |
| 27 | 4.21 | 3.35 | 2.96 | 2.73 | 2.57 | 2.46 | 2.37 | 2.31 | 2.25 | 2.20 | 1.97 | 1.67 | |
| 28 | 4.20 | 3.34 | 2.95 | 2.71 | 2.56 | 2.45 | 2.36 | 2.29 | 2.24 | 2.19 | 1.96 | 1.65 | |
| 29 | 4.18 | 3.33 | 2.93 | 2.70 | 2.55 | 2.43 | 2.35 | 2.28 | 2.22 | 2.18 | 1.94 | 1.64 | |
| 30 | 4.17 | 3.32 | 2.92 | 2.69 | 2.53 | 2.42 | 2.33 | 2.27 | 2.21 | 2.16 | 1.93 | 1.62 | |
| 40 | 4.08 | 3.23 | 2.84 | 2.61 | 2.45 | 2.34 | 2.25 | 2.18 | 2.12 | 2.08 | 1.84 | 1.51 | |
| 60 | 4.00 | 3.15 | 2.76 | 2.53 | 2.37 | 2.25 | 2.17 | 2.10 | 2.04 | 1.99 | 1.75 | 1.39 | |
| 120 | 3.92 | 3.07 | 2.68 | 2.45 | 2.29 | 2.18 | 2.09 | 2.02 | 1.96 | 1.91 | 1.66 | 1.25 | |
| ∞ | 3.84 | 3.00 | 2.60 | 2.37 | 2.21 | 2.10 | 2.01 | 1.94 | 1.88 | 1.83 | 1.57 | 1.00 | |

Appendix 6 Data on the distance error from Experiment 1

Set 1 >> The Un-1 layout in serial presentation mode

| | 1 | 2 | 3 | 4 | 5 | 6 | 7 | 8 | 9 | 10 | 11 |
|------------|------|------|------|------|------|------|------|------|------|------|------|
| Position 1 | 12.5 | 14.7 | 32.9 | 58.9 | 12.9 | 9.9 | 42.7 | 10.9 | 9.7 | 41.8 | 3.0 |
| Position 1 | 11.6 | 19.2 | 41.5 | 56.7 | 3.8 | 5.0 | 48.8 | 16.3 | 7.5 | 35.1 | 11.1 |
| Position 1 | 12.7 | 22.7 | 45.0 | 66.8 | 5.5 | 8.5 | 41.2 | 15.1 | 14.2 | 65.3 | 12.2 |
| Position 2 | 11.5 | 6.8 | 21.1 | 35.1 | 14.4 | 18.6 | 23.6 | 15.6 | 28.4 | 24.4 | 8.5 |
| Position 2 | 6.3 | 6.1 | 28.4 | 38.9 | 14.5 | 24.5 | 14.1 | 18.8 | 24.1 | 28.9 | 7.9 |
| Position 2 | 8.1 | 8.1 | 26.6 | 30.2 | 1.2 | 26.6 | 6.8 | 23.0 | 15.6 | 21.0 | 6.6 |
| Position 3 | 17.4 | 7.0 | 15.1 | 8.6 | 4.4 | 21.4 | 4.5 | 19.5 | 14.1 | 20.7 | 3.4 |
| Position 3 | 18.5 | 8.3 | 14.0 | 71.5 | 9.4 | 19.9 | 7.4 | 12.5 | 13.1 | 15.0 | 5.7 |
| Position 3 | 13.8 | 11.3 | 29.8 | 72.6 | 7.2 | 22.8 | 7.9 | 16.4 | 13.5 | 18.7 | 5.4 |
| Position 4 | 13.0 | 13.3 | 21.2 | 16.5 | 2.6 | 11.8 | 21.0 | 8.6 | 6.1 | 18.2 | 3.3 |
| Position 4 | 10.2 | 5.7 | 21.5 | 20.2 | 0.9 | 10.3 | 19.7 | 6.2 | 5.8 | 20.9 | 10.2 |
| Position 4 | 7.1 | 4.3 | 24.3 | 15.0 | 5.4 | 14.8 | 22.8 | 4.8 | 11.9 | 22.3 | 6.3 |

Set 1 >> The Un-1 layout in serial presentation mode (continued)

| | 12 | 13 | 14 | 15 | 16 | 17 | 18 | 19 | 20 | 21 | 22 |
|------------|------|------|------|------|------|------|------|------|------|------|------|
| Position 1 | 70.3 | 2.9 | 43.8 | 14.5 | 3.4 | 8.5 | 17.0 | 18.1 | 18.7 | 22.9 | 13.8 |
| Position 1 | 77.2 | 6.1 | 46.2 | 17.4 | 8.6 | 16.8 | 16.4 | 20.7 | 19.0 | 8.5 | 25.8 |
| Position 1 | 42.8 | 1.1 | 47.3 | 21.8 | 4.3 | 12.7 | 15.6 | 22.3 | 17.3 | 22.7 | 20.8 |
| Position 2 | 9.4 | 22.1 | 16.9 | 3.8 | 18.1 | 6.0 | 15.8 | 45.3 | 5.7 | 5.0 | 16.8 |
| Position 2 | 6.6 | 19.4 | 16.8 | 13.2 | 21.2 | 9.1 | 24.6 | 44.9 | 6.1 | 9.2 | 18.3 |
| Position 2 | 16.4 | 16.8 | 7.7 | 8.1 | 13.9 | 3.4 | 18.6 | 40.7 | 9.6 | 6.5 | 19.3 |
| Position 3 | 29.5 | 8.7 | 13.4 | 10.6 | 9.6 | 19.7 | 9.2 | 12.7 | 15.9 | 9.7 | 16.6 |
| Position 3 | 7.4 | 3.9 | 16.3 | 17.9 | 3.9 | 10.2 | 18.5 | 20.4 | 16.7 | 13.4 | 20.1 |
| Position 3 | 5.5 | 13.3 | 14.9 | 8.9 | 8.3 | 8.1 | 14.6 | 15.5 | 9.2 | 3.7 | 11.7 |
| Position 4 | 17.5 | 1.6 | 19.1 | 27.9 | 8.2 | 3.1 | 8.1 | 11.7 | 10.1 | 11.0 | 13.6 |
| Position 4 | 13.3 | 12.3 | 18.5 | 15.9 | 5.2 | 8.9 | 9.9 | 11.9 | 5.1 | 17.9 | 3.2 |
| Position 4 | 24.1 | 5.4 | 8.6 | 15.0 | 16.1 | 10.0 | 8.9 | 6.4 | 4.6 | 12.1 | 4.3 |

Set 1 >> The Un-2 layout in serial presentation mode

| | 1 | 2 | 3 | 4 | 5 | 6 | 7 | 8 | 9 | 10 | 11 |
|------------|------|------|------|------|------|------|------|------|------|------|------|
| Position 1 | 25.8 | 9.6 | 24.7 | 34.5 | 8.2 | 21.3 | 23.4 | 7.6 | 18.4 | 4.5 | 18.4 |
| Position 1 | 20.9 | 13.0 | 12.2 | 36.1 | 7.3 | 15.1 | 16.1 | 8.8 | 18.4 | 5.3 | 5.6 |
| Position 1 | 21.2 | 14.8 | 19.3 | 41.9 | 7.6 | 22.5 | 17.8 | 13.8 | 19.2 | 6.9 | 12.6 |
| Position 2 | 22.1 | 12.7 | 32.9 | 40.0 | 16.6 | 13.6 | 13.4 | 8.6 | 12.2 | 5.9 | 3.2 |
| Position 2 | 16.3 | 12.2 | 24.6 | 21.2 | 9.6 | 14.5 | 5.4 | 7.8 | 6.7 | 10.0 | 4.5 |
| Position 2 | 16.8 | 7.7 | 41.4 | 18.8 | 16.4 | 8.9 | 10.5 | 12.3 | 7.9 | 16.3 | 13.2 |
| Position 3 | 9.9 | 27.5 | 30.3 | 54.8 | 9.8 | 38.1 | 29.4 | 16.8 | 2.2 | 27.1 | 16.7 |
| Position 3 | 9.8 | 16.7 | 40.3 | 53.3 | 12.4 | 37.0 | 14.5 | 15.7 | 13.5 | 27.1 | 13.8 |
| Position 3 | 11.0 | 10.8 | 25.0 | 52.0 | 7.8 | 26.5 | 16.0 | 16.3 | 58.9 | 26.3 | 10.8 |
| Position 4 | 15.5 | 23.0 | 26.5 | 20.0 | 16.7 | 11.8 | 20.0 | 22.5 | 35.0 | 18.3 | 14.1 |
| Position 4 | 15.3 | 26.1 | 30.1 | 19.3 | 17.2 | 8.8 | 17.6 | 32.2 | 19.3 | 25.4 | 19.3 |
| Position 4 | 14.0 | 22.8 | 28.4 | 21.9 | 7.4 | 9.2 | 12.3 | 19.9 | 36.8 | 11.4 | 22.4 |

Set 1 >> The Un-2 layout in serial presentation mode (continued)

| | 12 | 13 | 14 | 15 | 16 | 17 | 18 | 19 | 20 | 21 | 22 |
|------------|------|------|------|------|------|------|------|------|------|------|------|
| Position 1 | 6.0 | 17.6 | 12.7 | 17.7 | 32.6 | 26.4 | 12.5 | 24.6 | 3.3 | 6.3 | 14.2 |
| Position 1 | 9.3 | 23.3 | 11.5 | 5.6 | 30.2 | 24.0 | 19.3 | 21.4 | 8.7 | 8.7 | 38.2 |
| Position 1 | 24.0 | 21.1 | 4.7 | 8.6 | 22.0 | 15.1 | 19.0 | 66.8 | 5.1 | 11.5 | 12.8 |
| Position 2 | 32.0 | 11.0 | 10.3 | 1.4 | 14.8 | 14.4 | 13.1 | 7.0 | 20.9 | 15.8 | 26.6 |
| Position 2 | 29.1 | 8.0 | 5.4 | 42.1 | 22.7 | 10.0 | 10.5 | 7.1 | 18.8 | 8.8 | 28.5 |
| Position 2 | 26.7 | 13.3 | 6.9 | 16.2 | 17.2 | 12.1 | 10.9 | 44.5 | 27.1 | 13.4 | 28.3 |
| Position 3 | 43.3 | 5.0 | 5.7 | 35.3 | 21.0 | 9.1 | 25.7 | 18.4 | 12.9 | 11.1 | 5.6 |
| Position 3 | 58.0 | 7.0 | 18.7 | 18.8 | 17.9 | 15.1 | 18.7 | 25.6 | 18.8 | 12.2 | 9.4 |
| Position 3 | 44.7 | 5.8 | 27.3 | 30.7 | 16.7 | 8.6 | 23.4 | 23.8 | 13.7 | 4.2 | 11.4 |
| Position 4 | 17.1 | 4.7 | 15.9 | 34.0 | 29.4 | 14.9 | 6.7 | 10.9 | 25.4 | 26.7 | 24.0 |
| Position 4 | 15.4 | 4.8 | 8.8 | 20.8 | 23.0 | 7.4 | 7.6 | 10.0 | 24.9 | 28.6 | 20.5 |
| Position 4 | 10.5 | 3.1 | 9.8 | 20.4 | 25.2 | 1.4 | 10.1 | 50.6 | 24.9 | 25.0 | 20.4 |

Set 1 >> The Un-1M layout in serial presentation mode

| | 1 | 2 | 3 | 4 | 5 | 6 | 7 | 8 | 9 | 10 | 11 |
|------------|------|------|------|------|------|------|------|------|------|------|------|
| Position 1 | 3.8 | 10.7 | 35.8 | 69.2 | 14.0 | 13.7 | 23.2 | 11.7 | 65.2 | 23.2 | 7.3 |
| Position 1 | 3.4 | 21.1 | 38.0 | 63.4 | 20.9 | 3.7 | 18.8 | 18.0 | 66.4 | 28.1 | 9.7 |
| Position 1 | 7.3 | 23.6 | 43.5 | 65.3 | 15.0 | 9.3 | 21.6 | 12.7 | 70.1 | 34.6 | 7.7 |
| Position 2 | 4.8 | 13.6 | 16.3 | 14.8 | 4.6 | 17.9 | 11.8 | 26.9 | 15.3 | 7.8 | 10.2 |
| Position 2 | 5.1 | 12.5 | 12.3 | 51.4 | 4.9 | 18.8 | 2.3 | 19.2 | 21.9 | 4.1 | 5.3 |
| Position 2 | 11.3 | 17.9 | 21.8 | 17.9 | 1.7 | 11.9 | 4.0 | 18.3 | 19.3 | 8.5 | 11.5 |
| Position 3 | 22.7 | 10.7 | 29.3 | 52.5 | 9.7 | 21.8 | 5.5 | 15.8 | 45.6 | 6.5 | 7.8 |
| Position 3 | 5.5 | 15.9 | 24.7 | 53.2 | 4.9 | 17.5 | 14.1 | 22.1 | 56.2 | 14.9 | 13.8 |
| Position 3 | 20.9 | 11.9 | 19.0 | 56.9 | 8.3 | 18.8 | 24.4 | 20.3 | 46.4 | 6.4 | 11.7 |
| Position 4 | 27.1 | 37.8 | 27.0 | 53.3 | 6.8 | 15.1 | 17.0 | 7.2 | 45.6 | 18.3 | 9.0 |
| Position 4 | 35.6 | 40.7 | 25.0 | 47.6 | 17.1 | 15.1 | 20.2 | 10.8 | 44.8 | 19.0 | 12.3 |
| Position 4 | 26.5 | 38.6 | 35.7 | 48.8 | 10.9 | 17.3 | 21.6 | 10.4 | 50.4 | 14.2 | 11.3 |

Set 1 >> The Un-1M layout in serial presentation mode (continued)

| | 12 | 13 | 14 | 15 | 16 | 17 | 18 | 19 | 20 | 21 | 22 |
|------------|------|------|------|------|------|------|------|------|------|------|------|
| Position 1 | 6.0 | 11.1 | 6.0 | 58.5 | 4.7 | 14.5 | 9.7 | 17.6 | 8.0 | 4.7 | 13.6 |
| Position 1 | 10.9 | 4.8 | 3.1 | 50.2 | 4.7 | 14.1 | 9.8 | 26.7 | 8.8 | 4.2 | 16.1 |
| Position 1 | 12.3 | 6.5 | 3.8 | 52.5 | 2.9 | 22.3 | 15.2 | 31.6 | 3.8 | 2.9 | 9.3 |
| Position 2 | 15.6 | 12.0 | 16.8 | 11.6 | 15.3 | 22.4 | 15.9 | 31.5 | 27.4 | 17.9 | 16.0 |
| Position 2 | 2.0 | 18.2 | 9.4 | 11.1 | 13.4 | 40.4 | 20.5 | 42.4 | 16.8 | 12.7 | 10.5 |
| Position 2 | 20.4 | 25.1 | 15.9 | 9.3 | 14.8 | 39.1 | 17.6 | 41.7 | 21.8 | 18.0 | 15.0 |
| Position 3 | 8.1 | 7.9 | 10.6 | 37.0 | 3.3 | 34.8 | 11.7 | 33.4 | 20.8 | 9.7 | 30.5 |
| Position 3 | 11.2 | 3.3 | 32.7 | 53.6 | 2.2 | 42.5 | 11.3 | 36.3 | 21.3 | 12.5 | 10.0 |
| Position 3 | 17.7 | 11.0 | 17.4 | 46.8 | 6.4 | 37.8 | 14.1 | 37.6 | 14.9 | 16.1 | 9.4 |
| Position 4 | 9.7 | 5.5 | 21.7 | 34.5 | 15.1 | 29.8 | 14.4 | 20.5 | 18.0 | 16.0 | 4.6 |
| Position 4 | 12.2 | 20.1 | 57.0 | 42.3 | 11.1 | 26.3 | 17.0 | 25.0 | 23.3 | 21.1 | 4.8 |
| Position 4 | 18.7 | 18.0 | 35.2 | 45.3 | 8.7 | 22.9 | 14.0 | 34.6 | 12.6 | 24.0 | 9.0 |

Set 1 >> The Un-2M layout in serial presentation mode

| | 1 | 2 | 3 | 4 | 5 | 6 | 7 | 8 | 9 | 10 | 11 |
|------------|------|------|------|------|------|------|------|------|------|------|------|
| Position 1 | 38.8 | 29.4 | 37.8 | 14.7 | 16.7 | 15.7 | 1.4 | 11.0 | 36.9 | 10.1 | 17.8 |
| Position 1 | 40.2 | 26.1 | 31.0 | 24.2 | 22.3 | 13.7 | 4.9 | 15.8 | 41.0 | 13.5 | 16.3 |
| Position 1 | 40.9 | 18.5 | 27.2 | 17.4 | 14.5 | 9.7 | 30.7 | 20.9 | 37.3 | 9.9 | 19.3 |
| Position 2 | 28.3 | 17.7 | 20.5 | 22.8 | 18.5 | 16.4 | 21.8 | 17.1 | 48.0 | 17.2 | 13.2 |
| Position 2 | 25.9 | 9.8 | 28.9 | 30.9 | 15.3 | 2.8 | 24.9 | 17.7 | 45.2 | 6.2 | 7.1 |
| Position 2 | 35.5 | 4.7 | 14.5 | 24.5 | 9.1 | 8.8 | 15.2 | 21.8 | 42.0 | 16.1 | 13.7 |
| Position 3 | 10.1 | 35.6 | 49.7 | 17.4 | 4.5 | 28.9 | 10.1 | 8.9 | 57.6 | 16.2 | 17.3 |
| Position 3 | 8.4 | 34.7 | 49.5 | 21.9 | 8.0 | 40.5 | 6.2 | 15.4 | 59.5 | 20.3 | 16.9 |
| Position 3 | 9.4 | 28.4 | 47.4 | 20.7 | 9.7 | 29.5 | 3.9 | 15.1 | 64.1 | 27.0 | 22.4 |
| Position 4 | 13.2 | 24.4 | 32.0 | 39.8 | 6.2 | 29.1 | 11.2 | 3.5 | 33.4 | 22.1 | 13.3 |
| Position 4 | 13.1 | 25.5 | 33.3 | 39.6 | 3.9 | 30.4 | 16.4 | 31.0 | 39.6 | 21.0 | 14.9 |
| Position 4 | 11.4 | 25.4 | 21.2 | 43.1 | 8.6 | 39.6 | 15.5 | 3.5 | 40.7 | 30.4 | 4.5 |

Set 1 >> The Un-2M layout in serial presentation mode (continued)

| | 12 | 13 | 14 | 15 | 16 | 17 | 18 | 19 | 20 | 21 | 22 |
|------------|------|------|------|------|------|------|------|------|------|------|------|
| Position 1 | 35.4 | 17.3 | 36.2 | 31.0 | 21.0 | 34.5 | 2.8 | 42.0 | 21.9 | 12.8 | 23.2 |
| Position 1 | 38.4 | 20.4 | 21.4 | 23.2 | 26.2 | 38.1 | 14.5 | 44.7 | 24.2 | 20.7 | 30.7 |
| Position 1 | 40.1 | 19.5 | 29.2 | 2.0 | 14.1 | 38.2 | 12.8 | 59.0 | 19.2 | 20.8 | 16.0 |
| Position 2 | 41.3 | 2.6 | 5.5 | 38.0 | 24.7 | 24.1 | 6.0 | 45.7 | 10.4 | 5.4 | 4.4 |
| Position 2 | 60.7 | 23.0 | 8.3 | 14.3 | 30.2 | 22.1 | 13.9 | 43.6 | 11.1 | 10.0 | 13.0 |
| Position 2 | 31.4 | 3.0 | 11.9 | 30.6 | 19.5 | 24.3 | 12.2 | 47.0 | 24.0 | 15.4 | 15.4 |
| Position 3 | 33.2 | 13.6 | 31.6 | 8.2 | 14.2 | 58.1 | 31.7 | 40.3 | 25.1 | 22.6 | 27.5 |
| Position 3 | 42.5 | 2.5 | 18.1 | 16.1 | 6.4 | 38.8 | 14.0 | 29.5 | 14.7 | 15.3 | 17.9 |
| Position 3 | 21.5 | 8.7 | 3.8 | 21.7 | 7.2 | 54.4 | 16.2 | 31.5 | 22.7 | 11.7 | 21.1 |
| Position 4 | 34.3 | 3.5 | 34.3 | 9.0 | 17.2 | 35.6 | 6.7 | 23.1 | 30.8 | 12.8 | 16.0 |
| Position 4 | 46.3 | 3.6 | 41.2 | 8.1 | 17.5 | 29.4 | 7.7 | 29.8 | 38.6 | 16.4 | 18.4 |
| Position 4 | 44.8 | 5.2 | 26.8 | 16.0 | 16.7 | 28.3 | 4.8 | 31.6 | 22.6 | 10.6 | 16.8 |

Set 2 >> Position 1

| | 1 | 2 | 3 | 4 | 5 | 6 | 7 | 8 | 9 | 10 | 11 |
|----------|------|------|------|------|------|------|------|------|------|------|------|
| Layout H | 2.2 | 11.5 | 42.8 | 3.8 | 5.4 | 11.0 | 3.0 | 12.5 | 7.3 | 18.6 | 9.9 |
| Layout H | 4.1 | 4.7 | 47.4 | 2.8 | 4.3 | 10.9 | 1.3 | 13.7 | 7.2 | 16.5 | 8.6 |
| Layout H | 4.4 | 4.1 | 58.7 | 5.2 | 7.2 | 9.1 | 2.7 | 15.0 | 1.4 | 43.8 | 6.5 |
| Layout V | 37.4 | 22.8 | 39.4 | 42.8 | 23.9 | 10.5 | 2.5 | 8.9 | 16.7 | 15.9 | 3.1 |
| Layout V | 39.3 | 32.0 | 44.2 | 44.1 | 21.9 | 10.0 | 9.9 | 8.7 | 17.4 | 21.2 | 2.5 |
| Layout V | 42.5 | 23.9 | 43.1 | 34.1 | 15.8 | 17.9 | 9.0 | 9.7 | 23.9 | 5.8 | 9.1 |
| Layout D | 37.9 | 18.9 | 23.6 | 42.3 | 11.0 | 19.3 | 19.3 | 13.1 | 5.6 | 24.5 | 8.2 |
| Layout D | 45.9 | 24.0 | 32.5 | 36.3 | 8.3 | 20.0 | 24.8 | 12.2 | 3.4 | 21.6 | 6.7 |
| Layout D | 39.8 | 20.8 | 37.1 | 46.1 | 11.5 | 6.2 | 17.0 | 3.4 | 6.4 | 13.2 | 3.9 |
| Layout C | 33.2 | 20.6 | 74.2 | 78.1 | 15.2 | 28.1 | 15.6 | 14.1 | 16.4 | 27.8 | 24.5 |
| Layout C | 40.4 | 23.4 | 66.6 | 80.2 | 11.9 | 25.9 | 14.9 | 22.4 | 11.0 | 11.5 | 19.2 |
| Layout C | 42.0 | 11.5 | 82.9 | 74.1 | 17.3 | 47.5 | 14.0 | 43.4 | 11.5 | 19.6 | 21.2 |

Set 2 >> Position 1 (Continued)

| | 12 | 13 | 14 | 15 | 16 | 17 | 18 | 19 | 20 | 21 | 22 |
|----------|------|------|------|------|------|------|------|------|------|------|------|
| Layout H | 15.7 | 7.7 | 18.4 | 5.7 | 8.9 | 4.5 | 13.6 | 24.2 | 12.8 | 14.6 | 11.4 |
| Layout H | 19.0 | 8.0 | 26.9 | 7.2 | 5.4 | 12.3 | 9.7 | 13.1 | 11.5 | 12.3 | 8.2 |
| Layout H | 21.3 | 8.5 | 24.6 | 10.4 | 14.5 | 9.7 | 11.9 | 21.5 | 12.1 | 23.2 | 11.7 |
| Layout V | 4.4 | 14.9 | 11.6 | 11.1 | 11.8 | 23.3 | 9.6 | 23.6 | 27.0 | 6.0 | 14.3 |
| Layout V | 3.8 | 16.2 | 16.4 | 13.5 | 18.9 | 24.2 | 4.8 | 6.6 | 19.5 | 8.5 | 20.6 |
| Layout V | 12.9 | 23.6 | 12.4 | 14.4 | 17.7 | 30.9 | 6.3 | 15.2 | 30.4 | 12.3 | 20.2 |
| Layout D | 21.8 | 24.6 | 20.9 | 16.5 | 5.8 | 18.0 | 13.4 | 28.8 | 24.4 | 8.6 | 15.8 |
| Layout D | 16.6 | 14.4 | 31.6 | 12.1 | 7.5 | 13.5 | 10.4 | 22.2 | 22.2 | 12.6 | 20.2 |
| Layout D | 15.6 | 7.8 | 14.6 | 6.8 | 12.2 | 11.8 | 11.0 | 26.8 | 12.5 | 9.0 | 17.5 |
| Layout C | 2.7 | 14.7 | 44.7 | 9.5 | 11.7 | 23.6 | 20.0 | 30.3 | 19.6 | 7.5 | 17.2 |
| Layout C | 9.7 | 15.6 | 44.5 | 13.9 | 10.8 | 24.9 | 21.9 | 29.4 | 23.1 | 16.3 | 17.0 |
| Layout C | 24.5 | 19.6 | 71.9 | 9.6 | 16.8 | 20.9 | 19.4 | 28.6 | 15.7 | 35.5 | 11.7 |

Set 2 >> Position 2

| | 1 | 2 | 3 | 4 | 5 | 6 | 7 | 8 | 9 | 10 | 11 |
|----------|------|------|------|------|------|------|------|------|------|------|------|
| Layout H | 9.2 | 3.8 | 38.2 | 12.6 | 14.9 | 13.5 | 6.6 | 6.1 | 13.3 | 8.5 | 11.2 |
| Layout H | 7.3 | 15.0 | 33.5 | 10.6 | 13.6 | 20.2 | 12.2 | 4.5 | 10.3 | 22.9 | 9.5 |
| Layout H | 7.0 | 14.9 | 35.2 | 9.8 | 10.9 | 16.7 | 9.1 | 4.2 | 6.5 | 20.5 | 5.5 |
| Layout V | 39.5 | 6.9 | 45.1 | 23.0 | 21.3 | 14.3 | 50.1 | 16.1 | 52.5 | 10.4 | 6.5 |
| Layout V | 38.9 | 2.3 | 43.9 | 29.6 | 22.3 | 14.0 | 54.5 | 42.6 | 1.3 | 36.1 | 8.2 |
| Layout V | 39.4 | 5.2 | 32.9 | 20.4 | 13.5 | 10.0 | 53.9 | 44.5 | 7.2 | 12.7 | 4.0 |
| Layout D | 35.3 | 8.3 | 40.3 | 47.5 | 10.5 | 13.1 | 9.8 | 12.4 | 7.3 | 19.1 | 8.4 |
| Layout D | 41.2 | 12.1 | 34.6 | 26.4 | 6.6 | 9.7 | 8.0 | 8.5 | 8.6 | 21.9 | 5.6 |
| Layout D | 44.2 | 15.8 | 29.3 | 42.2 | 5.1 | 1.2 | 5.0 | 3.7 | 12.5 | 37.2 | 7.4 |
| Layout C | 31.4 | 10.4 | 38.7 | 23.1 | 11.2 | 12.3 | 26.9 | 8.0 | 5.1 | 22.4 | 12.1 |
| Layout C | 34.1 | 15.9 | 43.2 | 23.1 | 16.6 | 3.5 | 37.2 | 11.0 | 6.0 | 28.4 | 14.8 |
| Layout C | 49.6 | 21.0 | 40.2 | 52.8 | 20.5 | 4.5 | 29.7 | 14.1 | 20.3 | 28.0 | 6.0 |

Set 2 >> Position 2 (Continued)

| | 12 | 13 | 14 | 15 | 16 | 17 | 18 | 19 | 20 | 21 | 22 |
|----------|------|------|------|------|------|------|------|------|------|------|------|
| Layout H | 6.5 | 4.1 | 3.2 | 9.4 | 5.2 | 30.6 | 13.1 | 9.5 | 10.2 | 8.1 | 12.1 |
| Layout H | 19.0 | 12.3 | 11.3 | 6.1 | 9.8 | 27.6 | 2.6 | 15.1 | 8.1 | 12.3 | 8.0 |
| Layout H | 24.3 | 11.6 | 13.9 | 5.2 | 5.6 | 34.7 | 23.1 | 12.3 | 7.6 | 8.1 | 7.2 |
| Layout V | 2.4 | 21.3 | 12.0 | 9.9 | 10.7 | 33.4 | 5.3 | 3.2 | 26.4 | 4.2 | 21.8 |
| Layout V | 16.9 | 12.8 | 17.4 | 8.4 | 4.0 | 37.4 | 7.6 | 9.8 | 29.3 | 2.8 | 18.8 |
| Layout V | 14.2 | 10.0 | 16.9 | 4.6 | 10.7 | 30.1 | 5.3 | 4.3 | 28.6 | 5.1 | 18.9 |
| Layout D | 18.5 | 8.9 | 26.6 | 24.6 | 17.3 | 34.8 | 8.6 | 6.7 | 4.7 | 2.1 | 8.7 |
| Layout D | 18.8 | 16.6 | 31.0 | 11.9 | 15.4 | 43.7 | 16.5 | 8.6 | 32.9 | 11.2 | 29.7 |
| Layout D | 30.7 | 6.8 | 29.3 | 5.8 | 11.7 | 50.6 | 19.9 | 3.7 | 9.5 | 14.6 | 7.1 |
| Layout C | 11.6 | 5.7 | 28.5 | 23.9 | 17.3 | 21.9 | 6.6 | 24.0 | 13.0 | 19.4 | 14.7 |
| Layout C | 14.0 | 7.9 | 36.0 | 30.4 | 19.6 | 5.1 | 10.5 | 21.5 | 29.9 | 11.1 | 15.9 |
| Layout C | 19.9 | 13.4 | 30.5 | 22.3 | 25.0 | 31.7 | 13.7 | 21.3 | 29.9 | 17.9 | 22.4 |

Set 2 >> Position 3

| | 1 | 2 | 3 | 4 | 5 | 6 | 7 | 8 | 9 | 10 | 11 |
|----------|------|------|------|------|------|------|------|------|------|------|------|
| Layout H | 18.7 | 10.7 | 43.4 | 10.3 | 3.2 | 21.3 | 5.1 | 11.2 | 13.2 | 11.7 | 5.1 |
| Layout H | 15.0 | 7.9 | 43.8 | 3.2 | 7.1 | 10.0 | 4.6 | 19.0 | 4.6 | 21.1 | 13.8 |
| Layout H | 15.0 | 6.9 | 49.3 | 4.4 | 6.0 | 19.9 | 8.4 | 10.8 | 11.3 | 15.4 | 7.9 |
| Layout V | 35.2 | 11.0 | 45.8 | 26.3 | 17.4 | 11.1 | 11.2 | 8.9 | 1.4 | 20.9 | 13.7 |
| Layout V | 33.7 | 14.1 | 49.3 | 25.5 | 7.3 | 11.0 | 4.1 | 9.4 | 8.6 | 27.2 | 7.1 |
| Layout V | 41.1 | 1.6 | 49.8 | 25.9 | 2.5 | 14.8 | 4.8 | 7.6 | 9.5 | 17.2 | 5.0 |
| Layout D | 14.3 | 10.7 | 27.5 | 18.6 | 3.8 | 23.3 | 4.7 | 8.2 | 12.0 | 24.1 | 3.9 |
| Layout D | 26.4 | 14.7 | 26.3 | 32.8 | 13.7 | 15.3 | 3.8 | 12.6 | 11.5 | 38.7 | 3.4 |
| Layout D | 30.7 | 21.9 | 35.1 | 34.5 | 9.2 | 21.1 | 1.2 | 12.8 | 21.3 | 35.8 | 2.6 |
| Layout C | 10.0 | 13.3 | 31.7 | 43.0 | 8.0 | 21.2 | 6.5 | 19.5 | 23.7 | 31.7 | 12.4 |
| Layout C | 6.9 | 20.8 | 38.9 | 41.3 | 13.2 | 20.8 | 7.5 | 20.6 | 24.8 | 25.5 | 12.6 |
| Layout C | 16.2 | 21.7 | 37.4 | 37.5 | 19.1 | 9.2 | 9.0 | 21.5 | 17.2 | 22.0 | 14.0 |

Set 2 >> Position 3 (Continued)

| | 12 | 13 | 14 | 15 | 16 | 17 | 18 | 19 | 20 | 21 | 22 |
|----------|------|------|------|------|------|------|------|------|------|------|------|
| Layout H | 16.0 | 8.6 | 5.8 | 5.2 | 11.0 | 9.2 | 13.8 | 16.3 | 4.4 | 6.5 | 7.3 |
| Layout H | 28.0 | 12.6 | 8.8 | 8.1 | 14.5 | 15.6 | 20.1 | 5.1 | 1.4 | 12.1 | 9.4 |
| Layout H | 29.1 | 8.8 | 0.9 | 9.5 | 14.6 | 10.6 | 16.3 | 9.4 | 2.0 | 10.4 | 9.2 |
| Layout V | 22.2 | 15.9 | 12.0 | 6.8 | 20.0 | 39.2 | 13.1 | 5.8 | 13.6 | 10.0 | 9.2 |
| Layout V | 28.4 | 14.7 | 14.4 | 15.9 | 20.3 | 43.6 | 22.2 | 7.4 | 8.6 | 21.8 | 4.6 |
| Layout V | 29.1 | 17.8 | 6.3 | 4.4 | 7.6 | 21.1 | 5.5 | 9.4 | 5.2 | 12.1 | 18.0 |
| Layout D | 16.0 | 11.7 | 39.3 | 6.3 | 5.7 | 39.5 | 12.3 | 20.6 | 10.1 | 22.1 | 4.2 |
| Layout D | 27.1 | 11.5 | 28.5 | 10.9 | 9.9 | 28.6 | 24.8 | 4.8 | 17.1 | 33.9 | 22.1 |
| Layout D | 25.9 | 1.3 | 26.0 | 8.4 | 12.9 | 26.5 | 24.5 | 9.4 | 19.0 | 40.3 | 22.4 |
| Layout C | 18.1 | 13.0 | 37.3 | 19.9 | 32.9 | 26.0 | 10.4 | 39.9 | 10.4 | 3.4 | 4.7 |
| Layout C | 18.9 | 6.4 | 38.9 | 21.7 | 22.6 | 30.5 | 11.5 | 47.3 | 12.3 | 15.2 | 5.7 |
| Layout C | 19.4 | 9.6 | 15.7 | 8.7 | 21.8 | 25.9 | 15.1 | 36.2 | 6.0 | 11.9 | 7.9 |

Set 2 >> Position 4

| | 1 | 2 | 3 | 4 | 5 | 6 | 7 | 8 | 9 | 10 | 11 |
|----------|------|------|------|------|------|------|------|------|------|------|------|
| Layout H | 5.6 | 4.7 | 49.0 | 2.8 | 7.0 | 6.5 | 6.6 | 8.8 | 3.7 | 11.2 | 11.5 |
| Layout H | 5.6 | 10.2 | 53.4 | 13.4 | 14.0 | 5.5 | 2.4 | 10.0 | 12.2 | 75.2 | 14.4 |
| Layout H | 6.9 | 6.1 | 52.9 | 12.9 | 5.4 | 7.0 | 2.9 | 4.9 | 26.6 | 57.9 | 16.4 |
| Layout V | 5.5 | 3.5 | 56.4 | 6.6 | 11.9 | 6.2 | 3.9 | 15.7 | 14.6 | 15.8 | 9.3 |
| Layout V | 6.1 | 11.7 | 58.6 | 13.2 | 10.0 | 9.6 | 5.9 | 28.7 | 38.8 | 68.4 | 15.1 |
| Layout V | 4.0 | 8.0 | 54.2 | 5.9 | 9.9 | 6.3 | 12.1 | 8.2 | 1.8 | 22.7 | 9.9 |
| Layout D | 42.9 | 12.2 | 28.9 | 29.9 | 4.4 | 29.4 | 10.7 | 2.5 | 6.0 | 6.8 | 8.9 |
| Layout D | 41.3 | 11.6 | 41.0 | 20.2 | 2.9 | 35.6 | 16.3 | 4.0 | 19.9 | 6.2 | 11.6 |
| Layout D | 51.5 | 13.8 | 42.3 | 19.5 | 5.6 | 43.6 | 12.1 | 11.7 | 11.2 | 41.4 | 17.7 |
| Layout C | 14.7 | 8.8 | 30.4 | 14.8 | 9.7 | 13.3 | 22.6 | 17.3 | 12.6 | 62.6 | 11.3 |
| Layout C | 19.3 | 19.0 | 32.1 | 25.3 | 1.9 | 21.8 | 20.3 | 19.1 | 13.0 | 9.6 | 11.7 |
| Layout C | 16.8 | 23.8 | 31.1 | 30.0 | 3.7 | 12.6 | 29.5 | 9.5 | 60.9 | 70.7 | 18.1 |

Set 2 >> Position 4 (Continued)

| | 12 | 13 | 14 | 15 | 16 | 17 | 18 | 19 | 20 | 21 | 22 |
|----------|------|------|------|------|------|------|------|------|------|------|------|
| Layout H | 54.8 | 6.8 | 12.6 | 7.0 | 8.3 | 19.4 | 10.7 | 2.7 | 1.6 | 4.4 | 6.8 |
| Layout H | 29.9 | 7.6 | 15.9 | 9.4 | 12.9 | 12.9 | 4.0 | 11.3 | 1.4 | 3.8 | 11.5 |
| Layout H | 23.4 | 9.3 | 22.6 | 13.5 | 12.6 | 8.9 | 10.0 | 17.5 | 1.1 | 1.6 | 11.6 |
| Layout V | 27.5 | 19.5 | 9.5 | 7.5 | 10.6 | 26.2 | 1.9 | 10.0 | 0.8 | 4.1 | 10.0 |
| Layout V | 38.1 | 15.1 | 31.1 | 10.5 | 14.4 | 16.9 | 8.5 | 12.8 | 2.2 | 4.1 | 15.1 |
| Layout V | 29.6 | 11.6 | 28.1 | 9.0 | 15.4 | 15.3 | 6.2 | 10.8 | 3.5 | 3.2 | 10.0 |
| Layout D | 7.7 | 11.7 | 12.6 | 4.4 | 13.3 | 14.5 | 0.4 | 21.2 | 17.1 | 11.9 | 23.0 |
| Layout D | 16.8 | 10.4 | 20.6 | 15.8 | 10.1 | 20.9 | 11.3 | 15.3 | 58.6 | 12.0 | 14.2 |
| Layout D | 35.1 | 10.0 | 37.4 | 17.2 | 14.6 | 25.1 | 5.1 | 26.4 | 61.8 | 13.3 | 15.0 |
| Layout C | 11.5 | 14.1 | 6.3 | 15.7 | 25.6 | 9.4 | 15.4 | 21.7 | 47.1 | 25.2 | 8.3 |
| Layout C | 11.2 | 13.6 | 1.9 | 78.6 | 27.5 | 21.4 | 13.3 | 26.7 | 49.1 | 28.2 | 10.3 |
| Layout C | 6.7 | 17.6 | 7.9 | 12.3 | 26.3 | 10.9 | 35.7 | 16.5 | 8.8 | 35.9 | 5.4 |

Set 4 >> Position 1

| | 1 | 2 | 3 | 4 | 5 | 6 | 7 | 8 | 9 | 10 | 11 |
|--------------|------|------|------|------|------|------|------|------|------|------|------|
| Layout H-Div | 7.1 | 9.8 | 8.1 | 4.8 | 9.1 | 8.7 | 5.4 | 10.0 | 17.1 | 15.7 | 6.5 |
| Layout H-Div | 4.8 | 8.6 | 14.9 | 6.7 | 9.1 | 6.5 | 7.9 | 17.4 | 14.1 | 22.3 | 11.0 |
| Layout H-Div | 4.3 | 6.1 | 11.7 | 12.3 | 8.7 | 7.0 | 7.9 | 17.0 | 14.9 | 33.5 | 8.6 |
| Layout V-Div | 30.5 | 10.7 | 30.2 | 98.6 | 23.8 | 16.9 | 7.0 | 44.8 | 20.1 | 36.5 | 4.2 |
| Layout V-Div | 28.7 | 16.9 | 17.5 | 4.6 | 24.4 | 11.7 | 8.2 | 50.0 | 23.3 | 2.9 | 3.7 |
| Layout V-Div | 29.8 | 10.7 | 18.6 | 48.8 | 33.8 | 9.5 | 7.7 | 58.5 | 19.0 | 4.6 | 7.5 |
| Layout D-Div | 24.7 | 9.8 | 17.6 | 5.5 | 13.4 | 30.8 | 21.1 | 35.7 | 29.6 | 29.9 | 16.1 |
| Layout D-Div | 33.7 | 13.8 | 19.8 | 20.4 | 8.3 | 28.9 | 17.9 | 14.2 | 14.2 | 23.5 | 8.2 |
| Layout D-Div | 18.2 | 22.8 | 7.9 | 5.8 | 8.6 | 22.0 | 16.3 | 12.0 | 14.5 | 12.4 | 15.4 |
| Layout C-Div | 23.0 | 11.9 | 40.2 | 42.0 | 18.3 | 27.0 | 18.9 | 7.6 | 18.2 | 39.8 | 23.9 |
| Layout C-Div | 22.9 | 11.7 | 37.5 | 80.6 | 19.6 | 24.7 | 14.8 | 9.6 | 72.8 | 54.3 | 21.6 |
| Layout C-Div | 25.6 | 13.4 | 50.5 | 81.4 | 10.8 | 39.7 | 16.0 | 19.9 | 20.1 | 49.9 | 24.2 |

Set 4 >> Position 1 (Continued)

| | 12 | 13 | 14 | 15 | 16 | 17 | 18 | 19 | 20 | 21 | 22 |
|--------------|------|------|------|------|------|------|------|------|------|------|------|
| Layout H-Div | 14.1 | 5.8 | 27.4 | 16.5 | 4.0 | 3.3 | 14.3 | 14.8 | 16.0 | 7.6 | 4.3 |
| Layout H-Div | 26.9 | 5.7 | 28.8 | 9.4 | 2.1 | 9.0 | 15.0 | 13.0 | 9.3 | 4.4 | 5.4 |
| Layout H-Div | 9.5 | 8.2 | 30.0 | 13.7 | 9.5 | 3.0 | 16.0 | 15.4 | 16.0 | 5.1 | 5.8 |
| Layout V-Div | 15.5 | 10.7 | 27.7 | 23.7 | 10.2 | 24.3 | 2.9 | 10.6 | 25.1 | 7.1 | 36.5 |
| Layout V-Div | 10.3 | 9.3 | 32.0 | 27.3 | 20.0 | 26.5 | 6.3 | 12.8 | 36.3 | 15.5 | 21.6 |
| Layout V-Div | 11.6 | 9.4 | 11.3 | 25.9 | 13.8 | 33.7 | 6.1 | 13.2 | 22.0 | 10.5 | 28.9 |
| Layout D-Div | 20.4 | 17.7 | 24.7 | 6.2 | 7.3 | 23.4 | 14.0 | 18.0 | 31.2 | 22.9 | 19.7 |
| Layout D-Div | 20.4 | 19.2 | 32.9 | 22.7 | 14.4 | 21.1 | 24.0 | 12.2 | 15.2 | 47.2 | 16.5 |
| Layout D-Div | 14.9 | 8.9 | 19.5 | 16.0 | 2.4 | 15.5 | 24.1 | 12.5 | 5.7 | 1.5 | 32.2 |
| Layout C-Div | 13.2 | 14.0 | 29.3 | 19.4 | 6.0 | 2.9 | 10.3 | 11.8 | 11.5 | 26.8 | 15.6 |
| Layout C-Div | 29.6 | 16.7 | 25.2 | 21.4 | 2.3 | 6.3 | 15.7 | 14.6 | 30.4 | 39.2 | 13.3 |
| Layout C-Div | 23.1 | 19.9 | 30.8 | 22.2 | 10.8 | 20.8 | 18.1 | 18.8 | 12.0 | 37.3 | 99.4 |

Set 4 >> Position 2

| | 1 | 2 | 3 | 4 | 5 | 6 | 7 | 8 | 9 | 10 | 11 |
|--------------|------|------|------|------|------|------|------|------|------|------|------|
| Layout H-Div | 3.4 | 7.2 | 4.7 | 6.5 | 9.6 | 7.3 | 8.2 | 3.1 | 10.1 | 12.5 | 7.0 |
| Layout H-Div | 5.7 | 13.3 | 3.3 | 6.9 | 5.8 | 8.2 | 9.3 | 7.3 | 11.5 | 13.6 | 8.3 |
| Layout H-Div | 5.3 | 11.9 | 6.3 | 6.8 | 6.6 | 15.2 | 7.8 | 6.5 | 9.8 | 13.9 | 14.8 |
| Layout V-Div | 33.3 | 10.2 | 15.9 | 7.6 | 20.7 | 17.0 | 8.8 | 11.2 | 7.1 | 5.7 | 2.0 |
| Layout V-Div | 33.9 | 1.6 | 12.1 | 13.7 | 17.7 | 15.5 | 2.9 | 6.2 | 4.1 | 16.3 | 6.0 |
| Layout V-Div | 34.8 | 4.4 | 7.4 | 47.5 | 16.5 | 14.3 | 6.7 | 8.3 | 7.6 | 6.3 | 5.6 |
| Layout D-Div | 18.9 | 8.9 | 10.8 | 19.9 | 5.1 | 21.6 | 10.6 | 15.6 | 32.8 | 11.6 | 12.6 |
| Layout D-Div | 18.4 | 5.9 | 12.6 | 17.5 | 8.6 | 18.9 | 10.1 | 7.2 | 16.5 | 19.0 | 9.1 |
| Layout D-Div | 15.7 | 12.3 | 12.5 | 14.5 | 7.4 | 20.8 | 13.2 | 6.2 | 3.7 | 12.7 | 2.4 |
| Layout C-Div | 5.6 | 7.8 | 20.0 | 12.3 | 12.9 | 17.1 | 16.4 | 21.1 | 27.3 | 17.2 | 29.9 |
| Layout C-Div | 7.3 | 0.8 | 13.5 | 7.0 | 26.5 | 14.7 | 13.1 | 17.7 | 8.7 | 10.6 | 19.3 |
| Layout C-Div | 2.3 | 11.5 | 16.2 | 67.4 | 29.9 | 19.2 | 23.4 | 30.7 | 17.7 | 17.4 | 14.0 |

Set 4 >> Position 2 (Continued)

| | 12 | 13 | 14 | 15 | 16 | 17 | 18 | 19 | 20 | 21 | 22 |
|--------------|------|------|------|------|------|------|------|------|------|------|------|
| Layout H-Div | 22.5 | 5.9 | 14.8 | 10.6 | 10.3 | 20.7 | 16.6 | 9.1 | 13.7 | 7.2 | 10.9 |
| Layout H-Div | 34.6 | 11.3 | 11.4 | 6.7 | 11.0 | 17.5 | 7.6 | 15.8 | 4.9 | 9.6 | 7.3 |
| Layout H-Div | 31.1 | 5.3 | 14.1 | 5.5 | 8.9 | 26.1 | 11.4 | 14.2 | 11.2 | 1.0 | 7.1 |
| Layout V-Div | 16.2 | 9.5 | 9.1 | 14.4 | 16.2 | 67.4 | 5.8 | 17.5 | 25.0 | 9.6 | 15.1 |
| Layout V-Div | 48.2 | 7.8 | 16.2 | 20.5 | 16.4 | 32.6 | 3.8 | 14.9 | 27.5 | 21.2 | 19.3 |
| Layout V-Div | 23.1 | 8.6 | 3.3 | 23.5 | 16.2 | 48.6 | 5.3 | 26.8 | 35.0 | 12.8 | 16.3 |
| Layout D-Div | 16.3 | 12.7 | 13.7 | 12.8 | 20.0 | 7.1 | 8.5 | 9.6 | 25.8 | 20.1 | 8.7 |
| Layout D-Div | 34.0 | 16.4 | 35.5 | 11.6 | 8.0 | 33.3 | 8.8 | 11.7 | 28.3 | 28.0 | 14.0 |
| Layout D-Div | 26.8 | 12.7 | 19.6 | 9.5 | 19.8 | 29.2 | 4.0 | 12.7 | 26.2 | 27.9 | 3.2 |
| Layout C-Div | 9.9 | 8.5 | 12.4 | 14.8 | 12.8 | 7.5 | 5.2 | 26.3 | 12.7 | 13.4 | 4.8 |
| Layout C-Div | 48.4 | 3.4 | 22.5 | 16.1 | 17.6 | 11.5 | 5.3 | 31.2 | 27.9 | 12.0 | 15.3 |
| Layout C-Div | 41.5 | 21.1 | 29.5 | 20.5 | 12.3 | 15.9 | 2.4 | 25.7 | 12.4 | 12.0 | 4.3 |

Set 4 >> Position 3

| | 1 | 2 | 3 | 4 | 5 | 6 | 7 | 8 | 9 | 10 | 11 |
|--------------|------|------|------|------|------|------|------|------|------|------|------|
| Layout H-Div | 14.6 | 7.1 | 11.9 | 8.6 | 7.9 | 21.6 | 6.9 | 11.3 | 17.6 | 18.0 | 5.5 |
| Layout H-Div | 14.2 | 7.8 | 17.1 | 15.9 | 9.1 | 9.8 | 9.5 | 10.8 | 19.5 | 21.0 | 12.4 |
| Layout H-Div | 15.4 | 5.9 | 20.0 | 22.8 | 9.7 | 11.3 | 11.1 | 12.9 | 23.5 | 24.0 | 7.6 |
| Layout V-Div | 35.1 | 4.4 | 21.6 | 53.3 | 22.9 | 10.0 | 14.7 | 14.3 | 27.6 | 29.0 | 15.6 |
| Layout V-Div | 34.4 | 6.6 | 23.4 | 57.8 | 26.0 | 15.7 | 7.7 | 14.5 | 29.7 | 30.8 | 16.7 |
| Layout V-Div | 32.0 | 3.2 | 15.5 | 29.3 | 14.5 | 13.0 | 2.0 | 3.4 | 27.5 | 26.9 | 21.0 |
| Layout D-Div | 19.1 | 21.3 | 5.1 | 29.3 | 5.1 | 18.1 | 19.9 | 3.6 | 10.3 | 23.1 | 13.2 |
| Layout D-Div | 22.5 | 19.9 | 3.8 | 34.9 | 6.3 | 6.7 | 19.8 | 12.9 | 26.6 | 39.6 | 6.9 |
| Layout D-Div | 24.2 | 25.3 | 11.2 | 46.6 | 4.0 | 39.4 | 24.1 | 13.1 | 25.1 | 26.8 | 3.9 |
| Layout C-Div | 8.5 | 10.2 | 11.6 | 23.8 | 20.6 | 22.6 | 6.0 | 5.7 | 23.6 | 6.1 | 8.1 |
| Layout C-Div | 10.4 | 25.0 | 24.9 | 16.3 | 14.1 | 29.9 | 12.3 | 9.8 | 29.1 | 7.9 | 13.9 |
| Layout C-Div | 15.7 | 19.1 | 13.6 | 27.2 | 11.9 | 32.9 | 14.5 | 9.4 | 6.3 | 1.2 | 9.5 |

Set 4 >> Position 3 (Continued)

| | 12 | 13 | 14 | 15 | 16 | 17 | 18 | 19 | 20 | 21 | 22 |
|--------------|------|------|------|------|------|------|------|------|------|------|------|
| Layout H-Div | 24.4 | 11.0 | 16.6 | 13.3 | 4.8 | 15.6 | 1.9 | 8.2 | 3.3 | 8.4 | 4.2 |
| Layout H-Div | 50.8 | 16.5 | 9.9 | 13.9 | 5.1 | 9.8 | 9.8 | 18.1 | 4.6 | 3.4 | 11.6 |
| Layout H-Div | 17.0 | 9.4 | 11.9 | 10.3 | 7.1 | 14.9 | 7.1 | 19.6 | 5.3 | 1.9 | 12.7 |
| Layout V-Div | 69.9 | 29.3 | 7.8 | 7.9 | 25.7 | 45.8 | 10.5 | 26.1 | 19.5 | 9.4 | 2.7 |
| Layout V-Div | 56.4 | 17.7 | 22.7 | 25.7 | 22.8 | 40.3 | 8.1 | 26.3 | 24.4 | 17.4 | 0.8 |
| Layout V-Div | 30.2 | 15.5 | 19.7 | 8.0 | 9.6 | 36.8 | 6.4 | 29.2 | 18.1 | 12.5 | 6.5 |
| Layout D-Div | 38.3 | 8.1 | 31.7 | 18.9 | 1.6 | 29.7 | 6.0 | 26.5 | 19.6 | 11.3 | 5.5 |
| Layout D-Div | 41.6 | 19.7 | 52.1 | 6.9 | 16.6 | 28.1 | 8.1 | 18.6 | 11.0 | 24.5 | 11.9 |
| Layout D-Div | 43.3 | 10.7 | 37.9 | 5.6 | 9.5 | 25.4 | 12.7 | 26.2 | 12.0 | 32.6 | 11.2 |
| Layout C-Div | 8.0 | 2.2 | 18.9 | 26.9 | 3.7 | 7.9 | 12.4 | 0.6 | 9.8 | 21.4 | 21.4 |
| Layout C-Div | 14.1 | 6.8 | 24.2 | 9.9 | 15.9 | 17.5 | 9.9 | 5.9 | 12.3 | 18.7 | 28.6 |
| Layout C-Div | 11.4 | 9.9 | 29.0 | 22.1 | 21.2 | 12.3 | 13.5 | 9.8 | 6.6 | 9.3 | 27.6 |

Set 4 >> Position 4

| | 1 | 2 | 3 | 4 | 5 | 6 | 7 | 8 | 9 | 10 | 11 |
|--------------|------|------|------|------|------|------|------|------|------|------|------|
| Layout H-Div | 11.7 | 2.7 | 16.4 | 8.3 | 13.2 | 16.2 | 8.2 | 8.6 | 9.4 | 19.2 | 14.6 |
| Layout H-Div | 13.2 | 1.5 | 15.4 | 10.2 | 11.4 | 12.5 | 8.7 | 11.7 | 15.1 | 27.1 | 22.1 |
| Layout H-Div | 12.5 | 6.4 | 11.3 | 3.8 | 14.4 | 10.8 | 7.0 | 16.0 | 15.5 | 21.8 | 16.0 |
| Layout V-Div | 13.1 | 12.5 | 19.5 | 21.5 | 11.6 | 10.9 | 15.6 | 28.4 | 18.2 | 29.8 | 17.5 |
| Layout V-Div | 18.5 | 8.4 | 18.7 | 10.5 | 16.2 | 6.3 | 14.4 | 19.9 | 21.2 | 28.6 | 19.1 |
| Layout V-Div | 18.9 | 9.4 | 14.3 | 7.7 | 15.3 | 11.1 | 11.5 | 17.0 | 13.4 | 26.0 | 13.1 |
| Layout D-Div | 25.5 | 2.5 | 5.6 | 34.6 | 8.4 | 22.3 | 6.8 | 7.6 | 5.2 | 24.6 | 13.5 |
| Layout D-Div | 25.1 | 10.2 | 8.9 | 35.5 | 3.4 | 23.4 | 14.1 | 6.8 | 6.9 | 28.7 | 16.9 |
| Layout D-Div | 27.6 | 10.3 | 6.2 | 35.4 | 4.1 | 22.0 | 7.6 | 6.7 | 8.3 | 27.9 | 17.7 |
| Layout C-Div | 19.7 | 15.5 | 6.1 | 34.2 | 8.2 | 28.0 | 24.0 | 7.7 | 19.5 | 7.7 | 13.3 |
| Layout C-Div | 20.3 | 25.6 | 21.5 | 22.9 | 19.9 | 34.9 | 52.9 | 8.1 | 9.5 | 7.7 | 13.9 |
| Layout C-Div | 15.6 | 23.2 | 9.0 | 32.6 | 10.0 | 32.4 | 63.6 | 6.8 | 4.6 | 17.2 | 20.6 |

Set 4 >> Position 4 (Continued)

| | 12 | 13 | 14 | 15 | 16 | 17 | 18 | 19 | 20 | 21 | 22 |
|--------------|------|------|------|------|------|------|------|------|------|------|------|
| Layout H-Div | 12.0 | 7.5 | 11.0 | 6.7 | 5.5 | 18.1 | 10.1 | 8.7 | 8.7 | 6.6 | 11.7 |
| Layout H-Div | 27.4 | 10.1 | 19.6 | 8.5 | 10.8 | 27.1 | 8.3 | 10.1 | 10.5 | 5.8 | 7.9 |
| Layout H-Div | 22.0 | 9.5 | 18.3 | 6.6 | 13.3 | 22.7 | 10.6 | 14.1 | 13.1 | 5.7 | 12.1 |
| Layout V-Div | 26.4 | 16.3 | 18.5 | 8.2 | 7.8 | 27.9 | 7.2 | 7.9 | 25.1 | 3.6 | 13.7 |
| Layout V-Div | 23.6 | 25.4 | 29.8 | 10.0 | 12.5 | 30.9 | 16.3 | 7.1 | 17.6 | 7.0 | 10.2 |
| Layout V-Div | 16.9 | 13.6 | 31.1 | 8.3 | 7.4 | 23.8 | 18.9 | 12.1 | 6.9 | 11.7 | 14.2 |
| Layout D-Div | 38.4 | 13.7 | 14.9 | 10.2 | 14.0 | 32.4 | 15.5 | 5.3 | 9.0 | 17.0 | 43.0 |
| Layout D-Div | 23.6 | 17.2 | 16.0 | 23.1 | 23.4 | 34.6 | 19.8 | 13.7 | 7.2 | 4.7 | 17.4 |
| Layout D-Div | 34.7 | 15.6 | 29.3 | 10.3 | 24.8 | 43.1 | 22.9 | 17.6 | 12.4 | 5.1 | 33.0 |
| Layout C-Div | 11.2 | 5.7 | 4.8 | 35.2 | 8.2 | 20.7 | 2.9 | 23.9 | 13.1 | 16.8 | 9.4 |
| Layout C-Div | 15.0 | 5.1 | 10.4 | 17.7 | 3.7 | 15.3 | 11.4 | 21.6 | 15.2 | 18.0 | 11.3 |
| Layout C-Div | 21.8 | 2.2 | 2.6 | 8.4 | 4.0 | 16.6 | 2.9 | 20.7 | 27.8 | 30.3 | 7.1 |

Appendix 7 Data on the distance error from Experiment 2

The Un-1 layout in a unified or simultaneous presentation mode

| | 1 | 2 | 3 | 4 | 5 | 6 | 7 | 8 | 9 | 10 | 11 |
|------------|------|------|------|------|------|------|------|------|------|------|------|
| Position 1 | 17.1 | 16.2 | 4.8 | 3.1 | 0.9 | 9.7 | 10.8 | 7.9 | 6.6 | 13.2 | 12.9 |
| Position 1 | 17.3 | 11.8 | 9.8 | 2.8 | 0.9 | 16.1 | 10.7 | 11.1 | 9.6 | 22.7 | 7.1 |
| Position 1 | 16.7 | 16.0 | 16.6 | 3.4 | 3.3 | 14.1 | 15.1 | 9.0 | 8.1 | 21.4 | 10.5 |
| Position 2 | 12.2 | 13.2 | 12.2 | 17.8 | 10.0 | 14.3 | 19.8 | 4.0 | 28.1 | 8.2 | 4.5 |
| Position 2 | 14.0 | 9.2 | 14.1 | 13.7 | 12.2 | 16.5 | 54.7 | 4.3 | 31.9 | 15.4 | 3.3 |
| Position 2 | 14.1 | 10.7 | 17.6 | 9.1 | 12.4 | 21.1 | 26.2 | 11.1 | 30.0 | 8.2 | 4.4 |
| Position 3 | 7.5 | 15.9 | 5.1 | 12.4 | 5.2 | 8.1 | 16.7 | 5.5 | 17.7 | 13.0 | 11.5 |
| Position 3 | 5.0 | 10.8 | 14.2 | 11.4 | 4.5 | 9.0 | 19.7 | 11.1 | 22.4 | 21.6 | 27.4 |
| Position 3 | 3.9 | 12.0 | 14.3 | 29.7 | 6.5 | 10.1 | 35.5 | 6.8 | 23.4 | 10.0 | 8.3 |
| Position 4 | 15.3 | 30.6 | 8.1 | 7.6 | 7.7 | 13.7 | 69.5 | 3.6 | 11.6 | 6.7 | 12.4 |
| Position 4 | 12.8 | 18.6 | 10.4 | 4.2 | 6.2 | 11.1 | 65.6 | 2.9 | 15.8 | 5.3 | 17.0 |
| Position 4 | 13.0 | 19.1 | 13.0 | 5.2 | 9.8 | 7.7 | 31.9 | 3.8 | 14.2 | 7.0 | 17.9 |

The Un-1 layout in a unified or simultaneous presentation mode(continued)

| | 12 | 13 | 14 | 15 | 16 | 17 | 18 | 19 | 20 | 21 | 22 |
|------------|------|------|------|------|------|------|------|------|------|------|------|
| Position 1 | 18.7 | 4.1 | 13.8 | 9.3 | 5.2 | 10.6 | 16.8 | 19.7 | 4.9 | 12.5 | 6.5 |
| Position 1 | 25.3 | 9.3 | 18.8 | 4.4 | 4.8 | 19.9 | 23.0 | 11.6 | 6.8 | 15.0 | 10.3 |
| Position 1 | 33.8 | 8.6 | 21.6 | 11.2 | 7.9 | 16.3 | 21.9 | 25.6 | 4.4 | 18.6 | 14.1 |
| Position 2 | 14.0 | 20.3 | 20.1 | 8.8 | 10.0 | 5.8 | 15.5 | 23.2 | 14.4 | 8.1 | 15.9 |
| Position 2 | 13.3 | 25.7 | 14.7 | 13.3 | 16.5 | 19.2 | 14.1 | 23.2 | 12.6 | 11.4 | 22.6 |
| Position 2 | 11.8 | 19.7 | 17.4 | 18.6 | 21.5 | 16.6 | 20.5 | 23.3 | 7.8 | 5.7 | 21.9 |
| Position 3 | 22.9 | 3.5 | 3.2 | 14.4 | 14.0 | 12.4 | 12.4 | 12.9 | 8.6 | 18.5 | 7.5 |
| Position 3 | 24.1 | 19.7 | 9.7 | 15.5 | 16.9 | 15.5 | 9.4 | 10.2 | 9.4 | 13.9 | 4.0 |
| Position 3 | 21.3 | 13.3 | 6.9 | 18.1 | 17.9 | 11.7 | 12.2 | 5.5 | 6.4 | 14.5 | 13.0 |
| Position 4 | 24.4 | 10.1 | 20.3 | 25.2 | 8.9 | 7.9 | 1.9 | 14.8 | 6.4 | 9.0 | 5.3 |
| Position 4 | 29.4 | 19.6 | 13.2 | 18.2 | 19.7 | 6.6 | 6.9 | 18.2 | 12.5 | 9.1 | 11.3 |
| Position 4 | 33.4 | 25.4 | 10.1 | 20.0 | 20.7 | 15.0 | 4.5 | 15.5 | 9.1 | 17.6 | 15.1 |

The Un-2 layout in a unified or simultaneous presentation mode

| | 1 | 2 | 3 | 4 | 5 | 6 | 7 | 8 | 9 | 10 | 11 |
|------------|------|------|------|------|------|------|------|------|------|------|------|
| Position 1 | 7.6 | 22.0 | 4.4 | 5.4 | 9.6 | 23.2 | 12.6 | 5.3 | 20.7 | 12.2 | 2.2 |
| Position 1 | 3.8 | 16.9 | 9.6 | 4.2 | 10.0 | 26.7 | 27.5 | 1.8 | 22.7 | 7.7 | 6.0 |
| Position 1 | 8.4 | 26.3 | 7.3 | 10.9 | 6.0 | 29.1 | 32.6 | 8.8 | 16.2 | 17.2 | 1.2 |
| Position 2 | 7.8 | 21.4 | 12.3 | 3.1 | 8.0 | 0.7 | 5.5 | 9.6 | 16.0 | 16.9 | 3.6 |
| Position 2 | 3.2 | 24.9 | 11.2 | 11.0 | 5.3 | 4.0 | 11.0 | 3.0 | 14.5 | 12.2 | 12.6 |
| Position 2 | 2.9 | 20.9 | 14.0 | 3.9 | 2.3 | 3.3 | 5.3 | 9.8 | 9.2 | 17.5 | 8.8 |
| Position 3 | 15.3 | 17.9 | 7.6 | 8.7 | 14.4 | 14.6 | 5.4 | 45.6 | 10.2 | 9.6 | 11.5 |
| Position 3 | 19.1 | 25.7 | 4.2 | 7.0 | 11.9 | 19.4 | 4.1 | 52.1 | 10.4 | 15.0 | 19.0 |
| Position 3 | 17.7 | 21.5 | 0.6 | 1.2 | 17.3 | 17.7 | 3.6 | 49.1 | 13.4 | 12.5 | 14.1 |
| Position 4 | 2.3 | 4.7 | 6.2 | 6.7 | 16.3 | 5.4 | 14.2 | 28.0 | 13.1 | 4.7 | 5.3 |
| Position 4 | 3.6 | 18.7 | 5.6 | 9.4 | 8.2 | 4.7 | 22.6 | 27.9 | 9.0 | 6.2 | 6.1 |
| Position 4 | 0.4 | 30.9 | 5.7 | 14.5 | 11.6 | 6.9 | 4.1 | 29.1 | 12.1 | 2.8 | 9.5 |

The Un-2 layout in a unified or simultaneous presentation mode(continued)

| | 12 | 13 | 14 | 15 | 16 | 17 | 18 | 19 | 20 | 21 | 22 |
|------------|------|------|------|------|------|------|------|------|------|------|------|
| Position 1 | 18.1 | 14.4 | 11.0 | 8.6 | 6.8 | 7.4 | 12.2 | 10.1 | 9.7 | 8.4 | 4.8 |
| Position 1 | 22.8 | 14.8 | 13.5 | 3.9 | 15.2 | 11.5 | 16.6 | 19.7 | 12.3 | 8.2 | 5.2 |
| Position 1 | 21.2 | 9.2 | 15.6 | 10.6 | 14.7 | 11.3 | 12.4 | 26.6 | 14.6 | 8.7 | 9.2 |
| Position 2 | 8.7 | 5.9 | 6.2 | 9.8 | 7.4 | 9.3 | 9.9 | 7.5 | 9.7 | 14.2 | 19.8 |
| Position 2 | 9.8 | 10.3 | 9.9 | 13.4 | 2.2 | 25.5 | 10.1 | 8.1 | 18.2 | 5.6 | 15.1 |
| Position 2 | 5.6 | 12.7 | 11.1 | 22.6 | 5.7 | 20.7 | 12.8 | 12.3 | 14.0 | 14.5 | 4.5 |
| Position 3 | 15.9 | 18.0 | 19.1 | 14.5 | 7.0 | 6.2 | 8.8 | 16.3 | 5.5 | 8.3 | 18.7 |
| Position 3 | 20.4 | 34.4 | 35.0 | 12.2 | 14.6 | 17.3 | 12.3 | 13.5 | 9.2 | 8.8 | 17.3 |
| Position 3 | 18.5 | 29.8 | 38.0 | 13.7 | 11.5 | 11.6 | 13.4 | 17.0 | 8.8 | 16.6 | 17.2 |
| Position 4 | 7.3 | 16.5 | 10.7 | 11.0 | 12.8 | 17.1 | 6.5 | 10.9 | 21.6 | 17.0 | 12.2 |
| Position 4 | 9.1 | 20.1 | 13.9 | 10.3 | 5.6 | 15.6 | 6.3 | 7.3 | 19.8 | 18.3 | 9.7 |
| Position 4 | 7.5 | 20.8 | 13.5 | 14.6 | 11.3 | 22.8 | 9.6 | 10.0 | 20.2 | 21.4 | 11.0 |

Layout H

| | 1 | 2 | 3 | 4 | 5 | 6 | 7 | 8 | 9 | 10 | 11 |
|----------|-----|------|------|------|-----|------|------|------|-----|------|------|
| Button 1 | 3.5 | 11.2 | 7.6 | 6.8 | 4.5 | 4.7 | 2.3 | 11.2 | 2.6 | 13.9 | 7.2 |
| Button 1 | 5.8 | 13.8 | 7.7 | 7.2 | 7.5 | 4.0 | 2.9 | 14.2 | 5.1 | 11.4 | 8.0 |
| Button 1 | 6.8 | 12.4 | 6.7 | 6.4 | 4.1 | 10.1 | 2.7 | 9.6 | 4.9 | 11.1 | 7.4 |
| Button 2 | 4.9 | 13.4 | 3.0 | 4.4 | 1.5 | 10.6 | 3.6 | 19.6 | 2.8 | 16.7 | 10.2 |
| Button 2 | 3.1 | 11.5 | 14.1 | 6.8 | 9.8 | 8.9 | 13.4 | 1.4 | 3.8 | 5.6 | 7.0 |
| Button 2 | 8.0 | 10.5 | 7.0 | 7.8 | 1.6 | 5.6 | 3.6 | 2.9 | 9.7 | 5.7 | 3.7 |
| Button 3 | 6.0 | 14.3 | 6.2 | 9.7 | 4.9 | 11.0 | 2.4 | 13.3 | 3.2 | 9.9 | 8.9 |
| Button 3 | 4.4 | 15.0 | 16.2 | 11.5 | 6.8 | 8.2 | 5.3 | 7.5 | 6.6 | 10.0 | 7.1 |
| Button 3 | 2.6 | 13.3 | 8.0 | 10.8 | 7.6 | 8.8 | 4.3 | 7.9 | 2.2 | 15.3 | 9.3 |
| Button 4 | 5.4 | 13.5 | 6.2 | 7.0 | 7.6 | 1.2 | 2.0 | 4.6 | 2.0 | 6.3 | 8.2 |
| Button 4 | 6.3 | 13.2 | 12.1 | 4.6 | 7.0 | 3.7 | 4.5 | 6.6 | 3.7 | 3.2 | 9.0 |
| Button 4 | 9.4 | 14.3 | 14.0 | 5.9 | 3.7 | 6.3 | 6.6 | 5.8 | 4.3 | 3.6 | 8.6 |

Layout H (continued)

| | 12 | 13 | 14 | 15 | 16 | 17 | 18 | 19 | 20 | 21 | 22 |
|----------|------|------|------|-----|------|------|------|------|-----|------|------|
| Button 1 | 8.7 | 4.3 | 12.7 | 5.8 | 6.4 | 4.7 | 9.8 | 6.3 | 2.0 | 3.1 | 4.0 |
| Button 1 | 4.0 | 5.9 | 13.9 | 6.9 | 6.4 | 11.3 | 11.7 | 12.1 | 6.6 | 4.7 | 2.6 |
| Button 1 | 11.0 | 6.3 | 18.8 | 7.7 | 5.0 | 12.9 | 12.8 | 15.8 | 5.6 | 3.4 | 3.5 |
| Button 2 | 9.2 | 3.3 | 11.4 | 7.8 | 2.4 | 12.3 | 7.1 | 4.4 | 1.5 | 4.2 | 10.9 |
| Button 2 | 11.0 | 5.7 | 17.5 | 6.8 | 7.2 | 13.3 | 1.7 | 5.3 | 2.9 | 0.6 | 12.5 |
| Button 2 | 10.7 | 3.7 | 14.4 | 3.0 | 5.5 | 14.6 | 7.9 | 9.8 | 6.7 | 5.9 | 7.6 |
| Button 3 | 4.8 | 4.7 | 8.9 | 5.0 | 5.9 | 19.2 | 8.4 | 0.5 | 8.7 | 4.7 | 6.5 |
| Button 3 | 19.2 | 2.8 | 10.8 | 2.4 | 6.1 | 13.9 | 3.2 | 1.3 | 2.3 | 12.0 | 5.4 |
| Button 3 | 17.2 | 10.2 | 13.7 | 6.4 | 11.3 | 13.4 | 15.3 | 6.0 | 2.9 | 6.4 | 15.9 |
| Button 4 | 8.5 | 6.7 | 5.7 | 8.0 | 6.3 | 12.3 | 6.4 | 3.0 | 2.3 | 8.2 | 9.2 |
| Button 4 | 7.2 | 4.1 | 6.1 | 8.6 | 1.1 | 17.1 | 3.7 | 4.1 | 6.6 | 7.0 | 7.0 |
| Button 4 | 10.3 | 4.2 | 5.2 | 7.5 | 9.0 | 16.9 | 4.4 | 9.7 | 7.4 | 7.4 | 8.4 |

Layout H-Div

| | 1 | 2 | 3 | 4 | 5 | 6 | 7 | 8 | 9 | 10 | 11 |
|----------|-----|------|------|------|-----|-----|-----|------|------|------|------|
| Button 1 | 2.7 | 9.5 | 9.1 | 7.0 | 4.8 | 2.2 | 6.5 | 18.8 | 6.6 | 13.3 | 6.4 |
| Button 1 | 3.0 | 8.7 | 10.7 | 4.6 | 7.6 | 5.7 | 2.6 | 17.1 | 9.0 | 16.2 | 6.8 |
| Button 1 | 1.8 | 9.9 | 18.0 | 5.5 | 8.7 | 1.5 | 3.7 | 12.4 | 10.3 | 21.2 | 6.2 |
| Button 2 | 5.4 | 6.8 | 2.6 | 9.3 | 8.5 | 8.7 | 6.4 | 11.3 | 9.6 | 15.7 | 5.9 |
| Button 2 | 7.5 | 2.1 | 10.7 | 7.4 | 1.3 | 3.9 | 5.4 | 11.5 | 2.8 | 12.7 | 31.7 |
| Button 2 | 5.5 | 16.8 | 22.1 | 7.8 | 8.9 | 6.0 | 3.0 | 8.8 | 2.0 | 12.1 | 10.1 |
| Button 3 | 4.1 | 11.4 | 13.0 | 3.6 | 3.8 | 5.4 | 5.3 | 5.0 | 3.0 | 7.4 | 3.6 |
| Button 3 | 6.1 | 8.4 | 17.5 | 8.8 | 0.1 | 6.8 | 5.7 | 3.8 | 5.5 | 9.7 | 9.0 |
| Button 3 | 3.3 | 3.2 | 12.7 | 3.5 | 3.3 | 4.0 | 2.2 | 3.1 | 4.1 | 8.3 | 7.1 |
| Button 4 | 4.1 | 5.9 | 8.3 | 3.1 | 3.5 | 2.5 | 4.0 | 4.1 | 3.9 | 9.0 | 6.1 |
| Button 4 | 3.2 | 7.5 | 10.3 | 11.2 | 2.7 | 3.8 | 7.6 | 1.7 | 4.7 | 7.3 | 3.8 |
| Button 4 | 3.6 | 9.4 | 16.4 | 10.0 | 1.9 | 6.6 | 6.4 | 5.2 | 6.7 | 12.6 | 10.0 |

Layout H-Div (continued)

| | 12 | 13 | 14 | 15 | 16 | 17 | 18 | 19 | 20 | 21 | 22 |
|----------|------|-----|------|------|-----|------|------|------|------|------|------|
| Button 1 | 13.0 | 4.8 | 17.8 | 1.0 | 0.5 | 3.1 | 13.1 | 13.1 | 8.7 | 8.6 | 11.5 |
| Button 1 | 9.1 | 4.0 | 22.2 | 8.2 | 4.1 | 6.3 | 10.7 | 20.2 | 10.6 | 2.7 | 4.2 |
| Button 1 | 5.4 | 6.2 | 20.2 | 14.5 | 5.0 | 4.7 | 14.6 | 15.7 | 2.5 | 6.3 | 10.0 |
| Button 2 | 11.1 | 4.8 | 12.4 | 6.8 | 4.6 | 14.2 | 8.5 | 7.6 | 12.5 | 11.6 | 9.6 |
| Button 2 | 18.2 | 7.5 | 15.8 | 5.8 | 3.5 | 4.1 | 2.2 | 16.2 | 17.0 | 4.1 | 12.3 |
| Button 2 | 0.8 | 8.3 | 21.1 | 10.6 | 4.8 | 9.0 | 10.1 | 12.0 | 21.9 | 1.4 | 9.7 |
| Button 3 | 4.7 | 9.1 | 4.3 | 7.8 | 2.8 | 14.0 | 1.6 | 3.6 | 11.1 | 6.6 | 3.3 |
| Button 3 | 10.4 | 6.4 | 4.7 | 6.4 | 1.9 | 15.8 | 4.3 | 10.1 | 11.7 | 1.3 | 7.2 |
| Button 3 | 3.6 | 7.8 | 9.2 | 2.9 | 2.6 | 14.0 | 6.8 | 7.1 | 10.1 | 6.1 | 9.3 |
| Button 4 | 7.2 | 7.5 | 3.2 | 7.6 | 2.8 | 19.3 | 5.9 | 4.1 | 11.6 | 3.0 | 1.8 |
| Button 4 | 1.7 | 4.6 | 1.8 | 3.8 | 2.9 | 13.4 | 6.2 | 5.7 | 8.5 | 5.3 | 3.7 |
| Button 4 | 3.3 | 4.7 | 5.7 | 7.5 | 3.3 | 13.5 | 6.7 | 5.6 | 12.3 | 2.4 | 6.0 |

Layout VL

| | 1 | 2 | 3 | 4 | 5 | 6 | 7 | 8 | 9 | 10 | 11 |
|----------|------|------|------|------|------|------|------|-----|------|------|------|
| Button 1 | 4.6 | 12.6 | 12.7 | 6.0 | 3.3 | 2.7 | 13.9 | 2.4 | 15.0 | 12.5 | 3.9 |
| Button 1 | 4.0 | 5.9 | 21.0 | 3.5 | 5.5 | 21.3 | 11.9 | 3.7 | 10.0 | 10.7 | 3.8 |
| Button 1 | 2.5 | 1.6 | 17.2 | 5.3 | 10.3 | 5.6 | 14.7 | 8.6 | 10.9 | 14.5 | 4.9 |
| Button 2 | 3.8 | 15.3 | 15.1 | 6.8 | 13.9 | 4.1 | 6.5 | 2.0 | 10.2 | 12.7 | 6.2 |
| Button 2 | 10.0 | 12.0 | 15.1 | 9.7 | 4.3 | 10.6 | 1.5 | 8.7 | 1.5 | 15.5 | 12.5 |
| Button 2 | 4.2 | 8.8 | 14.0 | 5.0 | 3.7 | 13.6 | 13.5 | 8.4 | 5.8 | 13.7 | 7.3 |
| Button 3 | 3.3 | 20.3 | 13.9 | 6.8 | 4.4 | 2.0 | 2.5 | 3.5 | 2.2 | 13.8 | 6.1 |
| Button 3 | 8.0 | 13.7 | 9.5 | 14.5 | 6.2 | 10.9 | 1.0 | 6.6 | 5.9 | 16.0 | 14.9 |
| Button 3 | 3.0 | 7.3 | 11.4 | 6.8 | 16.7 | 16.1 | 7.8 | 6.8 | 12.2 | 13.8 | 7.0 |
| Button 4 | 5.7 | 16.9 | 7.6 | 1.2 | 4.2 | 5.8 | 2.0 | 4.5 | 7.7 | 13.0 | 13.2 |
| Button 4 | 5.8 | 13.6 | 9.7 | 10.2 | 6.0 | 8.5 | 5.2 | 6.1 | 1.7 | 16.3 | 13.3 |
| Button 4 | 10.5 | 16.6 | 10.6 | 2.0 | 4.0 | 12.9 | 7.8 | 4.5 | 4.5 | 17.2 | 11.3 |

Layout VL (continued)

| | 12 | 13 | 14 | 15 | 16 | 17 | 18 | 19 | 20 | 21 | 22 |
|----------|------|------|------|------|------|------|------|------|------|------|------|
| Button 1 | 7.0 | 2.6 | 11.4 | 17.3 | 6.2 | 10.0 | 4.2 | 8.1 | 3.7 | 11.0 | 9.7 |
| Button 1 | 14.7 | 5.5 | 13.1 | 8.7 | 5.8 | 7.6 | 11.3 | 12.6 | 7.7 | 9.6 | 7.7 |
| Button 1 | 11.0 | 8.4 | 13.3 | 7.4 | 3.1 | 8.6 | 17.3 | 19.4 | 3.8 | 5.1 | 11.3 |
| Button 2 | 8.9 | 2.0 | 7.2 | 16.0 | 10.6 | 3.0 | 13.0 | 0.3 | 4.4 | 15.1 | 12.1 |
| Button 2 | 13.0 | 6.4 | 16.7 | 7.6 | 16.1 | 15.9 | 16.4 | 8.9 | 17.8 | 13.9 | 8.7 |
| Button 2 | 9.8 | 13.1 | 10.8 | 8.4 | 2.7 | 13.3 | 17.7 | 11.4 | 20.5 | 23.7 | 16.1 |
| Button 3 | 15.3 | 1.0 | 13.6 | 6.6 | 13.9 | 4.6 | 7.4 | 9.0 | 9.2 | 11.3 | 7.8 |
| Button 3 | 13.5 | 7.8 | 13.8 | 16.5 | 4.6 | 26.1 | 19.3 | 9.0 | 25.2 | 6.7 | 11.8 |
| Button 3 | 9.2 | 7.7 | 8.4 | 9.4 | 6.4 | 11.9 | 14.3 | 2.5 | 15.5 | 2.0 | 4.3 |
| Button 4 | 6.5 | 3.0 | 14.3 | 10.6 | 4.2 | 14.8 | 15.8 | 11.2 | 4.7 | 4.5 | 2.8 |
| Button 4 | 16.3 | 6.9 | 13.3 | 14.4 | 4.0 | 19.4 | 22.1 | 3.8 | 6.2 | 9.5 | 6.6 |
| Button 4 | 16.5 | 4.3 | 19.6 | 8.0 | 4.5 | 19.2 | 19.3 | 3.1 | 11.3 | 8.1 | 9.5 |

Layout VR

| | 1 | 2 | 3 | 4 | 5 | 6 | 7 | 8 | 9 | 10 | 11 |
|----------|------|------|------|------|------|------|------|------|------|------|------|
| Button 1 | 8.2 | 12.8 | 6.3 | 5.9 | 8.9 | 9.6 | 3.8 | 17.9 | 17.4 | 8.5 | 4.3 |
| Button 1 | 6.4 | 9.5 | 2.5 | 3.8 | 7.4 | 9.8 | 8.0 | 28.0 | 21.2 | 5.8 | 3.0 |
| Button 1 | 7.4 | 14.4 | 4.0 | 4.0 | 3.4 | 3.5 | 2.4 | 24.6 | 13.7 | 6.7 | 5.1 |
| Button 2 | 9.6 | 13.6 | 11.0 | 0.9 | 3.4 | 12.4 | 4.8 | 15.8 | 10.9 | 13.5 | 7.3 |
| Button 2 | 14.4 | 9.1 | 8.1 | 8.4 | 14.9 | 9.4 | 2.2 | 15.4 | 11.7 | 8.6 | 15.4 |
| Button 2 | 7.3 | 6.9 | 1.3 | 10.1 | 4.6 | 19.6 | 3.8 | 18.8 | 6.3 | 7.7 | 9.0 |
| Button 3 | 6.8 | 15.2 | 5.0 | 5.2 | 1.6 | 15.6 | 4.6 | 18.2 | 8.2 | 10.3 | 4.5 |
| Button 3 | 7.5 | 3.9 | 6.1 | 8.0 | 6.2 | 6.3 | 8.0 | 7.7 | 10.1 | 10.4 | 21.2 |
| Button 3 | 7.3 | 8.4 | 4.5 | 9.2 | 6.3 | 9.5 | 2.9 | 15.6 | 13.8 | 20.4 | 2.1 |
| Button 4 | 5.5 | 10.5 | 7.2 | 4.7 | 0.1 | 12.4 | 1.0 | 13.2 | 7.1 | 3.0 | 9.6 |
| Button 4 | 2.1 | 10.6 | 9.3 | 3.8 | 6.1 | 11.7 | 11.3 | 12.4 | 9.3 | 7.0 | 7.2 |
| Button 4 | 1.5 | 8.0 | 9.3 | 3.8 | 6.2 | 9.6 | 4.9 | 10.8 | 8.6 | 10.4 | 9.3 |

Layout VR (continued)

| | 12 | 13 | 14 | 15 | 16 | 17 | 18 | 19 | 20 | 21 | 22 |
|----------|------|------|------|------|------|------|------|------|------|------|------|
| Button 1 | 6.4 | 3.7 | 5.0 | 23.4 | 3.7 | 3.4 | 5.0 | 18.2 | 3.6 | 5.5 | 6.2 |
| Button 1 | 11.5 | 4.2 | 5.1 | 15.8 | 7.2 | 1.6 | 6.9 | 31.8 | 2.6 | 6.3 | 10.0 |
| Button 1 | 8.7 | 9.4 | 8.9 | 9.7 | 4.6 | 6.9 | 8.8 | 35.6 | 12.9 | 6.3 | 10.8 |
| Button 2 | 8.1 | 3.5 | 1.9 | 29.5 | 6.2 | 4.7 | 11.0 | 14.0 | 3.2 | 5.9 | 11.7 |
| Button 2 | 11.5 | 9.1 | 4.8 | 28.2 | 33.2 | 10.4 | 12.4 | 32.0 | 16.5 | 15.8 | 7.4 |
| Button 2 | 14.0 | 2.8 | 8.2 | 20.7 | 14.3 | 6.5 | 15.7 | 31.3 | 16.8 | 6.0 | 9.5 |
| Button 3 | 14.9 | 4.6 | 6.5 | 24.6 | 5.7 | 5.4 | 16.2 | 9.8 | 2.2 | 4.4 | 10.1 |
| Button 3 | 16.0 | 1.8 | 6.1 | 25.6 | 5.8 | 10.0 | 17.5 | 5.8 | 5.5 | 10.8 | 6.5 |
| Button 3 | 9.4 | 2.7 | 9.5 | 25.5 | 4.7 | 2.8 | 14.3 | 24.6 | 4.3 | 4.6 | 9.7 |
| Button 4 | 5.4 | 10.7 | 8.2 | 21.8 | 5.7 | 4.9 | 19.9 | 11.9 | 4.1 | 7.7 | 8.0 |
| Button 4 | 16.2 | 8.6 | 12.3 | 33.3 | 5.7 | 6.3 | 20.4 | 8.8 | 6.2 | 5.2 | 6.3 |
| Button 4 | 24.6 | 6.4 | 16.7 | 35.5 | 2.0 | 6.5 | 20.2 | 10.6 | 1.3 | 12.5 | 3.8 |

Layout V-Div

| | 1 | 2 | 3 | 4 | 5 | 6 | 7 | 8 | 9 | 10 | 11 |
|----------|------|------|------|------|-----|------|------|------|------|------|------|
| Button 1 | 5.6 | 5.6 | 4.9 | 3.3 | 9.6 | 5.8 | 9.0 | 22.7 | 4.3 | 1.6 | 1.6 |
| Button 1 | 6.6 | 3.6 | 20.8 | 7.8 | 6.0 | 3.5 | 8.1 | 17.7 | 5.9 | 4.1 | 4.8 |
| Button 1 | 12.2 | 8.4 | 23.6 | 3.9 | 7.4 | 2.4 | 11.8 | 21.8 | 7.2 | 2.2 | 1.6 |
| Button 2 | 2.6 | 4.8 | 13.8 | 4.0 | 4.6 | 5.6 | 8.1 | 18.6 | 4.1 | 10.5 | 2.9 |
| Button 2 | 7.3 | 8.9 | 21.7 | 17.6 | 3.3 | 6.9 | 7.7 | 9.8 | 12.3 | 7.6 | 9.5 |
| Button 2 | 9.9 | 7.2 | 25.5 | 7.1 | 5.8 | 7.6 | 8.2 | 17.9 | 14.0 | 3.7 | 4.7 |
| Button 3 | 4.7 | 1.3 | 24.3 | 7.9 | 3.8 | 13.7 | 5.6 | 7.2 | 13.6 | 15.6 | 6.7 |
| Button 3 | 2.4 | 17.5 | 23.2 | 7.1 | 9.6 | 3.6 | 3.3 | 6.8 | 3.9 | 11.8 | 18.4 |
| Button 3 | 2.1 | 7.2 | 33.3 | 6.6 | 2.4 | 3.1 | 9.2 | 7.7 | 5.1 | 9.7 | 10.5 |
| Button 4 | 3.8 | 4.6 | 22.6 | 11.2 | 7.3 | 3.0 | 6.9 | 1.9 | 2.5 | 10.7 | 6.3 |
| Button 4 | 4.8 | 18.1 | 28.2 | 8.4 | 6.1 | 4.9 | 4.7 | 1.7 | 8.6 | 7.6 | 15.6 |
| Button 4 | 3.6 | 13.5 | 25.1 | 12.7 | 7.7 | 6.1 | 6.7 | 4.4 | 8.2 | 10.2 | 9.9 |

Layout V-Div (continued)

| | 12 | 13 | 14 | 15 | 16 | 17 | 18 | 19 | 20 | 21 | 22 |
|----------|------|------|------|------|------|------|------|------|------|------|------|
| Button 1 | 6.4 | 4.3 | 8.6 | 12.5 | 11.9 | 8.2 | 6.1 | 7.3 | 8.1 | 9.6 | 9.7 |
| Button 1 | 9.5 | 5.3 | 7.4 | 10.0 | 13.9 | 11.5 | 7.5 | 13.1 | 5.2 | 11.4 | 8.1 |
| Button 1 | 12.2 | 4.7 | 9.6 | 8.8 | 13.8 | 9.6 | 18.6 | 20.0 | 5.5 | 8.0 | 11.3 |
| Button 2 | 8.0 | 2.0 | 7.2 | 17.6 | 5.4 | 17.9 | 7.9 | 7.2 | 17.0 | 11.8 | 10.3 |
| Button 2 | 13.8 | 6.5 | 8.7 | 7.8 | 19.8 | 14.2 | 9.0 | 8.0 | 9.2 | 13.2 | 9.2 |
| Button 2 | 19.8 | 4.6 | 5.5 | 11.5 | 19.7 | 15.9 | 8.8 | 22.5 | 7.6 | 10.7 | 7.0 |
| Button 3 | 6.8 | 11.6 | 12.5 | 18.1 | 10.6 | 16.0 | 5.8 | 10.4 | 7.0 | 14.0 | 9.7 |
| Button 3 | 24.6 | 19.9 | 16.3 | 18.1 | 19.6 | 12.0 | 6.7 | 1.5 | 5.6 | 13.1 | 9.5 |
| Button 3 | 17.0 | 12.4 | 16.6 | 15.7 | 10.1 | 16.5 | 1.6 | 8.4 | 4.9 | 10.3 | 11.1 |
| Button 4 | 4.1 | 12.4 | 16.6 | 15.7 | 7.0 | 6.8 | 2.0 | 6.5 | 1.5 | 13.7 | 6.9 |
| Button 4 | 9.0 | 24.3 | 21.9 | 16.3 | 8.0 | 13.6 | 4.6 | 9.6 | 3.9 | 16.6 | 11.8 |
| Button 4 | 20.8 | 22.6 | 20.7 | 15.2 | 15.6 | 12.0 | 9.3 | 4.8 | | 12.8 | 13.2 |

Layout D

| | 1 | 2 | 3 | 4 | 5 | 6 | 7 | 8 | 9 | 10 | 11 |
|----------|------|------|------|------|-----|------|------|------|------|------|------|
| Button 1 | 13.3 | 3.4 | 3.5 | 6.6 | 8.5 | 12.9 | 5.5 | 4.5 | 6.0 | 12.9 | 4.5 |
| Button 1 | 16.8 | 8.0 | 5.3 | 6.5 | 6.3 | 13.7 | 10.9 | 20.6 | 8.3 | 6.2 | 0.4 |
| Button 1 | 10.5 | 11.7 | 6.9 | 11.1 | 8.3 | 9.7 | 12.6 | 19.6 | 7.1 | 11.6 | 4.7 |
| Button 2 | 13.8 | 12.9 | 4.1 | 6.4 | 1.9 | 18.2 | 4.8 | 8.8 | 8.6 | 12.7 | 11.2 |
| Button 2 | 15.8 | 7.5 | 4.9 | 3.3 | 3.0 | 16.9 | 7.9 | 10.0 | 5.5 | 10.2 | 5.6 |
| Button 2 | 11.4 | 6.0 | 4.1 | 7.4 | 6.6 | 11.8 | 13.7 | 13.6 | 13.9 | 4.8 | 13.4 |
| Button 3 | 6.9 | 6.1 | 8.2 | 5.3 | 3.0 | 23.3 | 5.8 | 14.1 | 4.9 | 13.9 | 7.3 |
| Button 3 | 4.3 | 10.3 | 15.4 | 0.8 | 4.5 | 10.7 | 6.6 | 4.9 | 7.5 | 5.1 | 10.7 |
| Button 3 | 21.3 | 6.2 | 15.3 | 9.6 | 6.4 | 12.5 | 2.5 | 14.2 | 14.2 | 18.0 | 10.5 |
| Button 4 | 7.9 | 3.6 | 9.6 | 5.7 | 8.9 | 17.0 | 3.1 | 11.8 | 7.9 | 12.3 | 6.5 |
| Button 4 | 8.8 | 5.6 | 11.1 | 3.4 | 8.8 | 9.8 | 6.6 | 8.3 | 6.1 | 11.0 | 5.9 |
| Button 4 | 9.5 | 16.0 | 13.4 | 1.8 | 5.1 | 6.9 | 3.8 | 5.2 | 8.9 | 7.6 | 12.0 |

Layout D (continued)

| | 12 | 13 | 14 | 15 | 16 | 17 | 18 | 19 | 20 | 21 | 22 |
|----------|------|------|------|------|------|------|------|------|------|------|------|
| Button 1 | 8.2 | 20.1 | 9.5 | 6.1 | 13.2 | 13.7 | 7.0 | 12.1 | 7.9 | 17.8 | 7.8 |
| Button 1 | 7.1 | 20.6 | 15.9 | 14.2 | 7.7 | 14.8 | 8.9 | 6.0 | 9.7 | 9.8 | 5.3 |
| Button 1 | 9.3 | 20.2 | 23.4 | 11.9 | 13.6 | 13.8 | 14.4 | 12.3 | 6.9 | 2.1 | 7.8 |
| Button 2 | 11.6 | 18.0 | 6.7 | 9.0 | 15.1 | 19.7 | 8.2 | 15.2 | 4.7 | 12.9 | 6.6 |
| Button 2 | 9.0 | 14.8 | 11.5 | 13.5 | 17.8 | 19.4 | 5.0 | 12.9 | 12.5 | 16.4 | 2.6 |
| Button 2 | 13.4 | 28.6 | 15.6 | 15.8 | 9.1 | 22.4 | 7.5 | 14.5 | 20.9 | 8.2 | 1.4 |
| Button 3 | 10.6 | 24.7 | 4.7 | 19.1 | 13.7 | 22.7 | 8.1 | 14.8 | 21.1 | 10.4 | 13.5 |
| Button 3 | 9.5 | 15.9 | 8.7 | 11.8 | 6.7 | 16.1 | 8.5 | 9.1 | 16.4 | 15.0 | 7.1 |
| Button 3 | 13.4 | 22.8 | 17.0 | 13.5 | 11.4 | 3.4 | 9.7 | 8.8 | 14.1 | 19.1 | 13.3 |
| Button 4 | 15.8 | 15.2 | 2.8 | 13.5 | 7.3 | 6.2 | 3.2 | 4.3 | 13.0 | 15.1 | 10.5 |
| Button 4 | 18.1 | 12.1 | 5.0 | 11.7 | 3.2 | 10.0 | 5.9 | 10.2 | 13.7 | 15.9 | 9.1 |
| Button 4 | 18.7 | 11.5 | 1.0 | 12.2 | 8.0 | 7.7 | 6.7 | 12.2 | 12.5 | 12.9 | 6.4 |

Layout D-Div

| | 1 | 2 | 3 | 4 | 5 | 6 | 7 | 8 | 9 | 10 | 11 |
|----------|------|------|------|------|------|------|------|------|------|------|------|
| Button 1 | 9.3 | 16.4 | 4.3 | 9.1 | 3.0 | 6.5 | 10.6 | 7.9 | 8.9 | 3.9 | 0.9 |
| Button 1 | 13.3 | 21.9 | 4.5 | 3.1 | 4.6 | 3.4 | 8.2 | 14.2 | 10.7 | 3.4 | 2.0 |
| Button 1 | 12.4 | 15.6 | 6.9 | 8.1 | 5.4 | 7.9 | 5.6 | 24.2 | 16.1 | 10.9 | 5.7 |
| Button 2 | 3.7 | 18.8 | 11.7 | 10.4 | 11.9 | 5.9 | 1.4 | 4.9 | 7.0 | 1.3 | 5.7 |
| Button 2 | 5.1 | 24.2 | 8.9 | 6.3 | 4.0 | 7.6 | 10.0 | 11.8 | 9.4 | 9.2 | 7.4 |
| Button 2 | 1.7 | 14.7 | 6.5 | 6.8 | 3.9 | 4.1 | 14.2 | 19.5 | 17.2 | 9.8 | 2.5 |
| Button 3 | 2.2 | 9.5 | 17.4 | 8.9 | 11.8 | 6.8 | 26.3 | 2.4 | 5.9 | 9.2 | 6.2 |
| Button 3 | 2.5 | 12.1 | 9.8 | 2.1 | 4.0 | 8.0 | 12.5 | 11.0 | 4.0 | 3.3 | 11.9 |
| Button 3 | 7.3 | 5.0 | 10.7 | 3.3 | 4.5 | 8.7 | 16.4 | 13.2 | 1.7 | 11.8 | 6.9 |
| Button 4 | 8.1 | 9.3 | 17.8 | 10.9 | 5.0 | 14.1 | 10.4 | 11.6 | 10.1 | 11.2 | 2.8 |
| Button 4 | 2.0 | 5.5 | 8.7 | 5.9 | 10.8 | 6.6 | 15.5 | 14.5 | 6.4 | 7.5 | 5.6 |
| Button 4 | 8.0 | 7.1 | 11.2 | 3.4 | 7.3 | 10.6 | 13.4 | 11.8 | 8.4 | 5.1 | 2.7 |

Layout D-Div (continued)

| | 12 | 13 | 14 | 15 | 16 | 17 | 18 | 19 | 20 | 21 | 22 |
|----------|------|------|------|------|------|------|------|------|------|------|------|
| Button 1 | 5.6 | 5.6 | 14.3 | 14.4 | 7.6 | 3.7 | 17.3 | 13.6 | 10.8 | 23.3 | 8.9 |
| Button 1 | 4.5 | 12.0 | 10.7 | 17.1 | 2.5 | 14.3 | 13.9 | 5.9 | 11.1 | 6.6 | 4.2 |
| Button 1 | 8.3 | 6.5 | 18.5 | 23.3 | 2.0 | 16.4 | 21.4 | 2.3 | 6.7 | 6.9 | 6.4 |
| Button 2 | 10.8 | 13.1 | 9.4 | 9.5 | 7.5 | 10.7 | 12.5 | 11.2 | 12.5 | 26.6 | 12.7 |
| Button 2 | 5.1 | 15.9 | 17.1 | 13.7 | 5.0 | 14.5 | 21.8 | 10.4 | 11.5 | 9.4 | 5.2 |
| Button 2 | 18.6 | 12.0 | 20.0 | 18.8 | 5.7 | 21.2 | 13.8 | 16.5 | 13.3 | 25.8 | 4.1 |
| Button 3 | 13.7 | 15.6 | 4.7 | 3.9 | 3.7 | 1.3 | 6.3 | 21.1 | 7.1 | 17.1 | 8.1 |
| Button 3 | 22.3 | 18.2 | 5.2 | 9.4 | 2.4 | 14.0 | 2.4 | 10.7 | 10.7 | 6.4 | 4.5 |
| Button 3 | 13.5 | 12.4 | 17.2 | 10.6 | 10.3 | 6.6 | 4.1 | 1.9 | 14.1 | 9.1 | 8.7 |
| Button 4 | 9.5 | 3.1 | 6.8 | 3.6 | 8.9 | 5.4 | 3.7 | 17.4 | 12.8 | 11.0 | 9.6 |
| Button 4 | 18.9 | 22.6 | 3.1 | 5.4 | 7.8 | 1.0 | 4.0 | 9.9 | 21.5 | 8.6 | 5.8 |
| Button 4 | 19.4 | 17.7 | 4.1 | 5.1 | 4.4 | 6.9 | 6.6 | 10.9 | 14.9 | 10.0 | 3.1 |

Layout C

| | 1 | 2 | 3 | 4 | 5 | 6 | 7 | 8 | 9 | 10 | 11 |
|----------|-----|-----|------|------|------|------|------|------|------|------|------|
| Button 1 | 4.3 | 4.1 | 14.6 | 4.7 | 5.8 | 17.0 | 13.7 | 6.8 | 7.7 | 15.0 | 13.9 |
| Button 1 | 6.2 | 5.8 | 9.3 | 8.4 | 12.4 | 14.1 | 16.6 | 8.8 | 14.6 | 11.8 | 16.7 |
| Button 1 | 5.6 | 8.8 | 17.9 | 4.9 | 10.5 | 15.4 | 8.0 | 10.7 | 20.0 | 15.6 | 17.2 |
| Button 2 | 8.7 | 9.4 | 15.4 | 15.0 | 6.6 | 16.9 | 14.5 | 7.6 | 11.5 | 11.5 | 17.1 |
| Button 2 | 7.7 | 4.4 | 13.7 | 9.1 | 12.8 | 10.8 | 16.9 | 3.3 | 14.8 | 19.5 | 1.7 |
| Button 2 | 5.7 | 6.3 | 14.7 | 15.2 | 18.7 | 14.5 | 22.5 | 7.3 | 22.6 | 12.6 | 10.7 |
| Button 3 | 2.1 | 2.2 | 20.4 | 12.7 | 10.0 | 12.6 | 11.7 | 11.9 | 15.9 | 7.1 | 12.7 |
| Button 3 | 4.3 | 3.5 | 12.3 | 13.7 | 9.7 | 5.5 | 10.2 | 3.5 | 21.8 | 9.2 | 5.7 |
| Button 3 | 7.7 | 6.6 | 14.7 | 13.5 | 15.9 | 9.1 | 24.4 | 8.8 | 14.1 | 14.7 | 8.2 |
| Button 4 | 3.3 | 5.6 | 10.2 | 3.8 | 7.7 | 3.2 | 3.5 | 14.9 | 12.3 | 5.9 | 11.0 |
| Button 4 | 4.1 | 6.9 | 13.1 | 5.6 | 10.6 | 10.2 | 14.4 | 15.1 | 13.8 | 11.4 | 9.3 |
| Button 4 | 1.6 | 5.0 | 10.3 | 5.4 | 12.3 | 6.9 | 12.1 | 9.9 | 14.7 | 9.4 | 8.7 |

Layout C (continued)

| | 12 | 13 | 14 | 15 | 16 | 17 | 18 | 19 | 20 | 21 | 22 |
|----------|------|------|------|------|------|------|------|------|------|------|------|
| Button 1 | 8.7 | 7.8 | 13.7 | 9.6 | 5.7 | 2.3 | 12.5 | 17.8 | 3.8 | 8.1 | 9.2 |
| Button 1 | 15.9 | 4.7 | 13.5 | 10.7 | 2.5 | 5.2 | 11.8 | 19.0 | 9.1 | 11.8 | 18.5 |
| Button 1 | 22.6 | 12.9 | 19.1 | 7.5 | 4.9 | 16.1 | 18.5 | 21.9 | 9.7 | 7.5 | 16.8 |
| Button 2 | 7.2 | 3.9 | 23.6 | 13.9 | 6.7 | 11.3 | 14.9 | 20.5 | 6.4 | 8.0 | 9.7 |
| Button 2 | 21.0 | 8.6 | 25.4 | 6.8 | 6.7 | 4.1 | 14.3 | 26.0 | 20.0 | 8.9 | 18.0 |
| Button 2 | 30.7 | 5.0 | 33.7 | 13.8 | 9.8 | 17.6 | 21.3 | 23.7 | 8.2 | 15.2 | 23.2 |
| Button 3 | 7.4 | 5.0 | 33.2 | 14.0 | 9.5 | 10.8 | 12.5 | 21.7 | 7.1 | 16.0 | 9.8 |
| Button 3 | 26.2 | 15.8 | 39.7 | 7.7 | 12.4 | 3.1 | 20.0 | 21.4 | 11.7 | 6.0 | 16.5 |
| Button 3 | 29.7 | 8.2 | 43.9 | 9.9 | 9.1 | 3.9 | 21.5 | 22.0 | 12.8 | 5.3 | 19.4 |
| Button 4 | 10.2 | 7.1 | 30.9 | 13.9 | 3.1 | 15.6 | 15.3 | 13.4 | 7.2 | 10.8 | 8.0 |
| Button 4 | 14.7 | 3.8 | 32.4 | 16.9 | 5.4 | 14.7 | 20.3 | 18.7 | 8.5 | 9.0 | 5.8 |
| Button 4 | 19.5 | 1.8 | 38.6 | 16.6 | 3.1 | 14.3 | 18.8 | 20.5 | 16.2 | 5.6 | 8.0 |

Layout C-Div

| | 1 | 2 | 3 | 4 | 5 | 6 | 7 | 8 | 9 | 10 | 11 |
|----------|------|------|------|------|------|------|------|------|------|------|------|
| Button 1 | 11.5 | 16.7 | 14.6 | 3.5 | 5.1 | 15.9 | 1.0 | 11.1 | 11.5 | 14.4 | 17.3 |
| Button 1 | 12.6 | 12.1 | 9.8 | 3.8 | 1.9 | 23.0 | 5.0 | 12.2 | 8.8 | 15.9 | 20.5 |
| Button 1 | 15.5 | 16.8 | 14.1 | 2.3 | 4.6 | 24.1 | 2.3 | 9.0 | 10.0 | 13.6 | 21.4 |
| Button 2 | 7.9 | 17.0 | 15.4 | 13.9 | 10.1 | 11.5 | 10.4 | 14.3 | 10.8 | 15.3 | 19.2 |
| Button 2 | 23.0 | 22.7 | 7.1 | 2.4 | 8.4 | 19.3 | 4.5 | 10.1 | 8.3 | 13.9 | 16.5 |
| Button 2 | 22.6 | 12.4 | 16.1 | 8.2 | 7.8 | 16.4 | 3.8 | 12.9 | 10.3 | 18.8 | 23.7 |
| Button 3 | 8.6 | 7.4 | 5.6 | 10.4 | 1.8 | 6.8 | 10.7 | 7.9 | 17.6 | 10.2 | 6.9 |
| Button 3 | 20.0 | 2.6 | 6.9 | 9.6 | 5.5 | 11.5 | 2.6 | 7.3 | 18.1 | 6.2 | 8.5 |
| Button 3 | 12.5 | 3.6 | 17.1 | 4.5 | 6.6 | 9.7 | 11.5 | 7.8 | 15.7 | 7.6 | 12.1 |
| Button 4 | 10.2 | 8.7 | 2.3 | 4.5 | 11.4 | 9.1 | 9.9 | 9.5 | 12.6 | 5.5 | 11.1 |
| Button 4 | 9.0 | 3.8 | 2.6 | 4.2 | 10.0 | 5.1 | 6.1 | 11.1 | 16.5 | 1.9 | 10.9 |
| Button 4 | 10.1 | 3.8 | 2.7 | 2.6 | 8.5 | 3.3 | 6.4 | 11.5 | 18.5 | 5.2 | 10.9 |

Layout C-Div (continued)

| | 12 | 13 | 14 | 15 | 16 | 17 | 18 | 19 | 20 | 21 | 22 |
|----------|------|------|------|------|------|------|------|------|------|------|------|
| Button 1 | 10.1 | 9.8 | 21.3 | 6.5 | 17.2 | 13.0 | 12.4 | 23.1 | 9.0 | 8.8 | 8.4 |
| Button 1 | 14.2 | 9.1 | 24.7 | 10.0 | 14.2 | 12.2 | 12.7 | 28.5 | 11.0 | 19.3 | 12.7 |
| Button 1 | 19.6 | 6.4 | 24.7 | 5.5 | 13.3 | 17.1 | 17.4 | 26.8 | 4.6 | 19.7 | 14.8 |
| Button 2 | 9.6 | 15.9 | 28.3 | 16.6 | 18.1 | 8.2 | 16.6 | 20.5 | 19.7 | 20.0 | 16.5 |
| Button 2 | 18.3 | 22.5 | 34.9 | 14.6 | 16.1 | 17.1 | 22.7 | 34.7 | 8.5 | 11.3 | 22.5 |
| Button 2 | 22.4 | 22.3 | 32.7 | 14.5 | 20.0 | 14.7 | 23.3 | 28.2 | 10.3 | 19.8 | 25.4 |
| Button 3 | 13.1 | 4.0 | 40.3 | 5.5 | 16.0 | 3.5 | 15.0 | 24.4 | 8.1 | 9.0 | 28.9 |
| Button 3 | 24.9 | 5.3 | 44.6 | 15.4 | 11.1 | 17.4 | 21.2 | 30.0 | 17.9 | 12.0 | 26.0 |
| Button 3 | 24.8 | 8.7 | 43.3 | 11.8 | 13.5 | 10.7 | 28.3 | 32.0 | 5.3 | 4.3 | 30.2 |
| Button 4 | 13.1 | 1.2 | 44.3 | 11.5 | 14.0 | 12.2 | 15.5 | 19.2 | 4.1 | 5.8 | 26.2 |
| Button 4 | 15.0 | 4.8 | 43.0 | 12.3 | 13.8 | 11.0 | 19.8 | 23.2 | 4.3 | 5.1 | 21.2 |
| Button 4 | 22.0 | 3.3 | 45.8 | 14.9 | 10.7 | 17.9 | 21.1 | 23.3 | 5.1 | 0.5 | 21.0 |

Layout V-Line

| | 1 | 2 | 3 | 4 | 5 | 6 | 7 | 8 | 9 | 10 | 11 |
|--------|------|------|-----|-----|-----|------|------|-----|-----|------|-----|
| Line 1 | 0.6 | 16.5 | 3.0 | 0.5 | 3.8 | 4.5 | 6.3 | 7.0 | 5.2 | 10.3 | 7.3 |
| Line 1 | 0.9 | 13.0 | 0.0 | 4.8 | 1.2 | 7.4 | 6.2 | 3.4 | 7.7 | 13.0 | 6.2 |
| Line 1 | 4.5 | 12.6 | 0.4 | 0.2 | 4.4 | 3.7 | 6.2 | 0.9 | 6.7 | 7.8 | 4.8 |
| Line 2 | 5.5 | 7.7 | 3.6 | 3.6 | 7.6 | 1.1 | 9.7 | 8.4 | 4.5 | 12.7 | 2.1 |
| Line 2 | 5.0 | 6.4 | 2.0 | 0.3 | 1.1 | 0.5 | 4.7 | 1.0 | 1.5 | 11.6 | 8.0 |
| Line 2 | 2.3 | 8.5 | 1.6 | 3.8 | 7.4 | 2.6 | 4.1 | 1.6 | 2.8 | 4.9 | 2.5 |
| Line 3 | 4.0 | 5.7 | 8.1 | 5.2 | 2.8 | 1.0 | 11.0 | 5.8 | 3.1 | 8.5 | 2.0 |
| Line 3 | 12.1 | 6.9 | 2.6 | 0.8 | 7.2 | 0.0 | 3.1 | 1.8 | 0.9 | 5.9 | 0.1 |
| Line 3 | 4.7 | 5.5 | 2.5 | 8.0 | 6.7 | 10.7 | 7.6 | 7.4 | 6.4 | 17.3 | 5.3 |
| Line 4 | 3.2 | 1.3 | 6.6 | 2.4 | 3.4 | 4.4 | 5.1 | 3.6 | 5.0 | 3.6 | 2.7 |
| Line 4 | 1.5 | 2.2 | 7.4 | 2.1 | 1.7 | 4.1 | 3.4 | 1.2 | 4.4 | 2.3 | 2.4 |
| Line 4 | 1.4 | 2.3 | 2.6 | 3.4 | 1.0 | 4.3 | 5.3 | 4.2 | 2.4 | 1.0 | 4.1 |

Layout V-line (continued)

| | 12 | 13 | 14 | 15 | 16 | 17 | 18 | 19 | 20 | 21 | 22 |
|--------|------|------|------|-----|------|------|------|------|------|-----|------|
| Line 1 | 16.0 | 2.4 | 11.4 | 0.8 | 1.4 | 3.2 | 14.8 | 6.2 | 5.9 | 5.5 | 7.5 |
| Line 1 | 20.5 | 3.4 | 13.6 | 5.5 | 0.7 | 3.6 | 10.2 | 16.4 | 0.5 | 1.1 | 5.7 |
| Line 1 | 12.5 | 1.1 | 11.5 | 3.2 | 3.2 | 1.5 | 9.4 | 15.9 | 2.6 | 6.8 | 8.4 |
| Line 2 | 11.7 | 6.7 | 6.7 | 4.7 | 2.3 | 5.5 | 5.3 | 12.1 | 10.3 | 8.3 | 9.4 |
| Line 2 | 14.7 | 0.9 | 1.1 | 4.2 | 7.2 | 1.3 | 8.8 | 9.5 | 3.3 | 4.5 | 4.7 |
| Line 2 | 8.0 | 1.3 | 7.5 | 3.8 | 10.3 | 3.6 | 3.3 | 7.5 | 0.6 | 4.4 | 5.2 |
| Line 3 | 13.2 | 0.4 | 3.6 | 0.2 | 2.1 | 2.2 | 12.0 | 12.2 | 13.7 | 1.9 | 5.5 |
| Line 3 | 8.9 | 9.0 | 0.8 | 0.8 | 15.0 | 8.2 | 8.6 | 6.8 | 4.8 | 1.9 | 10.0 |
| Line 3 | 15.7 | 2.4 | 10.3 | 3.0 | 1.1 | 5.1 | 12.1 | 11.1 | 16.1 | 4.9 | 15.6 |
| Line 4 | 4.3 | 1.2 | 3.3 | 4.4 | 2.9 | 8.3 | 0.1 | 3.3 | 4.7 | 5.4 | 5.4 |
| Line 4 | 5.6 | 10.9 | 0.5 | 5.8 | 3.2 | 12.2 | 3.0 | 5.0 | 6.7 | 2.7 | 5.5 |
| Line 4 | 5.6 | 0.2 | 0.0 | 5.3 | 1.8 | 15.8 | 1.3 | 3.5 | 7.6 | 3.6 | 8.4 |

Layout H-Line

| | 1 | 2 | 3 | 4 | 5 | 6 | 7 | 8 | 9 | 10 | 11 |
|--------|-----|------|------|------|-----|------|------|------|------|------|------|
| Line 1 | 2.8 | 7.7 | 10.4 | 6.7 | 3.3 | 0.9 | 14.4 | 4.0 | 9.8 | 0.9 | 6.3 |
| Line 1 | 5.3 | 4.9 | 11.8 | 6.9 | 0.8 | 12.1 | 9.5 | 3.2 | 20.0 | 0.1 | 8.8 |
| Line 1 | 9.7 | 5.9 | 10.2 | 10.0 | 1.7 | 8.1 | 20.7 | 0.4 | 20.1 | 6.3 | 6.3 |
| Line 2 | 1.1 | 14.7 | 4.9 | 10.1 | 2.7 | 0.7 | 5.9 | 0.8 | 1.1 | 0.8 | 11.0 |
| Line 2 | 6.3 | 3.7 | 0.4 | 9.4 | 5.1 | 8.9 | 1.9 | 13.5 | 0.2 | 19.4 | 12.8 |
| Line 2 | 6.0 | 5.1 | 6.1 | 7.7 | 1.0 | 6.3 | 10.9 | 5.6 | 8.9 | 2.5 | 9.1 |
| Line 3 | 1.4 | 15.4 | 5.4 | 8.6 | 1.5 | 1.4 | 0.3 | 1.9 | 4.0 | 7.4 | 11.2 |
| Line 3 | 1.7 | 3.4 | 2.6 | 14.3 | 1.1 | 3.2 | 1.7 | 2.0 | 9.0 | 2.7 | 18.8 |
| Line 3 | 9.0 | 7.5 | 3.4 | 10.8 | 3.9 | 1.6 | 13.3 | 0.9 | 15.8 | 4.7 | 4.0 |
| Line 4 | 1.9 | 11.5 | 3.9 | 1.3 | 2.0 | 5.2 | 12.3 | 4.1 | 7.2 | 14.5 | 15.0 |
| Line 4 | 0.2 | 5.1 | 9.1 | 5.9 | 6.4 | 0.9 | 3.9 | 0.6 | 0.6 | 14.1 | 16.1 |
| Line 4 | 2.1 | 0.4 | 5.3 | 4.3 | 6.8 | 1.3 | 5.8 | 0.4 | 0.7 | 11.7 | 11.2 |

Layout H-line (continued)

| | 12 | 13 | 14 | 15 | 16 | 17 | 18 | 19 | 20 | 21 | 22 |
|--------|------|------|------|------|------|------|------|------|------|------|------|
| Line 1 | 1.0 | 0.5 | 15.2 | 7.6 | 2.9 | 0.0 | 1.3 | 7.5 | 6.0 | 11.1 | 9.3 |
| Line 1 | 4.0 | 2.3 | 17.1 | 2.0 | 11.5 | 2.0 | 0.9 | 4.1 | 10.5 | 8.4 | 2.1 |
| Line 1 | 2.3 | 2.3 | 19.6 | 8.3 | 11.2 | 5.3 | 3.9 | 4.8 | 0.8 | 21.3 | 1.7 |
| Line 2 | 24.1 | 7.7 | 9.3 | 19.0 | 19.9 | 9.7 | 7.8 | 2.2 | 6.5 | 16.2 | 5.4 |
| Line 2 | 20.0 | 0.7 | 7.9 | 14.5 | 27.3 | 15.3 | 4.9 | 9.4 | 4.4 | 30.3 | 3.3 |
| Line 2 | 6.5 | 1.6 | 15.2 | 11.4 | 13.3 | 14.4 | 1.6 | 0.2 | 3.8 | 30.2 | 14.2 |
| Line 3 | 21.0 | 3.2 | 10.1 | 24.6 | 16.9 | 12.4 | 0.8 | 0.4 | 10.2 | 11.2 | 4.3 |
| Line 3 | 21.7 | 1.6 | 3.2 | 10.3 | 18.6 | 22.8 | 12.9 | 3.7 | 10.1 | 35.6 | 8.1 |
| Line 3 | 19.4 | 11.1 | 12.1 | 17.0 | 5.5 | 12.1 | 2.8 | 3.9 | 16.2 | 13.4 | 9.7 |
| Line 4 | 17.7 | 6.7 | 5.9 | 0.4 | 9.4 | 10.4 | 9.4 | 2.2 | 6.6 | 7.6 | 2.1 |
| Line 4 | 21.3 | 8.5 | 1.5 | 7.2 | 15.1 | 20.3 | 18.3 | 0.7 | 9.9 | 22.7 | 2.2 |
| Line 4 | 23.0 | 13.2 | 6.2 | 0.3 | 11.9 | 22.3 | 14.4 | 10.2 | 13.0 | 29.7 | 5.1 |

Layout D-line* (value of error shown in degree)

| | 1 | 2 | 3 | 4 | 5 | 6 | 7 | 8 | 9 | 10 | 11 |
|--------|----|----|----|----|----|----|----|----|----|----|----|
| Line 1 | 10 | 18 | 8 | 0 | 13 | 5 | 10 | 6 | 4 | 15 | 12 |
| Line 1 | 20 | 16 | 21 | 5 | 18 | 10 | 4 | 21 | 5 | 10 | 11 |
| Line 1 | 20 | 23 | 24 | 2 | 23 | 11 | 4 | 22 | 5 | 17 | 3 |
| Line 2 | 7 | 12 | 0 | 2 | 20 | 3 | 1 | 10 | 8 | 15 | 5 |
| Line 2 | 15 | 18 | 12 | 3 | 15 | 3 | 5 | 8 | 7 | 5 | 0 |
| Line 2 | 15 | 11 | 13 | 7 | 5 | 5 | 7 | 7 | 6 | 10 | 0 |
| Line 3 | 2 | 10 | 6 | 0 | 10 | 2 | 4 | 2 | 2 | 4 | 2 |
| Line 3 | 2 | 10 | 3 | 9 | 12 | 0 | 8 | 10 | 6 | 12 | 27 |
| Line 3 | 2 | 8 | 1 | 10 | 20 | 12 | 8 | 6 | 10 | 10 | 4 |

Layout D-line (continued)

| | 12 | 13 | 14 | 15 | 16 | 17 | 18 | 19 | 20 | 21 | 22 |
|--------|----|----|----|----|----|----|----|----|----|----|----|
| Line 1 | 9 | 15 | 11 | 25 | 5 | 14 | 4 | 10 | 15 | 10 | 15 |
| Line 1 | 11 | 23 | 13 | 30 | 6 | 15 | 2 | 24 | 26 | 17 | 14 |
| Line 1 | 17 | 16 | 0 | 30 | 4 | 0 | 1 | 6 | 30 | 18 | 12 |
| Line 2 | 20 | 10 | 3 | 0 | 10 | 5 | 0 | 5 | 1 | 7 | 0 |
| Line 2 | 5 | 5 | 9 | 11 | 5 | 0 | 15 | 10 | 20 | 7 | 0 |
| Line 2 | 14 | 8 | 8 | 15 | 0 | 8 | 3 | 1 | 8 | 10 | 0 |
| Line 3 | 15 | 2 | 6 | 12 | 23 | 10 | 13 | 5 | 10 | 10 | 0 |
| Line 3 | 16 | 5 | 13 | 15 | 10 | 7 | 8 | 12 | 10 | 14 | 8 |
| Line 3 | 10 | 10 | 12 | 10 | 8 | 20 | 14 | 0 | 10 | 7 | 14 |

Layout C-line

| | 1 | 2 | 3 | 4 | 5 | 6 | 7 | 8 | 9 | 10 | 11 |
|--------|------|-----|------|------|------|------|------|------|------|------|-----|
| Line 1 | 15.3 | 8.7 | 3.9 | 6.6 | 5.2 | 8.1 | 11.3 | 6.0 | 13.5 | 3.0 | 2.9 |
| Line 1 | 14.2 | 5.5 | 1.4 | 1.3 | 11.2 | 5.3 | 12.7 | 1.8 | 25.4 | 8.5 | 2.4 |
| Line 1 | 21.5 | 1.8 | 0.0 | 15.7 | 21.7 | 13.8 | 9.2 | 6.9 | 16.3 | 7.2 | 0.1 |
| Line 2 | 14.1 | 5.8 | 0.5 | 1.1 | 12.6 | 6.4 | 14.7 | 1.4 | 7.8 | 1.0 | 5.4 |
| Line 2 | 18.1 | 1.4 | 6.8 | 2.1 | 26.1 | 9.0 | 14.2 | 11.7 | 14.6 | 12.8 | 2.9 |
| Line 2 | 19.5 | 5.7 | 10.1 | 7.6 | 23.3 | 9.4 | 13.9 | 9.9 | 9.4 | 2.8 | 0.2 |
| Line 3 | 13.4 | 6.3 | 6.7 | 3.8 | 15.4 | 11.0 | 20.5 | 1.8 | 2.4 | 3.9 | 3.4 |
| Line 3 | 17.4 | 1.5 | 7.0 | 3.4 | 16.1 | 2.6 | 19.3 | 3.0 | 2.0 | 3.5 | 6.0 |
| Line 3 | 22.0 | 0.2 | 5.9 | 0.7 | 17.8 | 24.3 | 21.3 | 10.2 | 14.4 | 6.4 | 5.7 |

Layout C-line (continued)

| | 12 | 13 | 14 | 15 | 16 | 17 | 18 | 19 | 20 | 21 | 22 |
|--------|------|------|------|------|------|------|------|------|------|------|------|
| Line 1 | 7.1 | 19.9 | 13.7 | 0.9 | 8.8 | 6.4 | 18.6 | 2.1 | 7.1 | 28.0 | 1.5 |
| Line 1 | 10.4 | 15.4 | 26.3 | 11.9 | 11.2 | 5.8 | 10.8 | 3.2 | 4.6 | 8.0 | 4.7 |
| Line 1 | 15.0 | 8.6 | 36.7 | 7.4 | 11.5 | 23.4 | 9.7 | 3.5 | 4.6 | 0.6 | 8.5 |
| Line 2 | 9.1 | 18.3 | 21.8 | 7.1 | 11.3 | 6.3 | 5.1 | 0.3 | 3.5 | 12.9 | 9.9 |
| Line 2 | 9.3 | 4.4 | 25.1 | 6.9 | 8.1 | 11.3 | 2.6 | 7.5 | 12.6 | 9.1 | 16.8 |
| Line 2 | 13.1 | 4.8 | 30.0 | 5.3 | 9.4 | 3.5 | 17.7 | 15.6 | 22.0 | 1.4 | 16.4 |
| Line 3 | 18.2 | 2.6 | 11.9 | 8.7 | 2.0 | 1.4 | 10.0 | 3.6 | 2.9 | 22.9 | 2.3 |
| Line 3 | 14.3 | 19.6 | 20.5 | 8.5 | 3.4 | 3.7 | 5.1 | 7.3 | 17.0 | 18.7 | 4.5 |
| Line 3 | 20.0 | 2.8 | 31.6 | 15.5 | 1.3 | 14.9 | 18.0 | 21.0 | 25.1 | 3.1 | 31.6 |

Appendix 8 Specification of application prototypes

U-shape layout

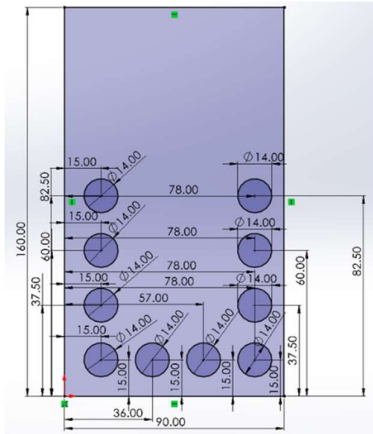

Diagonal alignment

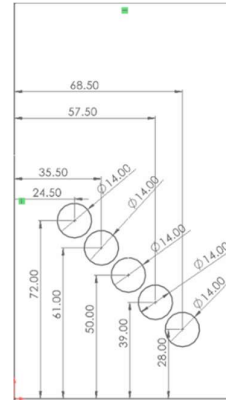

New format
(reversed L-shape)

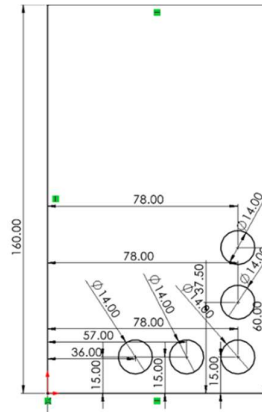

Conventional format
(plus-shape)

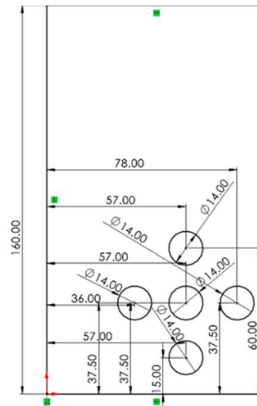

Conventional formats

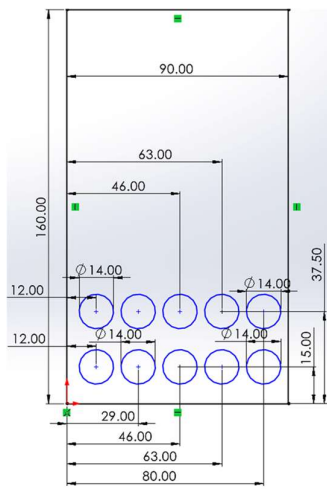

5x2

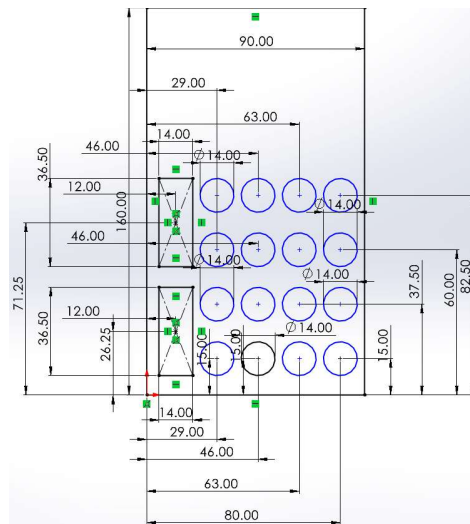

5x4

Appendix 9 Questionnaire on interface configuration formats

How mentally demanding is the menu selection under this eyes-free layout? (learning and *
memory)



Very low 1 2 3 4 5 6 7 Very high

How physically demanding is this layout under eyes-free menu selection? (thumb and hand *
control)

Very low 1 2 3 4 5 6 7 Very high

How mentally demanding is the menu selection under this eyes-free layout? (learning and memory) *



Very low 1 2 3 4 5 6 7 Very high

How physically demanding is this layout under eyes-free interaction? (thumb and hand control) *

Very low 1 2 3 4 5 6 7 Very high

How mentally demanding is the directional control menu under this eyes-free layout? *
(learning and memory) (Conventional format)



| | | | | | | | | |
|----------|-----------------------|-----------------------|-----------------------|-----------------------|-----------------------|-----------------------|-----------------------|-----------|
| | 1 | 2 | 3 | 4 | 5 | 6 | 7 | |
| Very low | <input type="radio"/> | <input type="radio"/> | <input type="radio"/> | <input type="radio"/> | <input type="radio"/> | <input type="radio"/> | <input type="radio"/> | Very high |

How physically demanding is this layout? (thumb and hand control) *

| | | | | | | | | |
|----------|-----------------------|-----------------------|-----------------------|-----------------------|-----------------------|-----------------------|-----------------------|-----------|
| | 1 | 2 | 3 | 4 | 5 | 6 | 7 | |
| Very low | <input type="radio"/> | <input type="radio"/> | <input type="radio"/> | <input type="radio"/> | <input type="radio"/> | <input type="radio"/> | <input type="radio"/> | Very high |

How mentally demanding is the directional control menu under this eyes-free layout?
(learning and memory) (new format) *

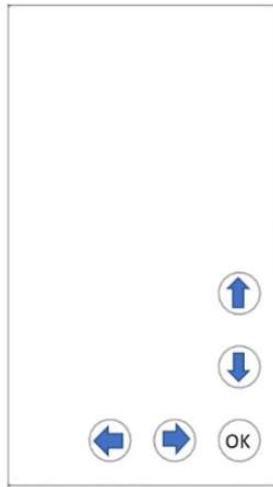

| | | | | | | | | |
|----------|-----------------------|-----------------------|-----------------------|-----------------------|-----------------------|-----------------------|-----------------------|-----------|
| | 1 | 2 | 3 | 4 | 5 | 6 | 7 | |
| Very low | <input type="radio"/> | <input type="radio"/> | <input type="radio"/> | <input type="radio"/> | <input type="radio"/> | <input type="radio"/> | <input type="radio"/> | Very high |

How physically demanding is this layout? (thumb and hand control) *

| | | | | | | | | |
|----------|-----------------------|-----------------------|-----------------------|-----------------------|-----------------------|-----------------------|-----------------------|-----------|
| | 1 | 2 | 3 | 4 | 5 | 6 | 7 | |
| Very low | <input type="radio"/> | <input type="radio"/> | <input type="radio"/> | <input type="radio"/> | <input type="radio"/> | <input type="radio"/> | <input type="radio"/> | Very high |

How mentally demanding is the calculator menu under this eyes-free layout? (learning and memory)*

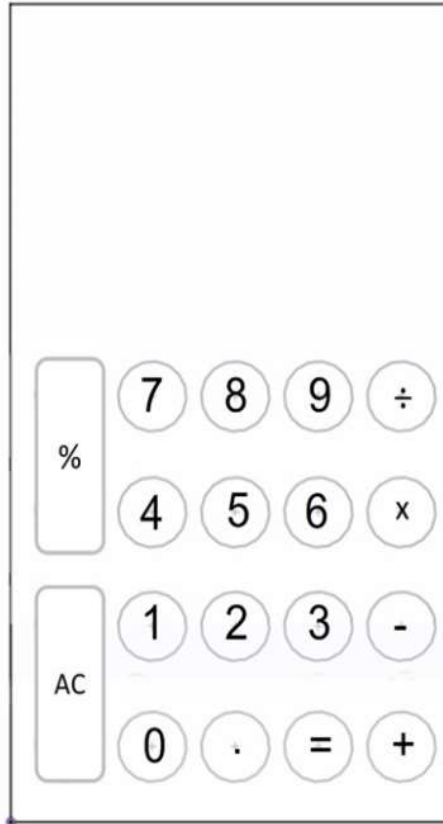

1 2 3 4 5 6 7

Very low Very high

How physically demanding is this layout under eyes-free menu selection? (thumb and hand control)*

1 2 3 4 5 6 7

Very low Very high

How mentally demanding is the calculator menu under this eyes-free layout? (learning and memory) *



Very low 1 2 3 4 5 6 7 Very high

How physically demanding is this layout under eyes-free menu selection? (thumb and hand control) *

Very low 1 2 3 4 5 6 7 Very high

Appendix 10 Data on the touch coordinates from the usability test

Discrete tasks

The U-shaped layout: Default menu

| Target | x ₁ | y ₁ | x ₂ | y ₂ | x ₃ | y ₃ | x ₄ | y ₄ | x ₅ | y ₅ |
|---------|-----------------|-----------------|-----------------|-----------------|-----------------|-----------------|-----------------|-----------------|-----------------|-----------------|
| | 15 | 15 | 36.0 | 15.0 | 57.0 | 15.0 | 78.0 | 15.0 | 15 | 82.5 |
| Results | x _{t1} | y _{t1} | x _{t2} | y _{t2} | x _{t3} | y _{t3} | x _{t4} | y _{t4} | x _{t5} | y _{t5} |
| 1 | 15.3 | 14.7 | 37.5 | 14.1 | 57.8 | 13.1 | 82.3 | 10.8 | 10.8 | 93.9 |
| 2 | 14.8 | 15.0 | 34.9 | 13.6 | 60.2 | 14.1 | 74.3 | 17.3 | 8.7 | 86.0 |
| 3 | 15.1 | 16.0 | 31.8 | 19.0 | 56.8 | 17.2 | 75.5 | 15.6 | 10.7 | 74.5 |
| 4 | 21.4 | 13.7 | 31.7 | 14.4 | 54.0 | 21.8 | 78.5 | 15.1 | 12.7 | 74.4 |
| 5 | 19.5 | 10.2 | 49.5 | 30.5 | 65.5 | 18.9 | 85.3 | 20.3 | 12.3 | 72.0 |
| 6 | 17.1 | 15.7 | 35.0 | 12.5 | 57.8 | 12.7 | 80.4 | 16.5 | 7.5 | 62.8 |
| 7 | 11.3 | 19.5 | 33.9 | 21.8 | 53.0 | 7.7 | 78.7 | 16.8 | 7.6 | 76.1 |
| 8 | 14.4 | 32.2 | 30.7 | 26.7 | 66.4 | 16.8 | 78.5 | 27.1 | 23.8 | 89.3 |
| 9 | 14.0 | 10.7 | 33.9 | 15.7 | 71.2 | 8.1 | 83.2 | 13.3 | 12.7 | 65.1 |
| 10 | 23.7 | 10.9 | 32.0 | 14.0 | 59.8 | 16.5 | 85.7 | 24.7 | 15.2 | 63.0 |
| 11 | 9.1 | 5.7 | 37.4 | 22.0 | 34.8 | 15.7 | 83.3 | 11.8 | 4.3 | 91.3 |

The U-shaped layout: Default menu (continued)

| Target | x ₆ | y ₆ | x ₇ | y ₇ | x ₈ | y ₈ | x ₉ | y ₉ | x ₁₀ | y ₁₀ |
|---------|-----------------|-----------------|-----------------|-----------------|-----------------|-----------------|-----------------|-----------------|------------------|------------------|
| | 15.0 | 60.0 | 15.0 | 37.5 | 78 | 82.5 | 78.0 | 60.0 | 78.0 | 37.5 |
| Results | x _{t6} | y _{t6} | x _{t7} | y _{t7} | x _{t8} | y _{t8} | x _{t9} | y _{t9} | x _{t10} | y _{t10} |
| 1 | 11.3 | 78.5 | 14.0 | 39.1 | 84.0 | 97.7 | 84.3 | 77.4 | 81.3 | 39.9 |
| 2 | 11.3 | 70.3 | 16.4 | 58.7 | 74.8 | 86.0 | 78.5 | 62.2 | 82.0 | 60.6 |
| 3 | 14.9 | 66.1 | 13.7 | 52.7 | 75.1 | 77.5 | 75.3 | 64.9 | 75.1 | 36.2 |
| 4 | 13.9 | 59.4 | 19.0 | 47.8 | 74.2 | 67.0 | 74.2 | 55.9 | 77.5 | 41.0 |
| 5 | 18.8 | 63.3 | 28.0 | 55.1 | 85.0 | 79.0 | 80.4 | 58.3 | 84.3 | 25.1 |
| 6 | 8.7 | 50.5 | 21.5 | 32.7 | 83.7 | 67.6 | 83.5 | 61.0 | 77.8 | 33.8 |
| 7 | 14.1 | 66.7 | 13.9 | 47.8 | 81.5 | 88.9 | 77.0 | 60.1 | 77.4 | 43.6 |
| 8 | 24.2 | 71.7 | 17.0 | 58.2 | 81.1 | 90.0 | 76.3 | 69.6 | 82.8 | 44.5 |
| 9 | 11.1 | 41.3 | 10.3 | 47.4 | 80.8 | 64.3 | 77.8 | 51.6 | 83.7 | 23.6 |
| 10 | 19.3 | 43.6 | 9.6 | 45.2 | 83.3 | 60.1 | 80.4 | 47.8 | 80.7 | 28.5 |
| 11 | 12.7 | 78.0 | 10.1 | 42.2 | 82.8 | 92.6 | 79.4 | 70.6 | 80.4 | 61.0 |

The U-shaped layout: Custom menu

| Target | x ₁ | y ₁ | x ₂ | y ₂ | x ₃ | y ₃ | x ₄ | y ₄ | x ₅ | y ₅ |
|---------|-----------------|-----------------|-----------------|-----------------|-----------------|-----------------|-----------------|-----------------|-----------------|-----------------|
| | 15 | 15 | 36.0 | 15.0 | 57.0 | 15.0 | 78.0 | 15.0 | 15 | 82.5 |
| Results | x _{t1} | y _{t1} | x _{t2} | y _{t2} | x _{t3} | y _{t3} | x _{t4} | y _{t4} | x _{t5} | y _{t5} |
| 1 | 12.5 | 12.6 | 27.3 | 12.6 | 54.0 | 11.1 | 78.0 | 12.7 | 13.8 | 75.1 |
| 2 | 16.9 | 11.8 | 30.2 | 11.8 | 50.4 | 19.9 | 75.0 | 16.4 | 16.6 | 79.8 |
| 3 | 16.8 | 17.0 | 31.3 | 17.0 | 52.1 | 18.2 | 76.1 | 16.4 | 10.3 | 70.1 |
| 4 | 25.4 | 17.4 | 34.6 | 17.9 | 60.0 | 23.0 | 80.4 | 8.6 | 32.4 | 68.9 |
| 5 | 22.3 | 15.7 | 47.0 | 14.0 | 65.3 | 18.4 | 84.0 | 6.3 | 20.9 | 78.6 |
| 6 | 12.0 | 6.3 | 42.6 | 16.5 | 57.2 | 4.2 | 80.7 | 8.9 | 12.2 | 91.9 |
| 7 | 10.7 | 20.2 | 28.9 | 19.1 | 53.7 | 23.5 | 75.9 | 16.6 | 8.0 | 83.7 |
| 8 | 20.2 | 16.9 | 31.9 | 11.1 | 66.5 | 14.1 | 73.2 | 1.2 | 28.3 | 86.5 |
| 9 | 10.7 | 10.5 | 31.7 | 13.9 | 59.0 | 6.8 | 76.0 | 10.5 | 7.9 | 69.7 |
| 10 | 21.1 | 10.2 | 33.9 | 8.2 | 51.3 | 6.2 | 86.1 | 3.6 | 15.9 | 56.1 |
| 11 | 8.2 | 7.0 | 33.1 | 12.7 | 54.2 | 10.6 | 82.3 | 16.5 | 6.7 | 91.0 |

The U-shaped layout: Custom menu (continued)

| Target | x ₆ | y ₆ | x ₇ | y ₇ | x ₈ | y ₈ | x ₉ | y ₉ | x ₁₀ | y ₁₀ |
|---------|-----------------|-----------------|-----------------|-----------------|-----------------|-----------------|-----------------|-----------------|------------------|------------------|
| | 15.0 | 60.0 | 15.0 | 37.5 | 78 | 82.5 | 78.0 | 60.0 | 78.0 | 37.5 |
| Results | x _{t6} | y _{t6} | x _{t7} | y _{t7} | x _{t8} | y _{t8} | x _{t9} | y _{t9} | x _{t10} | y _{t10} |
| 1 | 7.5 | 63.5 | 12.0 | 42.4 | 80.0 | 88.0 | 74.0 | 63.8 | 76.0 | 33.4 |
| 2 | 10.5 | 57.6 | 7.0 | 40.7 | 79.9 | 80.7 | 77.8 | 52.9 | 79.7 | 42.1 |
| 3 | 9.5 | 56.7 | 13.2 | 34.6 | 78.4 | 80.5 | 77.6 | 59.9 | 79.9 | 42.9 |
| 4 | 10.3 | 45.0 | 22.3 | 35.7 | 74.9 | 53.6 | 73.9 | 35.9 | 78.2 | 42.4 |
| 5 | 19.5 | 59.9 | 31.3 | 32.9 | 80.8 | 65.7 | 81.0 | 48.8 | 78.8 | 25.1 |
| 6 | 11.4 | 58.1 | 12.6 | 24.0 | 81.1 | 78.1 | 79.3 | 60.8 | 82.8 | 35.4 |
| 7 | 6.1 | 58.0 | 15.2 | 54.4 | 80.4 | 80.8 | 82.4 | 65.0 | 80.7 | 57.8 |
| 8 | 23.8 | 71.4 | 26.5 | 41.0 | 85.4 | 96.0 | 81.8 | 72.8 | 79.9 | 41.0 |
| 9 | 9.0 | 33.9 | 8.3 | 35.0 | 81.5 | 60.8 | 84.3 | 62.3 | 83.4 | 29.3 |
| 10 | 19.5 | 40.7 | 20.4 | 26.5 | 84.3 | 61.2 | 85.0 | 37.2 | 84.6 | 31.8 |
| 11 | 3.1 | 67.1 | 5.4 | 46.1 | 79.7 | 106.7 | 80.6 | 74.8 | 77.5 | 71.4 |

The underlined N-shaped layout: Calculator menu

| Target | x ₁ | y ₁ | x ₂ | y ₂ | x ₃ | y ₃ | x ₄ | y ₄ | x ₅ | y ₅ |
|---------|-----------------|-----------------|-----------------|-----------------|-----------------|-----------------|-----------------|-----------------|-----------------|-----------------|
| | 15 | 15 | 36.0 | 15.0 | 57.0 | 15.0 | 78.0 | 15.0 | 15 | 82.5 |
| Results | x _{t1} | y _{t1} | x _{t2} | y _{t2} | x _{t3} | y _{t3} | x _{t4} | y _{t4} | x _{t5} | y _{t5} |
| 1 | 19.9 | 5.3 | 38.4 | 2.9 | 47.3 | 10.1 | 75.4 | 4.8 | 13.4 | 84.9 |
| 2 | 19.8 | 13.6 | 36.3 | 15.1 | 58.5 | 22.0 | 76.1 | 15.6 | 16.5 | 61.2 |
| 3 | 13.1 | 12.9 | 23.8 | 17.5 | 63.8 | 18.1 | 77.3 | 14.0 | 9.4 | 72.9 |
| 4 | 25.4 | 28.4 | 36.2 | 21.8 | 64.6 | 22.7 | 70.1 | 10.7 | 31.2 | 88.1 |
| 5 | 7.4 | 15.6 | 35.7 | 18.1 | 49.8 | 12.1 | 77.2 | 9.6 | 5.2 | 66.3 |
| 6 | 13.0 | 5.1 | 38.5 | 0.2 | 54.1 | 5.8 | 74.1 | 4.5 | 9.0 | 84.5 |
| 7 | 15.0 | 10.4 | 29.8 | 32.4 | 64.5 | 24.2 | 81.8 | 27.8 | 18.0 | 74.4 |
| 8 | 21.8 | 22.7 | 43.0 | 20.9 | 65.0 | 19.2 | 72.2 | 17.4 | 22.1 | 74.7 |
| 9 | 16.2 | 15.8 | 29.4 | 15.2 | 55.3 | 12.6 | 71.5 | 15.8 | 15.4 | 83.9 |
| 10 | 19.9 | 12.3 | 28.4 | 18.0 | 44.3 | 20.1 | 75.0 | 18.5 | 14.1 | 83.7 |
| 11 | 14.0 | 17.0 | 32.3 | 12.6 | 56.8 | 18.3 | 71.4 | 14.7 | 10.0 | 86.4 |

The underlined N-shaped layout: Calculator menu (continued)

| Target | x ₆ | y ₆ | x ₇ | y ₇ | x ₈ | y ₈ | x ₉ | y ₉ | x ₁₀ | y ₁₀ |
|---------|-----------------|-----------------|-----------------|-----------------|-----------------|-----------------|-----------------|-----------------|------------------|------------------|
| | 15.0 | 60.0 | 15.0 | 37.5 | 78 | 82.5 | 78.0 | 60.0 | 78.0 | 37.5 |
| Results | x _{t6} | y _{t6} | x _{t7} | y _{t7} | x _{t8} | y _{t8} | x _{t9} | y _{t9} | x _{t10} | y _{t10} |
| 1 | 8.9 | 66.3 | 2.4 | 36.6 | 87.6 | 95.8 | 76.8 | 74.6 | 85.2 | 41.1 |
| 2 | 21.7 | 49.4 | 22.2 | 28.0 | 82.6 | 74.3 | 78.9 | 44.1 | 82.0 | 35.8 |
| 3 | 19.2 | 47.4 | 15.1 | 38.0 | 83.7 | 78.7 | 84.5 | 52.5 | 83.9 | 36.7 |
| 4 | 20.9 | 63.3 | 18.0 | 49.4 | 87.1 | 91.4 | 82.1 | 64.7 | 70.3 | 25.0 |
| 5 | 10.4 | 73.4 | 3.9 | 44.3 | 79.8 | 71.9 | 73.7 | 64.0 | 79.3 | 40.9 |
| 6 | 10.1 | 67.8 | 13.4 | 25.9 | 77.5 | 94.5 | 82.8 | 45.4 | 80.9 | 32.7 |
| 7 | 11.8 | 58.5 | 14.0 | 43.0 | 86.3 | 77.1 | 85.3 | 57.3 | 83.1 | 38.8 |
| 8 | 36.0 | 64.9 | 35.0 | 40.8 | 78.2 | 82.6 | 75.1 | 50.1 | 71.0 | 40.6 |
| 9 | 13.5 | 52.3 | 14.3 | 42.9 | 72.3 | 55.5 | 79.3 | 64.3 | 78.0 | 40.3 |
| 10 | 14.3 | 35.1 | 21.1 | 37.2 | 68.9 | 84.9 | 76.9 | 76.3 | 78.3 | 41.2 |
| 11 | 10.8 | 67.9 | 9.8 | 37.3 | 80.8 | 92.3 | 76.3 | 59.7 | 81.0 | 36.7 |

The underlined N-shaped layout: Calculator menu (continued)

| Target | x ₁₁ | y ₁₁ | x ₁₂ | y ₁₂ | x ₁₃ | y ₁₃ | x ₁₄ | y ₁₄ | x ₁₅ | y ₁₅ |
|---------|------------------|------------------|------------------|------------------|------------------|------------------|------------------|------------------|------------------|------------------|
| | 24.5 | 72 | 35.5 | 61.0 | 46.5 | 50.0 | 57.5 | 39.0 | 68.5 | 28.0 |
| Results | x _{t11} | y _{t11} | x _{t12} | y _{t12} | x _{t13} | y _{t13} | x _{t14} | y _{t14} | x _{t15} | y _{t15} |
| 1 | 30.5 | 76.1 | 29.3 | 68.4 | 45.0 | 51.7 | 61.9 | 39.8 | 67.0 | 27.3 |
| 2 | 25.8 | 69.4 | 36.8 | 65.4 | 52.7 | 49.0 | 61.4 | 59.2 | 64.2 | 35.4 |
| 3 | 34.7 | 66.3 | 32.8 | 74.5 | 52.6 | 48.5 | 59.9 | 32.8 | 63.5 | 24.6 |
| 4 | 42.7 | 73.5 | 56.2 | 67.9 | 59.0 | 58.9 | 65.8 | 36.4 | 72.2 | 36.4 |
| 5 | 33.5 | 60.4 | 49.8 | 64.5 | 62.5 | 37.9 | 53.8 | 63.1 | 63.8 | 46.4 |
| 6 | 29.1 | 68.3 | 38.7 | 73.7 | 55.4 | 53.4 | 58.9 | 43.4 | 70.2 | 26.3 |
| 7 | 27.6 | 66.3 | 26.1 | 56.3 | 47.2 | 45.1 | 57.2 | 37.6 | 68.7 | 23.3 |
| 8 | 51.1 | 92.8 | 55.7 | 76.1 | 54.2 | 71.4 | 57.8 | 43.6 | 70.8 | 23.4 |
| 9 | 30.6 | 72.1 | 37.8 | 65.6 | 51.8 | 47.4 | 67.7 | 40.4 | 72.1 | 27.1 |
| 10 | 34.3 | 59.2 | 37.6 | 43.6 | 51.1 | 40.1 | 70.4 | 32.3 | 68.5 | 22.9 |
| 11 | 28.1 | 78.3 | 26.5 | 89.7 | 45.4 | 58.4 | 49.7 | 45.9 | 66.0 | 27.3 |

Serial tasks

The plus-shaped layout

| UP | | DOWN | | OK | | LEFT | | RIGHT | |
|-----------------|-----------------|-----------------|-----------------|-----------------|-----------------|-----------------|-----------------|-----------------|-----------------|
| x ₁ | y ₁ | x ₂ | y ₂ | x ₃ | y ₃ | x ₄ | y ₄ | x ₅ | y ₅ |
| 57 | 60 | 57 | 15 | 57.0 | 37.5 | 36.0 | 37.5 | 78.0 | 37.5 |
| x _{t1} | y _{t1} | x _{t2} | y _{t2} | x _{t3} | y _{t3} | x _{t4} | y _{t4} | x _{t5} | y _{t5} |
| 61.5 | 63.5 | 62.8 | 20.3 | 65.5 | 52.5 | 35.0 | 51.2 | 79.9 | 39.5 |
| 61.0 | 61.7 | 57.9 | 22.3 | 59.5 | 40.9 | 38.5 | 53.8 | 78.0 | 42.7 |
| 67.3 | 73.8 | 53.3 | 22.9 | 58.5 | 43.0 | 39.0 | 48.6 | 75.8 | 41.4 |
| 61.5 | 71.0 | 61.5 | 9.6 | 51.8 | 48.6 | 58.1 | 68.2 | 56.7 | 42.5 |
| 57.2 | 57.3 | 59.1 | 8.1 | 66.1 | 26.2 | 43.0 | 22.4 | 75.9 | 25.1 |
| 75.5 | 41.2 | 58.3 | 7.4 | 56.0 | 59.0 | 43.9 | 19.2 | 81.1 | 29.3 |
| 34.5 | 44.6 | 61.2 | 20.4 | 54.1 | 67.5 | 37.9 | 34.8 | 74.9 | 32.0 |
| 58.6 | 43.2 | 59.5 | 18.0 | 54.6 | 19.9 | 40.8 | 40.0 | 74.2 | 36.8 |
| 57.0 | 54.1 | 52.6 | 19.8 | 61.8 | 42.1 | 42.5 | 33.6 | 70.7 | 38.0 |
| 56.6 | 52.5 | 69.8 | 21.1 | 54.5 | 34.2 | 47.0 | 10.1 | 76.6 | 41.0 |
| 55.3 | 54.7 | 67.7 | 14.8 | 59.7 | 33.8 | 54.5 | 41.7 | 84.5 | 41.5 |
| 58.0 | 48.9 | 64.8 | 14.4 | 49.0 | 38.2 | 52.8 | 37.3 | 81.8 | 46.6 |
| 67.4 | 58.4 | 62.0 | 28.8 | 73.0 | 45.9 | 32.0 | 45.2 | 78.3 | 50.3 |
| 67.9 | 58.0 | 65.8 | 27.3 | 62.6 | 34.1 | 40.5 | 53.9 | 80.1 | 56.0 |
| 65.2 | 28.0 | 53.5 | 33.8 | 67.7 | 35.2 | 43.5 | 52.9 | 80.3 | 58.7 |
| 60.7 | 26.2 | 58.9 | 11.6 | 69.1 | 40.6 | 39.1 | 38.3 | 79.6 | 45.0 |
| 62.0 | 71.1 | 56.1 | 12.2 | 62.3 | 51.5 | 29.8 | 43.6 | 81.3 | 44.1 |
| 64.8 | 69.4 | 55.7 | 13.1 | 59.5 | 49.5 | 35.2 | 45.6 | 75.9 | 45.6 |
| 58.0 | 72.7 | 63.3 | 18.7 | 57.5 | 50.0 | 39.8 | 40.9 | 85.4 | 43.4 |
| 61.8 | 64.8 | 63.0 | 20.2 | 57.3 | 52.4 | 46.3 | 39.1 | 81.1 | 34.9 |
| 58.7 | 72.3 | 58.7 | 17.2 | 61.5 | 46.7 | 46.3 | 32.2 | 80.2 | 38.9 |
| 57.4 | 68.8 | 63.6 | 3.9 | 58.3 | 40.3 | 49.4 | 30.4 | 80.2 | 25.3 |

| UP | | DOWN | | OK | | LEFT | | RIGHT | |
|-----------------|-----------------|-----------------|-----------------|-----------------|-----------------|-----------------|-----------------|-----------------|-----------------|
| x ₁ | y ₁ | x ₂ | y ₂ | x ₃ | y ₃ | x ₄ | y ₄ | x ₅ | y ₅ |
| 57 | 60 | 57 | 15 | 57.0 | 37.5 | 36.0 | 37.5 | 78.0 | 37.5 |
| x _{t1} | y _{t1} | x _{t2} | y _{t2} | x _{t3} | y _{t3} | x _{t4} | y _{t4} | x _{t5} | y _{t5} |
| 67.2 | 71.0 | 62.2 | 7.2 | 61.3 | 42.9 | 49.7 | 29.4 | 80.6 | 34.3 |
| 63.0 | 64.5 | 52.1 | 5.6 | 55.4 | 45.6 | 65.8 | 43.4 | 77.0 | 34.6 |
| 69.6 | 64.0 | 58.5 | 12.5 | 62.8 | 41.1 | 41.3 | 38.3 | 83.4 | 43.3 |
| 70.2 | 49.5 | 48.7 | 11.1 | 62.0 | 38.2 | 41.3 | 33.7 | 79.3 | 46.1 |
| 63.3 | 60.7 | 60.9 | 10.9 | 65.0 | 44.1 | 85.2 | 45.5 | 80.2 | 39.8 |
| 64.1 | 59.0 | 50.4 | 22.7 | 53.7 | 34.5 | 31.3 | 44.3 | 74.6 | 40.5 |
| 66.5 | 45.0 | 47.2 | 21.8 | 62.6 | 29.2 | 29.1 | 43.6 | 80.9 | 45.0 |
| 71.0 | 43.6 | 50.2 | 11.8 | 62.9 | 19.7 | 32.4 | 38.3 | 76.5 | 46.5 |
| 46.8 | 17.4 | 46.8 | 27.6 | 65.8 | 23.9 | 8.9 | 58.6 | 70.8 | 48.6 |
| 66.7 | 42.7 | 45.8 | 23.9 | 58.8 | 30.1 | 13.4 | 50.4 | 77.5 | 57.3 |
| 56.6 | 52.2 | 48.24 | 20.96 | 62.7 | 32.8 | 23.3 | 50.4 | 75.6 | 62.1 |
| 55.9 | 50.3 | | | 56.1 | 32.3 | | | | |
| 53.1 | 8.5 | | | 56.8 | 38.7 | | | | |
| 56.1 | 8.7 | | | 50.7 | 37.8 | | | | |
| 57.4 | 65.2 | | | 58.5 | 46.1 | | | | |
| 56.5 | 63.9 | | | 53.3 | 33.4 | | | | |
| 61.7 | 66.8 | | | 56.7 | 40.1 | | | | |
| 55.0 | 62.3 | | | 55.2 | 40.1 | | | | |
| 49.7 | 75.1 | | | 46.8 | 58.6 | | | | |
| 50.9 | 71.4 | | | 45.4 | 46.7 | | | | |
| 54.2 | 80.7 | | | 49.7 | 45.9 | | | | |
| 51.8 | 74.6 | | | 50.6 | 54.1 | | | | |

The reversed L-shaped layout

| UP | | DOWN | | OK | | LEFT | | RIGHT | |
|-----------------|-----------------|-----------------|-----------------|-----------------|-----------------|-----------------|-----------------|-----------------|-----------------|
| x ₁ | y ₁ | x ₂ | y ₂ | x ₃ | y ₃ | x ₄ | y ₄ | x ₅ | y ₅ |
| 78 | 60 | 78 | 37.5 | 78 | 15 | 36 | 15 | 57 | 15 |
| x _{t1} | y _{t1} | x _{t2} | y _{t2} | x _{t3} | y _{t3} | x _{t4} | y _{t4} | x _{t5} | y _{t5} |
| 85.5 | 80.3 | 81.3 | 54.5 | 77.5 | 14.1 | 33.5 | 22.9 | 51.8 | 17.2 |
| 85.8 | 77.4 | 80.0 | 46.0 | 77.8 | 14.7 | 33.0 | 16.5 | 46.3 | 12.6 |
| 80.5 | 71.8 | 77.3 | 45.3 | 77.0 | 17.2 | 32.5 | 16.5 | 53.3 | 16.2 |
| 87.3 | 73.6 | 79.7 | 48.6 | 76.5 | 14.4 | 40.5 | 27.3 | 53.9 | 21.0 |
| 77.1 | 75.1 | 76.9 | 39.1 | 72.9 | 23.6 | 32.1 | 9.5 | 51.8 | 21.5 |
| 80.2 | 71.9 | 77.8 | 51.8 | 72.0 | 24.7 | 36.1 | 16.6 | 52.3 | 20.1 |
| 76.2 | 70.1 | 72.1 | 37.4 | 69.1 | 22.0 | 35.3 | 13.6 | 53.7 | 14.0 |
| 75.7 | 61.3 | 73.0 | 35.4 | 77.3 | 17.3 | 32.8 | 13.8 | 60.6 | 17.2 |
| 73.2 | 61.5 | 78.9 | 43.3 | 78.2 | 19.2 | 32.4 | 14.2 | 59.5 | 19.0 |
| 77.0 | 59.5 | 82.3 | 35.7 | 74.6 | 13.8 | 37.7 | 17.6 | 64.3 | 11.4 |
| 73.4 | 52.1 | 72.0 | 37.8 | 74.0 | 13.4 | 51.1 | 18.3 | 65.0 | 17.6 |
| 75.1 | 54.5 | 80.9 | 39.4 | 76.1 | 15.0 | 55.0 | 19.0 | 66.7 | 17.2 |
| 78.2 | 53.8 | 83.0 | 37.0 | 81.4 | 23.2 | 34.0 | 21.0 | 52.3 | 26.3 |

| UP | | DOWN | | OK | | LEFT | | RIGHT | |
|-----------------|-----------------|-----------------|-----------------|-----------------|-----------------|-----------------|-----------------|-----------------|-----------------|
| x ₁ | y ₁ | x ₂ | y ₂ | x ₃ | y ₃ | x ₄ | y ₄ | x ₅ | y ₅ |
| 78 | 60 | 78 | 37.5 | 78 | 15 | 36 | 15 | 57 | 15 |
| x _{t1} | y _{t1} | x _{t2} | y _{t2} | x _{t3} | y _{t3} | x _{t4} | y _{t4} | x _{t5} | y _{t5} |
| 80.6 | 53.6 | 78.3 | 38.2 | 78.0 | 15.8 | 41.0 | 16.7 | 57.5 | 16.4 |
| 80.4 | 58.4 | 81.3 | 36.5 | 79.2 | 13.7 | 38.5 | 19.8 | 55.5 | 17.9 |
| 76.8 | 55.0 | 82.6 | 58.3 | 78.5 | 17.4 | 55.2 | 12.7 | 60.9 | 14.5 |
| 76.5 | 55.3 | 81.3 | 57.2 | 83.0 | 22.0 | 55.0 | 11.1 | 58.9 | 6.5 |
| 75.8 | 49.8 | 83.3 | 55.9 | 82.0 | 21.8 | 57.4 | 15.4 | 57.2 | 14.0 |
| 81.5 | 68.4 | 81.3 | 46.1 | 80.8 | 16.7 | 30.0 | 11.6 | 54.8 | 7.7 |
| 80.0 | 59.7 | 81.7 | 49.9 | 80.8 | 21.5 | 27.8 | 13.7 | 55.7 | 11.6 |
| 83.0 | 74.1 | 80.2 | 44.9 | 82.0 | 13.8 | 22.6 | 18.1 | 57.4 | 9.6 |
| 83.0 | 71.0 | 85.7 | 35.9 | 79.3 | 18.7 | 37.7 | 6.7 | 62.4 | 8.1 |
| 84.5 | 72.0 | 82.3 | 24.8 | 81.3 | 12.0 | 32.9 | 6.3 | 61.7 | 2.8 |
| 87.0 | 67.9 | 83.3 | 33.4 | 82.4 | 20.3 | 35.3 | 6.3 | 67.0 | 9.3 |
| 79.1 | 62.8 | 84.8 | 24.3 | 78.0 | 11.8 | 36.9 | 11.1 | 65.5 | 7.9 |
| 77.6 | 61.1 | 84.1 | 24.7 | 80.2 | 5.8 | 39.1 | 11.6 | 66.2 | 8.5 |
| 77.0 | 61.3 | 82.8 | 34.1 | 79.8 | 11.2 | 67.3 | 9.0 | 64.7 | 7.0 |
| 79.1 | 63.0 | 76.1 | 23.1 | 83.3 | 11.8 | 40.4 | 13.6 | 58.0 | 7.8 |
| 79.4 | 42.9 | 73.5 | 26.9 | 82.8 | 11.1 | 40.9 | 12.5 | 61.5 | 13.6 |
| 81.4 | 43.1 | 80.0 | 35.2 | 79.7 | 5.1 | 40.7 | 11.6 | 63.7 | 10.0 |
| 81.4 | 48.2 | 80.2 | 65.0 | 78.7 | 8.1 | 25.9 | 15.7 | 57.4 | 8.5 |
| 79.7 | 53.8 | 76.6 | 65.0 | 75.6 | 5.3 | 20.9 | 18.3 | 58.8 | 5.0 |
| 84.3 | 57.7 | 81.8 | 59.2 | 84.5 | 12.9 | 22.8 | 14.9 | 55.7 | 13.3 |
| 84.3 | 54.4 | | | 82.1 | 14.9 | | | | |
| 84.3 | 26.9 | | | 80.4 | 10.1 | | | | |
| 84.3 | 28.0 | | | 81.9 | 9.6 | | | | |
| 78.7 | 49.2 | | | 80.9 | 15.1 | | | | |
| 78.7 | 50.3 | | | 78.3 | 14.9 | | | | |
| 76.7 | 43.2 | | | 75.9 | 13.1 | | | | |
| 74.6 | 29.4 | | | 79.3 | 13.8 | | | | |
| 72.2 | 67.1 | | | 74.6 | 16.7 | | | | |
| 75.4 | 66.3 | | | 76.6 | 16.5 | | | | |
| 76.1 | 95.3 | | | 74.2 | 16.7 | | | | |
| 76.8 | 83.8 | | | 82.6 | 18.8 | | | | |

The underlined N-shaped layout: Calculator application

| 1 | | 2 | | 3 | | 4 | | 5 | |
|-----------------|-----------------|-----------------|-----------------|-----------------|-----------------|-----------------|-----------------|-----------------|-----------------|
| x ₁ | y ₁ | x ₂ | y ₂ | x ₃ | y ₃ | x ₄ | y ₄ | x ₅ | y ₅ |
| 15 | 15 | 36 | 15 | 57 | 15 | 78 | 15 | 15 | 82.5 |
| x _{t1} | y _{t1} | x _{t2} | y _{t2} | x _{t3} | y _{t3} | x _{t4} | y _{t4} | x _{t5} | y _{t5} |
| 11.3 | 9.2 | 40.1 | 15.7 | 59.8 | 16.7 | 74.2 | 16.5 | 17.0 | 101.1 |
| 16.6 | 3.4 | 26.6 | 18.6 | 60.0 | 8.0 | 77.6 | 18.5 | 14.2 | 92.1 |
| 18.5 | 23.1 | 40.2 | 20.9 | 58.7 | 21.4 | 80.4 | 10.5 | 15.6 | 96.8 |

| 1 | | 2 | | 3 | | 4 | | 5 | |
|-----------------|-----------------|-----------------|-----------------|-----------------|-----------------|-----------------|-----------------|-----------------|-----------------|
| x ₁ | y ₁ | x ₂ | y ₂ | x ₃ | y ₃ | x ₄ | y ₄ | x ₅ | y ₅ |
| 15 | 15 | 36 | 15 | 57 | 15 | 78 | 15 | 15 | 82.5 |
| x _{t1} | y _{t1} | x _{t2} | y _{t2} | x _{t3} | y _{t3} | x _{t4} | y _{t4} | x _{t5} | y _{t5} |
| 20.7 | 20.5 | 36.5 | 23.6 | 49.1 | 22.3 | 75.8 | 0.5 | 15.7 | 79.2 |
| 11.6 | 17.5 | 43.3 | 14.0 | 66.2 | 14.0 | 76.5 | 22.9 | 19.8 | 69.0 |
| 12.9 | 13.6 | 36.0 | 14.0 | 63.8 | 19.9 | 84.1 | 7.6 | 19.1 | 70.1 |
| 29.8 | 18.8 | 52.1 | 3.0 | 71.3 | 1.9 | 81.4 | 18.9 | 14.2 | 70.8 |
| 31.7 | 10.7 | 44.4 | 8.8 | 67.4 | 13.7 | 75.6 | 24.6 | 10.0 | 72.1 |
| 21.3 | 15.0 | 48.9 | 17.7 | 67.8 | 18.1 | 75.3 | 12.6 | 12.0 | 57.5 |
| 20.2 | 22.0 | 41.5 | 15.0 | 60.2 | 17.0 | 73.1 | 23.4 | 34.1 | 70.5 |
| 17.2 | 13.1 | 40.2 | 5.1 | 63.0 | 6.9 | 74.3 | 18.8 | 16.8 | 53.3 |
| 16.1 | 15.6 | 45.2 | 7.1 | 59.3 | 12.0 | | | 23.8 | 52.2 |
| 18.3 | 24.7 | 41.0 | 16.4 | 53.8 | 16.7 | | | 14.1 | 60.3 |
| 24.3 | 15.7 | 43.5 | 24.2 | 61.3 | 23.9 | | | 12.6 | 87.5 |
| 32.9 | 23.2 | 54.7 | 26.0 | 72.2 | 22.7 | | | 9.1 | 81.0 |
| 28.8 | 24.1 | 57.1 | 26.7 | 67.7 | 23.9 | | | 10.0 | 91.0 |
| 12.4 | 17.2 | 37.6 | 14.8 | 58.9 | 12.4 | | | 8.9 | 78.5 |
| 14.9 | 11.4 | 35.5 | 16.8 | 60.6 | 13.2 | | | 8.9 | 82.1 |
| 12.9 | 23.1 | 31.6 | 26.8 | 53.9 | 27.7 | | | 23.3 | 71.5 |
| 13.4 | 22.0 | 30.5 | 28.9 | 56.3 | 29.1 | | | 30.0 | 69.8 |
| 15.8 | 18.3 | 38.8 | 20.3 | 63.0 | 20.3 | | | 28.8 | 67.1 |
| 16.5 | 19.0 | 30.5 | 16.7 | 51.5 | 20.6 | | | 42.0 | 69.6 |
| ... | | | | | | | | | |

The underlined N-shaped layout: Calculator application (continued)

| 6 | | 7 | | 8 | | 9 | | 0 | |
|-----------------|-----------------|-----------------|-----------------|-----------------|-----------------|-----------------|-----------------|------------------|------------------|
| x ₆ | y ₆ | x ₇ | y ₇ | x ₈ | y ₈ | x ₉ | y ₉ | x ₁₀ | y ₁₀ |
| 15 | 60 | 15 | 37.5 | 78 | 82.5 | 78 | 60 | 78 | 37.5 |
| x _{t6} | y _{t6} | x _{t7} | y _{t7} | x _{t8} | y _{t8} | x _{t9} | y _{t9} | x _{t10} | y _{t10} |
| 15.4 | 65.8 | 23.0 | 41.7 | 81.4 | 103.2 | 82.8 | 68.7 | 76.6 | 61.6 |
| 14.2 | 66.6 | 13.0 | 48.8 | 75.9 | 64.3 | 80.6 | 72.7 | 77.6 | 51.8 |
| 17.8 | 75.9 | 18.9 | 39.4 | 85.8 | 82.6 | 76.7 | 51.6 | 80.8 | 34.3 |
| 18.3 | 59.9 | 17.6 | 40.3 | 87.6 | 80.7 | 77.0 | 52.1 | 81.6 | 29.0 |
| 19.3 | 60.8 | 12.7 | 35.8 | 82.6 | 80.6 | 81.9 | 54.4 | 81.7 | 37.4 |
| 20.9 | 47.4 | 14.0 | 27.5 | 86.3 | 75.2 | 81.7 | 54.9 | 75.9 | 36.3 |
| 13.1 | 35.8 | 27.6 | 38.0 | 82.1 | 68.8 | 83.3 | 45.2 | 85.3 | 41.8 |
| 12.5 | 50.5 | 21.4 | 20.2 | 79.0 | 87.2 | 79.3 | 31.8 | 72.0 | 37.6 |
| 12.7 | 47.0 | 17.4 | 31.4 | 77.0 | 66.9 | 79.8 | 60.9 | 78.7 | 39.5 |
| 24.7 | 30.8 | 15.7 | 37.6 | 78.0 | 89.2 | 82.6 | 53.2 | 79.5 | 44.9 |
| 29.0 | 54.5 | 11.5 | 14.0 | 79.5 | 87.2 | 88.0 | 59.6 | 75.5 | 38.6 |
| 25.4 | 32.2 | 10.8 | 25.7 | | | 87.0 | 61.9 | | |
| 16.3 | 60.3 | 29.8 | 33.6 | | | 80.3 | 45.4 | | |
| 15.2 | 48.4 | 26.3 | 42.8 | | | 81.0 | 51.0 | | |

| 6 | | 7 | | 8 | | 9 | | 0 | |
|-----------------|-----------------|-----------------|-----------------|-----------------|-----------------|-----------------|-----------------|------------------|------------------|
| x ₆ | y ₆ | x ₇ | y ₇ | x ₈ | y ₈ | x ₉ | y ₉ | x ₁₀ | y ₁₀ |
| 15 | 60 | 15 | 37.5 | 78 | 82.5 | 78 | 60 | 78 | 37.5 |
| x _{t6} | y _{t6} | x _{t7} | y _{t7} | x _{t8} | y _{t8} | x _{t9} | y _{t9} | x _{t10} | y _{t10} |
| 19.8 | 41.6 | 44.2 | 45.2 | | | 82.1 | 58.4 | | |
| 11.2 | 57.6 | 37.0 | 40.1 | | | 77.3 | 59.4 | | |
| 13.0 | 48.1 | 14.1 | 34.4 | | | 76.1 | 51.7 | | |
| 9.0 | 45.1 | 12.2 | 25.2 | | | 75.5 | 50.7 | | |
| 29.8 | 58.5 | 17.1 | 43.0 | | | 77.3 | 75.6 | | |
| 22.8 | 44.2 | 15.9 | 45.1 | | | 79.7 | 70.5 | | |
| 24.3 | 50.3 | 14.8 | 35.2 | | | 79.3 | 50.9 | | |
| 34.3 | 75.4 | 13.8 | 45.5 | | | 76.8 | 45.8 | | |
| ... | | | | | | | | | |

The underlined N-shaped layout: Calculator application (continued)

| AC | | +,- | | .,= | | x,÷ | | % | |
|------------------|------------------|------------------|------------------|------------------|------------------|------------------|------------------|------------------|------------------|
| x ₁₁ | y ₁₁ | x ₁₂ | y ₁₂ | x ₁₃ | y ₁₃ | x ₁₄ | y ₁₄ | x ₁₅ | y ₁₅ |
| 24.5 | 72 | 35.5 | 61 | 46.5 | 50 | 57.5 | 39 | 68.5 | 28 |
| x _{t11} | y _{t11} | x _{t12} | y _{t12} | x _{t13} | y _{t13} | x _{t14} | y _{t14} | x _{t15} | y _{t15} |
| 27.3 | 74.9 | 27.0 | 71.0 | 43.3 | 60.7 | 59.3 | 44.5 | 64.8 | 37.0 |
| 18.3 | 82.1 | 35.0 | 70.0 | 43.3 | 61.0 | 63.3 | 44.8 | 61.3 | 27.0 |
| 18.0 | 77.9 | 28.3 | 68.4 | 45.0 | 62.8 | 63.3 | 44.8 | 63.0 | 46.5 |
| 23.7 | 86.2 | 34.0 | 71.0 | 45.0 | 61.5 | 54.0 | 42.2 | 65.2 | 49.0 |
| 25.2 | 75.9 | 35.8 | 68.4 | 48.3 | 55.3 | 67.8 | 18.1 | 67.1 | 26.0 |
| 25.9 | 63.9 | 35.5 | 68.2 | 43.3 | 61.5 | 61.1 | 33.6 | 60.1 | 34.8 |
| 28.8 | 77.9 | 40.3 | 77.5 | 43.0 | 61.2 | 63.5 | 31.3 | 70.1 | 36.6 |
| 38.4 | 71.2 | 36.8 | 85.1 | 44.5 | 57.4 | 45.7 | 64.7 | 62.4 | 33.6 |
| 32.0 | 75.9 | 34.0 | 69.1 | 42.0 | 56.1 | 58.5 | 41.9 | 63.9 | 20.8 |
| 38.3 | 74.9 | 34.9 | 78.8 | 49.5 | 70.5 | 62.5 | 44.9 | 80.8 | 40.0 |
| 27.8 | 74.1 | 39.1 | 46.1 | 48.5 | 69.8 | 63.3 | 45.1 | 71.5 | 35.2 |
| 29.6 | 72.5 | 39.6 | 45.4 | 53.0 | 62.2 | 56.1 | 39.4 | 58.9 | 35.8 |
| 25.7 | 68.8 | 34.5 | 63.9 | 56.0 | 56.9 | 72.2 | 43.4 | 72.8 | 28.5 |
| 20.4 | 71.1 | 31.5 | 72.9 | 49.7 | 62.7 | 72.0 | 43.8 | 67.4 | 26.2 |
| 43.0 | 72.8 | 40.6 | 73.5 | 49.7 | 78.4 | 73.7 | 42.9 | 75.4 | 6.7 |
| 48.7 | 81.6 | 35.3 | 72.9 | 50.4 | 78.2 | 72.7 | 44.1 | 66.5 | 30.1 |
| 29.5 | 54.2 | 35.3 | 63.7 | 41.5 | 72.8 | 66.3 | 47.9 | 72.5 | 19.0 |
| 26.7 | 70.4 | 39.3 | 65.5 | 53.7 | 60.6 | 65.0 | 48.6 | 73.4 | 23.2 |
| 23.0 | 79.7 | 48.2 | 74.9 | 38.3 | 60.5 | 67.5 | 50.5 | 69.6 | 35.2 |
| 28.5 | 75.9 | 55.4 | 77.2 | 42.1 | 62.1 | 60.0 | 47.4 | 63.5 | 33.2 |
| 30.7 | 100.3 | 58.6 | 62.8 | 42.9 | 53.4 | 61.1 | 36.3 | 58.1 | 40.3 |
| 31.7 | 100.6 | 56.6 | 67.9 | 41.2 | 52.7 | 59.3 | 48.5 | 64.1 | 28.1 |
| ... | | | | | | | | | |

Appendix 11 Interview questions

Induction and a short interview on demographic Information and expert background

What type of work do you do?

How long have you been working in your field?

How do you come up with the layout design? How do you start?

Which layout format do you use?

Section 1: An introduction to the eyes-free interface design

Eye-free Interaction

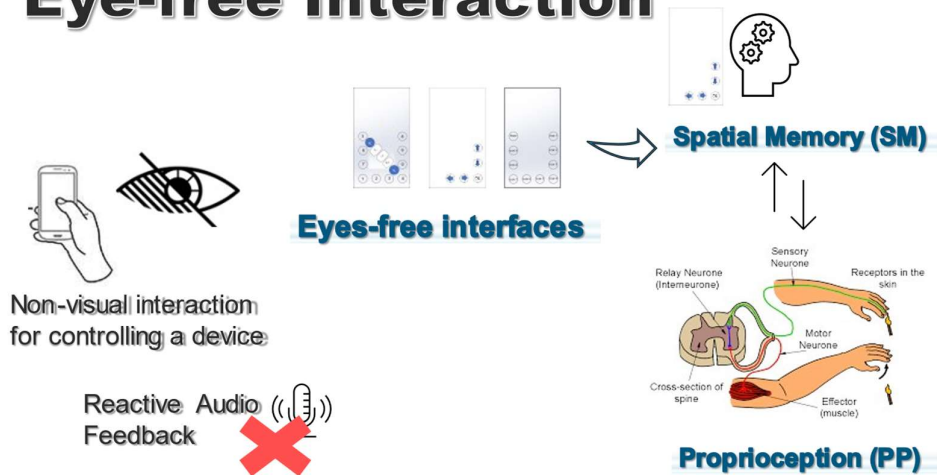

Layout design practices:

Provided that you use your dominant hand to interact on the smartphone while your eyes are on another thing. How should the icons be arranged on the touchscreen in this situation?

To design the eyes-free interface configurations for 11-15 icons, 8-10 icons, and 4-7 icons, where would you put these items on the screen?

Why do you choose that location?

Section 2: An understanding of the flowchart for the eye-free interface design process and a presentation of eyes-free interface configurations

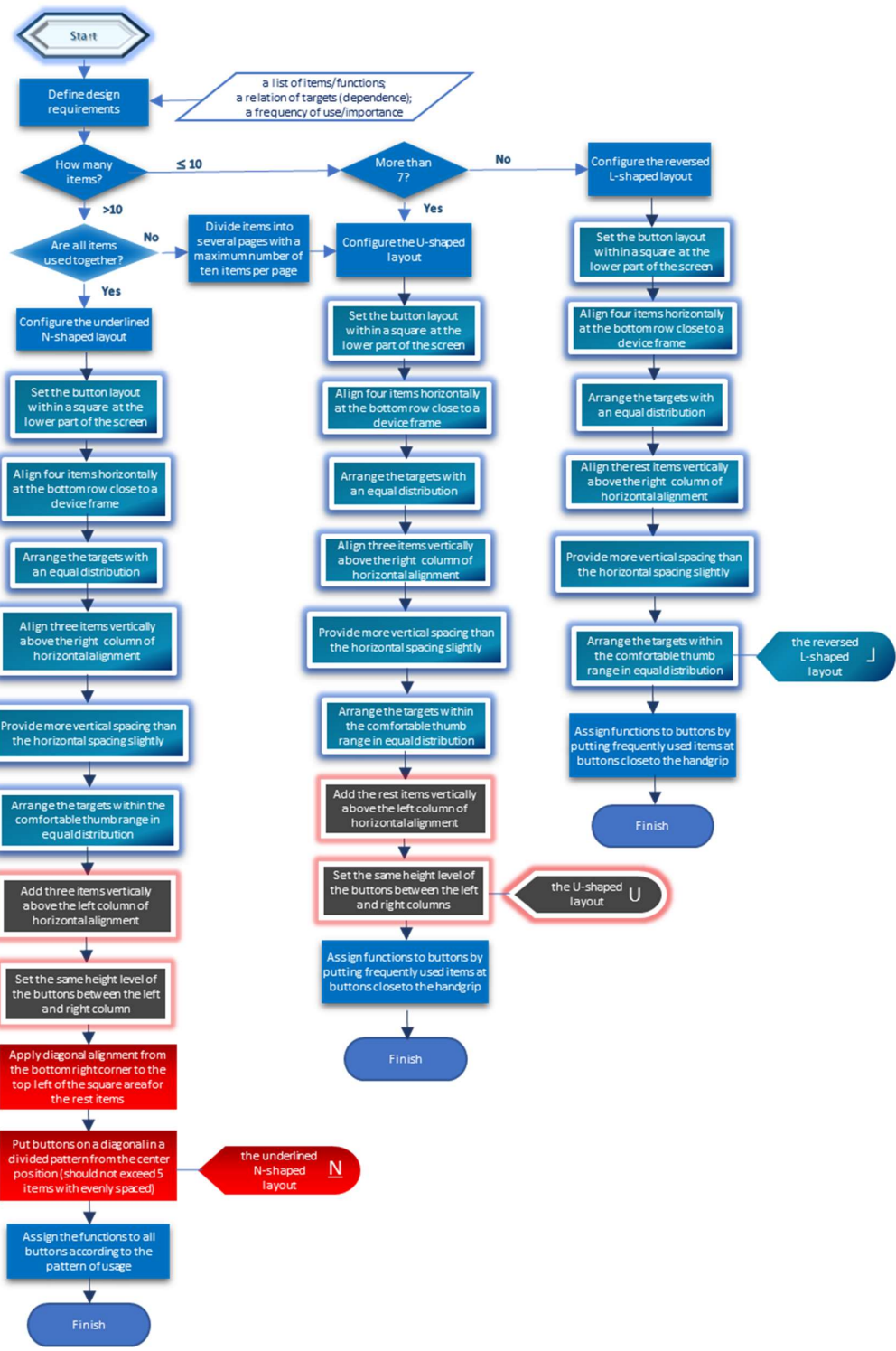

Do you understand the steps in this Flowchart?

Examples of design layouts with outcome findings on the usability test

Performance accuracy

| Input accuracy of all the control interfaces (units) | | | | | | |
|--|---------------------------|---------|------------|--------------------------|--------------|------------------------------|
| Distance Error | Session 1: Discrete tasks | | | Session 2: Arrow control | | Session 3: Serial data entry |
| | Custom | Default | Calculator | New format | Conventional | Calculator |
| Mean | 9.7 | 9.3 | 9.6 | 8.8 | < | 11.4 |
| SD | 3.6 | 2.7 | 2.6 | 3.0 | 4.6 | 4.2 |



U-shape



Reversed L-shape



Plus-shape



Underlined N-shape

Outcome Patterns

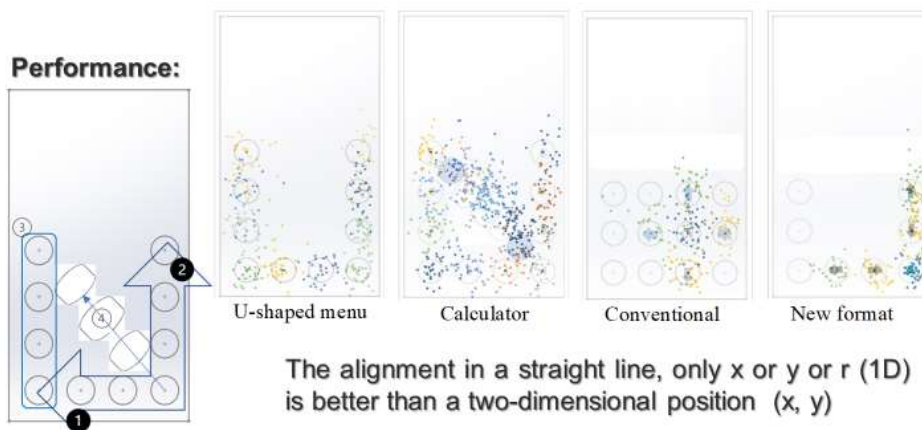

Does the flowchart provide sufficient information in designing an eyes-free interface? how?

Section 3: Insights into characteristics of eyes-free layout on touchscreen devices and a discussion of the design framework

Design Framework of Touchscreen Interface for Eyes-free Interaction

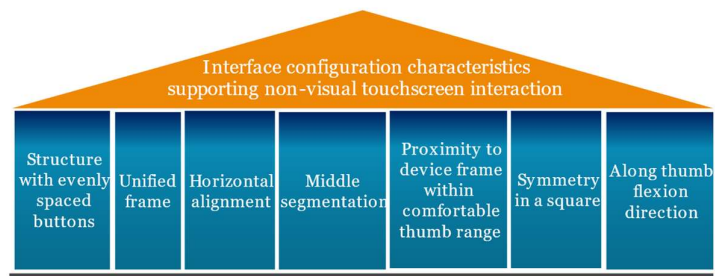

What do you think about the area or range of the button placement for an eyes-free interface? What role does the area or range of the button placement play in users' recognition and accuracy?

What do you think about the alignment of the button for an eyes-free interface? What role do the alignment of the button play in users' recognition and accuracy? How should the buttons be placed?

What do you think about the button distribution pattern for an eyes-free interface? What role does the button distribution pattern play in users' recognition and accuracy?

What role does the screen frame/device edge play in the recognition and accuracy of eyes-free interaction?

Do you think that the odd/even number of buttons affects users' recognition and accuracy? Does the middle point facilitate the spatial discrimination process of users under eyes-free interaction?

What do you think about the unified layout? What role does it play in users' recognition and accuracy?

What do you learn from the concept of spatial memory and proprioception for user perception and dexterous operation in eyes-free touchscreen interaction?

Is this conceptual framework different from your current design approach? Why? How important is this conceptual framework?

Does the framework emphasize overarching design features for designing layouts for eyes-free interaction? Is there anything that should be adjusted or added within the framework?

Is the framework useful to you as a designer? Would the aspects in this framework be a consideration you would apply when designing the interface?

Appendix 12 Interview transcript example

The following interview transcript is taken from one user experience designer. The interview was carried out in a similar structure for all designers. The questions are in bold. Interviewee responses are in standard text.

How do you come up with the layout design? How do you start?

When it comes to the design process; I start from researching the users' needs and behavior, together with gathering some business requirements. The screen layout and design methodology will be selected based on type of users, required feature (how complexity the app will become) , and the user journey. Normally, I don't strict with one layout for all design as the requirements and complexity are varied. However, there are some UX design method that I need to follow in every case such as the minimum size of the icon, font, spacing which universally affect all users and all type of the app.

Which layout format do you use?

I would use corporate wireframe templates and adjust the grid layout accordingly. Once the wireframe functionality is set, I would then move on to theme and graphical aesthetics. There are human-centred design aspects involved when choosing the correct layouts; users should be able to use them without instructions- the less steps needed to execute a task the better. Proper layouts varied across different platforms.

Provided that you use your dominant hand to interact on the smartphone while your eyes are on another thing. How should the icons be arranged on the touchscreen in this situation?

Using a smartphone without looking at the screen is prone to error risks. However, the device frame can be exploited to help the user re-orient the smartphone to the right position. The icons should be arranged close to the screen frame and within the thumb's reachable area. I would put them at the bottom-right of the screen because it is the nearest area to my palm for a right-handed person.

To design the eyes-free interface configurations for 11-15 icons, 8-10 icons, and 4-7 icons, where would you put these items on the screen? Why do you choose that location?

To design the layout for 11-15 icons, I will put these icons in the bottom row, the left, and right columns, and the diagonal section in the central area of the lower half of the screen. To design the layout for 8-10 icons, I will put these icons in the bottom row, the left, and the right columns to exploit clues from the device frame. However, the position on the top-left corner is hard to reach, so I avoid putting the icon in that position. To design the layout for 4-7 icons, I will put these icons in the bottom row first, followed by the right columns. Icons are placed on each corner and midsection on the left and right sides of the frame so that users may potentially recognise the position of the application based on the frame size while holding the device.

Do you understand the steps in this Flowchart?

Yes, I do. There are clear conditions for each case in which the layout pattern is to be used. No difficulties comprehending the logic.

Does the flowchart provide sufficient information in designing an eyes-free interface? how?

Yes, it does for UI in portrait mode as a default, covering the majority of screen frames for devices in the market. However, I would like to add up an idea for the left-hand user: if there is the case that some users are left-hand people, the guideline to create screen settings for those people would be necessary (I guess the layout shaping method would be inverted when it comes to this case. If that's correct, the guideline should be included).

What do you think about the area or range of the button placement for an eyes-free interface? What role does the area or range of the button placement play in users' recognition and accuracy?

As my current works are eyes-on interactions, it may the area of the placement may not affect the accuracy in clicking but it still plays the important role in user recognition as some buttons/gestures the users may be familiar with what they interact with in the other apps. For the eyes-free interface, putting the button within the reachable thumb area on the lower half and parallel to the screen is more proper due to near the grip position. The edges of the phone are important clues (the boundaries) for navigation as well.

What do you think about the alignment of the button for an eyes-free interface? What role do the alignment of the button play in users' recognition and accuracy? How should the buttons be placed?

The buttons should be in a straight alignment. The horizontal alignment is suggested because it is familiar to users. Their experience can guide eyes-free interaction. The alignment is also crucial for some actions such as the menu and some functions that work together. This would affect the interpretation and some actions require to be placed in the right position to give the right understanding to the users.

What do you think about the button distribution pattern for an eyes-free interface? What role does the button distribution pattern play in users' recognition and accuracy?

Designing a layout with an equal distribution pattern is suggested. This helps users in discriminating the spatial position with a low effort. The users would better memorize the pattern and apply similar stretch levels to reach aligned buttons with dexterity.

What role does the screen frame/device edge play in the recognition and accuracy of eyes-free interaction?

The usage of the screen frame/device edge is a crucial part of eye-free interaction. It allows the user to do wayfinding without looking at their phone, since they can 'feel' the physical boundary; an example of this would be to locate buttons along the mid-section or corner of the device edges

Do you think that the odd/even number of buttons affects users' recognition and accuracy? Does the middle point facilitate the spatial discrimination process of users under eyes-free interaction?

I think it affects memorisation. The middle segmentation provides symmetrical perception. The centre position in the 3 or 5 buttons layout is easy to recognise and differentiate, so it does not need much effort to reach and refer to.

What do you think about the unified layout? What role does it play in users' recognition and accuracy?

The unified layout is good as users can find out all functions and easily relate to each other spatial elements, but the interface should be configured with the proper spacing and target size to improve the accuracy.

What do you learn from the concept of spatial memory and proprioception for user perception and dexterous operation in eyes-free touchscreen interaction?

Spatial memory helps you indirectly recall the interface patterns without really looking at the screen. Proprioception trains your hand and fingers to be used to the patterns so you can interact without a need to pay visual attention. It's a useful concept to apply in screen design. Together with the right implementation, it would create easy interaction for the user even without eyes-on.

Is this conceptual framework different from your current design approach? Why? How important is this conceptual framework?

Yes, it is different because currently most apps are designed for visual interaction. This framework is interesting as it suggests an effective layout design under a reduced level of visual attention.

Does the framework emphasize overarching design features for designing layouts for eyes-free interaction? Is there anything that should be adjusted or added within the framework?

The framework is applicable for eyes-free interaction. Haptic feedback (vibration) could also be added to inform the user's response.

Is the framework useful to you as a designer? Would the aspects in this framework be a consideration you would apply when designing the interface?

Yes, it is useful. Although I might not have a suitable use case to apply this framework in my work right now, it's considerable to include the framework to design effective interfaces for dexterous operations design under a reduced level of visual attention. However, users might not be familiar with the layout and may find it a bit hard in the first place as they need to remember a new pattern. Thus, it should start by designing the app from a simple layout (4-7 icons) and then the number of icons can be added up later when the user is accustomed to it.