

**Design of the Rehabilitation Glove : a soft
wearable robotic device for repetitive hand
rehabilitation therapy after a stroke**

Sylvain Hosatte (201491685)

SEP 2015

Department of Biomedical Engineering
University of Strathclyde

This thesis (14500 words) is submitted in partial fulfilment of
the requirements for the degree of Master of Science in the
Department of Biomedical Engineering

Declaration

This thesis is the result of the author's original research. It has been composed by the author and has not been previously submitted for examination which has led to the award of a degree.

The copyright of this thesis belongs to the author under the terms of the United Kingdom Copyright Acts as qualified by University of Strathclyde Regulation 3.50. Due acknowledgement must always be made of the use of any material contained in, or derived from, this thesis.

Signed:

Date:

Acknowledgement

First I would like to thank my supervisor Dr. Wei Yao for his guidance and his global support during the whole project and the chance I had to work on the great topic that are exoskeletons, which has always be my motivation to follow engineering studies so far.

I would also like to thank Stuart Biggar, a PhD student of the Biomedical Engineering Department, and John MacLean, technician in the electronic lab of our Department, for their advices and kind presence when I was having troubles constructing the prototype of Rehabilitation Glove.

Finally, It is only thanks to my friends that I was able to keep my head cool and face this exercise without being overwhelmed by stress.

Abstract (290 words)

Stroke is the major cause of disability in the world today, and it touches up to 110 000 persons every year, only in UK, and up to 70% of the survivors of a stroke suffer from a moderate to severe disabilities in their upper-limb motion control, caused by damages in the cerebral motor areas. The recovery of post-stroke impairments is a hard and long treatment, because the patient has to recover his physical strength and functionalities, but he also needs his affected neural area to reorganise, in order to make significant progresses. The rehabilitation techniques are many and all of them have their pros and cons, but the physiotherapists have more and more troubles in handling the growing number of patients. Indeed the majority of the patients suffering from a stroke are aged over 60, and the global ageing of the population implies an increase of those disabled people, creating a work load and a cost too great for the conventional rehabilitation techniques. The aim of this project is to investigate upper-limb rehabilitation techniques, and in particular robot-assisted rehabilitation, to find out what could solve this major issue. The existing devices will be reviewed and robotic rehabilitation devices pointed as a solution for future post stroke recovery therapy. The concept of a soft robotic glove for hand rehabilitation, coupling a flexible structure with a cable-driven actuation will then be developed, and the methods of design of a prototype will be followed. Both the mechanical coupling between the hand and the glove, using vacuum and suction cups, and the control interface of the prototype will be developed. Finally, despite the only partial achievement of the prototype, future prospective and use for this device will be discussed, concluding on the promising results obtained.

Table of Contents

I	Introduction	1
II	Literature Review	6
II.A	Strategies for Upper-Limb Rehabilitation.....	6
II.A.1	Overview of the different rehabilitation programs.....	6
II.A.2	Additional treatment methods.....	11
II.A.3	The patient and his training environment.....	12
II.B	Robot Assisted Rehabilitation.....	16
II.B.1	Features of robotic-assisted therapy.....	16
II.B.2	Review of existing devices	20
II.B.2.1	Manipulandum robots	20
II.B.2.2	Exoskeleton robots	23
II.B.3	Results of robot assisted therapy	26
II.B.4	Hand Exoskeleton and "soft" robotic devices	29
III	Design of the Rehabilitation Glove	32
III.1	The Soft Exoskeleton Structure.....	32
III.1.1	Base exoskeleton technology	32
III.1.2	The vacuum glove solution	33
III.2	Rough mechanical model and kinematics of the vacuum glove	36
III.2.1	Kinematics of the glove.....	37
III.2.2	Vacuum strength	39
III.2.3	Simplified mechanical model of the glove.....	40
III.3	Actuation of the glove	42
III.3.1	Choice of the motors	42
III.3.2	Architecture of the actuation	44
III.4	The construction	45
III.4.1	Realisation of the glove	45

III.4.2	Realisation of the motor support	48
III.4.3	Criticism of methods and remarks.....	49
IV	Control Interface	51
IV.1	Specifications and Control Interface.....	51
IV.1.1	Specifications of the device	51
IV.1.2	Control Interface and choice of components.....	52
IV.1.3	Objectives and Program first draft	55
IV.2	Communication between components	57
IV.2.1	Control Interface and choice of components.....	57
IV.2.2	Power Supply	59
IV.2.3	Other components of the circuit	61
IV.3	Programming the Arduino	64
IV.3.1	Detection of the analog button state	64
IV.3.2	Button timer	65
IV.3.3	PWM outputs.....	66
IV.4	Circuit realisation	67
IV.4.1	Full electrical circuit	67
IV.4.2	Test phase	68
IV.4.3	Circuit soldering.....	69
V	Results and Discussion.....	71
V.A	Prototype results	71
V.A.1	The prototype's state	71
V.A.2	Vacuum test.....	72
V.A.3	Flexion test	73
V.B	Discussion.....	74
V.B.1	Apparent weaknesses.....	72
V.B.2	Encouraging prospects	72

Conclusion	76
List of References	77
Appendices	85
APPENDIX I. Hand Rehabilitation Exercises	i
APPENDIX II. Specs Sheets	iii
APPENDIX III. Circuit.....	iv
APPENDIX IV. Program	vii

I - INTRODUCTION

Background

There are about 15 million people suffering a stroke per year according to an estimation of the World Health Organisation, and 110 000 in UK only. More than 80% of them survive the acute phase, but most of the survivors get through muscular control disorders, such as hemiparesis. The motor areas of the affected hemisphere are damaged, resulting in a defective motor unit recruitment [Gemperline et al, 1995], a higher excitability threshold of the neural system, impaired spatial and temporal patterns of muscle activation, lower MEP produced by active contraction and electrical stimulation, and lack of coordination between the different joints. The lack of stimulation of the affected limbs' tissues then usually leads to contractures and muscle spasticity, muscle atrophy and joints mechanical stiffness [Friden et al,2003].

All those syndromes strongly affect the gait, posture, and general functions of the patients. Up to 70% of the patients can get their arm and hand muscular control affected directly after the stroke [Van der Lee et al, 1999]. Hand fine motion in particular requires a lot more neural control than locomotion, for example[Lin et al, 1999] and fingers muscles are deeply affected by post-stroke complications, making a satisfying recovery often longer and more difficult. The grasping movement and coordination of the fingers are such a problem that even after several years of rehabilitation, some patients are still struggling to achieve simple daily tasks like toileting or using door handles, sometimes remaining permanently affected [Cicinellia et al, 1997]. On average, 45% of stroke patients do not manage to

recover enough in the first 6 months to perform those simple tasks and the layout of the patients' living area is still a big part of the handling of the stroke consequences, removing architectural barriers and adjusting the environment to a person with muscular weaknesses [Dobkin et al, 2004 ; Molier et al, 2012]. Even if those adjustments are necessary most of the time, especially for older patients, they are restraining the patients for further progress and independence.

It has been long thought that most of the recovery, spontaneous and due to rehabilitation, could only be achieved in the first year after the stroke [Van der Lee et al, 1999 ; Biitefisch et al, 1995], and even if studies now allow to think that progress is still possible after this period [Dobkin et al, 2004], it is very important for the patient to focus his rehabilitation efforts as soon as possible after the stroke. The active recovery process depends on several aspects, the brain have to reorganise, while the muscles mechanical characteristics have to be improved in order to follow correctly neural control. Two studies suggest that best progresses are supposed to start eight weeks after the beginning of the treatment [Lieperta et al, 1998 ; Cicinellia et al, 1997], when a significant enlargement of the hand cortical outputs occurs, along with great clinical progresses of the patients. These results were obtained combining a mapping of the motor cortex with transcranial magnetic stimulations (TMS) to attest neural activity, the Ashworth modified scale to evaluate muscle tone, and clinical tests like the Action Research Arm (ARA) test to give a score to basic hand movements like grasping, pinching and gripping, making the recovery quantitatively observable [Carroll et al, 1965 ; Lyle et al, 1981 ; Van der Lee et al, 2001]. Equivalent tests for the locomotion or postural functions evaluation also exist, even if more frequent and accurate studies are carried on the arm function recovery [Busse et al, 2004].

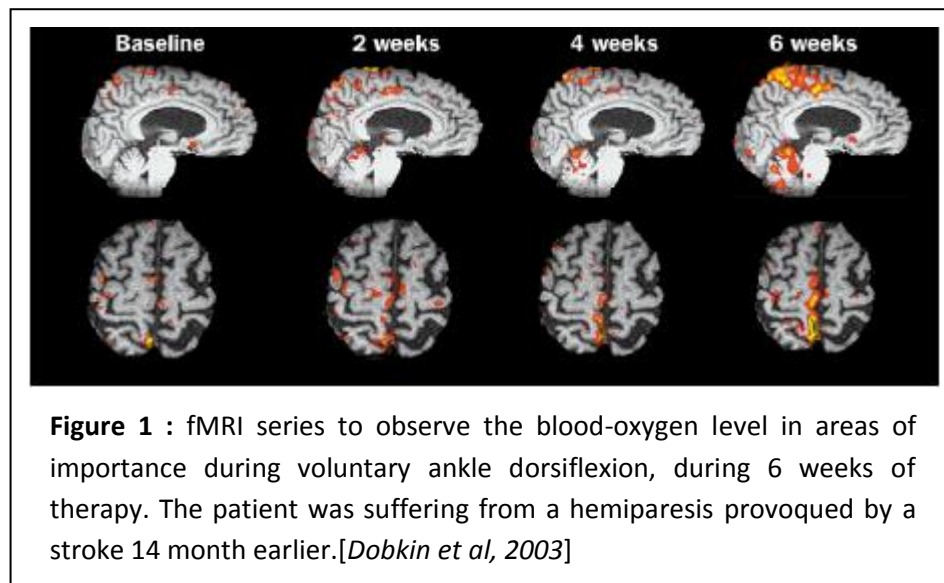

The patient whose MRI pictures are shown in **Figure 1** started a 6 weeks therapy to improve his walking skills, and after 12 sessions he had achieved successful improvements, so he wasn't suppose to continue the therapy, but after seeing the progression of the cerebral activity thanks to the MRI, the clinicians offered the patient to extend the treatment of two weeks, during which the patient gained even more control and about 20% more move speed. This result is a good example to show that functional improvement are possible after more than a year, and also show the strong correlation between cerebral motor areas activation and clinical progresses.

Aims and Objectives

This project has two main goals. The first is to show the interest of exoskeletons and wearable devices, and in particular the need for soft, lightweight robotic devices, in the field of post stroke rehabilitation therapy, through a literature review and comparison of the different rehabilitation techniques. The second is to develop a justification for the

design of the soft exoskeleton we imagined, as well as a step-by-step follow up of the construction of the prototype, and then to produce a satisfying proof of concept with the results of the prototype in various functional tests.

Thesis Overview

Chapter II : Literature Review

The chapter II is a review of the different techniques that are used to achieve or facilitate neuromuscular recovery of the upper-limb after a stroke, which will tend to show the particular interest of robotic assisted therapy in this field. Follows a description of the features of robotised rehabilitation treatments, and a list of the existing devices that are the most cited in the literature, with detail of their technologies. After reviewing the results of those devices, with a particular interest for the exoskeletons, we will introduce the concept of "soft exoskeleton" and its promising characteristics for the future of robotic assisted rehabilitation therapy.

Chapter III & IV

These chapters develop the design methodology adopted for the Rehabilitation Glove. The mechanical and electrical choices will be explained and justified with theoretical models and experimental data. Due to the short period of time allocated to the project, a particular accent is put on the fact that the design is as much as possible made to be improved by future projects. The detailed steps of the construction of the prototype will be shown, with remarks and criticism towards some methods or parts that were used for matters of time and convenience.

Chapter V

The state of the prototype at the project deadline will be illustrated by pictures and a brief appreciation of the few tests carried out. Then a discussion to give insight on the reasons of the few downsides of the prototype, and an opening on the promising future of this device.

Conclusion

II - LITERATURE REVIEW

II.A - Strategies for Upper-Limb Rehabilitation

II.A.1 - Overview of the different rehabilitation programs

Conventional therapy

The average classic rehabilitation of a patient is about 10 hours per week, during at least four weeks [Oujamaa et al, 2009]. It is usually carried on with 1 to 2 hours sessions of training in a specialised medical centre. The therapy includes manual dexterity training, with simple exercises like grasping balls or manipulating small objects. The physical recovery is focused on strength and balance reinforcement, with weight bearing activities, as well as stretches to help reduce the tissue contractures. It also often contains teaching sessions about strategies to handle daily living tasks, most of the time promoting the use of the sane arm [Wang et al, 2011].

A special effort is made on repetitive therapy, to help the patients know their training exercises and for them to become automatic. The repetition of key movements also have a very positive effect on the early reorganisation of the affected brain hemisphere neural mapping [Biitefisch et al, 1995].

Generally, the therapy choose to develop slow but precise or strong movements, and avoid fast contractions movements because they tend to reduce the muscle tone and often induce non wanted movements, spastic reflexes and a general lack of precision.

Some basic rehabilitation exercises are presented in the **APPENDIX I**.

Specific additional rehabilitation programs

Three different RCS studies tested different rehabilitation therapies, such as the ARM Basis training, the Bobath method, or the Constraint-Induced movement (CIM) therapy, on a basis of fifteen to twenty hours per week in addition to the conventional rehabilitation. It appears that those specific training programs were not giving significantly better results in terms of gained functionality or improved mechanical results at the end of the treatment, but a better general spatial control of the whole limb is observed, and the acquired performances are lasting longer than with conventional repetitive therapy [Winstein *et al*, 2004 ; Platz *et al*, 2005 ; Wang *et al*, 2011]. The type of specific therapy has also been found to have more impact on the patients' improvements than the time of training added, supposing a necessary, standard duration of treatment [Platz *et al*, 2005]. We will present the different specific therapies cited just above, and give more details about the results of several comparative studies testing those treatments on randomised samples of post stroke patients.

Bobath concept

The Bobath concept therapy aims to address both neural and non-neural causes to the disability of the patient. Its bases have been established in, and it is still one of most clinically used rehabilitation philosophy. Its validity is frequently put in question and recent studies continue to affirm its legitimacy [Graham *et al*, 2009 ; Winstein *et al*, 2004 ; Platz *et al*, 2005].

The design phase of the treatment is the essence of the concept. The goal is to assess the degree of impairment for different activities, to understand the neurological or mechanical cause of the impairment, and then design a treatment with activities that will target those

precise causes, and finally integrate those activities in a program of repetitive daily tasks the patient would realistically face at home. It stimulates the patient interest and allows him to multiply the time of the therapy without a direct load for the therapists of the rehabilitation centre. The strength of this concept is that it is constantly enriched by scientific progresses in the understanding of neuromuscular control and neural system spasticity after brain injury. The clinicians can adapt the program with the best modern strategies and activity sets.

ARM Basis training

This therapy aims on the long term to allow the patients to have a good dynamic control and multi-joint coordination of their affected arm, with three main phases of training. First, the patients will train selective joint movement, one by one and multiple times, while being given feedback by therapists about their overall dynamic motions and their posture, as well as help to perform motions too difficult for the patients. Then, in a second phase, all these exercises will be repeated, but with the rest of the arm immobilised, for the global control not to have any incidence on the training of every separated movement. The final phase is to train more complex movements needing multi-joint coordination, while using weights and straps to help stabilise the posture of the patient during movements [Platz *et al*, 2005].

Constraint induced movement therapy

The base of the therapy is to restrain the use of the sane arm, to encourage the patient to execute his daily activities with the affected limb. Constraint-Induced (CM) movement therapy has the same goals as the Bobath concept in terms of focusing on both physical and cortical recovery, and also by integrating the training in a activities of daily life. The aim is for the patients to make progresses that will stay the most beneficial for them on the long term [Oujamaa *et al*, 2009].

The patients are asked to wear a sling to restrain the sane arm movements, and keep it as much as possible during the day, except for toileting, sleeping or activities that could be dangerous, like shaving, ironing and cooking. It avoids the "learned non-use" of the affected limb, which a lot of patients develop during rehabilitation, getting used to accommodate simple tasks by handling them with only their sane arm, reducing drastically their chances of functional recovery, and their autonomy [Lieperta et al, 1998]. The daily activities are detailed in the different movement they make execute to the patient, and after the patient is being taught how to handle them in a beneficial way for the recovery of his arm, and has to repeat series of simple tasks while at home.

The therapy, also referred as "forced use" therapy has very enthusiastic results in terms of the independence it gives to the patients in their life after the therapy, on the long-term, while the improvements brought by other treatments tend to decrease quicker, once the patient ends being in touch with the physiotherapists and his regular training [Winstein et al, 2004]. It corrects a lot of unwanted spastic movements, and improves the patient posture [Ploughman et al, 2004], because they are used to practice a whole gesture, and not to only focus on small exercises in a single position.

It also has the big advantage to allow patients to have several hours of additional treatment, 20 to 25 on average [Oujamaa et al, 2009], without adding a supplementary work load on rehabilitation professionals, leaving them available for other patients.

On the downside, this treatment can only be accessible for patient still possessing a certain control and strength in their affected limb. The most severely affected patients will probably have to get through a lot of more conventional and facilitated rehabilitation before reaching the level of autonomy required to achieve CI therapy[Biitefish, 1995 ; Winstein et al, 2004 ; Platz et al, 2005]. About 68% of the patients who were interviewed in

a study [Page et al, 2004] were immediately discouraged by the idea of CIM therapy. It is partly due to a lack of confidence of the patients in their capacities, and also a lack of motivation about spending practically all their time out of the rehabilitation centre training, and struggling with every simple task at home, with few resting times.

But as discriminative as CI rehabilitation can be, this treatment can still be a way for patients having already achieved conventional therapy to go back to training to make further progresses, even after a period of break.

Summary

The following table is a quantitative summary of the data gathered in all the comparisons studies cited in the **part II.A.1**. The different parameters observed are the number of hours of therapy per week, the functional improvements made on three level : postural control, basic movements and fine movements coordination, the dynamic characteristics (force and speed) acquired, the impact on short-term of the treatment, and the need or not of the assistance of a therapist to follow the training program.

	Hours per week	Arm postural control	Hand Basic Movements	Fingers Coordination	Dynamic movements	Long-term	Therapist required	Comments
Conventional Therapy	10-15	+	+	=	=	=	Yes	
Bobath concept	+10-15	++	++	+	=	+	No	Good patient independence after treatment.
ARM Basis	+15-20	+	++	+++	+	=	Yes	
Constraint-induced movement	+20-30	+++	++	+	=	++	No	Good patient independence. Very demanding treatment . Can provoke shoulder pain[42].

Table II.1 : Qualitative comparison of different upper-limb rehabilitation methods after a stroke, as early treatment (2 months after stroke) or as a re-training (up to one year after stroke), going from 4 to 8 weeks of therapy, with patients of an average age of 55 to 65 years old.

II.A.2 - Additional treatment methods

Transcutaneous Electric Nerve Stimulation

Transcutaneous electric nerve stimulation (TENS) is present in a lot of rehabilitation programs, often in the beginning of the training session, or during active simple exercises like flexion of the fingers around a rubber ball. The stimulation are comparable to the one that are used to strengthen muscles after a long immobilisation. The results of this method are disputed. While the stimulation may help to achieve active contraction exercises, the outcome of TENS at the end of the treatment seems to depend of the time spend doing electrical stimulation. In the study [*Biitefish et al, 1995*], where a group was administrated TENS two times a day, 15 minutes each time, the evaluation of their recovery did not bring significantly better results than the control group, after 4 weeks of treatment. But an early experiment on the use of TENS, administrated for one hour every day, gave more satisfying results, including an increased muscle tone in the arm, and improvements of dynamic motor factors [*Oujamaa, 2009*].

Thermal stimulation

Thermal stimulation is a method to help the recovery of proximal motricity in early stroke rehabilitation, where patients are asked to react to thermal uncomfortable stimulations by taking their arm away from the source of heat or cold [*Chen et al, 2005*].

Mirror therapy

Mirror therapy, which was used at first to treat phantom pains, is starting to be introduced in paretic limb rehabilitation therapy. The patients execute simple flexion and extension movements with both their arms, while hiding the paretic limb in a box, and having a mirror reflecting the image of the sane arm's movements, in place of the hidden affected arm.

Two RCS studies display results of mirror therapy in addition to conventional rehabilitation, for two 4 weeks trials and a population of eighty patients in total. The use of mirror therapy, on a base of approximately 30 minutes per day, at home, would have a particularly good effect on fingers coordination movements, more than on the global arm control [Dohle et al, 2008]. While those improvements are not often preserved on the long term [Yavuzer, 2008], both studies suggest that continuing mirror therapy as a daily activity after the clinical rehabilitation period would probably be very beneficial to the patient.

Those two studies are encouraging, but their results are disputable because of fluctuations concerning the time at which the treatment was started after the stroke, or the precise amount of time every patient spent to practice the mirror therapy [Busse et al, 2004]. Several studies are though considering it as a promising method to facilitate recovery, and we should see further studies appear in a close future to properly attest the validity of the process.

II.A.3 - The patient and his training environment

Feedback

Feedback is an important part of a rehabilitation program and comes in many forms during the treatment. The clinical feedback of the therapists is usually the main form of feedback to help the patient to understand what he is doing, why, and give him comments and directions along the therapy. As a source of mistake correction and encouragement to improve, it is indispensable, but it requires the attention of the therapists on one patient at a time. This is why virtual environment systems are appearing to provide guidance and critics to the movements made by the patients, and more and more sensor devices are

connected to the patient during training to directly give a quantitative feedback. An example is the Rutgers force feedback glove that can give the patient information about fingers' flexion angles or grasping strength, for example [Bouzit *et al*, 2002]. An immediate feedback is always motivational, it stimulates the challenge spirit the same way that speed displayed by gym bikes or the running distance displayed by the electronic watch of a jogger.

The sensory feedback of the patients is often damaged in their affected limb, and exercises stimulating the proprioception of the patient by addressing physical resistance or obstacles to his exercises, like a pattern of blocks a patient must avoid while moving his arm through them [Casadio *et al*, 2009], will generally enhance the short-term results of the therapy, and help the patient retrieving familiar sensations of interactions with the affected limb, better than if we imagine a virtual-reality only practice environment.

Finally, in terms of motion coordination, visual feedback is essential, and it often becomes a dependency when the motor and sensorial system is affected, as after a stroke incident. More than a tool, it is a requirement to allow patients to get back their sense of proprioception [Bonan *et al*, 2004], but if an attracting or stimulating visual environment is provided, with the help of games and augmented reality, the outcome of the treatment will only be improved, in addition to the patients' motivation.

Motivation

Following a motor rehabilitation treatment is very demanding, and is strongly dependant of the patient's implication. Most of the recovery's requirements are based on the regularity of the patients and their good execution of all the exercises they have to do. Plus, the majority of the patients concerned by post-stroke rehabilitation is over 60 years old, which

in addition to the supplementary physical burden that physiotherapy represent, may be discouraged of involving too much effort in the treatment if they are not already very active, which can be very damaging to their recovery process [Maclean et al, 2000]. Not only if the patients believe in the rehabilitation and the professionals, will they be more able to understand the exercises and trust their therapists, but they will also often get a more precise attention from their doctors, thanks to their positive attitude.

The moderately motivated patients, for their part, will tend not to be very regular in their home exercises, and more easily let a negative state of mind set up, focusing on the bad elements of the situation and the downwards of the treatment rather than looking for rewarding improvements. Consequently, they will be less involved, and may receive less feedback from the care personnel around them, which can easily create a vicious circle for a poorly motivated or a depressed patient, depression being the most common psychiatric complication after a stroke, striking up to 30% of the patients [Lenzi et al, 2008].

Independence

The therapists make special efforts in making every exercise accessible to the patients, by using rehabilitation equipment to facilitate the tasks, and providing assistance, but a common conclusion of the studies on rehabilitation techniques is that most of the rehabilitation programs are not adapted to the most severely impaired patients. Those can't achieve most of the training by themselves, and require special attention from the therapists and a longer treatment. The average length of therapy can be extended to 50 hours per week of conventional rehabilitation only [Oujamaa et al, 2004], and it seems hard to realistically fit a great number of those patients in the schedule of physiotherapists.

In all the rehabilitation strategies described in **part II.A.1**, the accent is particularly put on trying to get the patient to do repetitive exercises and make him understand and master them, so that he can increase the number of repetitions, train more efficiently, and with more autonomy. The patient, when achieving improvements himself, not only requires less therapists taking care of him, but also improves faster, and with better long term effects than a completely assisted. Integrating daily life activities in the treatment, that the patients execute themselves at home, also aim to increase the future autonomy of the patients, to make them self sufficient after the rehabilitation is over.

The independence of the patient is both a goal of the rehabilitation, and a training method, and the development of techniques that allow the patient to train alone, with no further needs of assistance and feedback, will probably be the future bases of rehabilitation care. Most of the latest studies now focus on three different fields which, when they are effectively coordinated, may bring new perspectives to post-stroke rehabilitation therapy. The next era of post stroke care is most likely to rely on Virtual Reality training environments, Bio-Feedback systems, and Robot assisted therapies. We will now review in detail the field of robot assisted therapy, then develop the integration of bio-feedback systems, and virtual reality environments in robot assisted therapy.

II.B - Robot Assisted Rehabilitation

II.B.1 - Features of robotic-assisted therapy

Robotic rehabilitation has many aims, trying to reduce both the time and cost of the therapy, decrease the work load of the therapists, alleviate the intensive physical work the patient has to provide, and also enable new modes of exercise [Lum et al, 2002]. There are already a lot of different rehabilitation robots, but they often share some basic training features, which we will describe now.

Active-aided movements

The robot provides a mechanical assistance to the patients spastic arm to help him achieve the target movements of the rehabilitation. It allows weak patients to have a proper rehabilitation training, making very early post-stroke rehabilitation possible. The start of a robotised therapy can now take place only a week after the stroke occurred and even less [Masiero, 2007]. It also allows the most severely impaired patients to practice exercises that would either be too hard to conduct or requiring too much assistance from the therapists. The assistance provided by the robot system is adjusted depending on the level of impairment and the progresses of the patient through the therapy, generally decreasing to a minimum possible or even to zero. In fact, the goal should be to always aim the minimal assistance making the movement available to the patient [Casadio et al, 2007]. It is believed that the more the movement intention is carried by the patient, the better the impact is on their recovery [Casadio et al, 2009]. The patient are thus strongly encouraged to make the most of the effort by themselves, the same way as electrical nerve stimulation is often carried while actively contracting the muscles [Lazzaro et al, 1998]. Most of the robots are still used under the watch of therapists, their viability and integration to

rehabilitation programs being studied, so generally the clinicians can check whether the patients receive the adapted assistance from the robot or not, and decide to modify it at will.

Passive movement practice

The patient's affected arm is at rest and the robot directs the whole target movement. It has been said earlier that a forced movement with no implication of the patient was most likely to have no particular impact on his functional and mechanical recovery, but used punctually, in addition to the other modes of training, it can be beneficial. When we were describing the consequences of the stroke (Introduction), we raised the issue of tissue contractures and joint stiffness occurring after a stroke, especially in the extremities of the limb, creating a passive mechanical resistance to every movement. A study on the effects of active and passive restraints implied in the rehabilitation exercises tried to use passive displacements of the limb to decrease the tissue and joints resistances [*Hesse et al, 2003*], which was proven to be very useful. It would have an impact similar to a massage and stretch of the affected limb, making the joints work and relaxing the surrounding tissues. The passive movement practice could actually be a very beneficial part of the treatment to conduct before starting the work on active muscle contractions or during the breaks between exercises or during different movements, to relax the muscles that were at work and prepare the ones about to be used in the next exercise.

Active-restrained movements

The robot acts as a resistance to the goal movement of the patient, just like a patient would use some strings to work his hand flexion and reinforce his muscular strength, but the robotic interface enables to do this with more complex movements, following the limb and

acting as a viscous fluid resistance for example [Casadio et al, 2006]. It helps a lot the patient to develop his muscular strength and master the movement he is training.

The force feedback in the arm of the patient also stimulates the sensorial neural system of the affected limb, and allows the patient to work on his proprioception skills. In this extent, the patients can be encouraged to perform closed-eyes training [Casadio et al, 2009], to try to only direct his movement with the force return of the arm and his visualisation of his arm's position. This applies mostly to movement implying the whole arm, because the fine movements of the fingers are harder to recover for most patients.

Instant feedback and follow-up

The robotic devices used in rehabilitation are made with a great number of actuators, but also a real web of sensors around the affected limb, in order to fulfil several missions. First, it allows to control the forces exerted by the robot on the patient, measure the position of the joints in real-time and ensure the safety of the patient is not put at risk by the robot [Lum et al, 2002]. As the robot-aided rehabilitation is available to the most severely impaired patient, the more data is controlled and the less risks are taken to ask a too demanding physical burden, and fatigue can be controlled.

It also allows to record a lot of data about the patient's muscular characteristics and neural stimulation. These data can then be used to attest quantitative improvements of the patients and follow up the therapy without further investments of time by both therapist and patient. By studying correspondences between the functional tests like the Ashworth Scale or the Fugl-Meyer arm test and the limb's mechanical characteristics, this quantitative evaluation can even give an overview of the functional improvements of the patient, and

serve as a good control tool to attest the progresses of the patient's recovery [Hesse *et al*, 2003].

The real time measurement of the arm's strength is also often used as a motivational feature. The forces and torque scores of the patient during a movement are displayed on a screen in front of him, and it induces a challenge compartment of the patient, trying to surpass himself and to see his progresses every session. For example, for the training of the reaching movement, the distance the patient reaches is displayed the screen at every try [Cassadio *et al*, 2006] and the patient always try to increase the distance he can reach.

Virtual training environment

As it often difficult to both being tied to a robot device and interact with objects around for the patient, a lot of robot-assisted rehabilitation programs are using a virtual reality environment to give a context to the movement exerted during the training [HealthPact™, 2014]. It consists in a screen displaying a cyberspace in which the trained movements are often included in motivational games, as a game of targets the patient is encouraged to reach to gain points depending on the distance of the target. The patient interacts in this cyberspace with the sensors that are placed on the robotic interface, and the force feedback provided by the robot serves as the return for the interactions in-game. Another type of game is the mimic, where the patient has to imitate the movement displayed on the screen, which stimulates the mirror neurons of the patient [Iacoboni *et al*, 2009]. The virtual environment is appreciated by the patients as it creates a nice distraction to the very repetitive aspect of the rehabilitation therapy, that often decreases the motivation of the patient.

Thus, if the games proposed are developed a bit and the robotic interfaces evolve to more portable devices, it will be easier and easier to develop an efficient at-home rehabilitation for the patients, the robot providing assistance, guidance, motivational support and follow-up of improvement.

II.B.2 - Review of existing devices

To fulfil all the aims of robot-assisted rehabilitation, and alongside with the evolution of technology and the researchers budget, several designs of rehabilitation robots have been created. We will now draw a list of the different kind of robots cited in the literature, describe the technology used and the characteristics of the rehabilitation carried by these robot categories.

II.B.2.1 - Manipulandum robots (planar robots)

This kind of robot only has one contact point with the patient, usually the extremity of the robot. It is often a handle the patient grasps or a support on which the patient's forearm is attached. These robots thus apply forces only at the contact point, which doesn't promote pluri-muscular coordination, and often gets very targeted results on the neuromuscular areas worked by the training, while not developing much the others.

❖ MIT-MANUS (*figure II.2*).

This robot was developed in the MIT in the early 1990's, and took around 11 years to be fully operational. Most of the studies in the literature review still call it the MIT-MANUS robot, but it has been renamed "In Motion" robot.

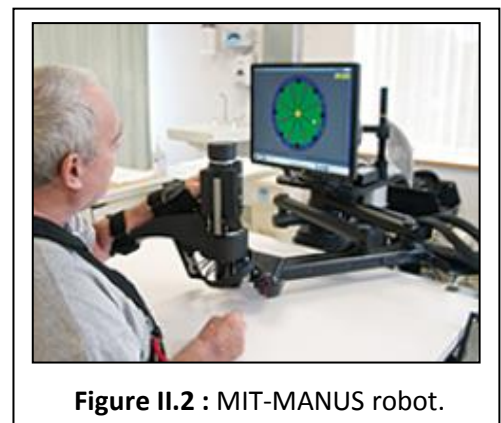

It is a 2 DOF robot authorizing the use of the shoulder and the elbow motions in an horizontal plane. It does not force a rigid trajectory to the patient, by allowing an elastic deviation around the programmed movement. The level of precision can be adjusted so that on a low impedance it is very easy to move. It allows both active constrained and active aided modes of training. It is a reference in robotic rehabilitation because it has been existing for a long time and it is the only robot with studies carried over several years and a great number of patients. [Flash et al, 1985]

❖ Braccio di Ferro (*figure II.3*).

The Braccio di Ferro is another horizontal plane motion robot, focusing on the reaching movement of the patient. The training is also active aided or active-constrained, and is based on the reaching of virtual pieces that the patient sees on a screen in

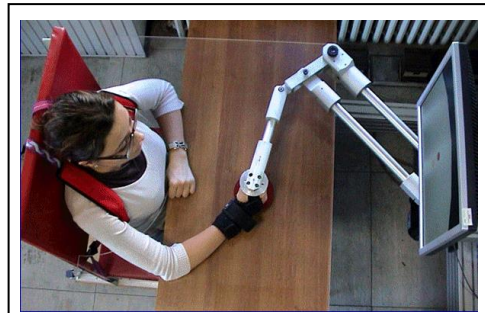

Figure II.3 : Braccio di Ferro robot.

front of him. It has been reported that the patients are often asked to do some closed eyes training to try to reach the target, as explained in **part II.B.1**.

❖ Assisted Rehabilitation and Measurement Guide (ARM-Guide) (*figure II.4*).

The ARM-guide, developed in the Rehabilitation Institute of Chicago, is made of a handle mounted on a linear motorised slide that will assist the patient's movement. The slide itself is mounted on a 2 rotations system that allows a lot of 3D variations of the movement direction. It basically allows movement in an adjustable vertical plane. It hosts the same modes of training than the MIT-MANUS,

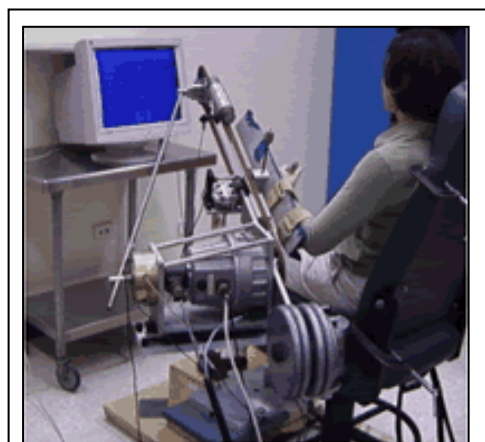
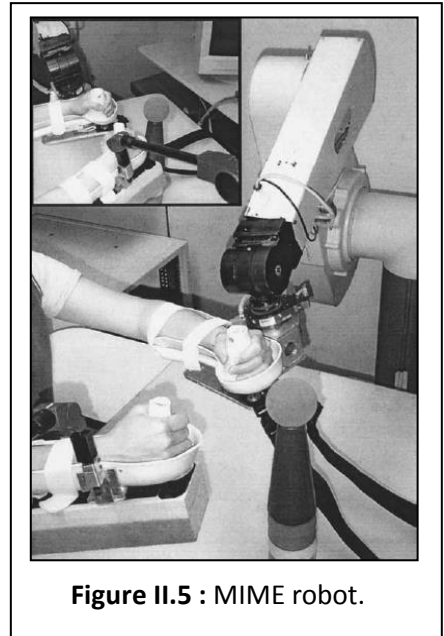

Figure II.4 : ARM-guide robot.

and also records the forces generated by the hand on the handle.[Kahn et al, 2006]

❖ Mirror Image Movement Enabler (MIME) (figure II.5).

The MIME system is a bimanual robot developed in the University of Stanford, and based on an industrial robot (Puma 562). It's particularity as a "manipulandum" robot is that the contact is made on the whole forearms of the patient, which are strapped to reinforced sling structures, which are both coupled with a 6 DOF force and torque sensor system. With a few measurements, an approximate elbow and shoulder joint positions are calculated and estimations of the force and torques at the



joint are calculated and displayed in real time by graphics on a screen. In addition to the usual training modes, the MIME robot allows to use the sane arm's movements to help guiding the affected arm symmetrically, stimulating the mirror neurons of the patient [Lum et al, 2002].

❖ NEREBOT (NEUro REhabilitation roBOT) (*figure II.6*).

Nerebot is a cable-suspended rehabilitation robot. The patient has his arm at rest in a sling suspended by cables wheeled on independent gallows. Each cable is thus motorised and the Nerebot allow to control 3D trajectories in space, to assist the patient in early rehabilitation training. It is well adapted to the first phases of treatment because it can be used in a

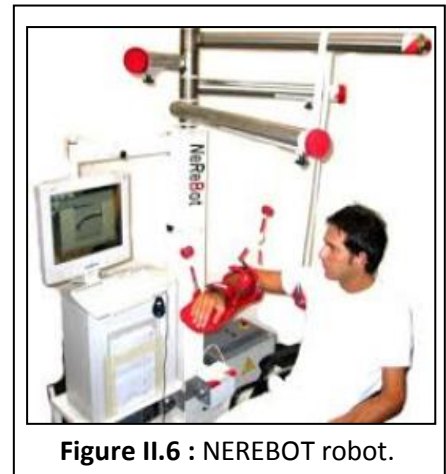

Figure II.6 : NEREBOT robot.

wheelchair or in a hospital bed. The Nerebot has been renamed Maribot after several simplification of the gallows system[Rossi *et al*, 2007]

II.B.2.2 - Exoskeleton robots

This category of robot is characterised by its versatility. They can possess a wide range of DOF, different target joints (wrist, elbow, shoulder), and their technology (cable driven, gears, link rods...). One of the advantage of an exoskeleton is the ability to be less bound than with a fixed work station. The coordination between different muscular areas and the postural control are better. They generally are able to provide assistance for more range of motion of the whole limb than the first category of robots we described. On the less bright side, most exoskeletons available nowadays are quite big and heavy to carry, and require the patients to be in a good shape to use them, on contrary with the work station which does not require additional effort from the patient.

The control of exoskeleton device is also more and more biosignal-oriented. In addition to monitor the kinematics of the patient and the forces he develops, the measuring of EMG signals with surface electrodes is becoming more and more common [Mulas *et al*, 2005], to attest the muscular activity of the patient, but also as control of the robot movements. This is due to our better understanding and recuperation of the EMG signals through non-invasive methods.

❖ MGA (Maryland-Georgetown-Army) Exoskeleton (figure II.7).

This exoskeleton has 5 DOFs electrically actuated. The particularity of this robot is to offer a wider space of work by taking place on the patient's scapula. The control interface adapts to the patient's kinematics to assist his movements without blocking them.



Figure II.7 : MGA Exoskeleton.

❖ Caden-7 (figure II.8).

The CADEN-7, developed in the University of Washington, is made of a base controlling 4 DOFs around the shoulder and the elbow, and a module on the forearm to control 3 DOFs at the wrist. Several force sensors are positioned between the two parts of the robot for a clear understanding of the arm's

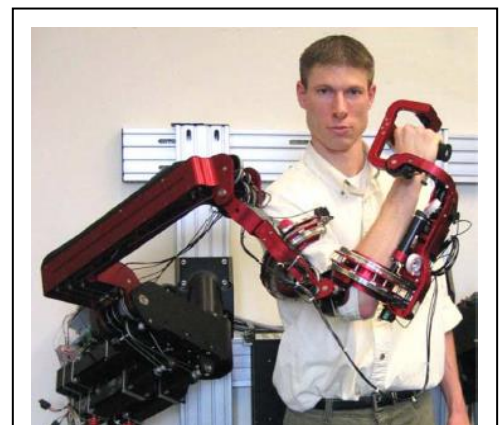

Figure II.8 : Caden-7 Exoskeleton.

position. The elbow flexion/extension is EMG controlled since improvements have been made on the robot in 2007 [Perry et al, 2007].

❖ Delaware Cable Exoskeleton (*figure II.9*).

This exoskeleton has a particular structure, made of several bracelets linked together by several cable pairs, making it very light and adaptable to different morphologies of arm. The adaptability is often a problem with exoskeleton devices, due to the particularities of the shoulder and elbow position.

The cables are actuated by several electric capstan winches, and by moving the bracelets, the flexion and extension of the elbow is controlled. The command is though very complex and the mechanical choices of the actuation seem disputable,

as it seems like the arm cannot be flexed without applying strong axial forces [Jarassé, 2010].

❖ Rupert Exoskeleton (*figure II.10*).

The Rupert exoskeleton possess 5 DOFs, 2 in the shoulder, 2 in the elbow and one in the wrist. It is one example of exoskeleton that uses pneumatic actuation, which gives him a very good strength/weight average and a very good safety and compliance for the patient. But the defaults of the pneumatic actuation also apply to this device, the forces generated are quite low, as well as the joint speeds. Plus, the work space is limited by the range of the pneumatic actuation [Gopura et al, 2011].

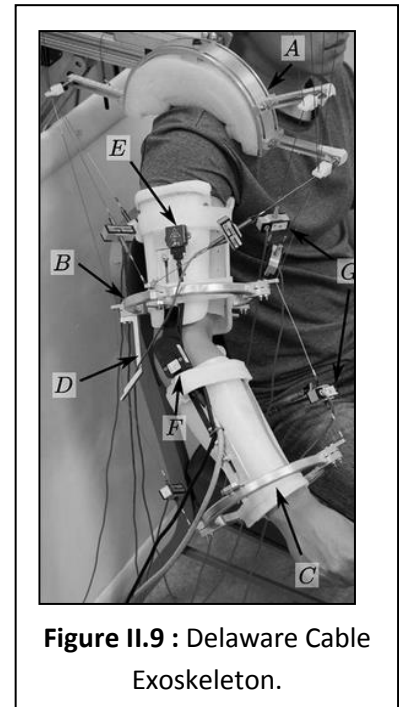

Figure II.9 : Delaware Cable Exoskeleton.

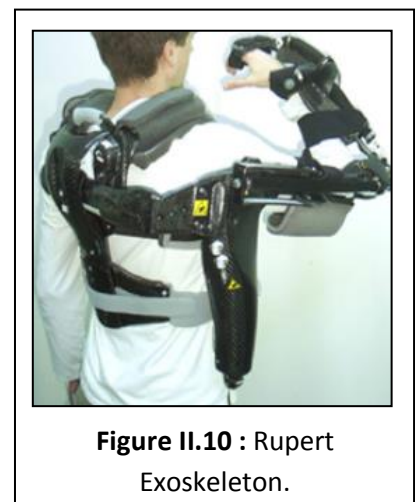

Figure II.10 : Rupert Exoskeleton.

❖ SUEFUL-7 Exoskeleton (Saga University Exoskeleton For Upper-Limb) (*figure II.11*).

The SUEFUL robot allows 7 DOFs by combining two formerly independent modules of 3 DOFs for the wrist and 4 for the shoulder and elbow. It allows the control of the entire arm, and the junction between the two modules has been designed adjustable, so that the exoskeleton can adapt to different persons. The exoskeleton is though quite voluminous and heavy, and the ROM of the shoulder is quite limited.

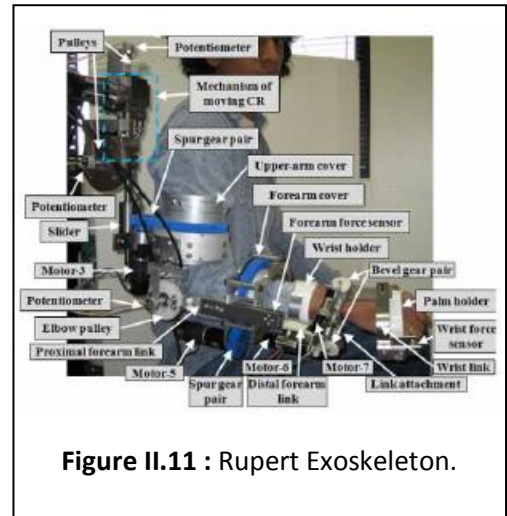

Figure II.11 : Rupert Exoskeleton.

The team that designed the SUEFUL is currently testing their EMG-driven control interface on sane patients [Jarassé *et al*, 2013].

II.B.3 - Results of robotic-assisted therapy

Robotised therapy takes place with various intensity of treatments, from 1 to 20 hours between the different RCS covering the field. It is still mostly an additional therapy to conventional rehabilitation treatment.

In several studies, the robot groups did not seem to make significantly better functional improvement than the control groups of patients [Casadio *et al*, 2006; Reinkensmeyer *et al*, 2000 ; Reinkensmeyer *et al*, 2009], but the patients in the robot group often get really interesting muscular improvements, as shown in **fig.II.12**.

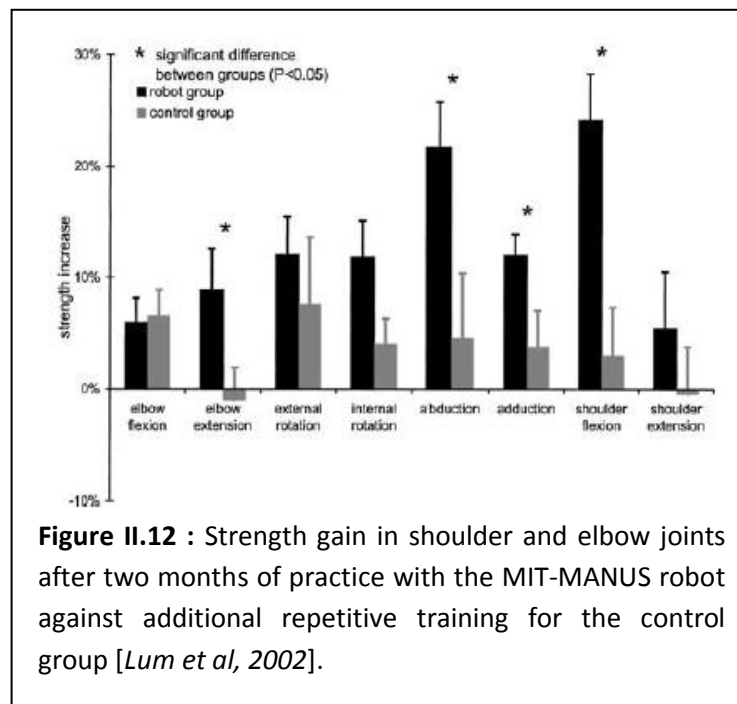

In this study involving 27 patients, the robot group was also progressing up to 4 times faster than the control group in their strength increase. But we can also notice that the joints that were obtaining better results are those which were specifically trained by the patients on this robot. It is in fact a common result of robot-assisted therapy, the improvements are often only noticeable in the precise area that was worked by the robot. It is thus important for the robot assisted therapy to only work in addition to conventional therapy, or the robotised therapy must allow more different exercises to have a real overall effectiveness.

The success of the therapy is most likely to be caused by the very high number of moves that are practiced in a short amount of time [Kwakkel et al, 2007], more than the specific exercises available on the robots. But as a result, robot assisted improvements are quite infamous for their lack of long-term impact. It is not rare that studies conduct a 6 to 12 months follow up after the robotised therapy, and the practice of very repetitive therapy only has proven non-favourable to a lasting cortical network reorganisation [Casadio et al,

2009]. Most of the times, the additional improvements the robot group of a study acquired decrease after 4 to 6 months.

On the other hand, this assisted therapy allows the patient to perform more complex movements, which improve their multi-joint coordination and the smoothness of the trained movements.

The subjective results are also very positive when the patients are asked what effects they feel about the therapy. Most of them answer that the robotised therapy, in addition to relieve the burden of a long conventional treatment, was giving them confidence and trust in their ability to perform difficult movements [*Hesse et al, 2003*].

For now, the advantages of the robotised therapy are promising, but not yet particularly obvious, because most of the devices are still in development and are used under the supervision of the therapists, but in the context of active-aided movement training, it seems realistic with the number of research team working on the development of robotic assisted therapy to imagine in a close future a robotic device that would record the forces and torques provided by the patient, and by analysing his progresses, adapt automatically the assistance provided by the robot to the affected limb, with exceptional regards to the patient's safety. Due to the advances in the field of human biosignals recording and analysing, the EMG for example, it is most likely that the next generation of rehabilitation robots will be driven by human biological signals input and self-sufficient, adapting the therapy. The robots that started to be developed ten years ago are just starting now to provide evidence of viability and usefulness to reduce the work load of therapists, the physical burden of patients, and increase the possibilities of the rehabilitation.

II.C - Hand exoskeletons and "soft" robotic devices

The devices aiming to treat the hand of post-stroke patients in particular are quite rare. All the robots shown in part II.B.2 were not filtered to avoid hand rehabilitation robots, but the literature holds not much hand robot or exoskeleton cited in big comparative studies or considered in a RCS on a population of patients. Carrying a deeper research with the key words *hand robotic rehabilitation stroke*, *hand exoskeleton* and *hand wearable rehabilitation device*, few, but interesting hand robotic devices have finally emerged :

❖ Anthropomorphic Robotic Hand (*figure II.13*)

A 20 DOF cable driven robotic hand, which tries to reproduce as much as possible the geometry of human joints for the finger articulation, copying the action of the tendons with the cables, to actuate precisely the hand [Xu et al, 2013].



Figure II.13 : Anthropomorphic Robotic Hand.

❖ Rutgers Feedback-glove (*figure II.14*)

The hand module of a full arm haptic interface [Bouzit et al, 2002], the terms of force feedback imply a sensor based glove that delivers a positive force feedback to the hand of the patient. The Rutgers



Figure II.14 : Rutgers Master II Feedback Glove.

Master 2 has an interesting, lightweight, pneumatic actuation system, but does not seem very convenient to use for most of the fingers movements. Its range of motion is quite low due to the limits of the pneumatic cylinders.

❖ EMG-driven Hand Exoskeleton (*figure II.15*)

This exoskeleton was prototyped in the Artificial Intelligence and Robotics Laboratory of the Polytechnic school of Milan, Italy. Its structure is based on a glove that has been plasticised to bear a part of the charges induced by the robotic assistance. The device is cable-driven to achieve hand full flexion, with springs on top of the hand to produce a resistance to movement [Mulas *et al*, 2005]. The assistance is probably adjustable, to give a proper muscular training to the hand. This kind of advanced prototype is very rare for hand rehabilitation devices, but sadly, no further trace of it has been found in the literature, ten years after this article.

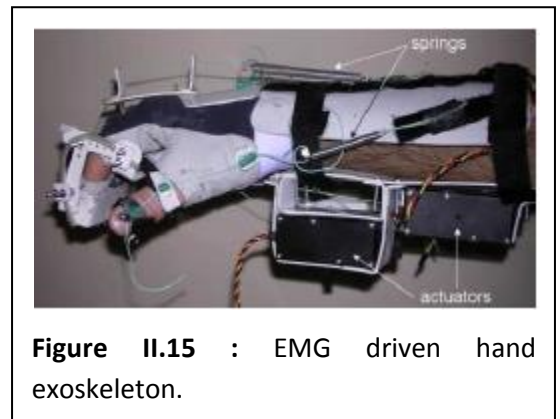

Figure II.15 : EMG driven hand exoskeleton.

❖ Prototype of pneumatic wearable device for hand rehabilitation (*figure II.16*)

This prototype, developed in the Department of Control Science and Technology of the Huazhong University of Science in Wuhan, China[Xing *et al*, 2009]. This is a pneumatic actuated device, with the particularity of having a soft actuation interface, which solves quite well the problem of range of motion that often occurs with pneumatic actuators.

This prototype also actuates the thumb, which is way more complex than actuating the other fingers, and is designed for home rehabilitation. It is meant to record the patients progresses and unexpected behaviours for a frequent follow up by the therapists treating the patient.



Figure II.16 : Soft pneumatic wearable hand rehabilitation device prototype.

All the results of this literature research are prototypes, often realised in university technology departments. None of these robot is yet developed enough to conduct a clinical survey on its viability, but this is a sign of the path the robotic therapy has been slowly taking, developing more and more self sufficient robotic devices, as simple and safe of use as possible. It is exactly the goals our Rehabilitation Glove aims to reach. It is also a warning, showing that the only way to work on the development of a prototype for this kind of device, is to see the long term objectives and work on a segmented project that can be carried over by following researchers or students.

III - Design of the Rehabilitation Glove

We want to create a soft exoskeleton robotic device to assist hand rehabilitation therapy after a stroke. The goal is to create a light, wearable, glove-like system, which would be able to provide assistance to the patient for simple fingers flexion and extension movements. For matters of time, we designed the prototype for hand flexion only, but the design can be easily adapted to hand extension.

III.1 - The Soft Exoskeleton Structure

III.1.1. Base exoskeleton technology

Our device must be able to flex four fingers of the hand with a maximal range of motion, as it has been decided to avoid the complexity of the thumb movements and leave it for a further stage of development. The Rehabilitation Glove is thus supposed to possess twelve DOFs, but every phalanx is not controlled individually, the main interest is to reach the maximum flexion of the fingers. We also want to avoid any rigid structure that would add weight to the glove and be a hindrance to the glove flexibility. Finally, as the device is designated to the hand rehabilitation only and as an additional therapy, the design aims to a device as simple and cheap as possible, that could be easily affordable for therapists and even for an eventual home therapy use by the patients.

It is quite naturally that the choice of technology oriented itself to a cable driven system, identical in concept to many robotic hands [Folgheraiter et al, 2000]. A cable is fixed at the tip of the finger and pass through pieces of the exoskeleton attached to every phalanx of the hand, so that when the string is pulled at the base of the hand, the fingers are flexed, as shown in **fig.III.1**. It is one of the simplest fine actuation system for the fingers movements, as a copy of the human tendons [Xu et al, 2013] .

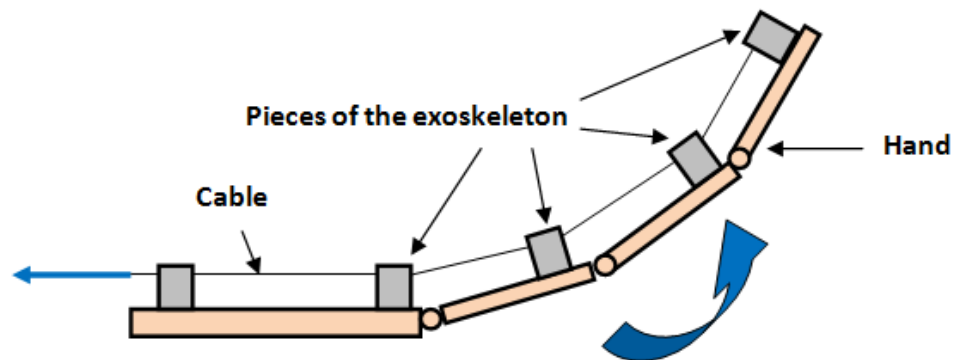
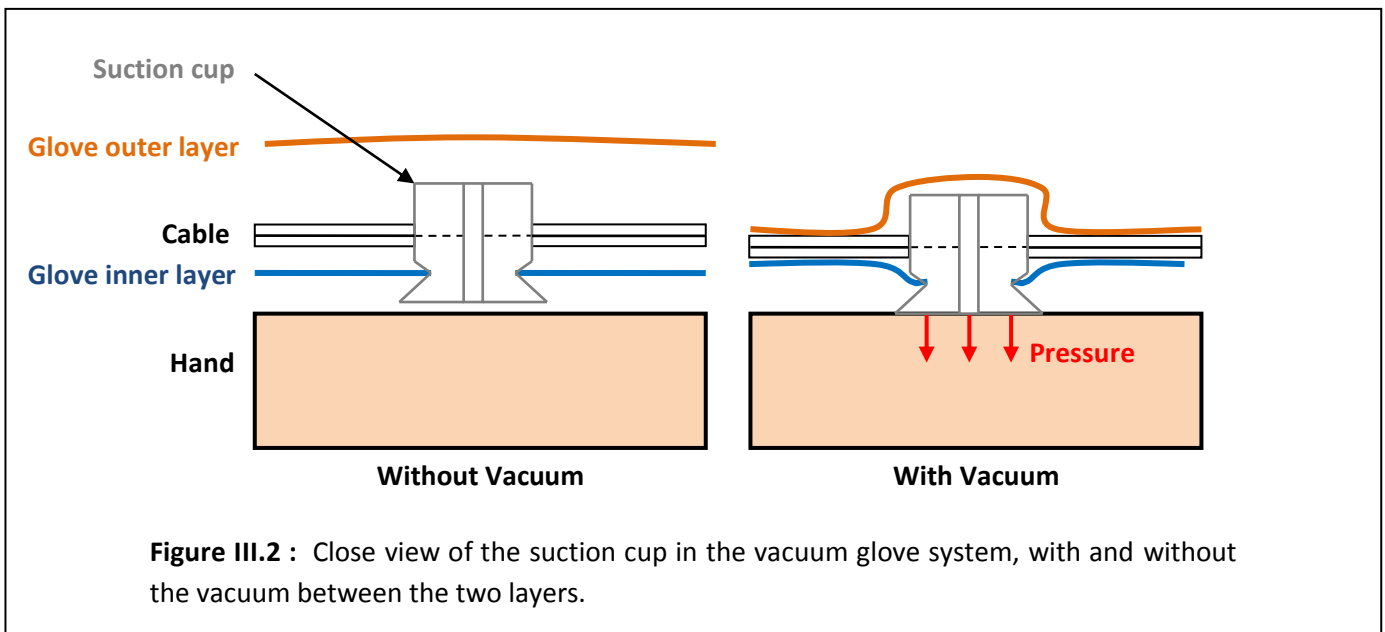

Figure III.1 : The cable driven system, and the flexion of the hand as a consequence of the cable being pulled.

The challenge was then to create a structure that would be rigid enough to hold the artificial "joints" the cable pass through, but keep the rest of the glove completely flexible.

III.1.2. The vacuum glove solution

The structure of the glove only needs punctual pieces that will stay in place and act as artificial joints to guide the cable while the rest of the glove stays flexible. The chosen was to use small suction cups as guide for the cables. The 8mm diameter cups would be in contact with the hand of the patient at the necessary points, while their other side ends in a sealed chamber made by two superposed rubber gloves. Making the vacuum between those two gloves would stick the suction cups to the hand, allowing them to act as guides for the cable, while keeping the glove flexible. **Figure III.2** and **III.3** show schematics of the vacuum glove system with a close view on the suction cup and then a more general view . The specs sheet of the suction cups we chose is available in **APPENDIX II**.



The cable is protected by a very small diameter plastic tube. This way, when the vacuum is made and the two layers of gloves stick to each other, there is no friction of the cable against the rubber gloves. The suction cup is glued to the rubber glove inner layer, making sure the junction is as air proof as possible.

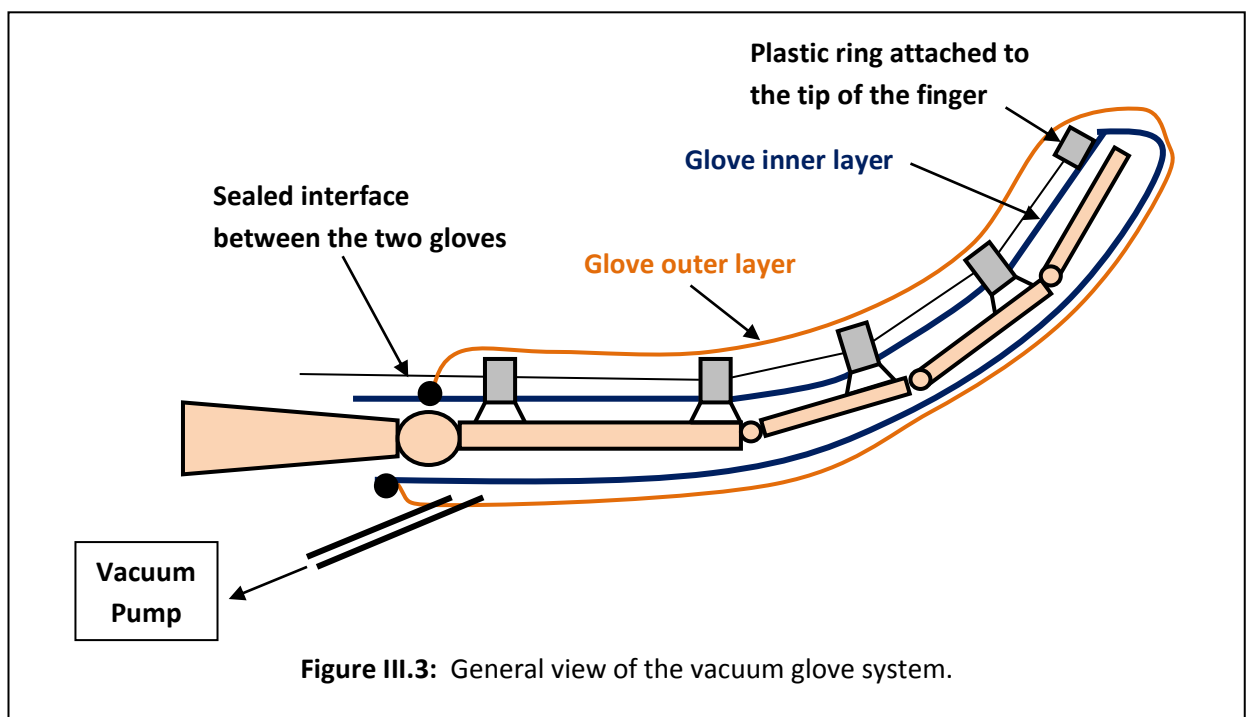

The interface between the two gloves also has to be completely sealed and air-proof, as well as the junction between the outer glove and the tube leading to the vacuum pump.

The choice of the glove was more difficult than expected. It has to be air-proof, with a layer as thin and flexible as possible. The most suitable materials would probably be rubber, PVC and coated neoprene, which are all used in a wide range of glove applications. But considering easily available gloves for privates, only a few gloves categories exist : the electrical risks gloves, which even in their lightweight models are too heavy and too rigid, PVC chemical risks gloves, that were not tested because of their price, but which would probably be close to our needs, and the basic rubber gloves, which even if they can seem weak, are exceptionally light, flexible, and close to the skin. In the end, standard rubber gloves were chosen, they are highly likely to support the forces at stake in the Rehabilitation Glove and constitute a cheap solution, easy to work, replace and use for the building of the prototype.

The last parameter adjustable is the place of the suction cups on the hand. They must be stuck at the best places to guide the cable, but also on parts the palm where the skin do not move too much during hand flexion, to keep the suction cups well in place. The final position of the cups in the palm is shown by the pictures in **fig III.4**.

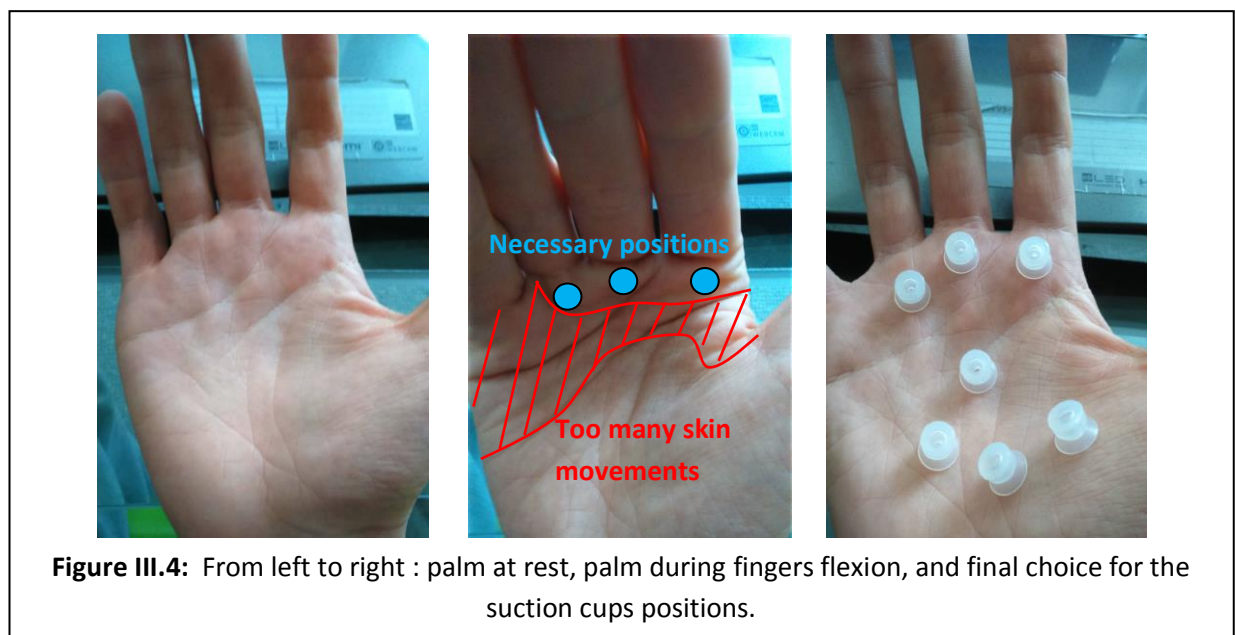

For the suction cups on the finger, the only problem is to allow the maximum range of motion for the flexion, with one cup on every phalange. In **figure III.5**, it is shown that the distance between the cups on the intermediate and on the proximal phalange (IP and PP) is important for the final flexion of the finger, due to the height of the suction cup.

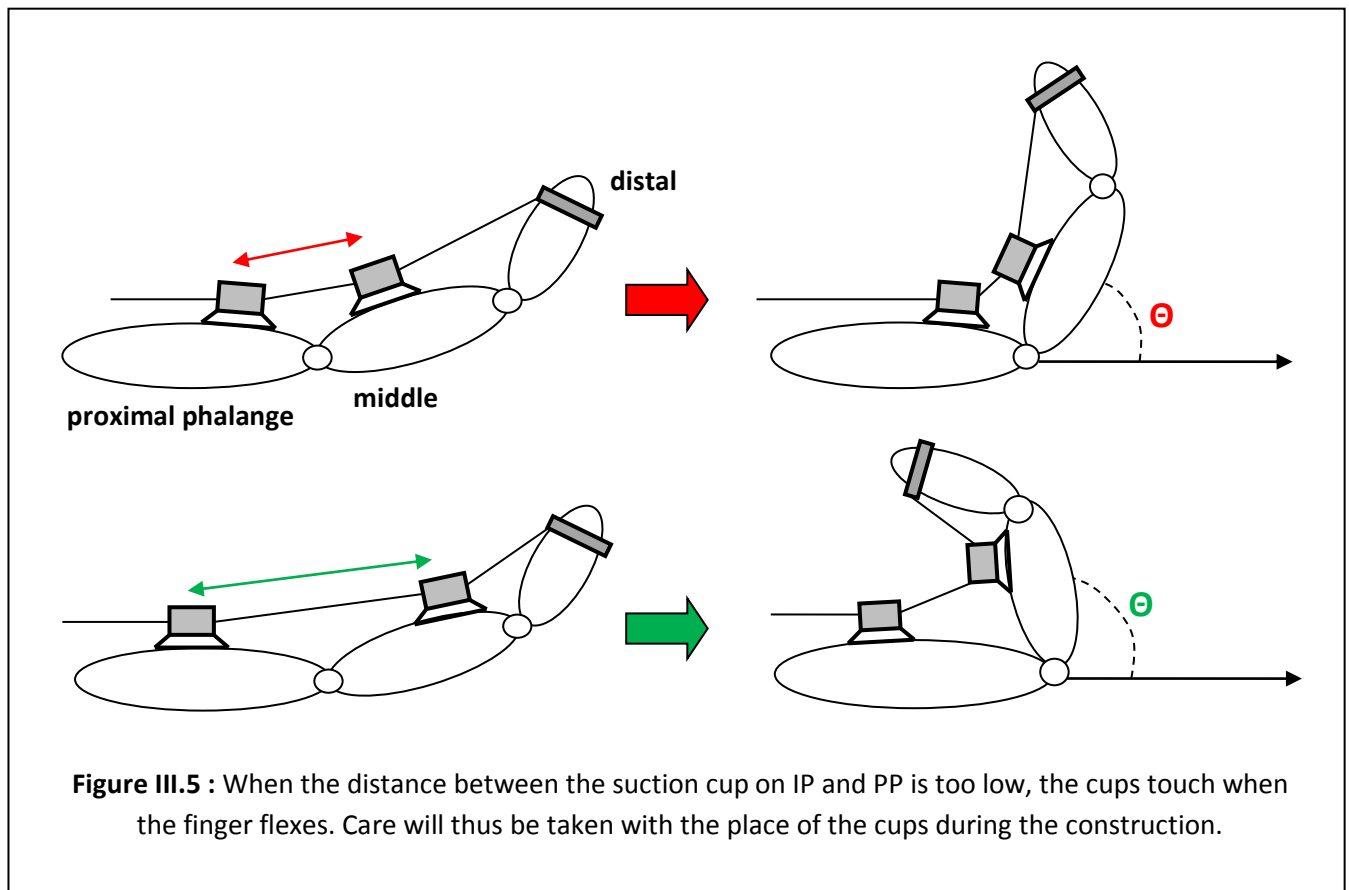

III.2 - Rough mechanical model and kinematics of the vacuum glove

Three points will be addressed in this part : draw the kinematics of the device to get an overview of the device dynamics, as well as a first estimation of the range of motion (ROM) provided by the Rehabilitation Glove, attest the force of the suction created by the vacuum to chose a model of vacuum pump, and finally, get an estimation of the forces in the hand and the traction force necessary to flex the patient's fingers.

III.2.1. Kinematics of the Rehabilitation Glove

In the **figure III.6**, a first schematic has been drawn of the glove's kinematics in relation to the fingers flexion angles. The joints of the finger are named Metacarpo-phalangeal joint (MCP), Proximal inter-phalangeal joint (PIP) and distal inter-phalangeal joint (DIP), which flexion angles are labelled respectively θ_1 , θ_2 and θ_3 .

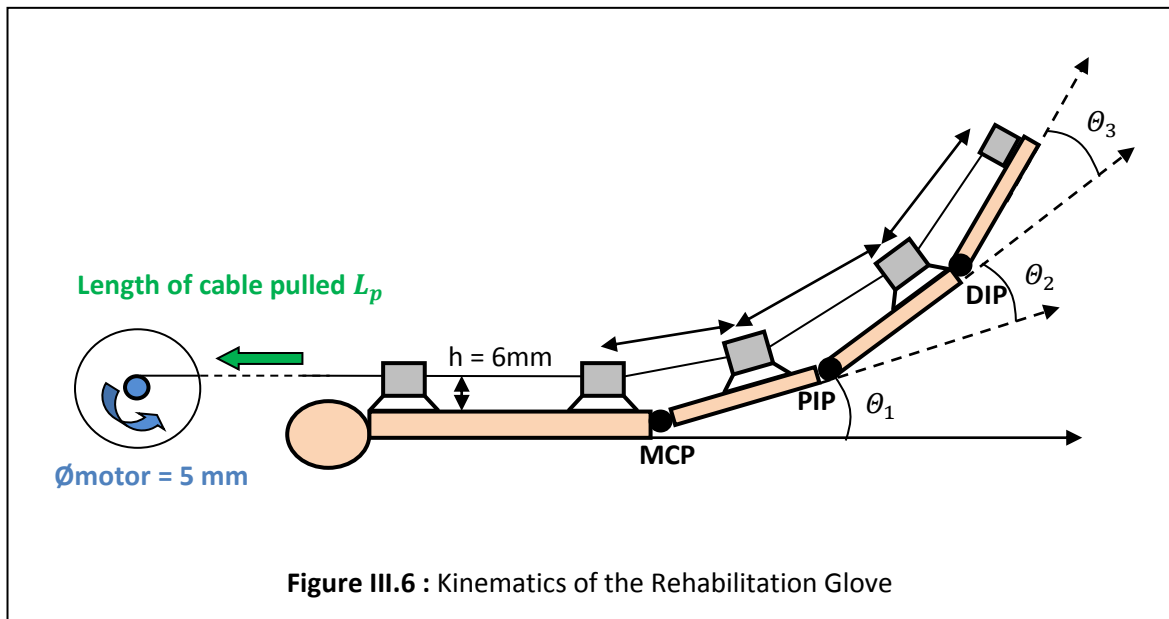

θ_1 , θ_2 and θ_3 were graphically measured in the case of full hand flexion using a picture of the researcher's hand flexed, taken from the side :

Angles (°)	Flexion
MCP (θ_1)	90
PIP (θ_2)	110
DIP (θ_3)	60

Table III.1 : Inter-joints angles during hand flexion.

Making a theoretical calculation of the equation linking the angles θ_1 , θ_2 and θ_3 and the length of cable pulled L_p is very complicated, as the angles θ_2 and θ_3 are already linked by a second order equation.

The degree of flexion of the different joints vs. the length of cable pulled has been estimated through a simple test : using a few plastic collars and a piece of cable, the flexion of the index via cable driven actuation has been simulated and recorded. There is a marker on the cable ,as well as a ruler in the working space, so that the length that has been pulled is always known. A few print screen then served to measure the different inter-joints angles in different positions of the finger. Some sample pictures are shown in **fig.III.7** and the results are in the **Table III.2** below. The test was carried a few extra times to make sure the results were consistent.

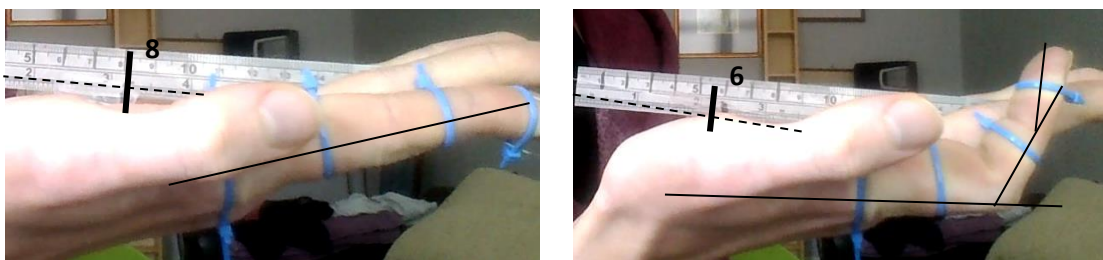

Figure III.7 : Sample pictures of the test, at rest and with 2cm of cable pulled.

L_p	0	10	20	30	40	50	60	70	80
MCP (θ_1°)	0	0	0	0	5	20	45	75	85
PIP (θ_2°)	0	40	64	85	100	105	105	105	105
DIP (θ_3°)	0	0	13	30	35	35	35	35	35

Table III.2 : Experimental results of θ_1 , θ_2 and θ_3 vs. L_p (in mm).

With this, the length of cable to be pulled to achieve full flexion was estimated to 8cm.

The speed of the cable when the motor is activated is :

$$V = \frac{L_{pulled\ per\ rotation}}{T_{rotation}} = \frac{\pi * 5}{\frac{60}{RPM}}$$

with RPM the rotation speed of the motor.

III.2.2. Vacuum strength

The following part will try to estimate the strength of the vacuum, that keeps the suction cups in place during the training. The pressures in action are shown on the **figure III.8**.

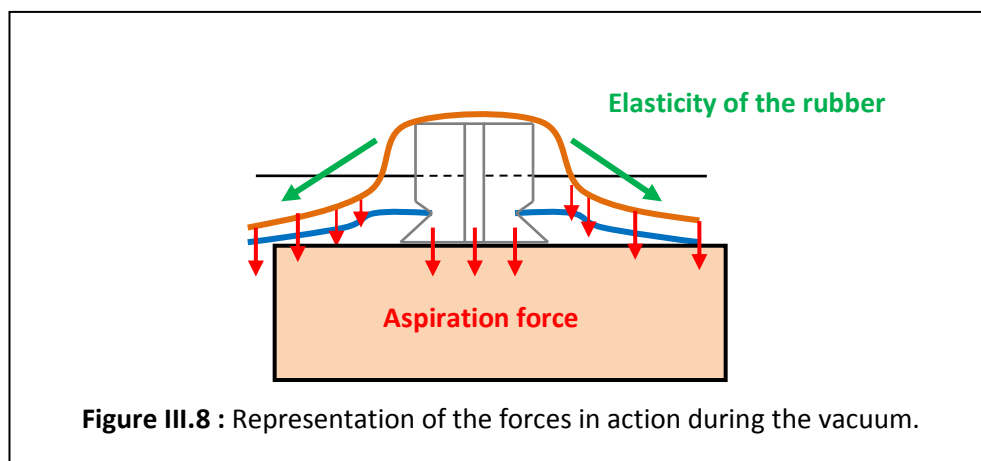

At first, the aspiration sticks the cup to the hand, and then, the outer layer clads over the whole hand and keeps the suction cup in place. The theoretical calculation of aspiration on the cup only would be easy, as we know the aspiration negative pressure of the pump and the surface of the cup. The problem is that the outer layer of the glove covers the top end of the suction cup, and it is the whole surface of the outer glove around the suction cup that pushes it on the hand and this surface is hard to determine, considering that there is probably a variation of pressure on this surface (in orange in **fig. III.8**). Plus, the rubber is deformed around the cup, which induces an elastic strength also holding the cup on the

skin. We won't try to solve further this theoretically, and we will experiment the strength of the vacuum once the prototype is functional.

III.2.3. Simplified mechanical model of the glove

The mechanical forces occurring in the glove during the vacuum and the training exercise are shown in **fig.III.9 and 10**. suction force are not taken in consideration, so the focus could be made on the different forces applied on the cable.

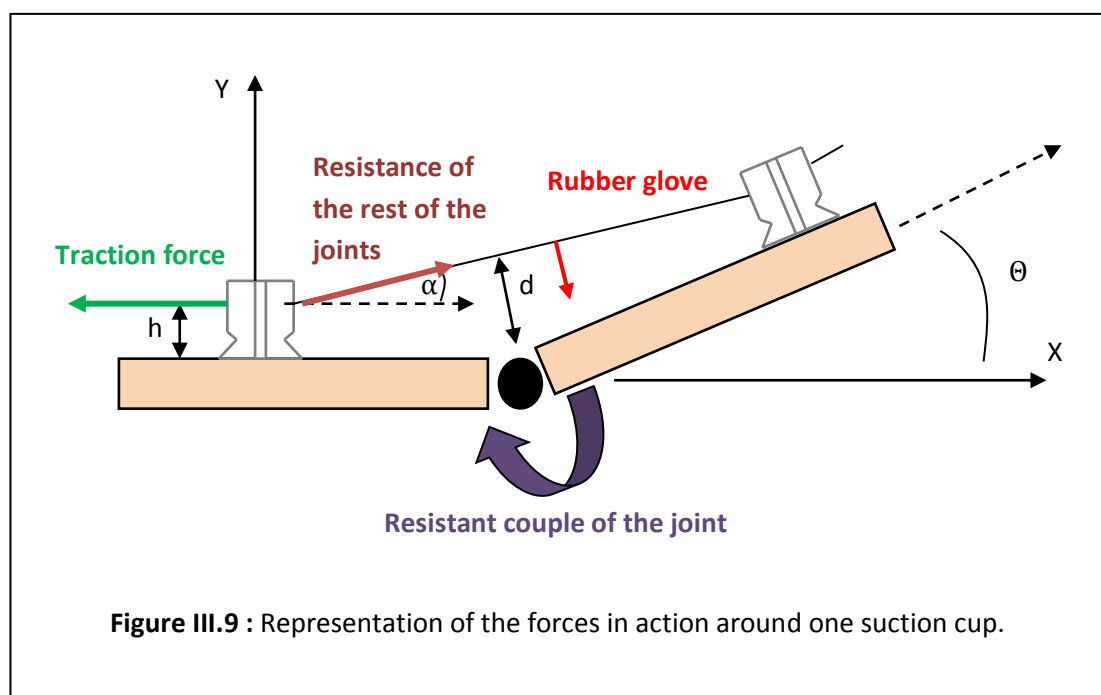

The **figure III.9** represent the forces applied to any of the suction cup, the axis of the phalange of the suction cup was just put at the horizontal. At each joint, the traction force generated by the motor must be stronger than the force induced by every joint of the hand, that implies the natural fluid resistance to movement, which differs depending on the joint of the finger, plus the eventual stiffness induced by the lack of activity of a patient's hand in the acute post-stroke phase. These resistant forces add to take place in the direction of the cable after the suction cup, represented to be angled of α° .

Friction force was almost introduced in the model, of the cup on the cable due to the movement of the cable in the suction cup, but in the palm, the plastic tubing probably avoids the friction, and due to the nylon-rubber and nylon-PVS interfaces, the friction is most likely negligible.

The glove also presses against the tubing and the cable, especially during the last phase of the flexion, when the angles Θ and α are particularly important.

fig.III.9 allows to deduce that the traction force generated by the motor takes the most of the resistant forces by taking the X-component, while the Y-component is absorbed by the suction cup aspiration.

It is a complicated mechanical model, especially with the constant movement of α and Θ , and an estimation of average resistant torque in the joints seems really complex. Once again, after trying to put the theoretical bases of the problem, the equation solving has been abandoned and the project will most likely be based on experimental data. The study will be carried as most macroscopic robotic projects, by over sizing the characteristics of the actuation, enough to be sure to carry out the desired movements.

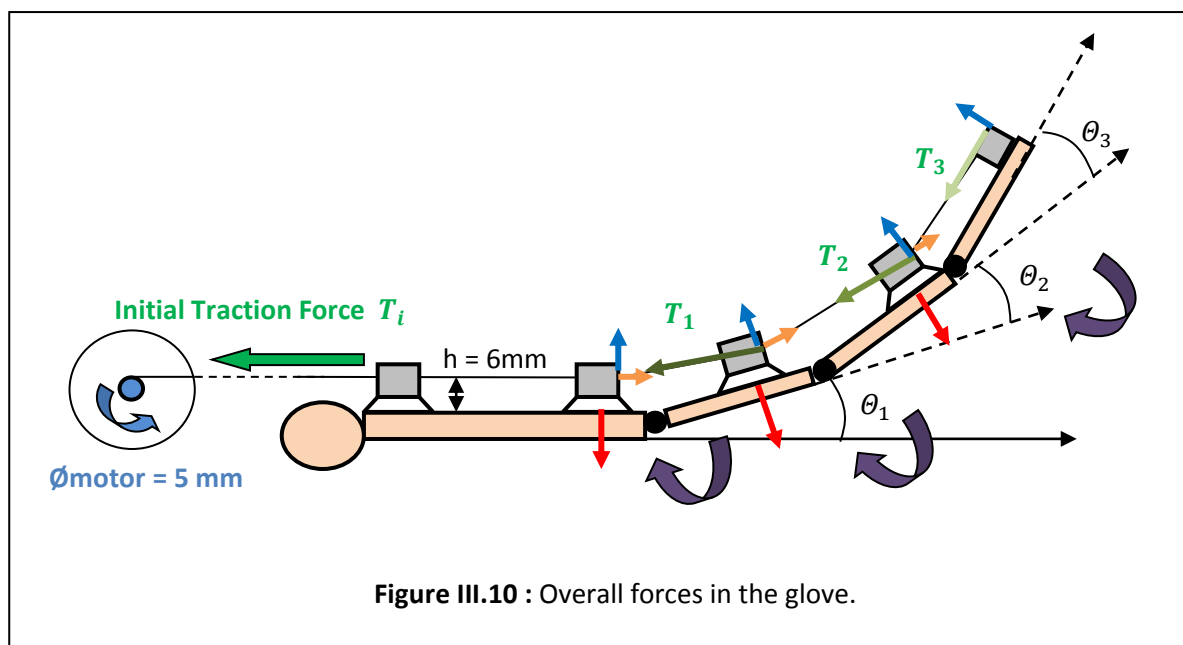

III.3 - Actuation of the glove

Now that the hand-robot interface is designed, the motors designated to operate the cables can be chosen. Their characteristics will then be used to complete a little the mechanical model, and design a structure to integrate them to the Rehabilitation Glove.

III.3.1. Choice of the motors

To achieve the standard fingers flexion exercise, the actuation system of the Rehabilitation Glove must be able to pull the strings to flex the fingers, and to hold the resistant torque of the fingers to keep them flexed for a few seconds. The simplest solution is to use DC motors to actuate the cables. Their control do not allow a lot of different actions, compared to a servo-motor or step-by-step motor based actuation interface, but in terms of functionality, their features correspond to the needs exposed above.

They can be controlled to rotate in two different directions, put them in a magnetic break position, allowing them to hold a load, or leave them in free-wheel. These different modes of the motors are decided by the sense of alimentation of the motors, detailed in the **figure III.11**.

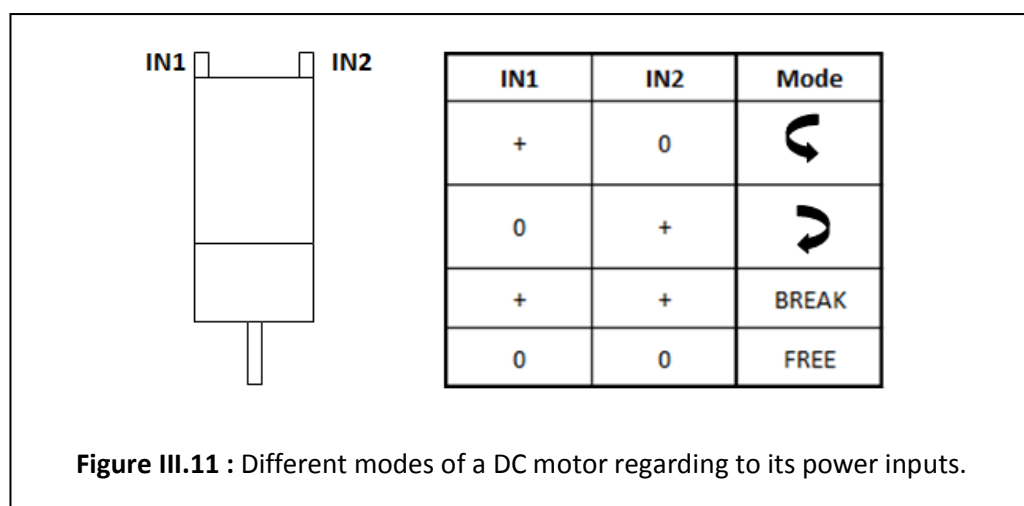

The time of rotation of the DC motors is easily controlled, which is less precise in terms of positioning than an angular position control, but the length of string to be pulled by the motors is not the same for every patient, depending on the range of motion they can reach. Plus for small speed applications like this one, DC motors are very fast to react when they are powered or shut down.

DC motors are a common choice for small robotics applications, and there is a lot of choices for compact little DC motors. The goal of the rehabilitation exercises is not to execute a movement as fast as possible, on the contrary it can create spastic responses in the affected limb or harm the patient, without making him progress in the rehabilitation treatment. Thus, a small brushless motor with very low torque and very high speed wouldn't fit the needs. Even if establishing a precise estimation of the motor torque needed was difficult, and as long the speed of the movement is not too high, the best solution is to choose a motor that will obviously be able to provide enough torque.

A small DC motor with a rotation speed of 23 Rotations Per Minute (RPM) and a theoretical torque of 103 oz.in, has been chosen as actuator for the cables. Its torque is roughly equivalent to 0,72 N.m, and the speed at which the hand will flex and the traction force developed can now be calculated. The full specs sheet of the motor is available in the

APPENDIX II.

Speed of flexion :

$$V = \frac{L_{pulled}}{T_{rot}} = \frac{\pi * 8}{\frac{60}{23}} = 10mm.s^{-1}$$

Combined with the 8cm result for the length of cable to be pulled, it results in an 8 seconds movement, which is quite slow.

Cable Traction equation :

The torque of the motor is 0,72N.m, with an axis of 5mm, so the basic traction force developed should roughly be :

$$T_i = \frac{0,72}{5} * 1000 = 144N$$

It seems like the choice of the motors could have been oriented on slightly weaker, but faster motors.

III.3.2. Architecture of the actuation

All the elements outside of the glove now need a support : the motors, the vacuum pump, the control interface and the batteries for the system, must be fixed in a way that will keep the device compact and easily wearable. The design was oriented on a small platform with a shape adapted to the patient's forearm , which will be attached with straps or a contention sleeve. The **figure III.12** shows schematic drawings of the architecture of the actuation system, integrated in the Rehabilitation Glove.

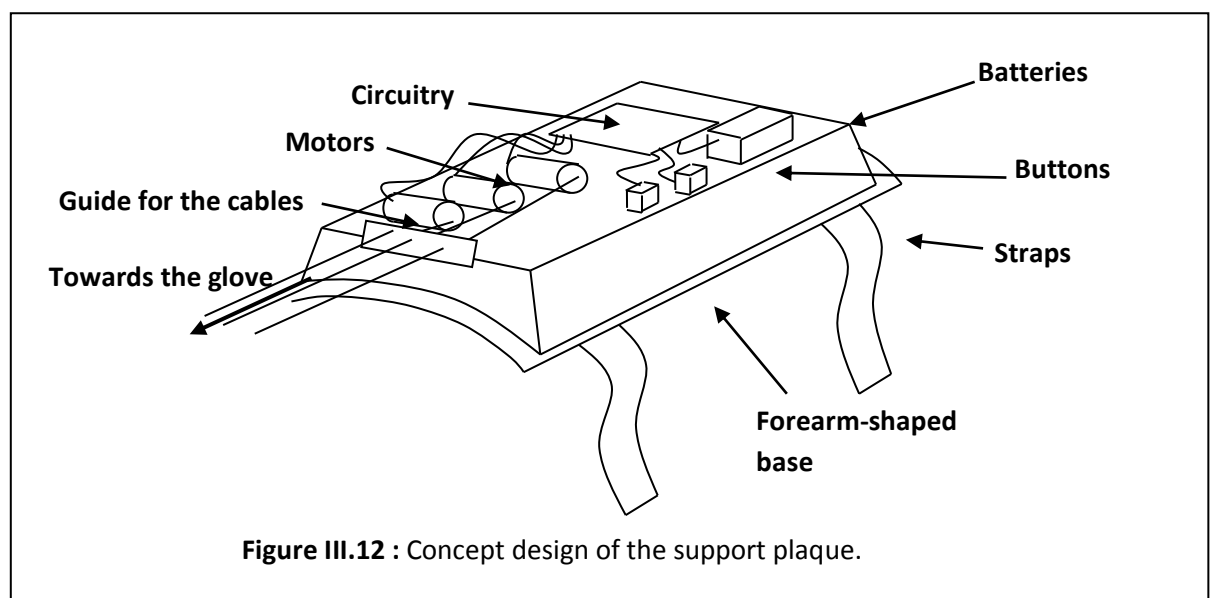

This support plaque would be covered afterwards by a 3D-printed cover, to hide the circuitry and the motors, only leaving an access to the batteries and the controls of the system.

The vacuum pump being slightly bigger and producing a lot of vibrations when put under tension, will be hold in a strap, around the patient's hip, reaching the glove through a rubber tube 70-80 cm long. This rubber tube would eventually be guided by rings on the side of the support plaque.

III.4 - The construction

Now that the conceptual designs of the Rehabilitation Glove have been exposed, this part will detail the step-by-step construction of the prototype, with intermediary remarks and small tests made during the construction.

III.4.1. Realisation of the glove

The realisation of the inner glove is not difficult, but requires care and precision, because the rubber glove is easy to damage and everything has to be strongly in place because everything is going to be covered by the outer glove. Each different steps will have a picture to show the advance of the prototype in **figure III.13**.

Step a. First we mark the glove at the different positions decided for the suction cups (in **part III.1**). A 4-5mm incision must then be made in the glove at all those points.

Step b. All the suction cups are passed through the pre-made holes, and glued in position. After waiting 12-24hours, a new layer of glue is applied to make sure the glove-suction cup interface is sealed.

Step c. The cables are fixed to plastic rings that will be glued to the tip of each finger.

Step d. Every suction cup is pierced with a needle. The small plastic tubing is then put in place through the suction cups in the palm of the hand, and finally a sewing needle is used to pass the cable through the fingers' suction cups, and pass the cable through the plastic tubing.

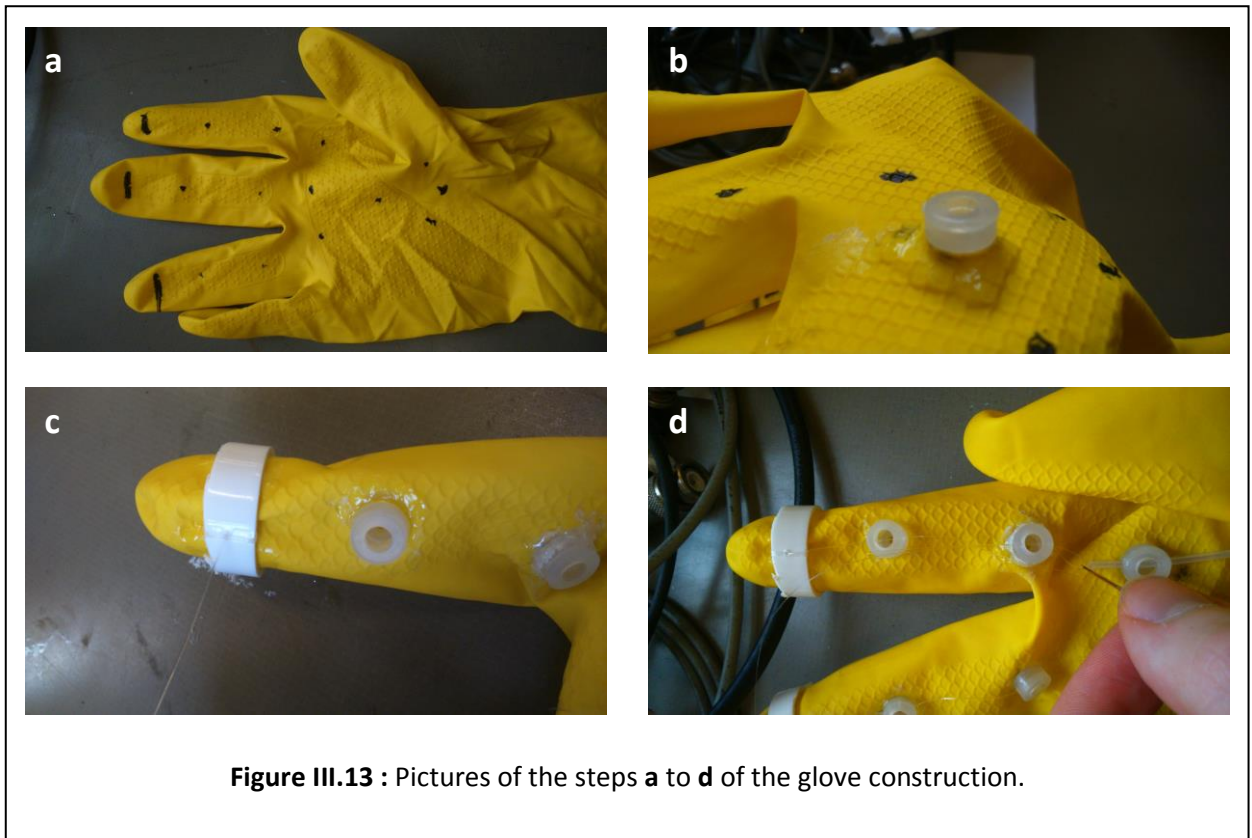

Figure III.13 : Pictures of the steps **a** to **d** of the glove construction.

The inner layer is ready, and tests can now be performed to see how the cables pass through the cups, make sure the cups are well in place, as well as the top plastic ring. The construction of the outer layer also starts, with step-by-step pictures in **fig.III.14**.

Step f. Make a 8-9mm hole in the outer glove, and place then carefully glue the small plastic piece that will serve to attach the vacuum tube.

Step g. Small holes are made to let the tubing from the inner layer pass through. The inner layer is then fitted inside the outer glove and as usual the tubes are glued to the glove to keep the sealing effective.

Step h. Cut the outer glove at a proper length and seal the two gloves together with sealing, air-proof, tape (non-adhesive). The tape allows to unseal the two gloves if desired, to work on eventual issues on the inner layer, like a detached suction cup, without destroying the gloves.

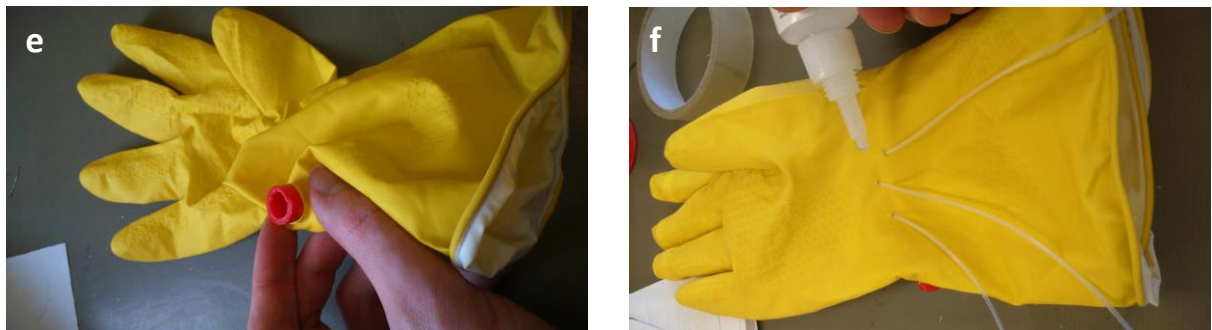
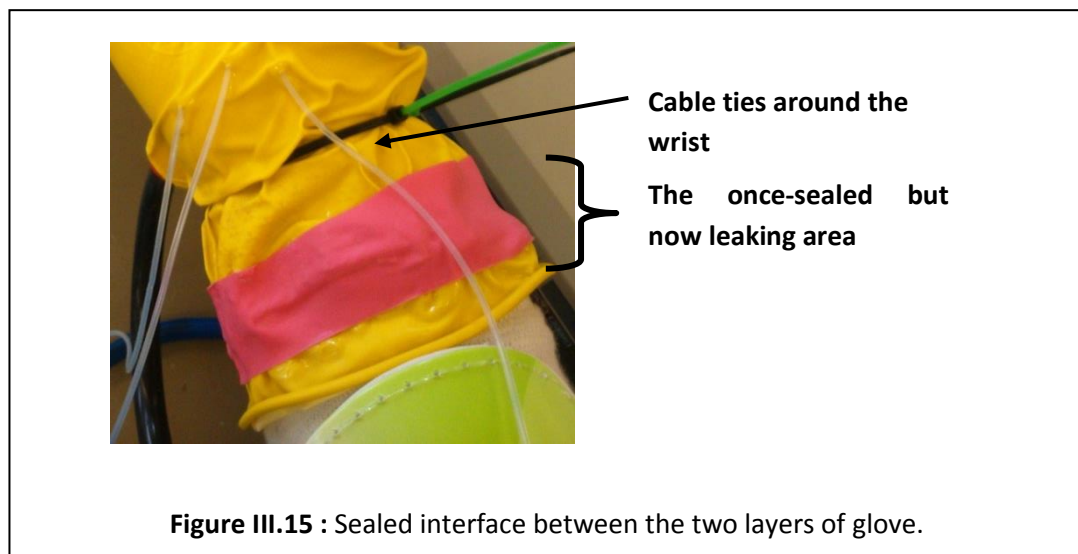

Figure III.14 : Pictures of steps **f** and **g** of the glove construction.

Unfortunately, after a test of the sealing between the two gloves after the construction, the glove/tape area got damaged during transportation of the prototype. The sealing of two rubber flexible surface is very hard, as soon as one small part of the glove has detached from the tape/area glued, the whole surface folds on itself and the situation keeps getting worse and worse.

Efforts were made to rectify the holes in the sealing with glue, and then another layer of rubber, glued on the two glove layers, but the leak could not be repaired efficiently. In the

end, to continue experimenting on the prototype, plastic cable ties were used, as shown in **figure III.15**, which was working, but quite uncomfortable.



III.4.2. Realisation of the motor support

The construction of the support plaque then started, but was unfortunately delayed by a health incident of the supervisor of the mechanical workshop of the department.

A tibia protection, originally destined to protect football players, was purchased, and sewed to an elbow power contention sleeve, to don it easily someone's forearm, as shown in **figure III.16**., along with the vacuum glove, not yet attached to the motors.

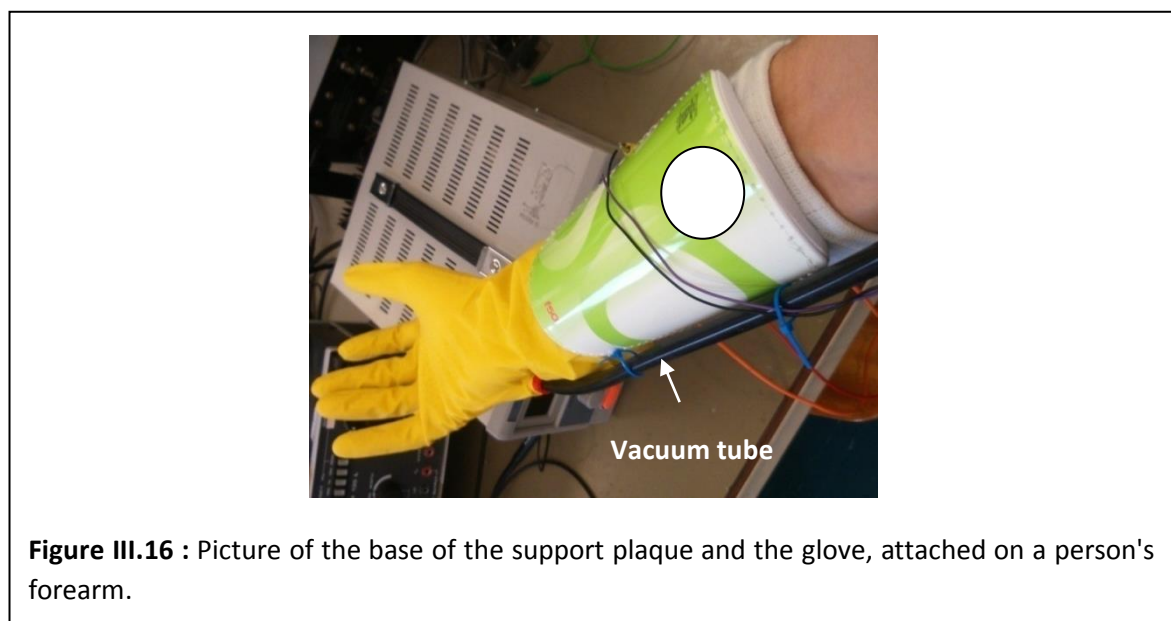

Like it was explained above, due to an incident, the wooden piece that was meant to be fixed to the support base couldn't be realised in time and from the flat support plaque the motors would have been attached to. A detailed concept design of the imagined part is shown in **figure III.17**.

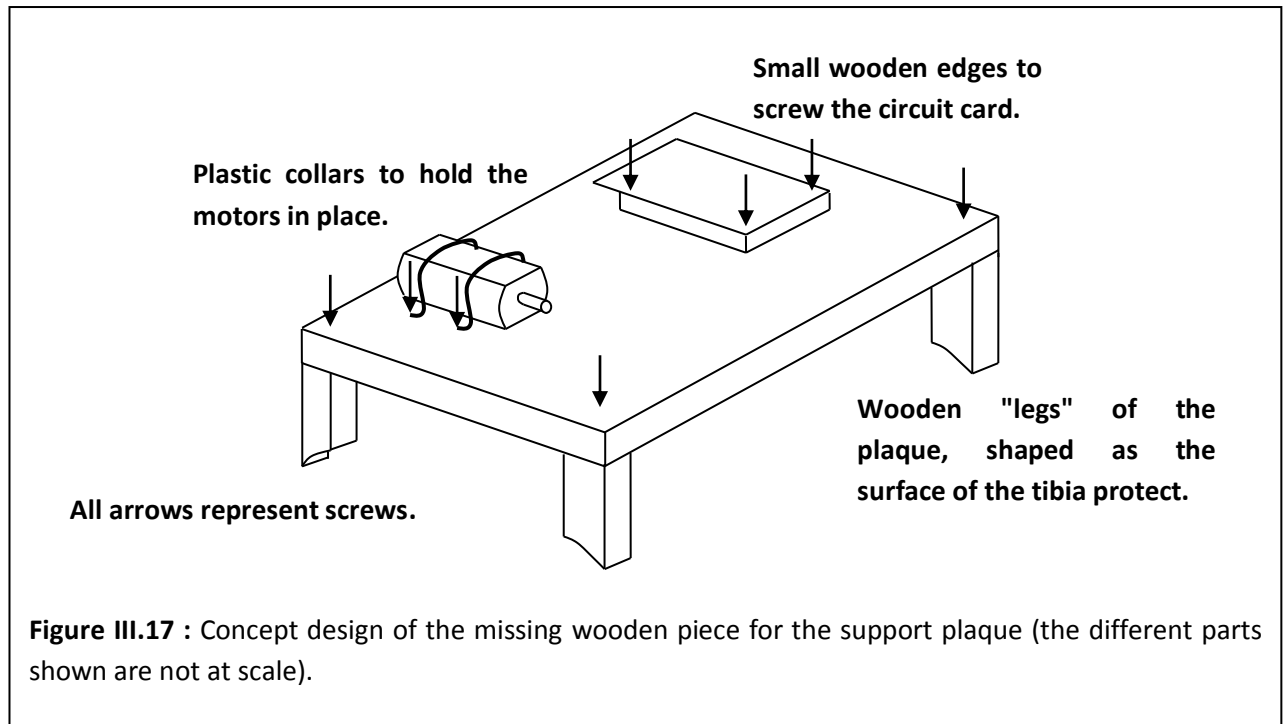

II.4.3. Criticism of methods and remarks

Vacuum Tubing interface

The vacuum test proved the sealing methods quite satisfying, but the connection between the glove and the pump tubing was improvised and was directly oriented towards the inner layer, which made necessary to hold the vacuum tube in a precise position from time to time. The connection to the vacuum tube would probably be better with a proper plastic hose fitting, like the one showed in **figure III.18**, but this was not highlighted during the

design phase, and for timing reasons, it was not possible obtain one and replace the former part used during the construction phase of the project.



Glue

Two different methods were tried to glue the suction cups, one time with plastic-welding epoxy paste, which appeared not to be strong enough to hold the suction cups in place, and standard liquid strong glue, which worked quite well, but still was not an optimal way of fixing and sealing every piece of the prototype. For a further development of the Rehabilitation, a better plastic-welding method should be researched and considered.

Sealing between the two gloves

A good future objective in this project would be to design a properly sealed, adjustable/removable interface between the two gloves' flexible layers.

It is easy to focus on functional parts of the design and forget such important points while in the prototyping phase of the project, but it the hope of the researcher that the mistakes once made will help the design of the glove to progress even further in the future.

IV - Electronic Interface and Control of the Rehabilitation Glove

IV.1 - Specifications and Control Interface

This short-time project aims to work on the control interface of the device so that the prototype is made for demonstrating purposes, but can also be improved in the future with possible new training exercises, and the ability to add new motors and functionalities. For a matter of time and simplicity, the control interface we want to develop now is a button-press control as simple as possible for the patient, but the design of the circuitry and control interface should be made to facilitate further work and addition of new components.

IV.1.1. Specifications of the device The objectives of the Rehabilitation Glove are to allow a patient to execute basic active or passive hand and fingers exercises, with the most simple user interface as possible. For the prototype of the glove, because of time limits, we focused on the single exercise of hand flexion, but the whole design of the control interface is made so that it can be applied to a wider range of exercise.

The hand flexion exercise consist in activating the DC motors to pull the strings and thus assist the fingers flexion, then when the desired level of flexion is reached, use the magnetic break of the motors to help the patient hold his fingers flexed for a pre-determined time (set to 3 seconds on the prototype), and finally put the motors in free-wheel to release the fingers from the motors' action and let the hand go back to a relaxed position.

Three different features of the DC motors described in **part III.3.1** are used by the hand flexion exercise and switching between them implies to be able to switch between three different sense of alimentation of the motors (detailed earlier in **figure III.3.1**). Plus, an exercise which would emphasise the fine control of the fingers by flexing them one by one could be imagined, needing the same series of activation of the dc motors, but one by one, implying a coordination that cannot be reasonably asked to a patient.

The ideal scenario would be for the patient to only have to interact with one or two buttons, which would be the inputs of a program that would command the series of actions of the motors. The control interface will thus be based on a programmable print circuit.

IV.1.2. Control interface and choice of components

L293D motor controller chip

The most common and simplest way to operate DC motors is the use of H-bridges, where small current inputs are used to switch the state of transistors ruling the direction of the power supply of the motors, enabling to switch between the different modes of DC motors if we control those current inputs. This function will be achieved by three **L293D** common motor controller chips, which contain two built in H-bridges each, to control our motors. Each L293D is able to control two different motors. The **figure IV.1** shows how the L293D must be integrated to a circuit and the **table IV.1** sums up the different output modes of the motor in relation with the current inputs of the chip.

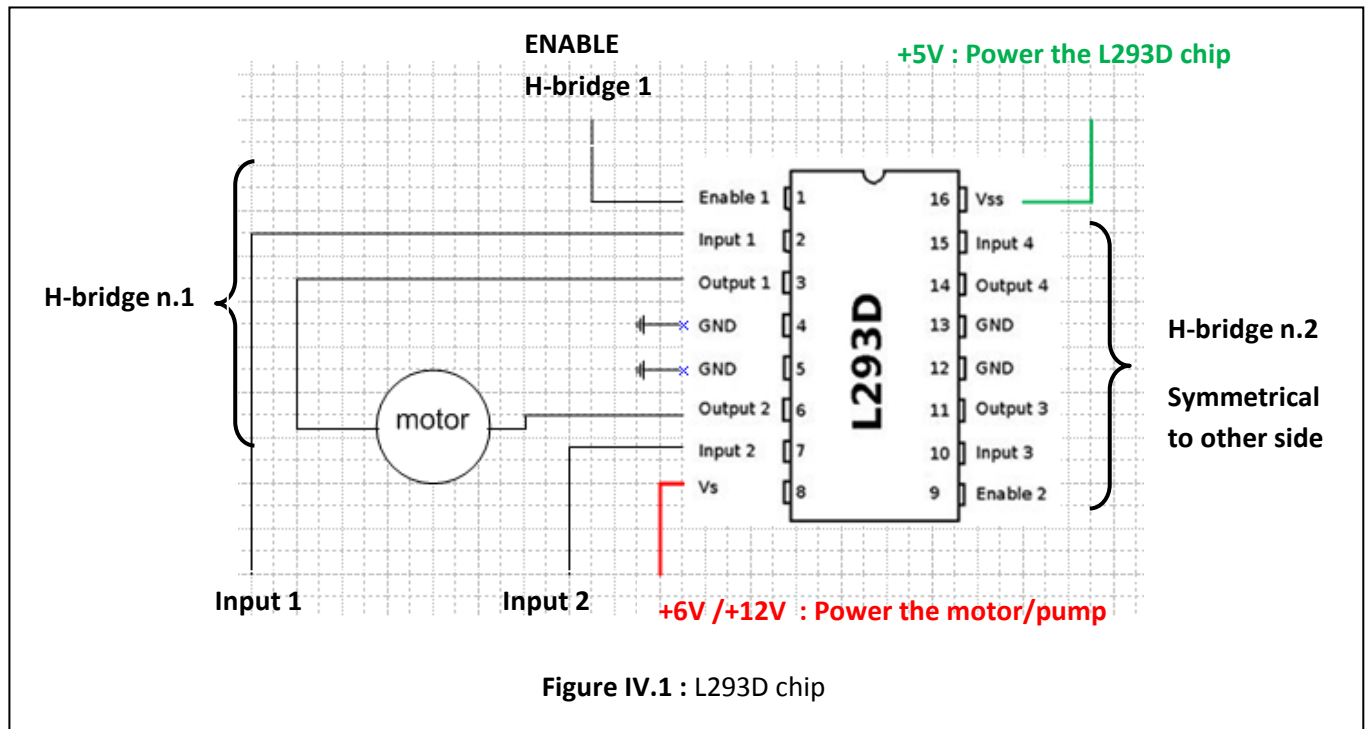

- The ENABLE input is like an ON/OFF switch, it must be put to a high state to allow the corresponding H-bridge to work.
- The L293D use a regulated 5V power supply to work, connected at the Vss pin.
- The Vs pin is the power supply for the motor connected to all outputs. That means two motors can be used with only one L293D chip, but they need to share the same power supply. Thus, the pump (12V) must be isolated on its own L293D and the motors plugged to two other chips.
- The input/output transfer function is straight forward, if the input no.X is put at a high state, the output no.X will be powered with the voltage provided at Vs. Thus, the same logical table as in **part III.2** is obtained :



IN1	OUT1	IN2	OUT2	Mode
HIGH	HIGH	LOW	LOW	
LOW	LOW	HIGH	HIGH	
HIGH	HIGH	HIGH	HIGH	BREAK
LOW	LOW	LOW	LOW	FREE

Table IV.1 : Logic Table of the L293 and corresponding motor mode.

Polarities have to be clearly marked on the motors to show which is n.1 input, so that they are easy to connect to the L293D without mistake, for them to share a common rotation direction.

Arduino nano microcontroller

Amongst the wide range of microcontrollers, from the PIC category to all the Texas Instruments chips, an Arduino™ card was chosen, for its simplicity of integration in circuits, the simplicity of programming (C language), and the number of program and circuits tutorials easily available online. It is often on Arduino cards that Electronic Engineering students start learning the basics of programming.

The Arduino Nano model, which is their smallest card seemed the most suitable model. It shares most of the features of the standard model, and can be plugged to the computer with a mini-USB cable, to power the card for the test phase and easily communicate the program made on the computer. The **figure IV.2** is directly taken from the Arduino website and describes the different functions related to the pins of the Arduino.

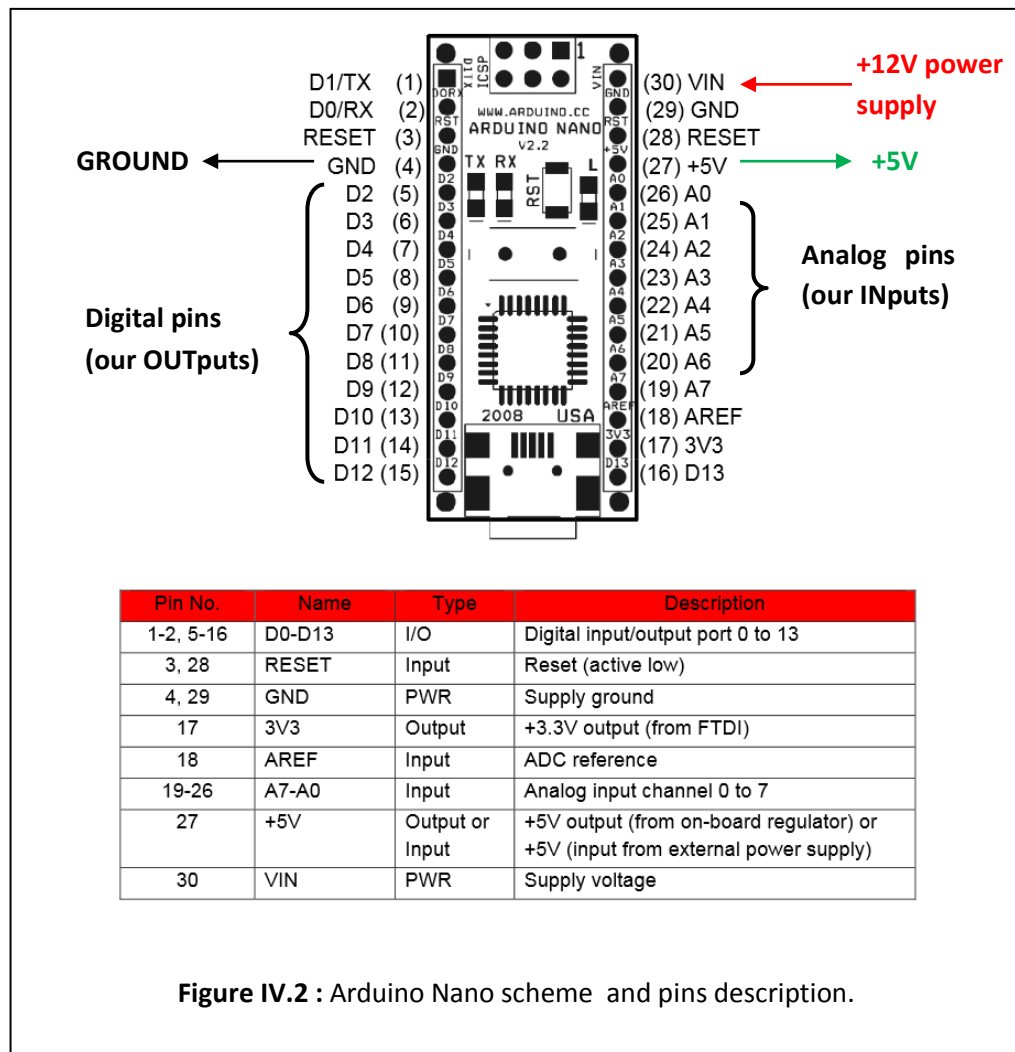

The integration of the Arduino in our electric circuit, as well as the communication between with the L293Ds, will be explained in **part IV.2**. A first draft of the program that will be uploaded to the Arduino can now be written.

IV.1.3 - Objectives and Program first draft

Simply, one ON/OFF button would power the whole system, and immediately activate the Vacuum in the glove. Then, the patient would only have to press a push-to-make button to activate the motors. When the patient or the therapist considers that the hand is flexed enough, the release of the button would make the motors hold the position for an easily

adjustable time, and then the motors would start rotating in the other direction to slowly release the force exerted on the fingers. There the system would need a timer to count the time for which the patient pressed the button, in order to reverse the rotation for the same amount of time and come back to initial position. During all this time, the vacuum would be active.

A few LEDs will be added to the circuit to display different colour codes when the motors are rotating in direction1, direction2, or simply holding the position.

Without bothering yet with the programming language, a first draft of the is shown on **figure IV.3.**

```

SETUP {

    Allocate input and output names to their pin number;

    Define input pins (one analog input) ;
    Define outputs (several digital outputs) ;

    Create boolean values to detect the state of the motor button;

    Create integer time values for the moment the button is pressed and the
    moment the button is freed;

    Create value for the HOLD time of the motors;

    Define the different functions :

        MotorsON()
        MotorsREVERSE()
        MotorsHOLD()
        MotorsOFF()

        PumpON()
        PumpOFF()

    Create a logical function to detect not only the state of the button, but also
    when it is pressed, and when it is freed;

    Enable the L293Ds at maximum power; }

```

```
LOOP {  
    PumpON()  
    Detect the button state;  
  
- if button is pressed, MotorON() and obtain the time = time1  
  
- if button is freed, obtain the time = time2,  
    MotorHOLD for "holdtime" then MotorREVERSE for (time2 - time1)  
  
else, MotorOFF(). }
```

Figure IV.3 : Program draft.

All the L293D inputs must now be allocated to Arduino pins and it is only after finishing the design of the circuit that the final program will be realised.

IV.2 - Circuitry

All the electrical schemes presented in this part will be grouped in the **APPENDIX III**.

IV.2.1. Communication between components

The final output of the circuit is the rotation of the motors, triggered by the L293D, themselves trigger by the Arduino. The mapping of the arduino-L293 interface and the different pins chosen will here be explained. The wiring is shown in the **figure IV.4**.

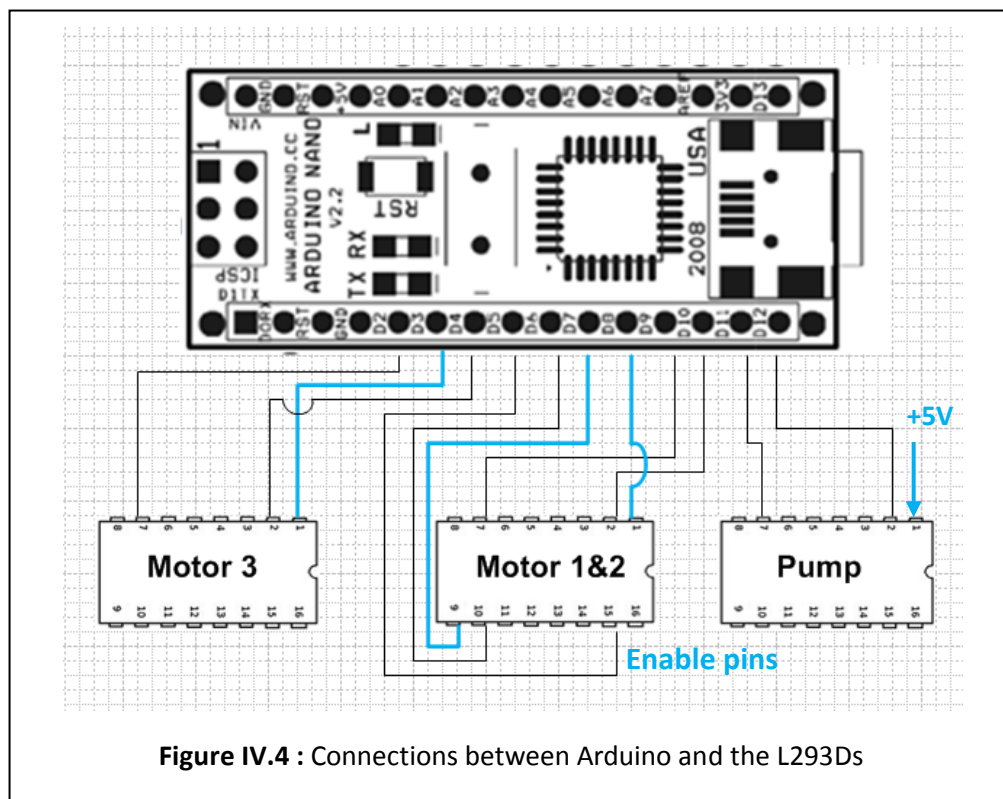

Figure IV.4 : Connections between Arduino and the L293Ds

As explained earlier, to control three or four 6V motors and the pump, 3 L293D chips are needed. For this prototype, it was decided to only actuate three fingers, to use the prototype as a proof of concept more than a functional rehabilitation device. It will still be possible to add a fourth motor on the circuit later.

Then ENABLE of the pump is directly linked to the 5V, because the vacuum has to always be on as soon as the circuit is powered.

The three ENABLE pins corresponding to the motors H-bridges on the L293 are connected to the pins D3, D7 and D8 of the Arduino. These pins are chosen in particular because they are part of the PWM digital pins, we can control the amount of power they deliver instead

of a binary state, which will in turn control the amount of power delivered to the motor and thus its speed.

Then, a digital pin of the Arduino is allocated to each of the 8 L293D inputs (4 motors plus one pump = 4 pairs of input), organising the pins in order to simplify the programming and the wiring of the circuit. Each pair of motor cables must then be connected to their corresponding output on the L293D. This will be shown on the full electric circuit and the tables of inputs/outputs at the end of the part.

IV.2.2. Power supply

Three different voltage are to be supplied in our circuit : +5V for the L293Ds, +6V for the three motors, +12V to power the Arduino and the pump. Conveniently, the Arduino has an integrated 5V output, precisely to allow to power other components (5V is a very common operating voltage for electronic parts). Consequently, the L293Ds are directly powered by the Arduino.

But our goal is for the Rehabilitation Glove to be wearable, so the number of batteries carried by the patient has to be as small as possible. To be able to power the circuit with only one source of power of +12V, a small regulation system is added to transform it into 6V supply for the motors. The component used there is a LM317T regulator, shown below on **figure IV.5**. It uses a simple resistor bridge to adjust the output voltage.

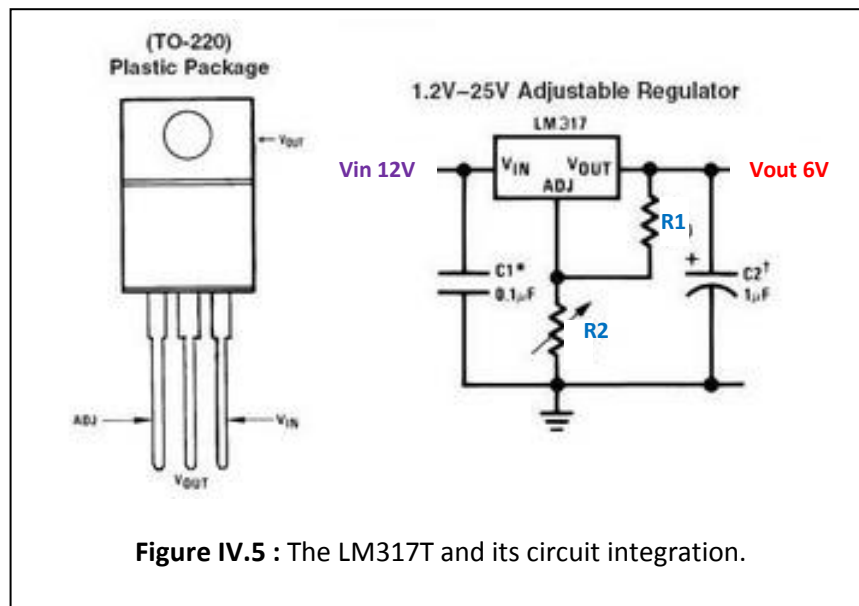

The adjust pin delivers 1.25V, it is recommended to have a resistor R1 with a value close to 240Ω, and the R2 resistor value is chosen with the equation given by the resistor bridge :

$$V_{out} = 1.25 * (1 + R2/R1)$$

which gives us a R2 value approximately 4 times bigger than R1 to get a 6V output, a resistor of 1kΩ was thus chosen.

This way, only one 12V battery is needed to power the whole circuit. The battery would have to have a huge capacity, because of all the components draining its current (theoretically around 700mA when the motors are on). But the technology of batteries evolved a lot in the past years, and a lot of different solutions exist. The prototype was powered by an external power generator during the test phase, but the circuit is ready to accept a battery input.

The overall power supply circuit is shown on **figure IV.6**.

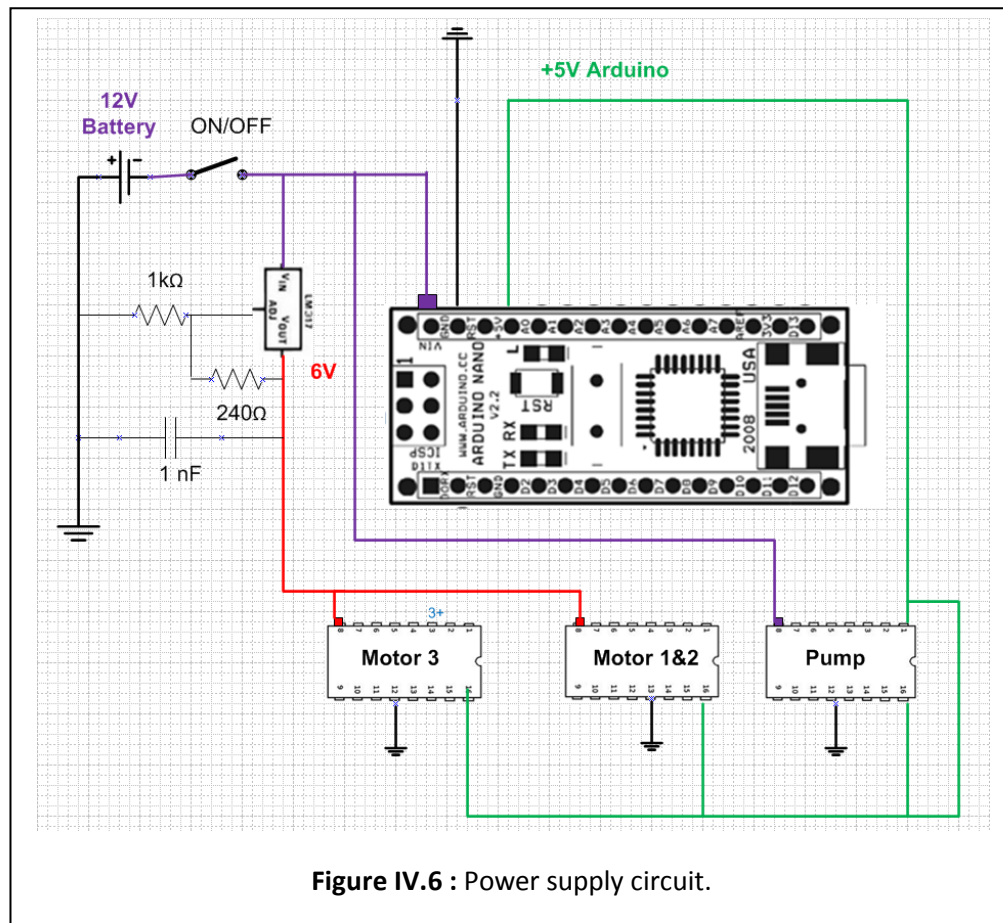

Figure IV.6 : Power supply circuit.

IV.2.3. Other components of the circuit

To complete our circuit, the last step is to integrate the different buttons for the control, and also a few LEDs to visually indicate the state of the motors and of the vacuum pump.

The **figure IV.7** show the integration of the push to make button to the Arduino.

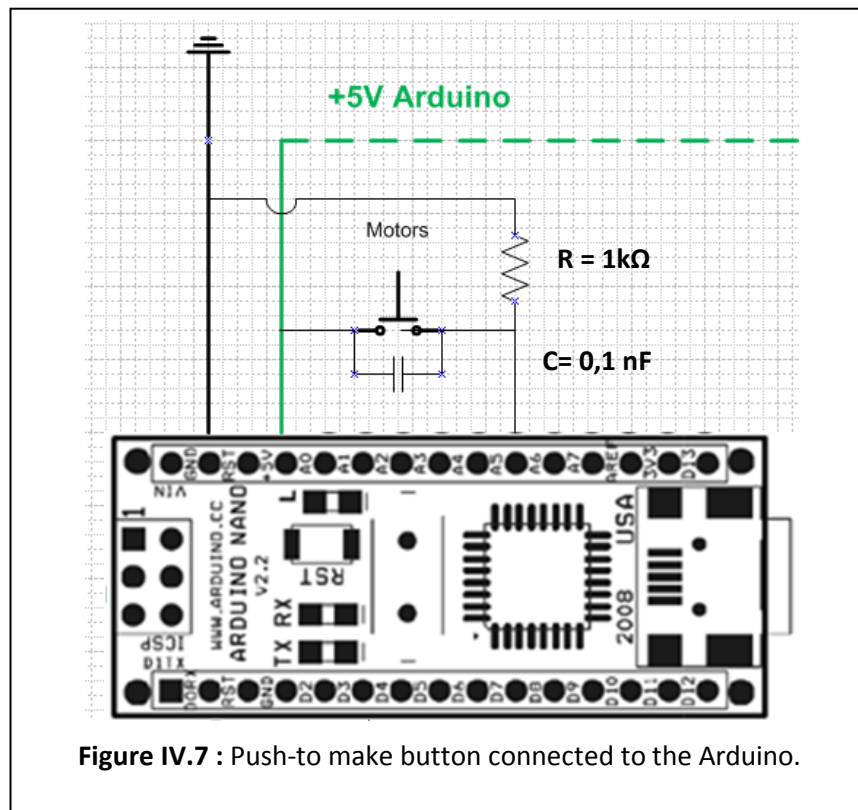
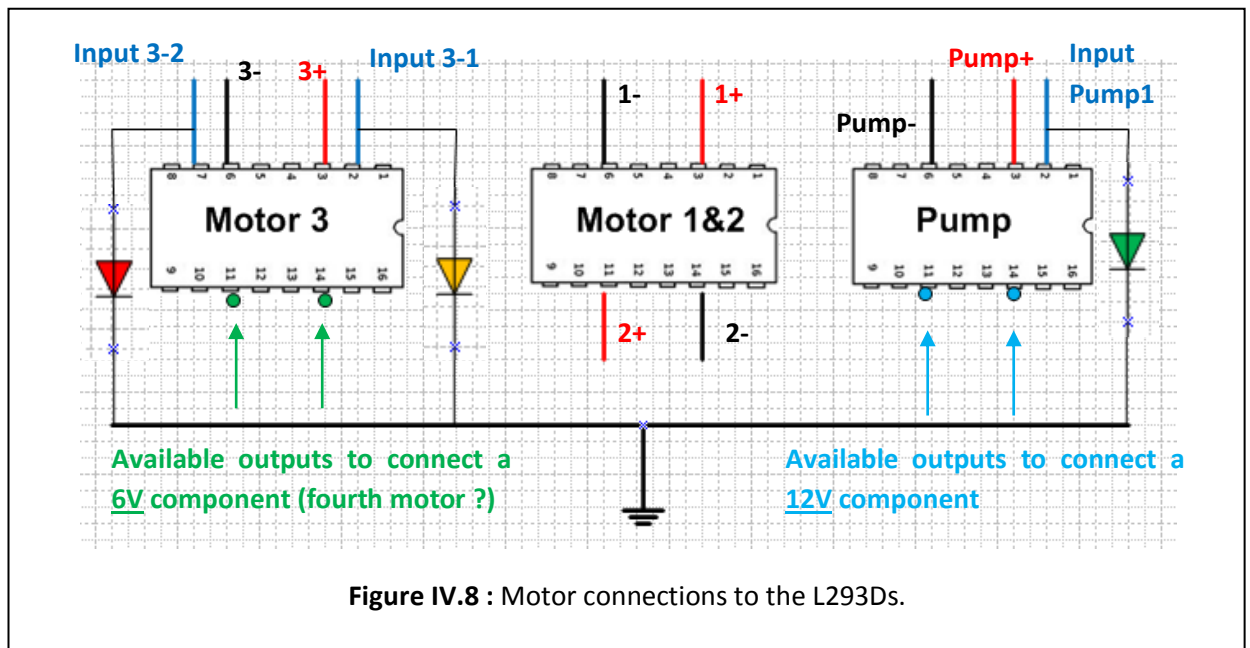

Figure IV.7 : Push-to make button connected to the Arduino.

The button is connected to one analog pin of the Arduino, A2 was arbitrarily chosen. The other end of the button is connected to the 5V output of the Arduino. The A2 input is connected to the ground via a 1kΩ resistor, and when the button is pressed, A2 connects to the 5V, getting a HIGH state. The capacitor is a anti-bounce capacitor, it is a very common solution to absorb noise from fast changes of the pushbutton state. The values for C and R are the one we used in the circuit, but those components don't need a precise value, it is just an approximate order of magnitude.

The connection of the motors to the L293Ds is pretty straightforward, but it will probably not figure on the final circuit scheme for a better readability of the circuit, so the connections were displayed here on **figure IV.8**. The LEDs were also integrated to this scheme to explicit their functions.



About the LEDs, if the ump is on, a current will be send in the input Pump1, which will also light the green LED, and this green LED will be on as long as the circuit sends power to the pump. For the ones plugged on inputs 3-1 and 3-2, they show the rotation direction of the motors : if the rotation is on, the input 3-1 will be powered, and the yellow LED will light, the same way, if the motor is on hold, both LEDs will light, and if the rotation is on reverse direction, only the red LED will light.

Now that all the connections are made in the circuit, the final program can be written.

IV.3. Programming the Arduino

This part will not be a detailed approach of C language programming, but a review of three key points of the program that could need some further explanations. The full program is available in the **APPENDIX IV**.

IV.3.1. Detection of the analog button state

This part of the program is shown in **figure IV.9.**, and will then be detailed.

```
boolean MotorState = Free;

boolean ReadMotorState(){
  boolean result = Free;

  if(analogRead(MotorButton)> 512)
  { result = Pressed;}

  return result;
}

byte ReadMotorEvent(){

  byte Event;
  boolean NewState = ReadMotorState();

  if(NewState == MotorState)
    Event = Motor_No_Event;

  if ((NewState == Pressed && MotorState == Free)|
    Event = Motor_Button_Pressed;

  if(NewState == Free && MotorState == Pressed)
    Event = Motor_Button_Free;

  MotorState = NewState;
  return Event;
}
```

Figure IV.9 : Button event part of the program.

The analog inputs of the Arduino don't detect a binary LOW or HIGH state of current, they detect a 10-bit value of the voltage input. It means that a 0 to 5 volts difference is translated into numerical values from 0 to 1023. A middle value is thus set at 512, and if the

input detected exceeds this value, the button will be considered "pressed" by the program, which we defined as being a HIGH input state.

Then, it is a standard iteration method to compare the actual state of the button (Pressed or Free) to its former state. Depending on the conditions met, the button event will then be considered as no new event, button just pressed, or button just freed, which will allow the triggering of the motor hold and then turn back to initial position, after the patient stopped pressing the button.

IV.3.2. Button timer

In the loop of our program, a timer will automatically detect the time the motors have been activated in on direction, to be able to tell the motors to turn in the other direction for the same amount of time, and take back their initial position. It is shown in **figure IV.9**.

```
if(Event == Motor_Button_Pressed) {
    timepress = millis();
    MotorON();
}

//when we stop pressing the button

if(Event == Motor_Button_Free) {
    timefree=millis();
    MotorHOLD();
    delay(3000);
    MotorMINUS();
    delay(timefree-timepress);
    timepress = 0;
    timefree=0;
    MotorOFF();
}
}
```

Figure IV.10 : Timer of motor activation.

In the Arduino language, the function *millis()* returns the actual time of the system in milliseconds. By setting a timer *time1* when the button is pressed, and a timer *time2* when the button is freed, the motors can be asked to turn in the reverse direction for $(time2-time1)$ milliseconds. The timers must then be reset, in case of problem in the loop execution order.

IV.3.3. PWM outputs

It has been said in **part IV.2.** that the ENABLE inputs of the L293Ds chips will be connected to the digital Pulse Width Modulation outputs (PWM). It means that instead of communicating the full command the L293Ds, it is possible to send series of impulsions, which frequency is bound between 0 and 255 Hz. The motors won't be able to react to very fast changes of command and the output will approximately be determine by an average of the incoming impulsion series. The **figure IV.11** shows how the PWM works, and the **figure IV.12** show the line associated in the program.

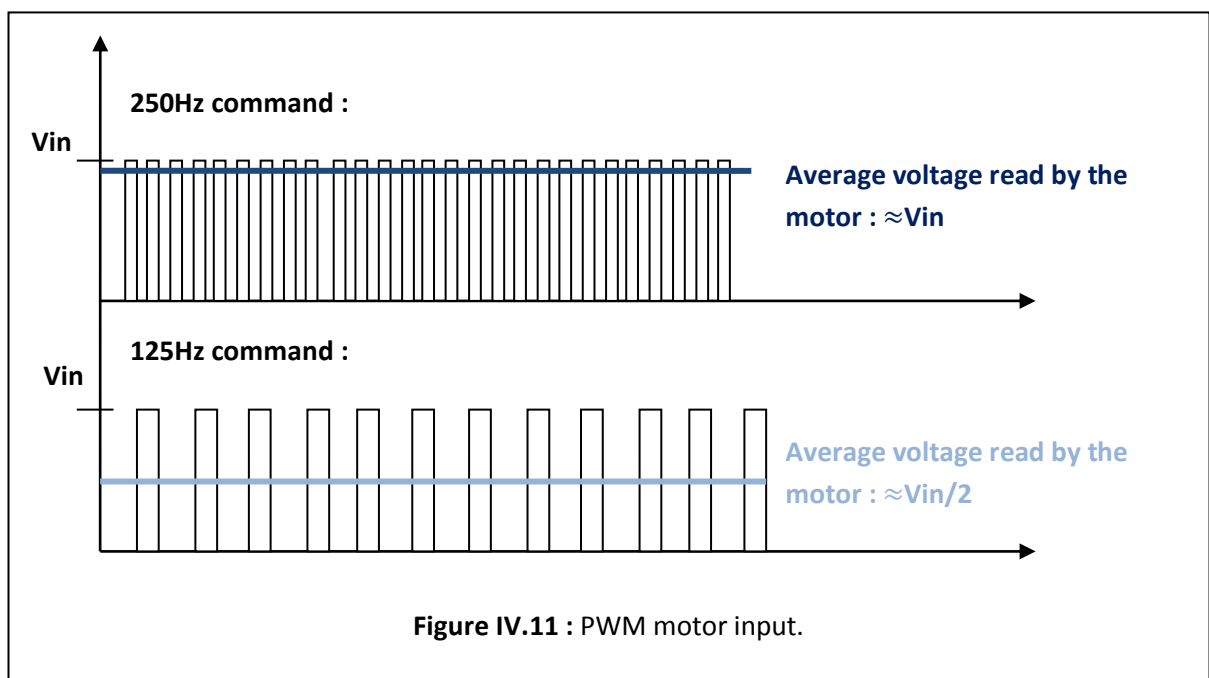

```

analogWrite (EN1, 250);
analogWrite (EN2, 250);
analogWrite (EN3, 250);

```

Figure IV.12 : PWM program.

The program is then checked for syntax errors and uploaded to the Arduino board via the mini-USB cable. The realisation of the electrical circuit can begin.

IV.4 - Circuit Realisation

IV.4.1 Full electrical circuit

The full circuit is shown on **figure IV.13**. and is also available in the **APPENDIX III**.

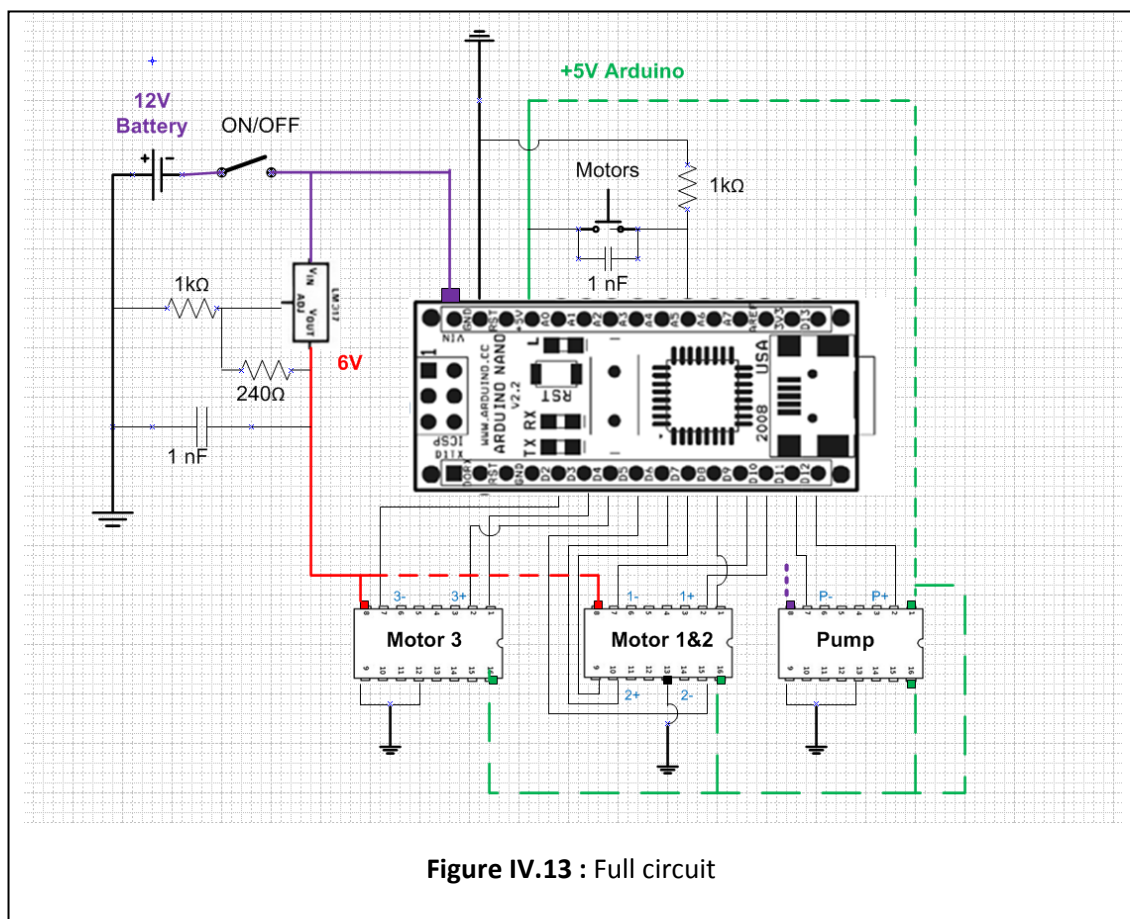

Figure IV.13 : Full circuit

IV.4.2. Test phase

The testing starts with all individual components, especially the motors, and also to check the polarity of every switch and capacitor. Then the components are placed on a breadboard and the circuit is constructed bit by bit, which allows to test the different voltages in the circuit for example, using a little probe and an oscilloscope, as shown in **figure IV.14**.

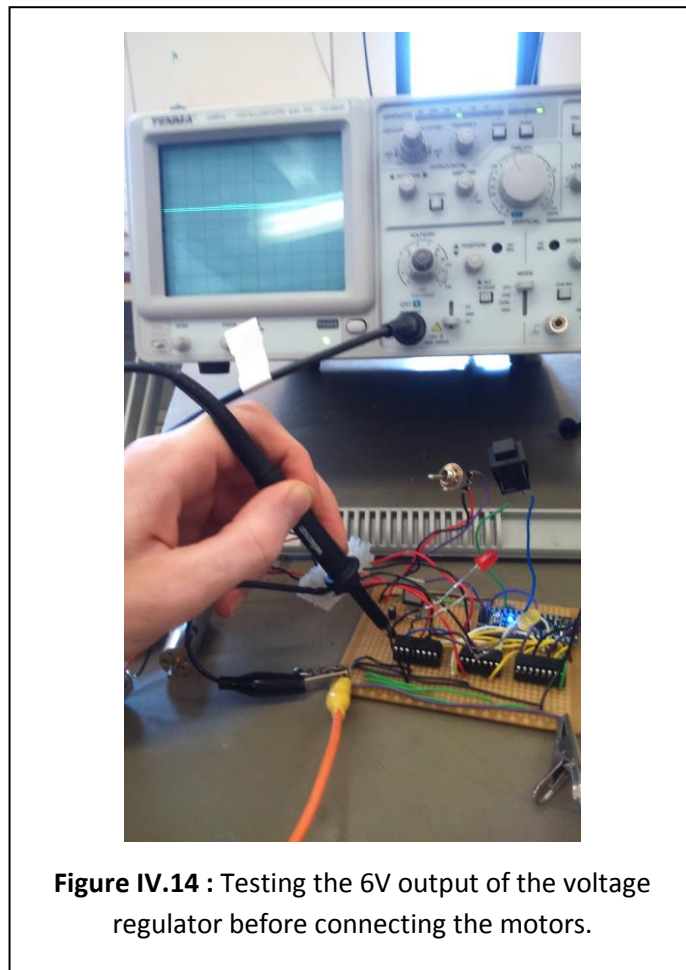

Figure IV.14 : Testing the 6V output of the voltage regulator before connecting the motors.

The full circuit realised on breadboard is shown in **figure IV.14**.

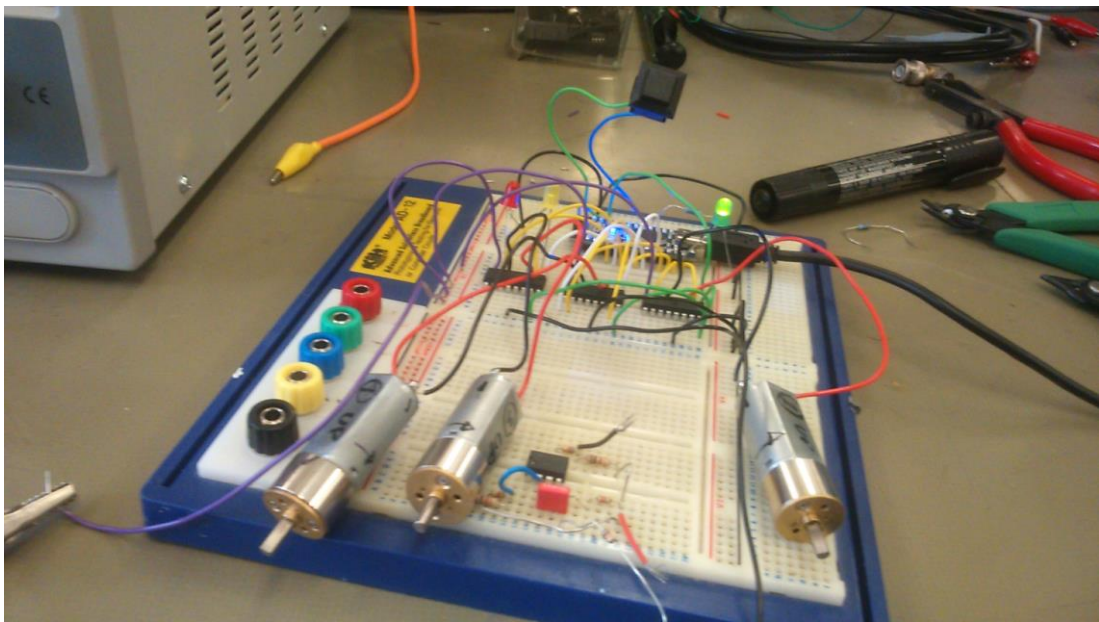

Figure IV.15 : Full circuit being tested on the breadboard, for noise reasons, the pump was not plugged, but the illuminated green LED shows the outputs are correct.

The program showed in the **part IV.3**. is the final version, during the design phase, it has been tested and modified several times already, especially for the analog button detection part.

IV.4.3. Circuit soldering

When the results shown on the breadboard are satisfying, the real circuit construction can start. All the components are installed on a stripboard and the soldering begins with a lot of care. The soldered circuit is shown on **figure IV.16**.

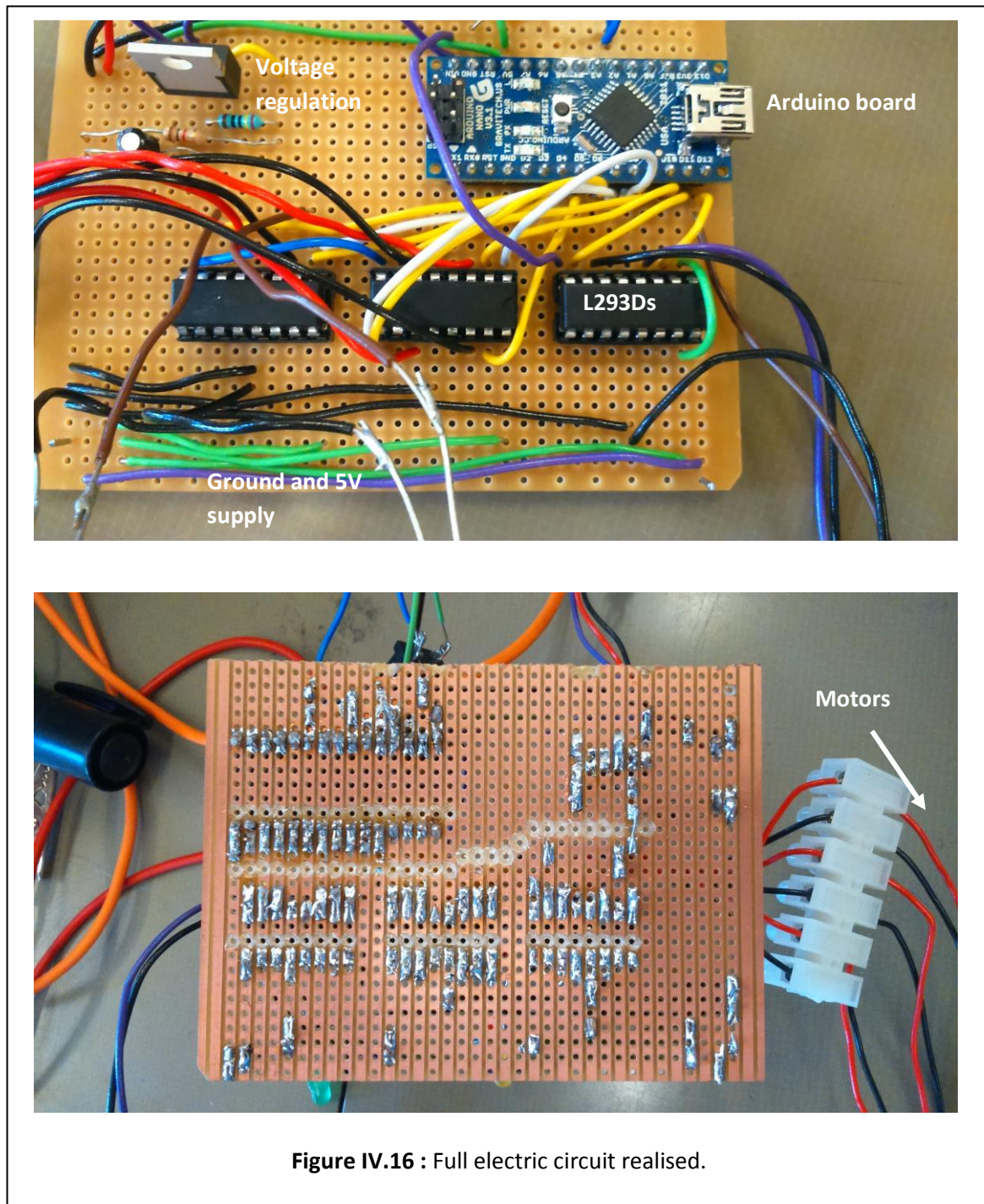

Figure IV.16 : Full electric circuit realised.

The circuit board may look messy at first glance, but a special care has been given to the access to different components, as well as a colour code useful during the realisation but designed mostly for future persons trying to use the circuit board.

V - Results and Discussion

V.A - Prototype results

V.A.1. The prototype's state

The **figure V.1** shows a picture of the different prototype obtained at the dissertation deadline.

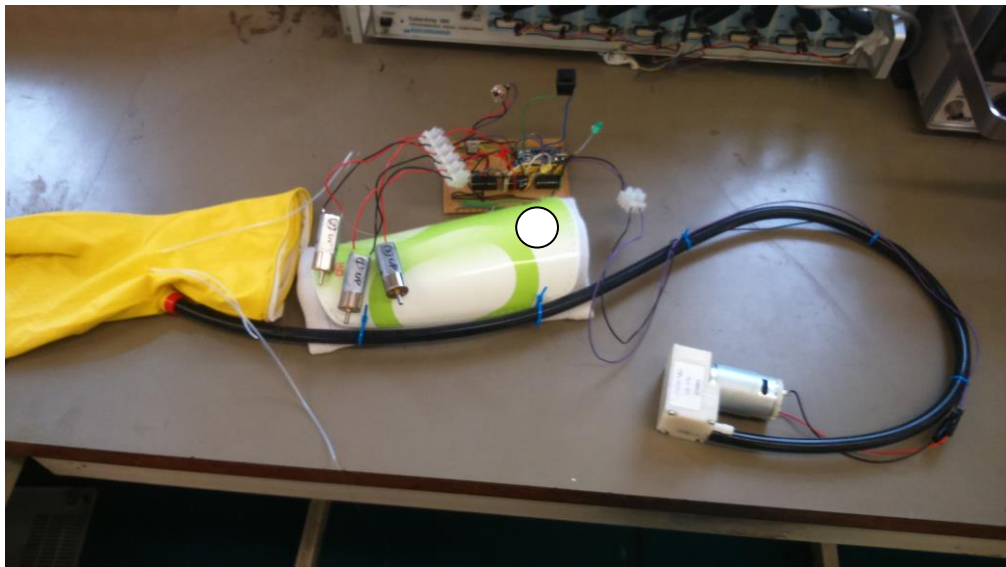

Figure V.1 : Prototype at the 13th of August.

As explained earlier in **part III.4.**, the support for the motors and the control card could not be build on time, only the sleeve and the base of support have been constructed. But on the bright side, the control card is fully operational, which allows to test the vacuum of the glove and to try a few hand flexions.

V.A.2.Vacuum Test

The **figure V.2** shows the vacuum test we carried o the prototype.



Figure V.2 : Vacuum test of the prototype

Despite the poor sealing between the two gloves, the vacuum provided was quite satisfying, the suction cups were holding well in place and the vacuum stayed stable. A little downside is that the tubing must be held in this precise position, or the aspiration

directly sucks the inner layer and closes the vacuum access. Hopefully, the plastic rings on the side of the support sleeve help keep the tube in place during the test.

V.A.3. Flexion test

The motors do not have a support but a test is still possible by holding one motor in place on the forearm, the **figure V.3** shows the mechanism before starting the test, and when the maximal flexion of the middle finger was reached.

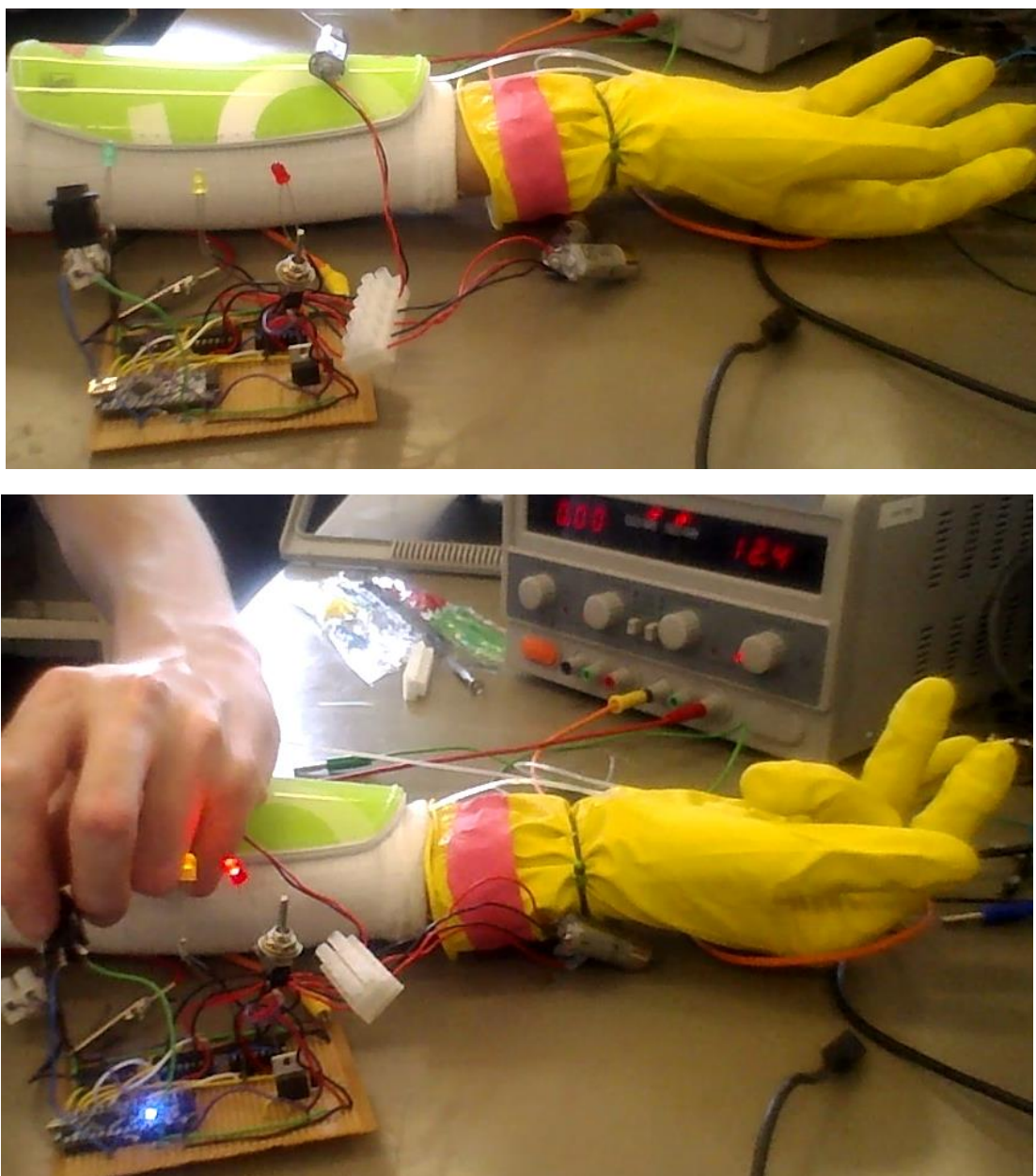

Figure V.3 : Exercise test of the prototype

As shown on the second picture, the resulting range of motion was very satisfying, as the finger was almost completely flexed. It seems the distal phalange cannot reach a better flexion angle than what is shown, probably because of the positions of the suction cups on the middle and distal phalange.

There is also a slight problem with the actuation, the motors are way too slow. The movement shown on **figure V.3** took 7 to 8 seconds to be achieved, at which must be added the time for the motors to go back in position.

Unfortunately, these tests are the only one we carried at this date, and no proper technical evaluation, of the grasping force generated for example, or better cinematic measurements. A comparison with the other existing devices would be interesting if more concrete results were available, but this will probably be for a next study, when more tests will have been carried.

V.B - Discussion

V.B.1. Apparent weaknesses

The sealing issues between the two gloves were already highlighted in **part III.4** , and are due to a lack of preparation for this step of the construction. It was not considered an obstacle and it proved to be less evident than expected. The problem is not conceptual and only depends on the method used, so a solution can be found to this problem in the future, maybe with the adjunction of an air-proof sleeve, or just by making the base of the gloves more rigid to allow the tape or glue used to stay in place.

The motor choice was proven to be deficient as well. During the design phase, the fear of the resistance of the hand to flexion was probably too much emphasized, and the focus on the traction force completely eclipsed speed considerations. In practice, the traction force needed to operate the glove is probably closer to 40-50 N, which means the motors could be changed for 3 times faster ones. In a way, the fact that the movements are slow during the development phase is not much of a problem, especially while the device is not completely safe, even if a faster motor can also see its speed reduced by the program. Again, the weakness is not a problem of concept, which is reassuring for the device viability.

V.B.2. Encouraging prospects

Despite the difficulty to carry on this project to a satisfying end in such a short amount of time, we achieved several goals of our project : the Rehabilitation Glove is flexible, the hand range of motion is practically not affected when the vacuum is turned off, it is very lightweight thanks to the choice of cable-driven technology, it easy to don and doff with one sane hand, and finally it brings assistance to almost the entire flexion of the fingers.

A battery dimensioning has to be carried, because of the 0,6A current that goes though the whole system when the motors are working, but it is still in the range of existing compact batteries which would allow full liberty to carry the device.

Plus, the whole design of the prototype has been made so that every part of it is easily reusable and improvable in further projects, which only suggests future improvements of the Rehabilitation Glove.

CONCLUSION

The Rehabilitation Glove carries a new concept by using vacuum to rigidify a glove directly, compared to other "soft" exoskeletons. Its technology may not be a revolutionary concept, but very few robotic devices in service today are dedicated to the hand rehabilitation, and the features that offer such a kind of device are very interesting for the development of home rehabilitation for the patients, and the substantial relief it can offer to the therapists in rehabilitation centres is non negligible.

There is still a lot of room for improvement, but there is no doubt this rehabilitation device will continue to be developed, probably by other students of the Biomedical Engineering Department of the Strathclyde University, and if a good inter-communication between the different projects is installed, the vacuum glove concept may realistically become a part of the modern rehabilitation techniques.

REFERENCES

By order of appearance :

- [Friden et al, 2003] Friden N., Lieber R.L., "Spastic Muscle Cells are Shorter and Stiffer than Normal Cells", *Muscle Nerve*, no.26, pp.157-164, 2003.
- [Gemperline et al, 1995] Gemperline J.J., Allen S. , Walk D., Rymer W.Z., "Characteristics of motor unit discharge in subjects with hemiparesis", *Muscle & nerve*, no.18, pp.1101-14, 1995.
- [Van der Lee et al, 1999] Van der Lee J.H., Wagenaar R.C., Lankhorst G.J., Vogelaar T.W., Deville W.L., Bouter L.M., "Forced Use of the Upper Extremity in Chronic Stroke Patients, Results from a Single-Blind Randomized Clinical Trial", *Stroke*, pp.2369-2375, November 1999.
- [Lin et al, 1999] Lin F.-H., Sabbahi M., "Correlation of Spasticity With Hyperactive Stretch Reflexes and Motor Dysfunction in Hemiplegia", *Archives of Physical Medicine and Rehabilitation*, no.80, pp.526-530, May 1999.
- [Cicinellia et al, 1997] Cicinellia P., Traversaa R., Rossin P.M., "Post-stroke reorganization of brain motor output to the hand: a 2–4 month follow-up with focal magnetic transcranial stimulation", *Electroencephalography and clinical Neurophysiology*, no.405, pp.438- 450, 1997.
- [Dobkin et al, 2004] Dobkin B.H., "Strategies for stroke rehabilitation", *THE LANCET Neurology*, no.3, pp.528-536, 2004.
- [Molier et al, 2012] Molier B.I., "Influence of augmented feedback on learning upper extremity tasks after stroke", 2012.
- [Biitefisch et al, 1995] Biitefisch C., Hummelsheim H., Denzler P., Mauritz K.H, "Repetitive training of isolated movements improves the outcome of motor rehabilitation of the centrally paretic hand" , *Journal of the Neurological Sciences*, no.130, pp.59-68, 1995.

- [Lieperta et al, 1998] Lieperta J., Miltnerb W.H.R., Bauderb H., Sommerb M., Dettmersa C., Taubc E., Weiller C., "Motor cortex plasticity during constraint-induce movement therapy in stroke patients", *Neuroscience Letters*, no.250, pp.5-8, 1998.
- [Carroll, 1965] Carroll D., "A Quantitative Test for Upper Extremity Function", *Journal of Chronic Diseases*, no.18, pp.479-491, 1965.
- [Van der Lee et al, 2001] Van der Lee J.H., De Groot V., Beckerman H., Wagenaar R.C., Lankhorst G.J., Bouter L.M., "The intra- and interrater reliability of the action research arm test: a practical test of upper extremity function in patients with stroke", *Archives of Physical Medicine and Rehabilitation*, no.82, pp.14-19, January 2001.
- [Lyle et al, 1981] Lyle R.C., "A performance test for assessment of upper limb function in physical rehabilitation treatment and research", *International Journal of Rehabilitation Research*, no.4, pp.483-492, 1981.
- [Busse et al, 2004] Busse M.E., Pearson O.R., Van Deursen R., Wiles C.M., "Quantified measurement of activity provides insight in to motor function and recovery in neurological disease", *Journal of Neurology, Neurosurgery and Psychiatry*, no.75, pp.884-888, 2004.
- [Oujamaa et al, 2009] Oujamaa L., Relave I., Froger J., Mottet D., Pelissier J.-Y., "Rehabilitation of arm function after stroke. Literature review", *Annals of Physical and Rehabilitation Medicine*, no.52, pp.269–293, 2009.
- [Wang et al, 2011] Wang Q., Zhao J., Zhu Q., Li J., Meng P., " Comparison of conventional therapy, intensive therapy and modified Constraint-Induced Movement therapy to improve upper extremity function after stroke.", *Journal of Rehabilitation Medicine*, no.43, pp.619-625, 2011.

- [Winstein et al, 2004] Winstein C.J., Rose D.K., Tan S.M., Lewthwaite, R., Chui, H.C., Azen, S.P., "A Randomized Controlled Comparison of Upper-Extremity Rehabilitation Strategies in Acute Stroke : A Pilot Study of Immediate and Long-Term Outcomes", *Archives of Physical Medicine and Rehabilitation*, no.85, pp.620-628, April 2004.
- [Platz et al, 2005] Platz T., Eickhof C., van Kaick S., Engel U., Pinkowski C., Kalok S., Pause M., "Impairment-oriented training or Bobath therapy for severe arm paresis after stroke: a single-blind, multicentre randomized controlled trial.", *Clinical Rehabilitation*, no.7, pp.714-724, 2005.
- [Graham et al, 2009] Graham J.V, Eustace C., Brock K., Swain E., Irwin-Carruthers S., "The Bobath Concept in Contemporary Clinical Practice", *Top Stroke Rehabilitation*, no.16, pp.57-68, 2009.
- [Platz et al, 2005] Platz T., Eickhof C., van Kaick S., Engel U., Pinkowski C., "Impairment-oriented training or Bobath therapy for severe arm paresis after stroke : a single-blind, multicentre randomised controlled trial", *Clinical Rehabilitation*, no.19, pp.714-724, 2005.
- [Ploughman et al, 2004] Ploughman M., Corbett D., "Can Forced-Use Therapy Be Clinically Applied After Stroke ? An Exploratory Randomized Controlled Trial", *Archives of Physical Medicine and Rehabilitation*, no.85, pp.1417-1423, 2004.
- [Page et al, 2004] Page S.J., Sisto S., Levine P., McGrath R.E., "Efficacy of modified constraint-induced movement therapy in chronic stroke: a single-blinded randomized controlled trial.", *Archives of Physical Medicine and Rehabilitation*, no.85, pp.48-18, 2004.
- [Chen et al, 2005] Chen J., Liang C., Shaw F., "Facilitation of sensory and motor recovery by thermal intervention for hemiplegic upper limb in acute stroke patients.", *Stroke*, no.36, pp.2665–2669, 2005.

- [Dohle et al, 2008] Dohle C., Püllen J., Nakaten A., Küst J., Rietz C., Karbe H., "Mirror Therapy Promotes Recovery From Severe Hemiparesis: A Randomized Controlled Trial", *Neurorehabilitation and Neural Repair OnlineFirst*, published on December 12, 2008.
- [Yavuzer et al, 2008] Yavuzer G., Selles R., Sezer N., Sütbeyaz S., Bussmann J.B., Köseoğlu F., Atay M., Stam H., "Mirror therapy improves hand function in subacute stroke: a randomized controlled trial", *Archives of Physical Medicine and Rehabilitation*, no.89, pp.393- 398, 2008.
- [Bouzit et al, 2002] Bouzit M., Popescu G., Burdea G., Boian R., "The rutgers master IInd force feedback glove", *Proceedings of IEEE VR Haptics Symposium*, March 2002.
- [Casadio et al, 2009] Casadio M., Giannoni P., Morasso P., Sanguineti V., "A proof of concept study for the integration of robot therapy with physiotherapy in the treatment of stroke patients", *Clinical Rehabilitation*, no.23, pp.217-228, 2009.
- [Bonan et al, 2004] Bonan I.V., Yelnik A.P., Colle F.M., Michaud C., Normand E., Panigot B., Roth P., Guichard J.P., Vicaut E., "Reliance on Visual Information After Stroke. Part II: Effectiveness of a Balance Rehabilitation Program With Visual Cue Deprivation After Stroke: A Randomized Controlled Trial", *Archives of Physical Medicine and Rehabilitation*, no.85, pp.274-278, 2004.
- [Maclean et al, 2000] Maclean N., Pound P., Wolfe C., Rudd A., "Qualitative analysis of stroke patients' motivation for rehabilitation", *BMJ*, no.321, pp.1051-1054, 2000.
- [Lenzi et al, 2008] Lenzi G.L., Altieri M., Maestrini I., "Post-stroke depression", *Journal Neurologique*, no.10, pp.837-840, 2008.
- [Lump et al, 2002] Lum P.S., Burgar C.G., Shor P.C., Majmundar M., Van der Loos M., "Robot-Assisted Movement Training Compared with Conventional Therapy Techniques for the Rehabilitation of Upper-Limb Motor

- Function After Stroke", *Archives of Physical Medicine and Rehabilitation*, no.83, pp.952-959, 2002.
- [Masiero et al, 2007] Masiero S., Celia A., Rosati G., Armani M., " Robotic-assisted rehabilitation of the upper limb after acute stroke", *Archives of Physical Medicine and Rehabilitation*, no.88, pp.142–149, 2007.
- [Casadio et al, 2006] Casadio M., Morasso P., Sanguineti V., Giannoni P., "Impedance-controlled, minimally-assistive robotic training of severely impaired hemiparetic patients", *Proceedings of BioRob 2006 (the First IEEE/RAS-EMBS International Conference on Biomedical Robotics and Biomechatronics)*, pp.20–22, February 2006.
- [Hesse et al, 2003] Hesse S., Schulte-Tigges G., Konrad M., Bardeleben A., Werner C., "Robot-Assisted Arm Trainer for the Passive and Active Practice of Bilateral Forearm and Wrist Movements in Hemiparetic Subjects", *Archives of Physical Medicine and Rehabilitation*, no.84, pp.915-920, June 2003.
- [Lazzaro et al, 1998] Lazzaro V. D., Restuccia D., Oliviero A., Profice P., Ferrara L., Insola A., Mazzone P., Tonal P., Rothwell J.C., "Effects of voluntary contraction on descending volleys evoked by transcranial stimulation in conscious humans", *The Journal of physiology*, no.508(2), pp.625-633, 1998.
- [Casadio et al, 2006] Casadio M., Morasso P., Sanguineti V., Arrichiello V., "Braccio di Ferro: a new haptic workstation for neuromotor rehabilitation", *Technology and Health Care*, no.13, pp.1–20, 2006.
- [HealthPact, 2014] HealthPact Health Policy Advisory Committee on Technology, "Technology Brief : Intensive upper limb stroke rehabilitation", November 2014.
- [Iacoboni et al, 2009] Iacoboni M., Woods R., Brass M., Bekkering H., Mazziotta J., Rizzolatti G., "Cortical mechanisms of human imitation", *Science*, no.286, pp.2526–2528, 2009.

- [Flash et al, 1985] Flash T., Hogan N., "The coordination of arm movements : an experimentally confirmed mathematical model.", *Journal of Neurosciences*, vol.5, pp.1688–1703, 1985.
- [Kahn et al, 2006] Kahn L.E., Lum P.S., Rymer W.Z., "Robot-assisted movement training for the stroke-impaired arm : does it matter what the robot does ?", *Journal of Rehabilitation Research and Development*, vol.43, pp.619–630, 2006.
- [Rossi et al, 2007] Rossi A., Rosati G., "Rehabilitation robotics in padua, italy", *Rehabilitation Robotics, 2007. ICORR 2007. IEEE 10th International Conference on*, pp. 323–327, 2007.
- [Mulas et al, 2005] Mulas M., Folgheraiter M., Gini G., "An EMG-controlled Exoskeleton for Hand Rehabilitation", *Proceedings 2005 IEEE International Conference on Rehabilitation Robotics*, pp. 31-374, Chicago, USA, July 2005.
- [Perry et al, 2007] Perry J.C., Rosen J., Burns S., "Upper-Limb Powered Exoskeleton Design", *IEEE/ASME Transactions on Mechatronic*, vol.12, no.4, pp.408-418, 2007.
- [Jarassé et al, 2010] Jarassé N., French thesis : "Contributions à l'exploitation d'exosquelettes actifs pour la rééducation neuromotrice", *Archives ouvertes.fr*, 2010.
- [Reinkinsmeyer et al, 2000] Reinkensmeyer D.J., Kahn L.E., Averbuch M., McKenna-Cole A., Schmit B.D., Rymer W.Z., "Understanding and treating arm movement impairment after chronic brain injury : Progress with the ARM guide", *Journal of Rehabilitation Research and Development*, no.6, pp.653-662, 2000.

- [Reikensmeyer et al, 2009] Reikensmeyer D.J., Schmit B.D., Rymer W.Z., "Assessment of active and passive restraint during guided reaching after chronic brain injury", *Annals of Biomedical Engineering*, no.27, pp.805-814, 2009.
- [Kwakkel et al, 2007] Kwakkel G., Kollen B.J., Krebs H.I., "Effects of Robot-Assisted Therapy on Upper Limb Recovery After Stroke: A Systematic Review", *Neurorehabilitation and Neural Repair*,no.22, 2007.
- [Folgheraiter et al, 2000] Folgheraiter M., Gini G., "Blackfingers : an artificial hand that copies human hand in structure, size, and function", *Proceedings of IEEE Humanoids 2000*, Cambridge, September 2000.
- [Gopura et al, 2011] Gopura R.A.R.C., Kiguchi K., Bandara D.S.V. "A brief review on upper extremity robotic exoskeleton systems", *Proceedings International conference on industrial and information systems*, pp. 346-351, Sri Lanka, 2011.
- [Xu et al, 2013] Xu Z., Kumar V., Todorov E., "A Low-cost and Modular, 20-DOF Anthropomorphic Robotic Hand : Design, Actuation and Modeling", *IEEE-RAS International Conference on Humanoid Robots*, 2013.
- [Kexin et al, 2009] Kexin X., Huang J., Xu Q., Wang Y. "Design of a wearable rehabilitation robotic hand actuated by pneumatic artificial muscles", *7th Asian Control Conference*, pp.740-744, Hong Kong, 2009.

APPENDIXES

APPENDIX I - REHABILITATION EXERCISES

Repeat these exercises times for times a day.

These exercises will strengthen the muscles of your fingers, hand and forearm.

Finger Hook

Make a hook with your fingers as you press into the putty.



Full Grip

Squeeze your fingers into the putty like your are making a fist.



Finger Extension

Loop the putty over the end of the finger while it is bent. Try to straighten your finger.

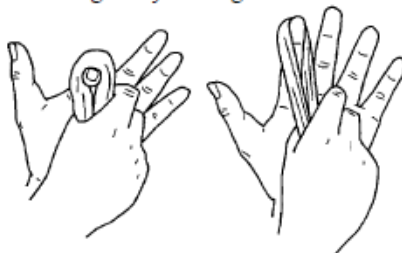

Finger Spread

Spread the putty like a pancake over your fingers and thumb. Try to spread them apart.



Finger Scissor

Place a 1 inch thick piece of putty between each pair of fingers and squeeze together.

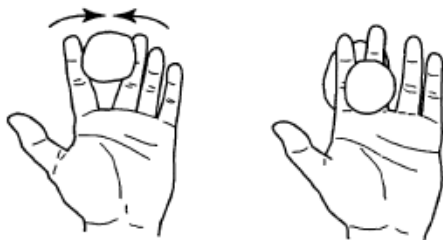

Finger Pinch

Pinch the putty between each finger and the thumb.



Scissor Spread

Place putty around two fingers at a time and try to spread them apart.

**Thumb Extension**

Loop the putty at the end of your thumb while it is bent. Try to straighten your thumb by pulling it upward.

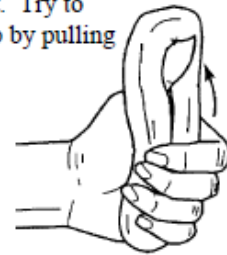
**Thumb Press**

Push your thumb into the putty as you move the thumb toward your small finger.

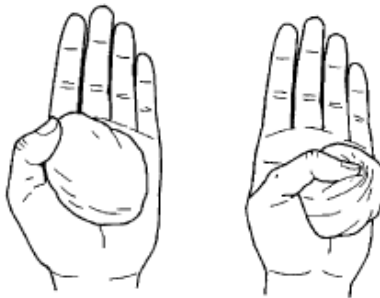
**Thumb Adduction**

Press the putty with your thumb against the side of your index finger. Keep your fingers and thumb straight.

**Thumb Pinch Strengthening**

Squeeze the putty between your thumb and side of the index finger.

**Three Jaw Chuck Pinch**

Pull the putty using your thumb, index and middle finger.



APPENDIX II - Specs Sheets

Motor Specs

GM21 Mini Metal Gear Motor Sealed Case - Long Motor

Centered 3mm output shaft

Ratio: 360:1

Dimensions: 49.3 x 15.5 x 15.5mm

Weight: 26.3g

CCW rotation

0.59V @ startup



1-866-276-2687

www.solarbotics.com

Test Voltage (V)	Unloaded RPM	Unloaded Current (mA)	Stall Current (mA)	Stall Torque	
				(gm ² cm)	(oz ² in)
1.5	5	34	182	1588	21.8
3	11	38	360	3570	49.6
4.5	17	40	532	5880	81.7
6	23	42	692	7434	103.2

Suction Cups



Material in Motion

102.006.013.*
15-Jun-2015 18:54:21

http://www.fipa.com/en_GB/product/212513-8mm

102.006.013.*

Bestseller

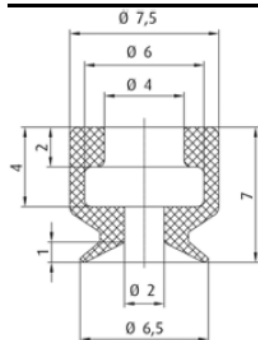

Suitable spring levelers (Snap-In)	
Item no.	Hub[mm]
50.330	10

Suitable fittings	
Item no.	Connection
270.010	M5-male
270.005	M5-female
270.009	G1/8-male
270.007	G1/8-female

Technical data

Item no.	102.006.013.1	102.006.013.2/17	102.006.013.2AS	102.006.013.5
Material / Colour	NBR (sw)	SI (tr)	SI-AS (sw)	PU (bl)
[mm]	1	1	1	1

APPENDIX III - CIRCUIT

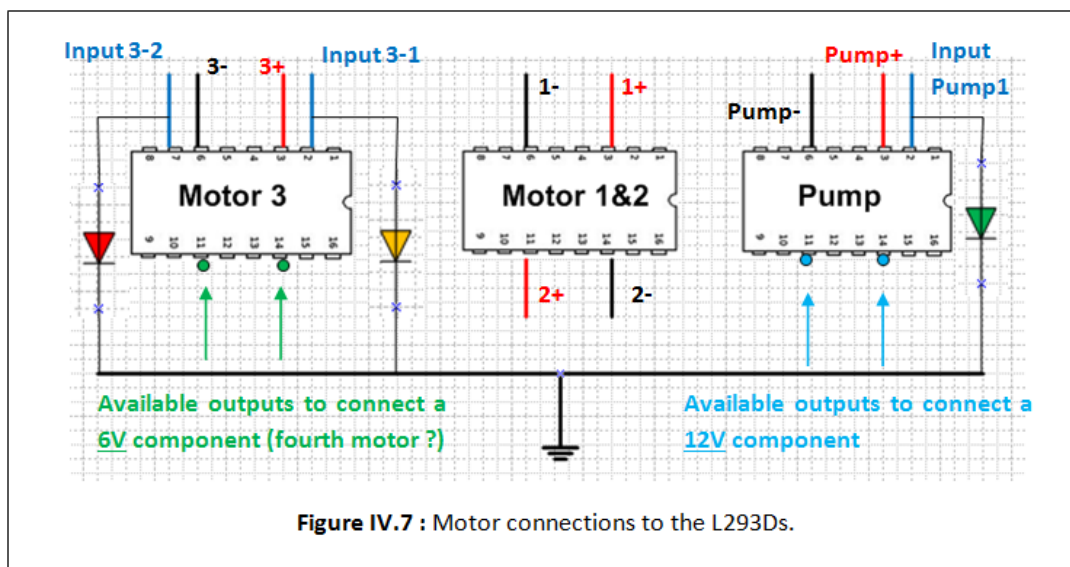
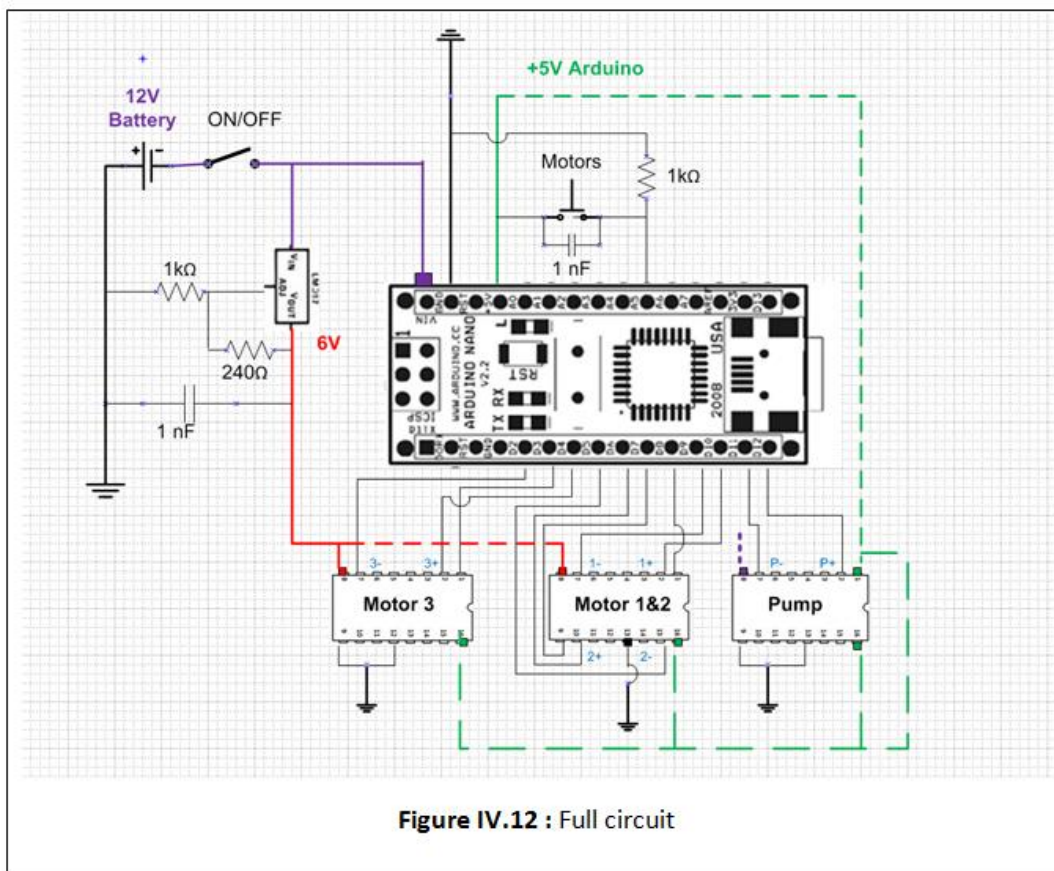

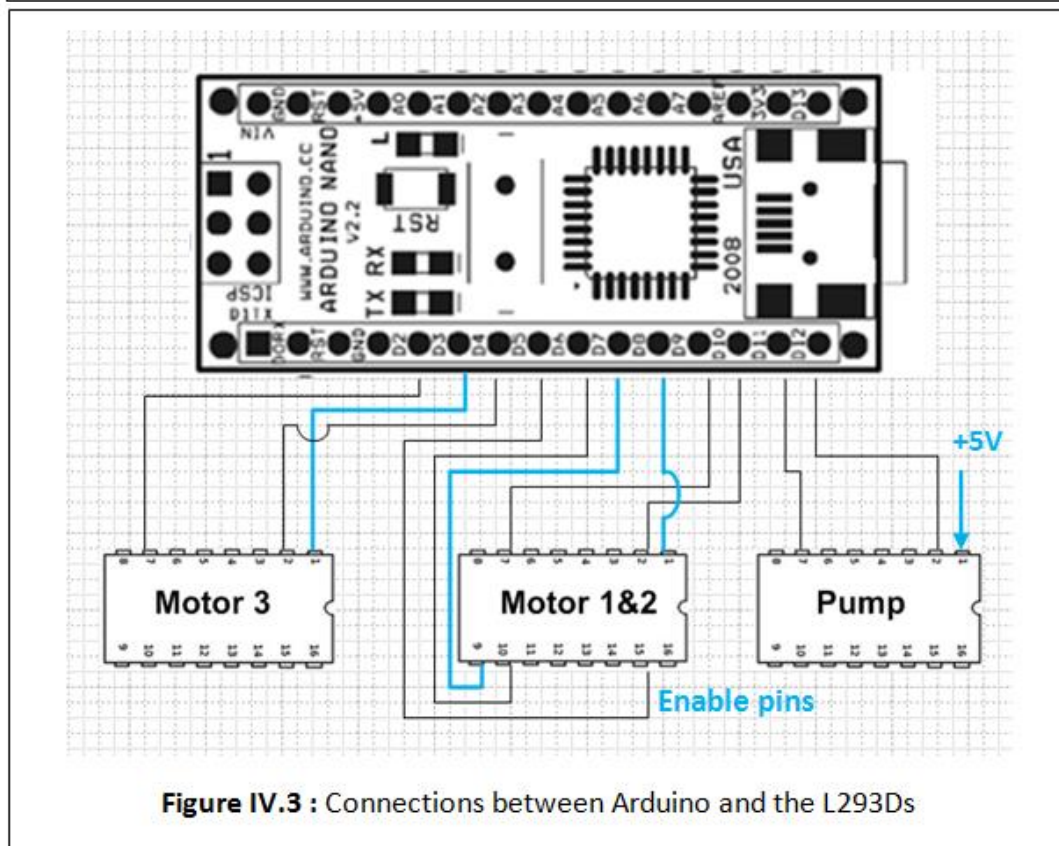
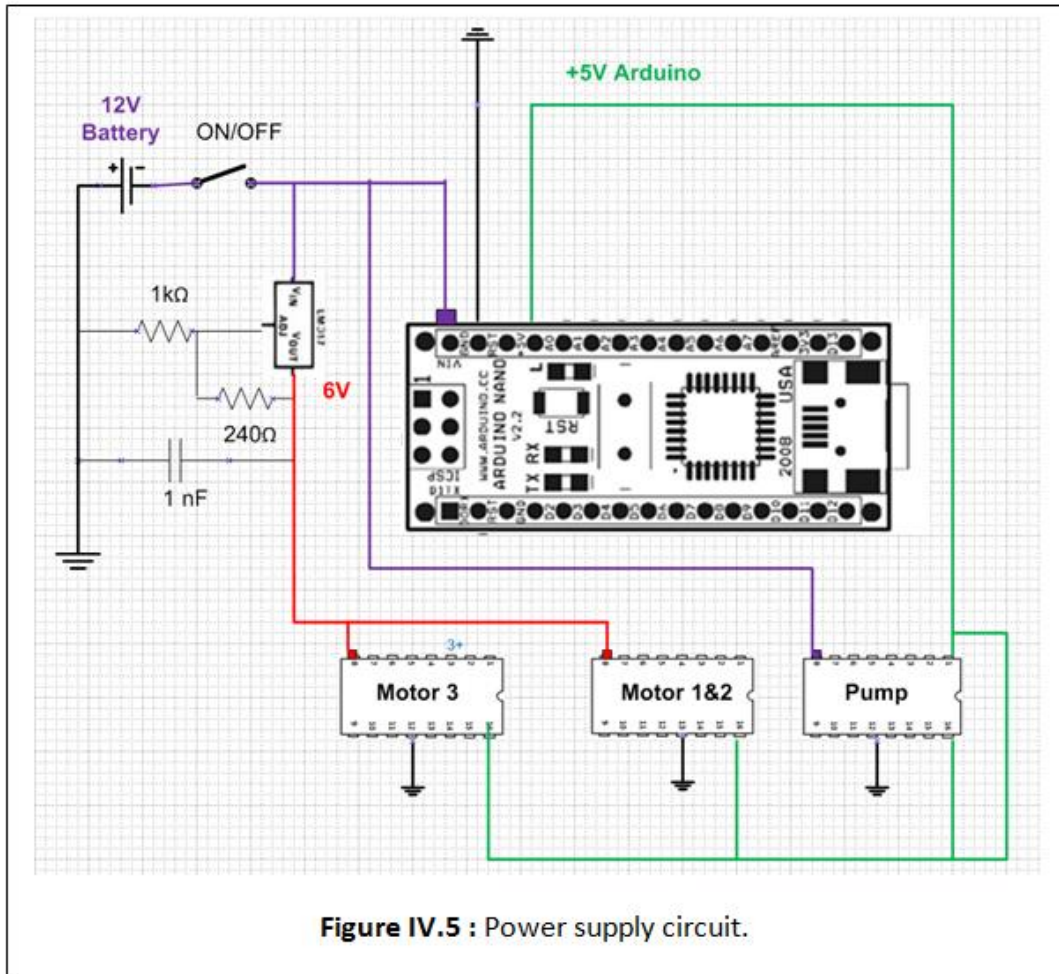

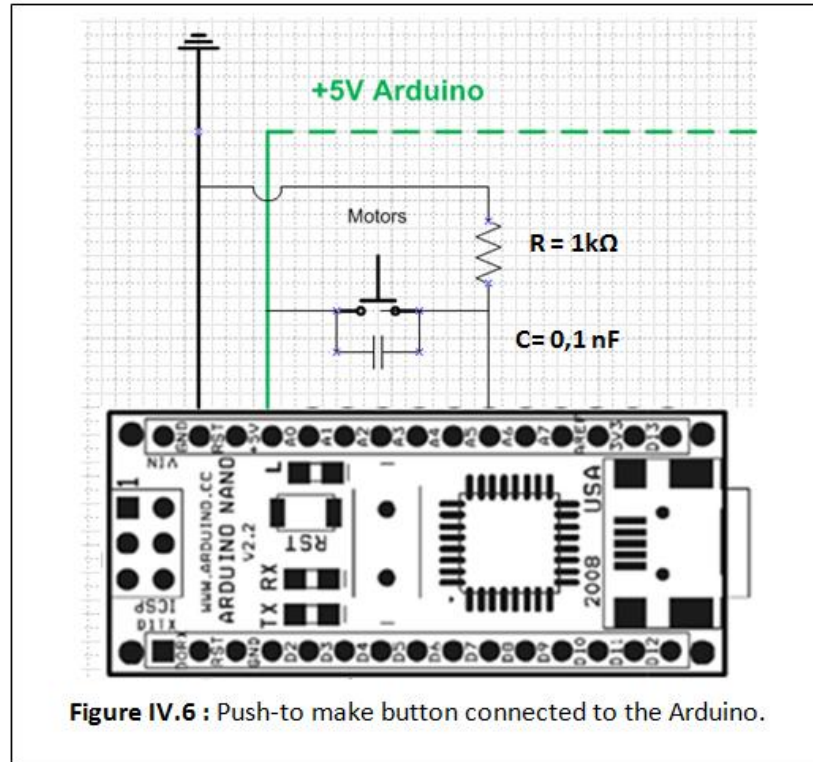

Figure IV.6 : Push-to make button connected to the Arduino.

APPENDIX IV - PROGRAM

```
// Give the pins names to ease the comprehension of the program

const int Pump1 = 12;
const int Pump2 = 11;

const int EN1 = 8; //PWM
const int M11 = 10;
const int M12 = 9;

const int EN2 = 7; //PWM
const int M21 = 6;
const int M22 = 5;

const int EN3 = 3; //PWM
const int M31 = 4;
const int M32 = 2;

const int MotorButton = A2;

/*We create a serie of constants and funtions to read
 * the change of state of the analog push-to-make button
 */

const boolean Pressed = true;
const boolean Free = false;

const byte Motor_No_Event =0;
const byte Motor_Button_Pressed = 1;
const byte Motor_Button_Free = 2;

int timepress;
int timefree;

boolean MotorState = Free;

boolean ReadMotorState(){
  boolean result = Free;

  if(analogRead(MotorButton)> 512)
```

```
    if (analogRead(MotorButton) > 512)
    { result = Pressed;}

    return result;
}

byte ReadMotorEvent() {

    byte Event;
    boolean NewState = ReadMotorState();

    if (NewState == MotorState)
        Event = Motor_No_Event;

    if (NewState == Pressed && MotorState == Free)
        Event = Motor_Button_Pressed;

    if (NewState == Free && MotorState == Pressed)
        Event = Motor_Button_Free;

    MotorState = NewState;
    return Event;

}

// we write down all our independant functions :

/* For the vacuum ON and OFF are passing current through the motor
 * or stopping passing current
 */

void VacuumON() {

    digitalWrite(Pump1, HIGH);
    digitalWrite(Pump2, LOW);
}

void VacuumOFF() {

    digitalWrite(Pump1, LOW);
    digitalWrite(Pump2, LOW);
}
```

```
/*For the motors, ON is passing current in the right way
 *
 * HOLD is putting current on both side to induce magnetic brake
 *
 * OFF is stopping current (free-wheel)
 *
 * We could imagine a further function (REVERSE) where we would
 * invert the current and make the motor turn the other way
 */

void MotorON() {

    digitalWrite (M11, HIGH);
    digitalWrite (M21, HIGH);
    digitalWrite (M31, HIGH);
    digitalWrite (M12, LOW);
    digitalWrite (M22, LOW);
    digitalWrite (M32, LOW);

}

void MotorHOLD() {

    digitalWrite (M11, HIGH);
    digitalWrite (M21, HIGH);
    digitalWrite (M31, HIGH);
    digitalWrite (M12, HIGH);
    digitalWrite (M22, HIGH);
    digitalWrite (M32, HIGH);

}

void MotorMINUS() {

    digitalWrite (M11, LOW);
    digitalWrite (M21, LOW);
    digitalWrite (M31, LOW);
    digitalWrite (M12, HIGH);
    digitalWrite (M22, HIGH);
    digitalWrite (M32, HIGH);

}
```

```
void MotorOFF() {

    digitalWrite (M11, LOW);
    digitalWrite (M21, LOW);
    digitalWrite (M31, LOW);
    digitalWrite (M12, LOW);
    digitalWrite (M22, LOW);
    digitalWrite (M32, LOW);
}

//Initiation function :

void setup() {

    // declare INPUTS and OUTPUTS

    pinMode (EN1, OUTPUT);
    pinMode (Pump1, OUTPUT);
    pinMode (Pump2, OUTPUT);
    pinMode (EN2, OUTPUT);
    pinMode (M11, OUTPUT);
    pinMode (M12, OUTPUT);
    pinMode (M21, OUTPUT);
    pinMode (M22, OUTPUT);
    pinMode (EN3, OUTPUT);
    pinMode (M31, OUTPUT);
    pinMode (M32, OUTPUT);

} //end of initiation function

void loop() {

    /*We activate all the motors at maximum speed (PWM allows to control the
    * output between 0 and 255. This allows further functions for future development
    */

    analogWrite (EN1, 250);
    analogWrite (EN2, 250);
    analogWrite (EN3, 250);
```

```
byte Event = ReadMotorEvent();

VacuumON();

//When the motor button is pressed

if(Event == Motor_Button_Pressed) {
    timepress = millis();
    MotorON();
}

//when we stop pressing the button

if(Event == Motor_Button_Free) {
    timefree=millis();
    MotorHOLD();
    delay(3000);
    MotorMINUS();
    delay(timefree-timepress);
    timepress = 0;
    timefree=0;
    MotorOFF();
}
}
```